



US00D560558S

(12) **United States Design Patent**  
**Hughes et al.**

(10) **Patent No.:** **US D560,558 S**  
(45) **Date of Patent:** **\*\* Jan. 29, 2008**

(54) **UTILITY SERVICE TRAILER**

(75) Inventors: **James T. Hughes**, Fredericktown, OH (US); **Thomas J. Boyer**, Wooster, OH (US)

(73) Assignee: **Stahl/Scott Fetzer Company**, Wooster, OH (US)

(\*\*) Term: **14 Years**

(21) Appl. No.: **29/246,883**

(22) Filed: **May 18, 2006**

(51) **LOC (8) Cl.** ..... **12-10**

(52) **U.S. Cl.** ..... **D12/102**

(58) **Field of Classification Search** ..... D12/100-106,  
D12/180.2, 181.3, 204, 656

See application file for complete search history.

(56) **References Cited**

**U.S. PATENT DOCUMENTS**

- D134,573 S \* 12/1942 Glascock, Jr. et al. .... D12/102
- D168,535 S \* 1/1953 Couse ..... D12/102
- D168,536 S \* 1/1953 Couse ..... D12/102
- D172,713 S \* 7/1954 Owen ..... D12/105
- 3,734,525 A \* 5/1973 Rimbey ..... 280/30
- D243,596 S \* 3/1977 Ksenych ..... D12/102
- D256,114 S \* 7/1980 Bell, Jr. .... D12/102
- D271,093 S \* 10/1983 Triggs ..... D12/102
- D342,930 S 1/1994 Lewellen et al.
- D343,146 S \* 1/1994 Premo ..... D12/103
- D351,816 S 10/1994 Lewellen et al.
- D351,817 S 10/1994 Lewellen et al.
- D382,834 S 8/1997 Perlman et al.
- D385,224 S 10/1997 Aros et al.
- D388,756 S 1/1998 Perlman et al.
- D408,334 S \* 4/1999 Fortunato ..... D12/102
- D414,137 S 9/1999 Aros et al.

- D414,138 S 9/1999 McKinney et al.
- D414,139 S 9/1999 Aros et al.
- D445,387 S 7/2001 Waldeck
- D458,190 S \* 6/2002 LeDonne ..... D12/102
- D464,593 S \* 10/2002 Register ..... D12/102
- 6,955,385 B1 10/2005 Boyer
- 6,976,290 B2 12/2005 Boyer et al.
- D520,425 S 5/2006 Boyer et al.
- D520,926 S 5/2006 Boyer et al.
- D521,433 S 5/2006 Boyer et al.

**FOREIGN PATENT DOCUMENTS**

- WO 2005/102774 11/2005
- WO 2005/103427 11/2005

\* cited by examiner

*Primary Examiner*—Caron D. Veynar

*Assistant Examiner*—Abraham Bahta

(74) *Attorney, Agent, or Firm*—Pearne & Gordon LLP

(57) **CLAIM**

The ornamental design for a utility service trailer, as shown and described.

**DESCRIPTION**

FIG. 1 is a perspective view of our new design for a utility service trailer;

FIG. 2 is a left side elevational view thereof;

FIG. 3 is a right side elevational view of FIG. 1;

FIG. 4 is a top plan view of FIG. 1;

FIG. 5 is a bottom plan view of FIG. 1;

FIG. 6 is a front elevational view of FIG. 1; and,

FIG. 7 is a back elevational view of FIG. 1.

The broken lines shown are for illustrative purposes only and form no part of the claimed design.

**1 Claim, 6 Drawing Sheets**

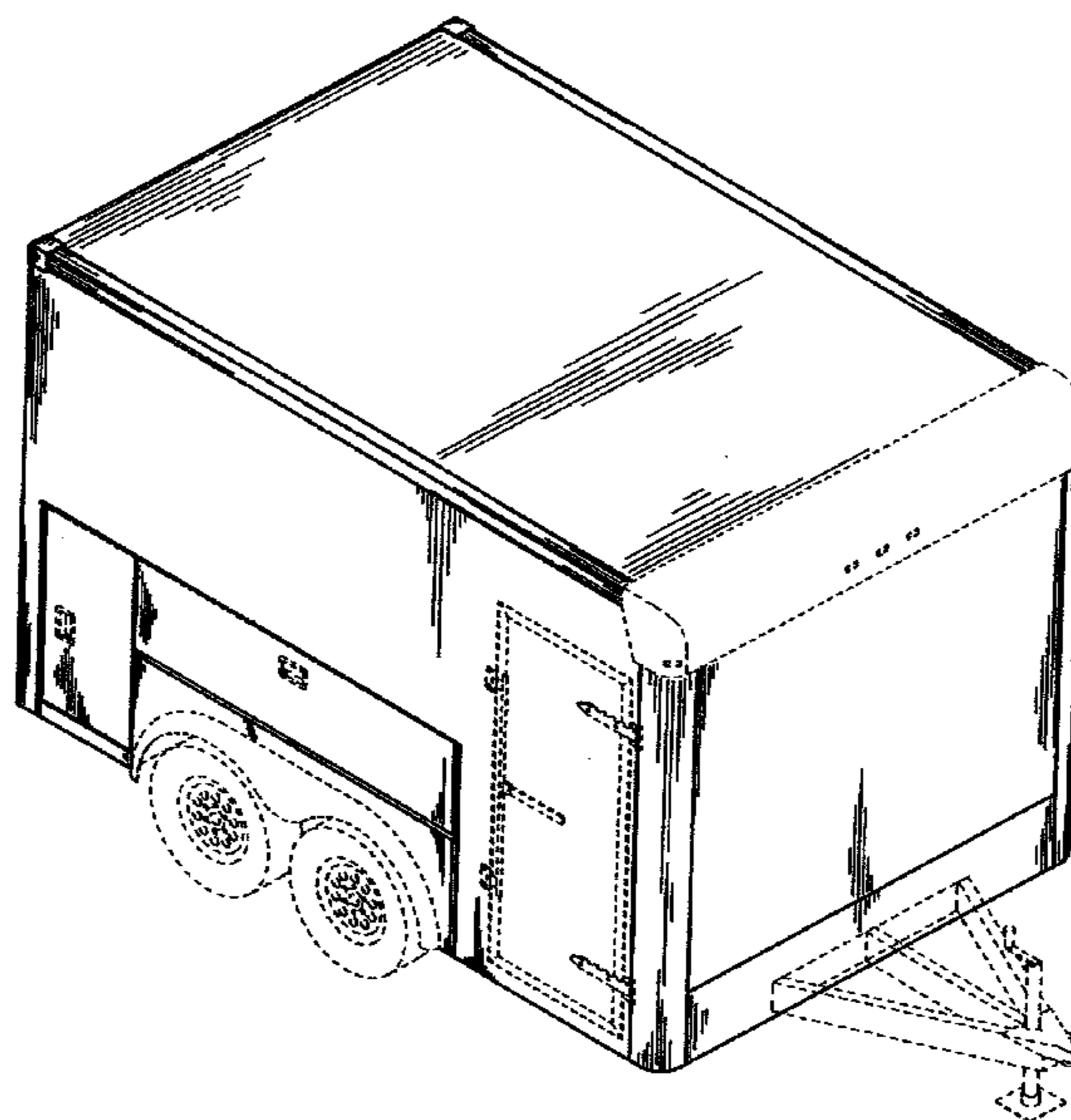

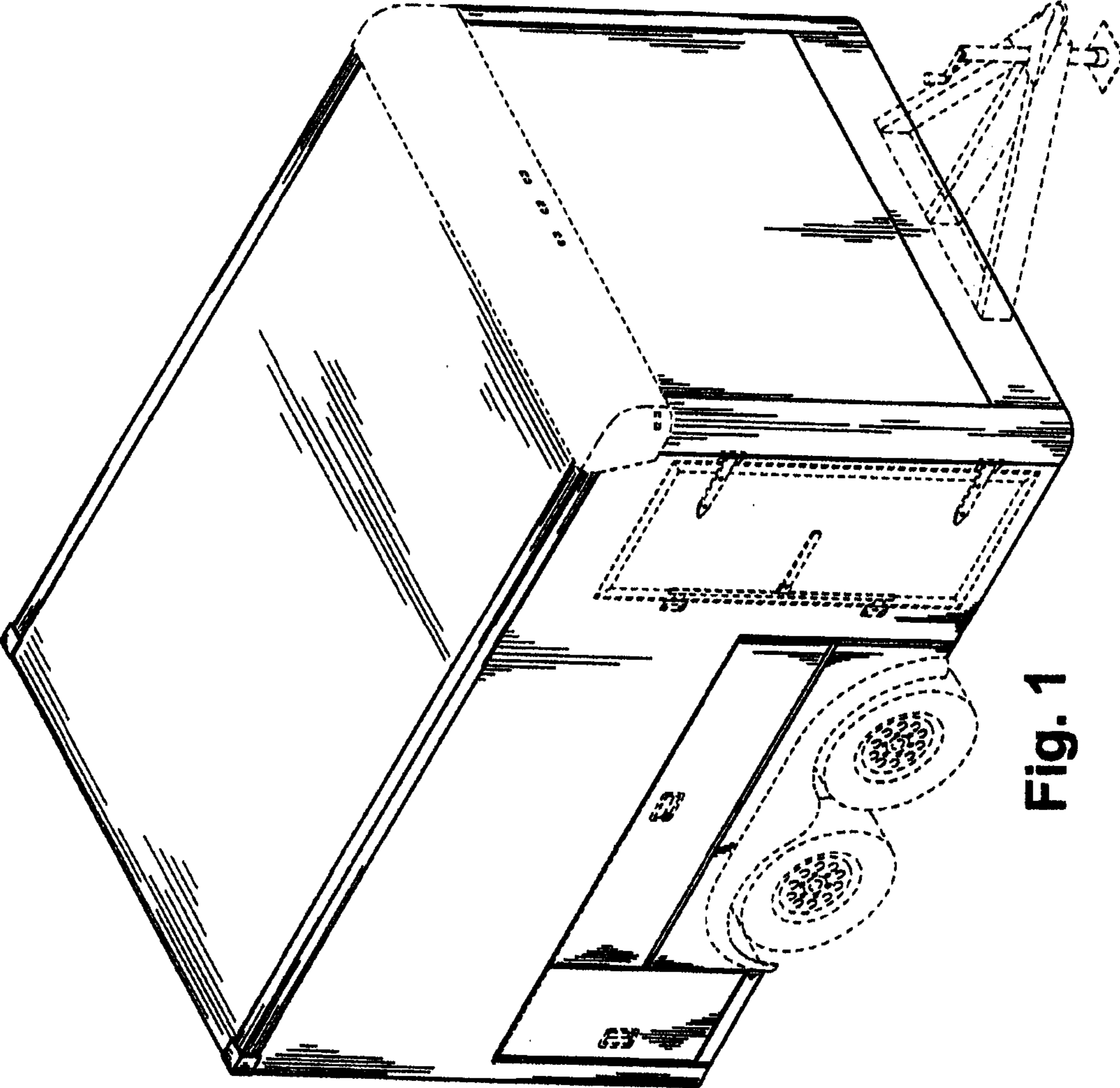

Fig. 1

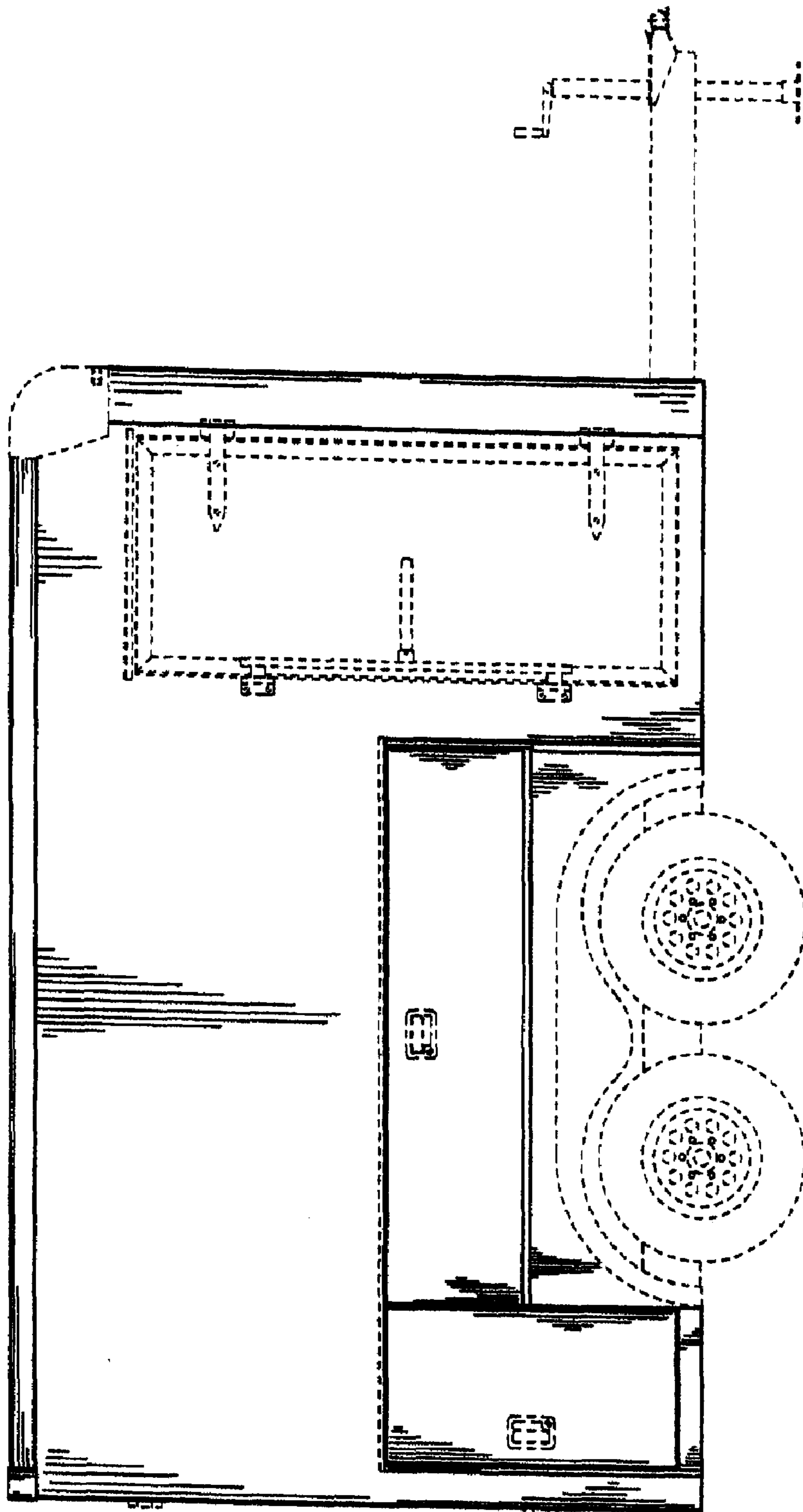

Fig. 2

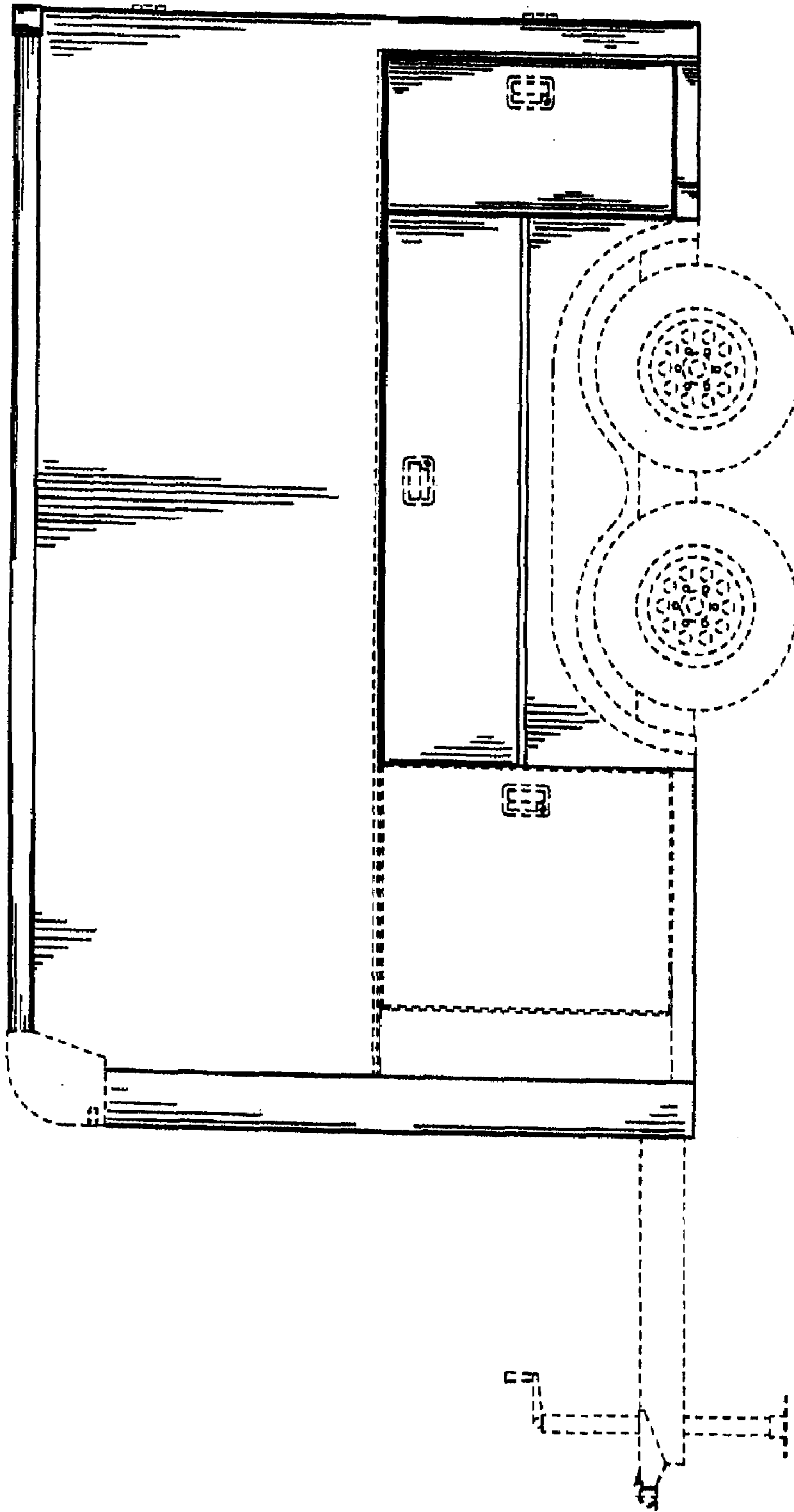

Fig. 3

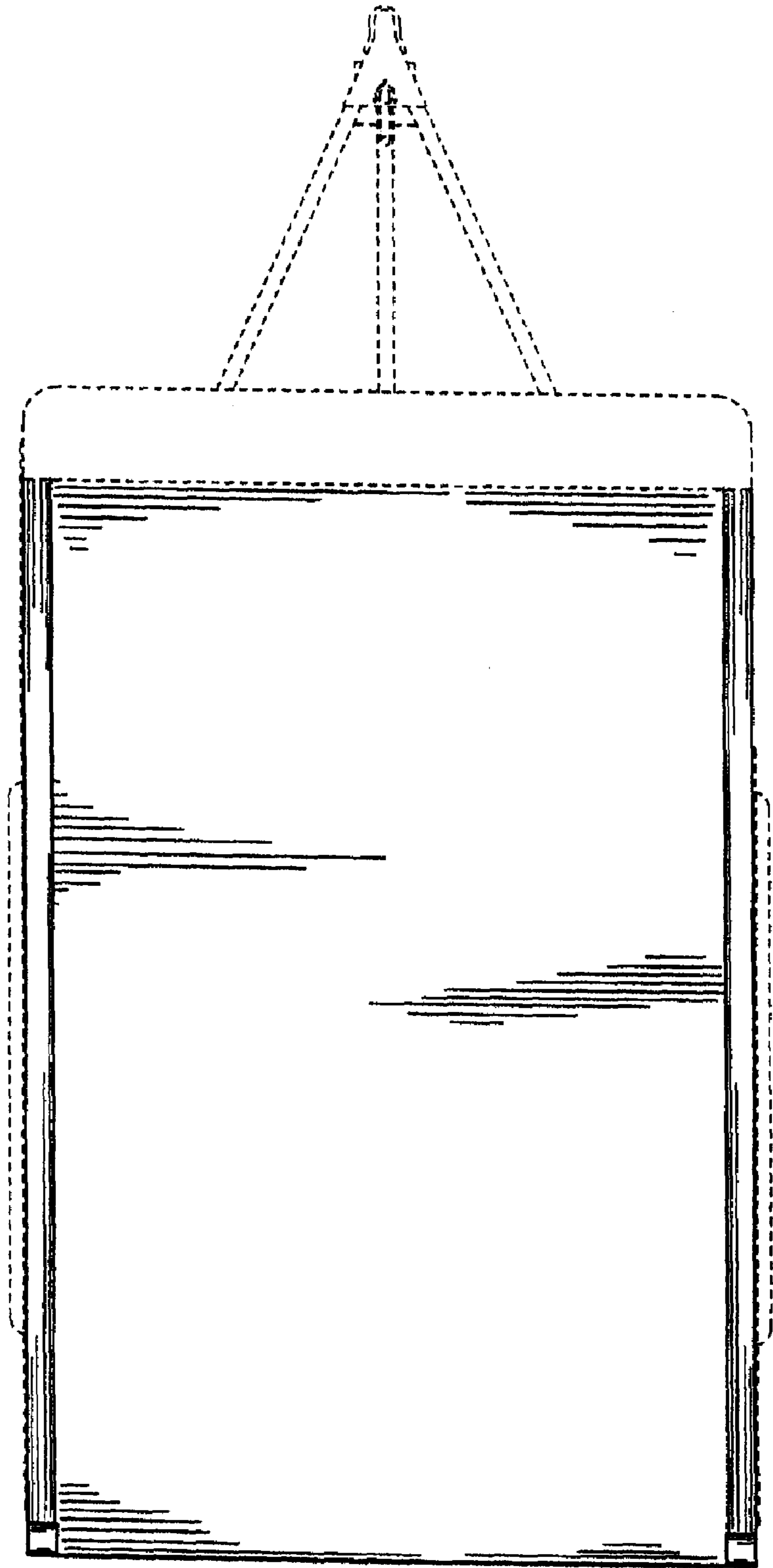

Fig. 4

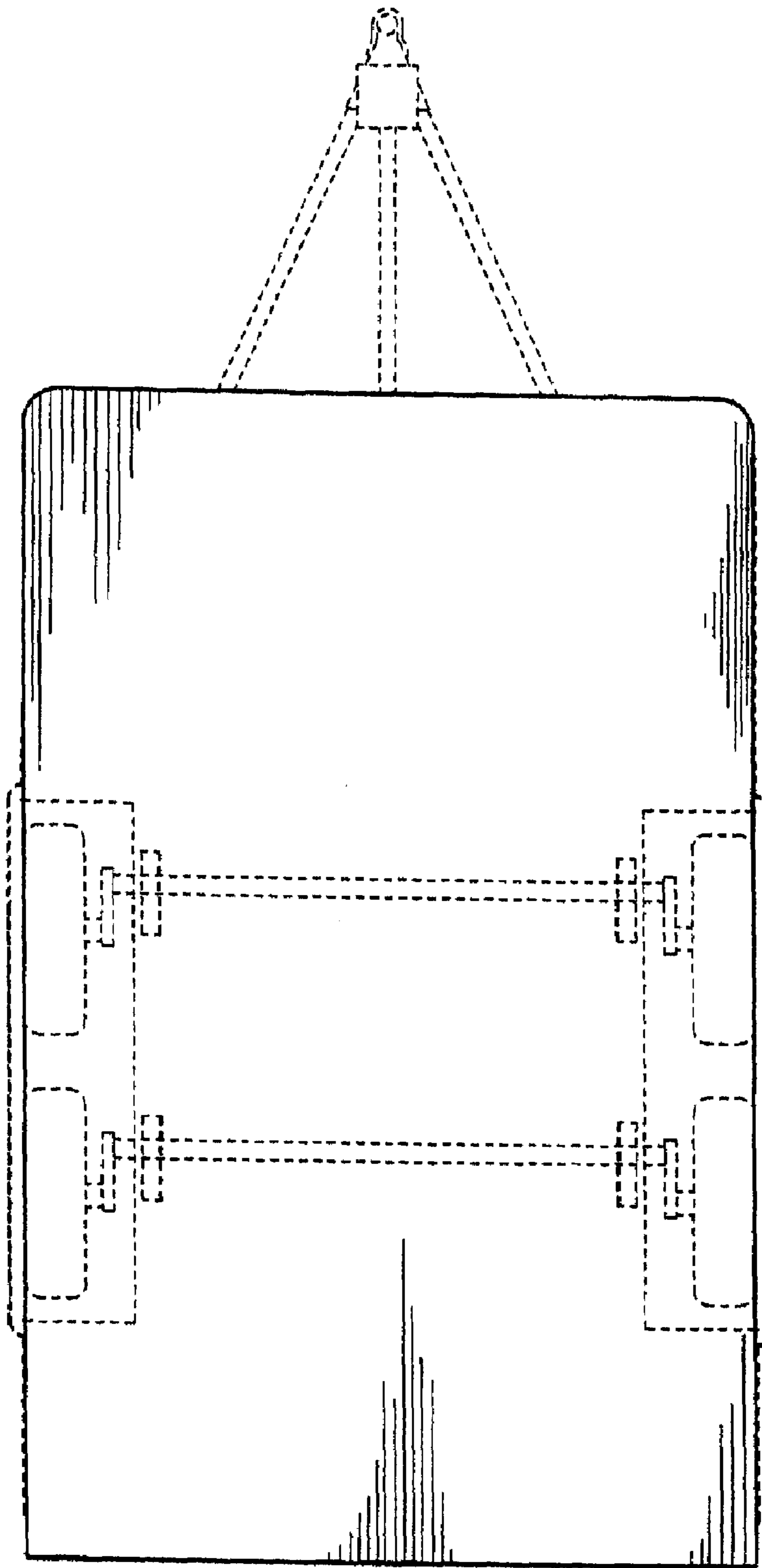

Fig. 5

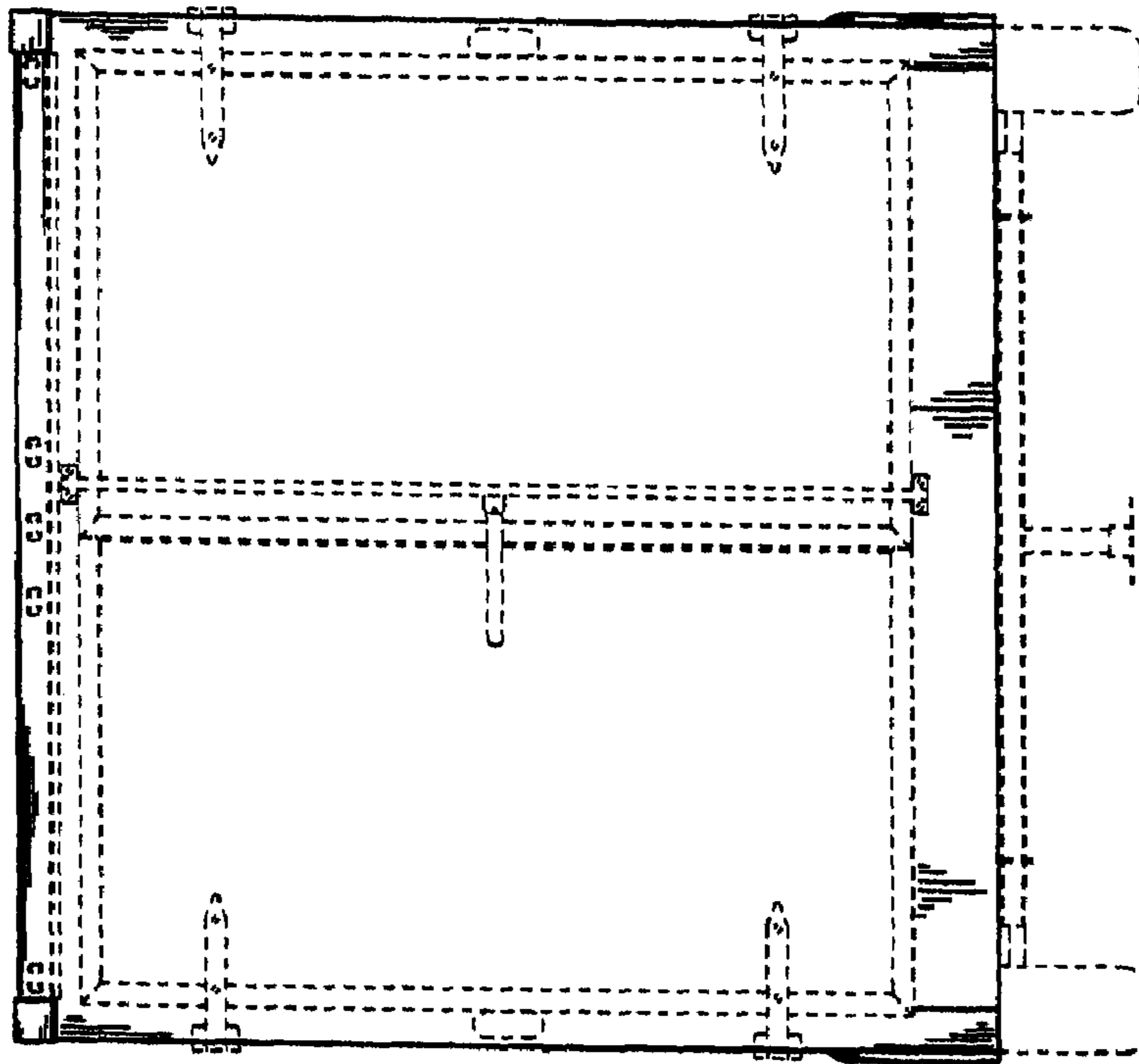

Fig. 6

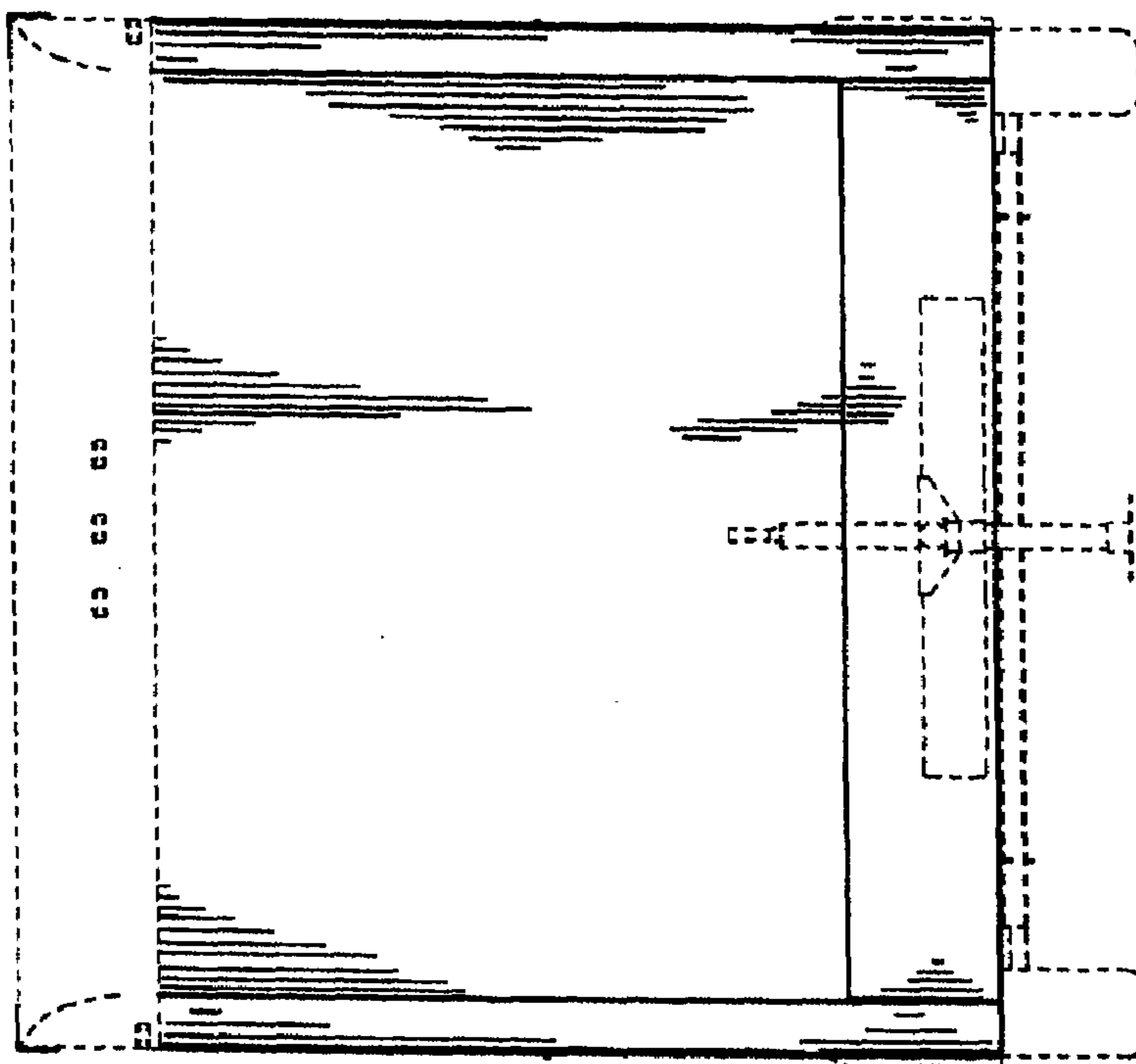

Fig. 7