



US00D560140S

(12) **United States Design Patent**
Crépeau

(10) **Patent No.:** **US D560,140 S**

(45) **Date of Patent:** **** Jan. 22, 2008**

(54) **ALL-TERRAIN VEHICLE BODY**

(75) Inventor: **Jean-Philippe Crépeau**, Bromont (CA)

(73) Assignee: **Bombardier Recreational Products Inc.**, Valcourt (CA)

(**) Term: **14 Years**

(21) Appl. No.: **29/236,923**

(22) Filed: **Aug. 25, 2005**

(51) **LOC (8) Cl.** **12-11**

(52) **U.S. Cl.** **D12/107**

(58) **Field of Classification Search** D12/3,
D12/86, 87, 107, 110, 169-171; 293/115,
293/146, 142-144, 149, 102, 112; 180/225,
180/229, 233, 311, 312, 315, 68.6
See application file for complete search history.

(56) **References Cited**

U.S. PATENT DOCUMENTS

D421,935 S * 3/2000 Fujieda D12/107
D496,308 S * 9/2004 Wu D12/107
D520,912 S * 5/2006 Knight et al. D12/107

* cited by examiner

Primary Examiner—Cathron Brooks

Assistant Examiner—Linda Brooks

(74) *Attorney, Agent, or Firm*—Osler, Hoskin & Harcourt LLP

(57) **CLAIM**

The ornamental design for an all-terrain vehicle body, as shown and described.

DESCRIPTION

FIG. 1 is a perspective view from the front and left side of an all-terrain vehicle body according to our design;

FIG. 2 is a front elevational view thereof;

FIG. 3 is a rear elevational view thereof;

FIG. 4 is a right side elevational view thereof;

FIG. 5 is a left side elevational view thereof;

FIG. 6 is a top plan view thereof; and,

FIG. 7 is a perspective view from the rear and left side thereof.

The broken lines immediately adjacent the shaded areas represent the bounds of the claimed design while all other broken lines are directed to environmental or structure and are for illustrative purposes only; all of the broken lines form no part of the claimed design.

1 Claim, 7 Drawing Sheets

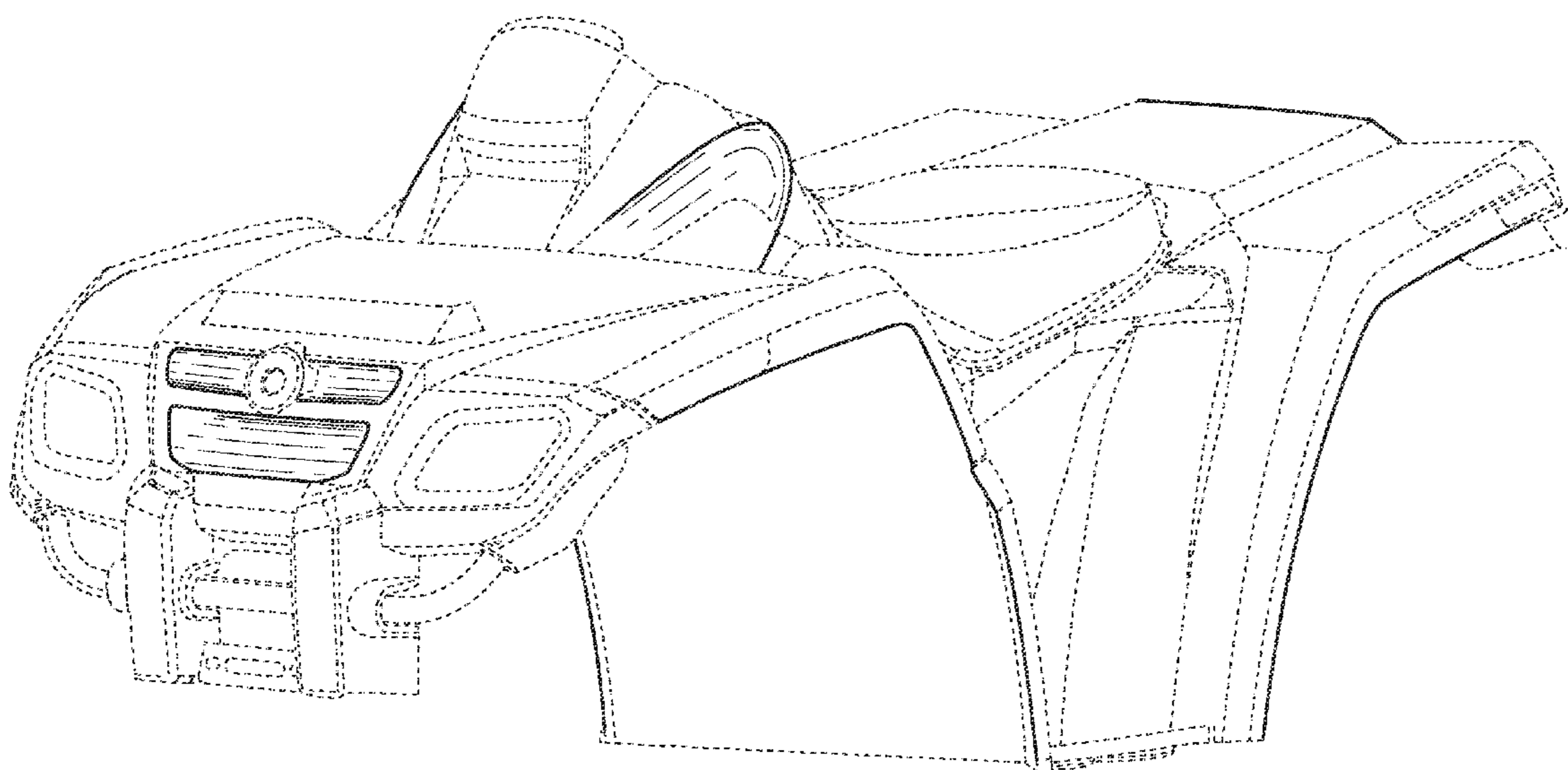

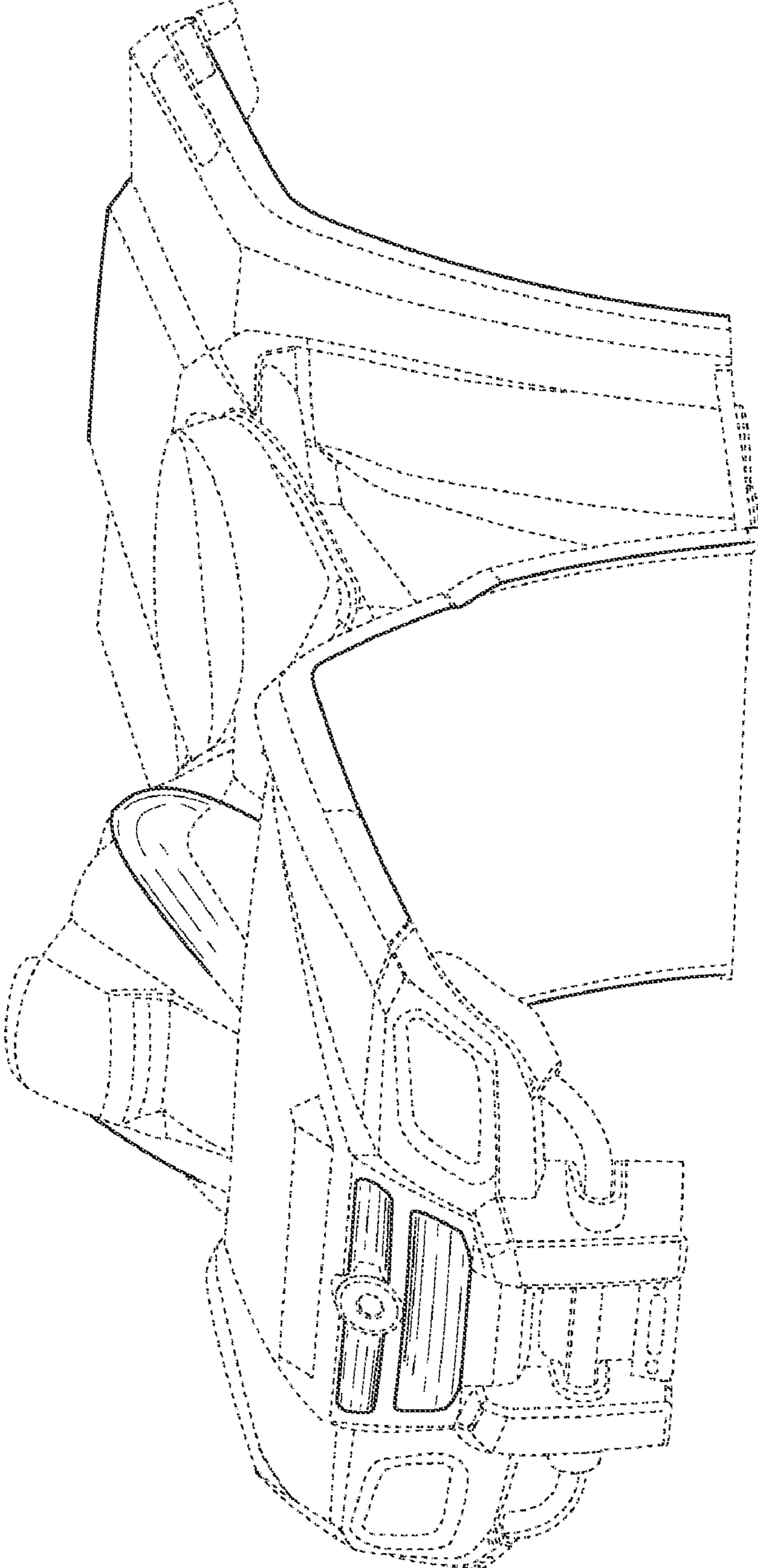

FIG. 1

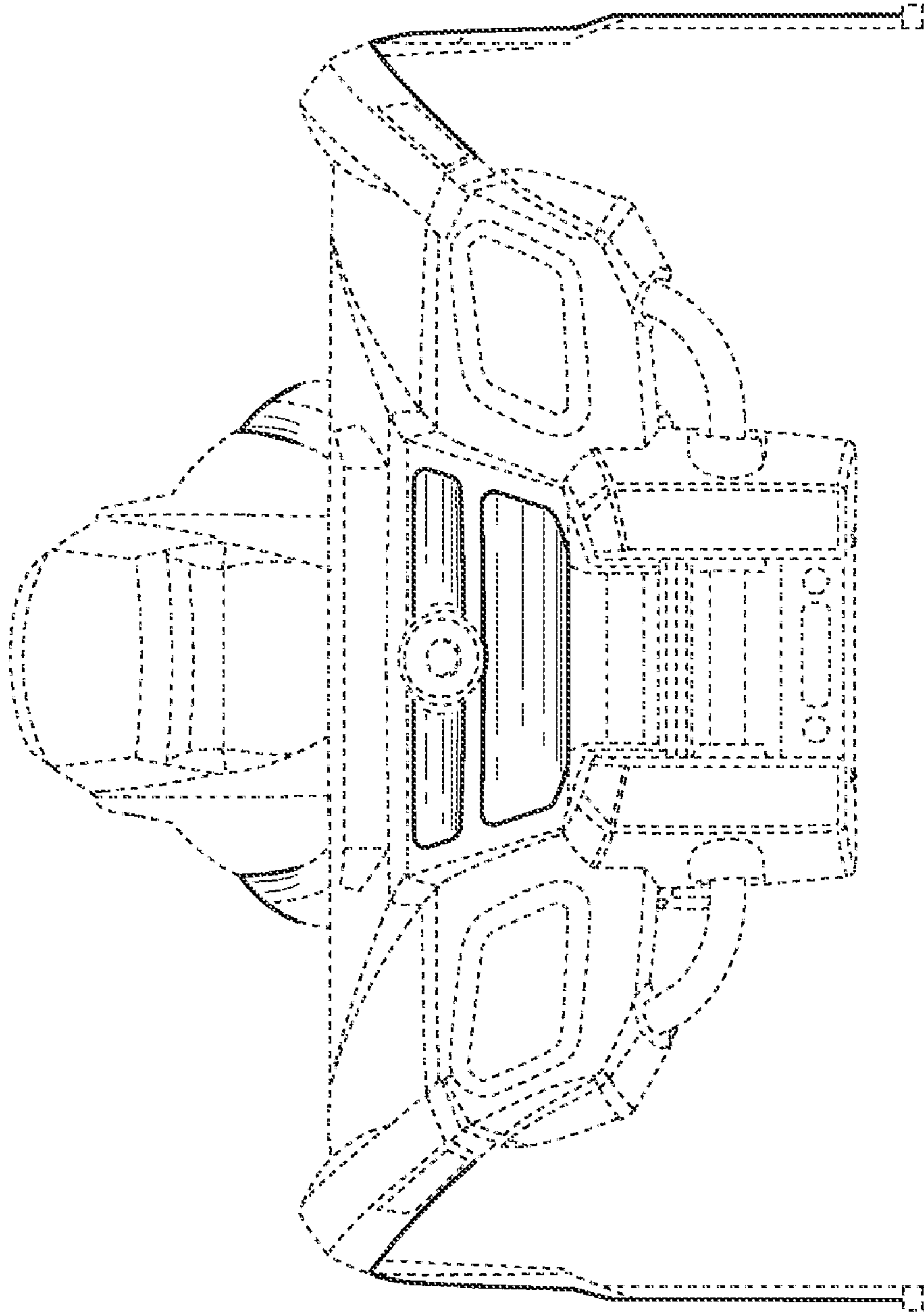

FIG. 2

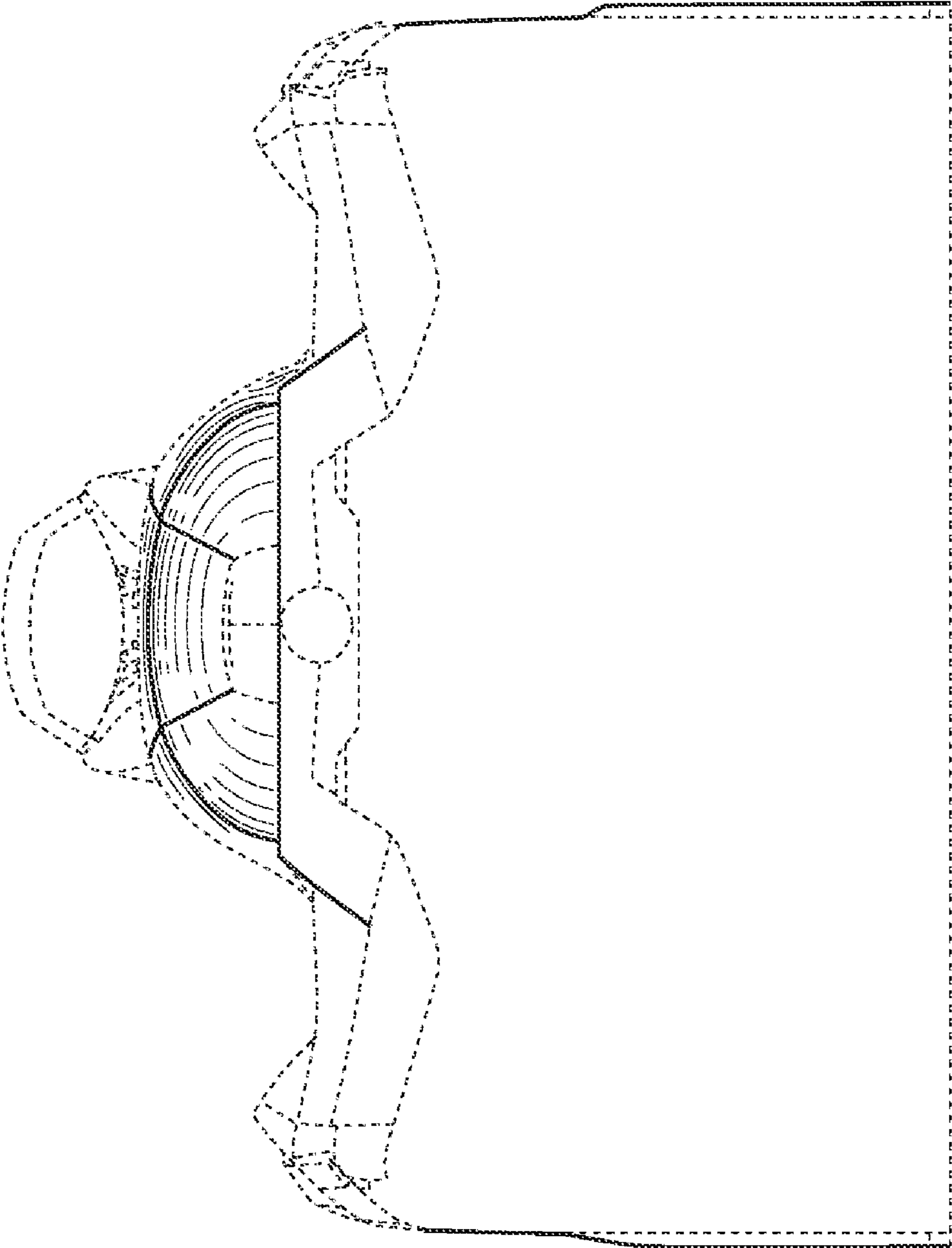

FIG. 3

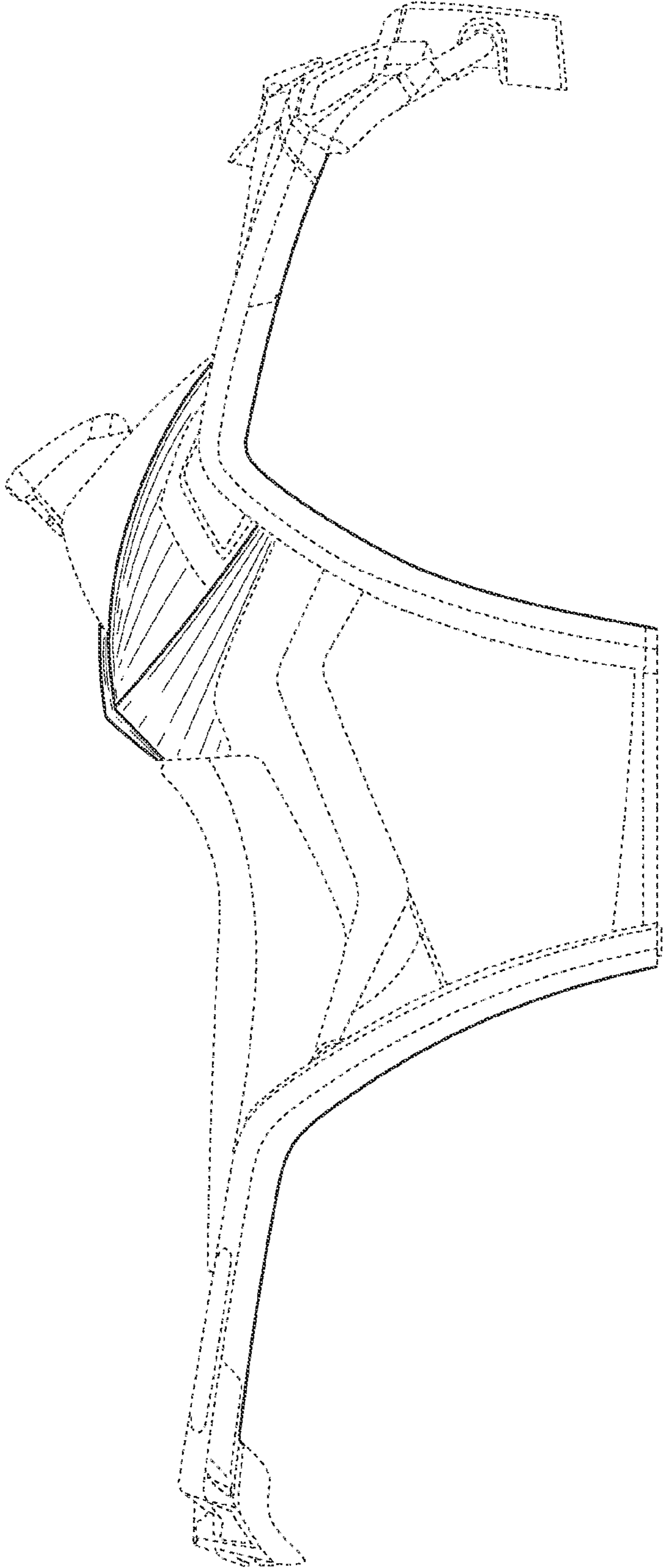

FIG. 4

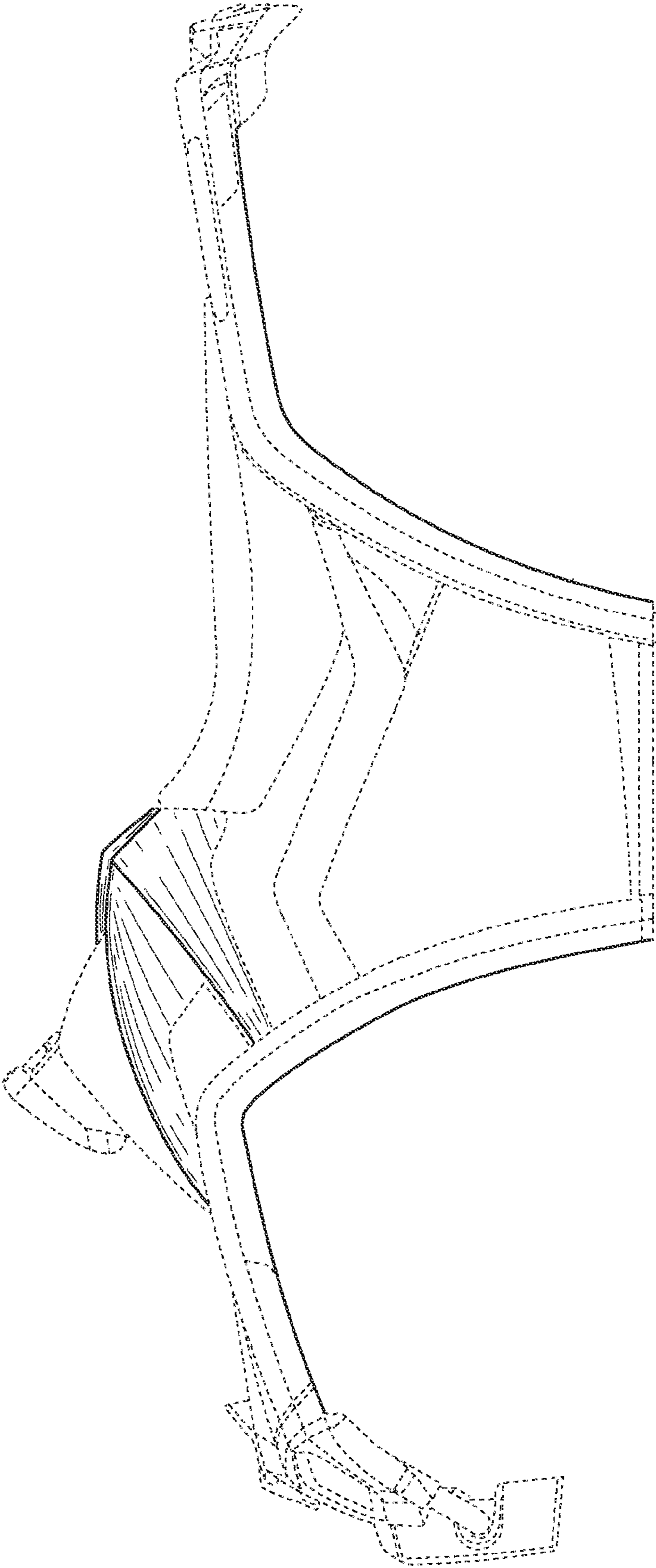

FIG. 5

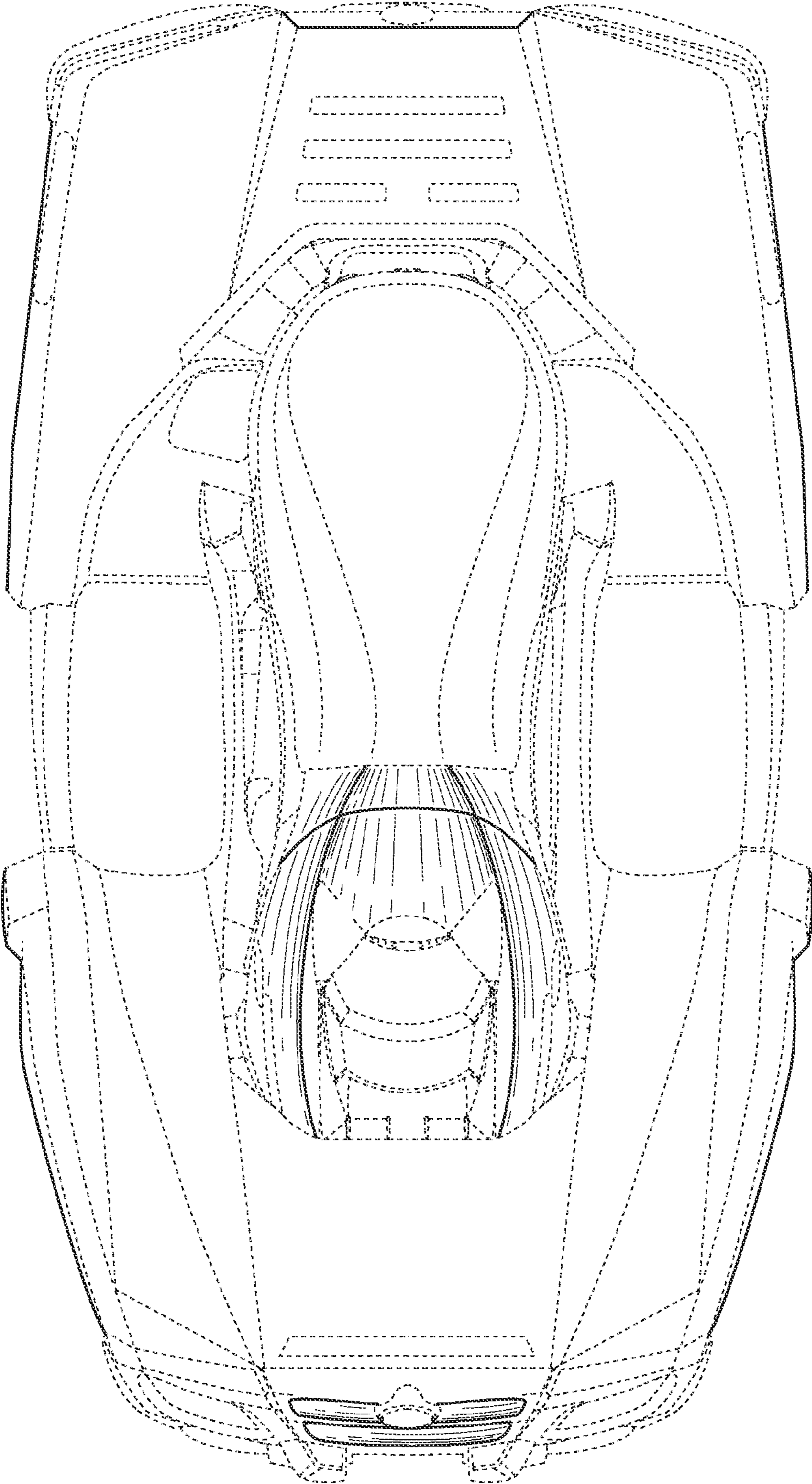

FIG. 6

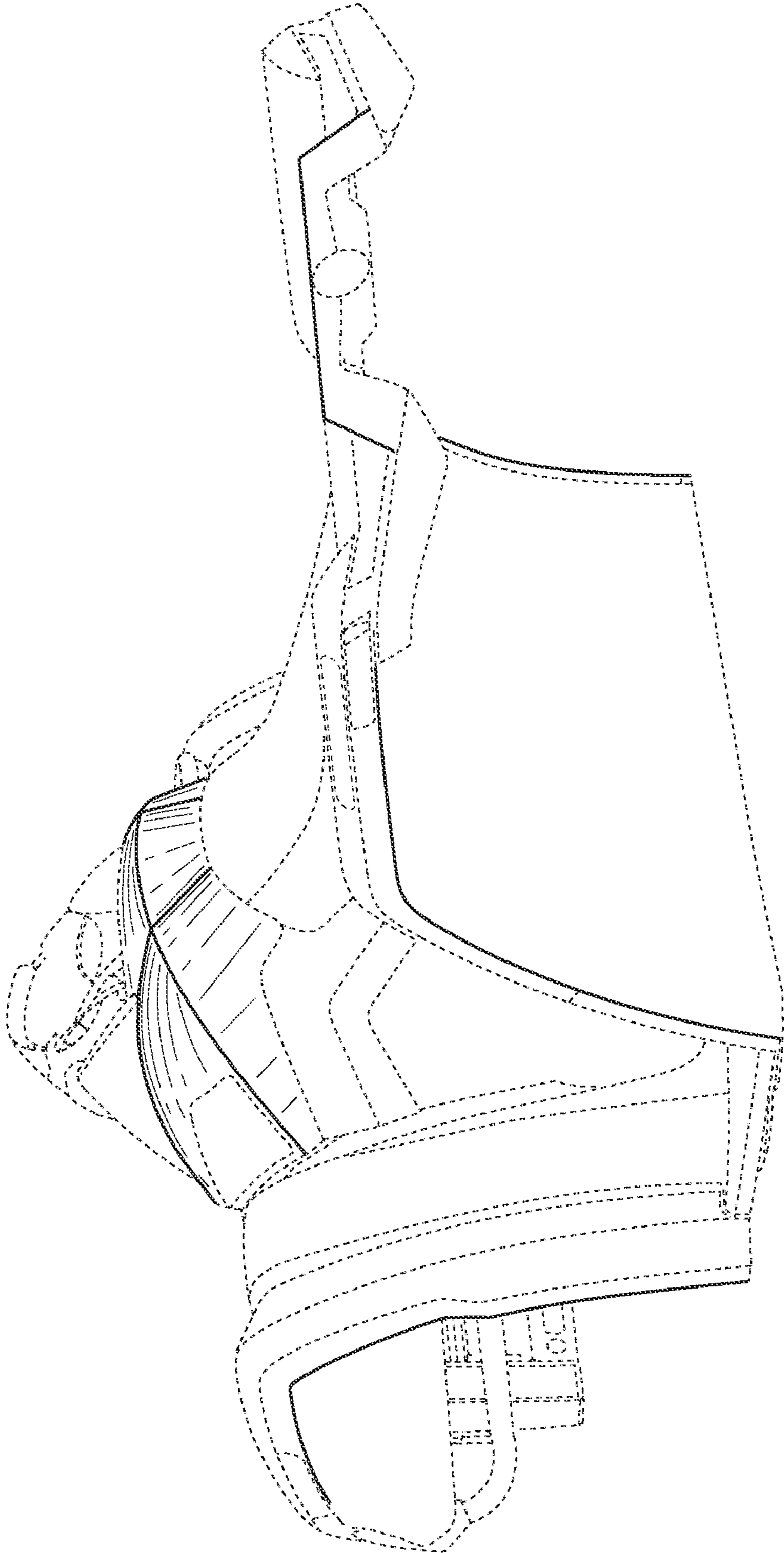

FIG. 7

UNITED STATES PATENT AND TRADEMARK OFFICE
CERTIFICATE OF CORRECTION

PATENT NO. : Des. 560,140 S
APPLICATION NO. : 29/236923
DATED : January 22, 2008
INVENTOR(S) : Jean-Phillippe Crépeau et al.

Page 1 of 9

It is certified that error appears in the above-identified patent and that said Letters Patent is hereby corrected as shown below:

The title page showing an illustrative fig. 1 should be deleted and substitute therefore the attached title page consisting of Fig. 1.

The drawing sheets 1-7 of 7 consisting of Fig(s) 1-7 should be deleted and substitute therefore the attached drawing sheets 1-7 of 7 consisting of Fig(s) 1-7.

Signed and Sealed this

Twenty-third Day of September, 2008

A handwritten signature in black ink that reads "Jon W. Dudas". The signature is written in a cursive style with a large, stylized initial "J".

JON W. DUDAS

Director of the United States Patent and Trademark Office

(12) United States Design Patent **(10) Patent No.: US D560,140 S**
Crépeau **(45) Date of Patent: ** Jan. 22, 2008**

(54) **ALL-TERRAIN VEHICLE BODY**
 (75) Inventor: **Jean-Philippe Crépeau, Bromont (CA)**
 (73) Assignee: **Bombardier Recreational Products Inc., Valcourt (CA)**
 (**) Term: **14 Years**
 (21) Appl. No.: **29/236,923**
 (22) Filed: **Aug. 25, 2005**

(51) LOC (8) Cl. **I2-II**
 (52) U.S. Cl. **D12/107**
 (58) Field of Classification Search **D12/3, D12/86, 87, 107, 110, 169-171; 293/115, 293/146, 142-144, 149, 102, 112; 180/225, 180/229, 233, 311, 312, 315, 68.6**
 See application file for complete search history.

(56) **References Cited**
U.S. PATENT DOCUMENTS
 D431,935 S * 3/2000 Fujiwara D12/107
 D496,308 S * 9/2004 Wu D12/107
 D520,912 S * 5/2006 Knight et al. D12/107

* cited by examiner
Primary Examiner—Cathron Brooks
Assistant Examiner—Linda Brooks

(74) *Attorney, Agent, or Firm*—Osler, Hoskin & Harcourt LLP

(57) **CLAIM**

The ornamental design for an all-terrain vehicle body, as shown and described.

DESCRIPTION

FIG. 1 is a perspective view from the front and left side of an all-terrain vehicle body according to our design;
 FIG. 2 is a front elevational view thereof;
 FIG. 3 is a rear elevational view thereof;
 FIG. 4 is a right side elevational view thereof;
 FIG. 5 is a left side elevational view thereof;
 FIG. 6 is a top plan view thereof; and,
 FIG. 7 is a perspective view from the rear and left side thereof.

The broken lines immediately adjacent the shaded areas represent the bounds of the claimed design while all other broken lines are directed to environmental or structure and are for illustrative purposes only; all of the broken lines form no part of the claimed design.

1 Claim, 7 Drawing Sheets

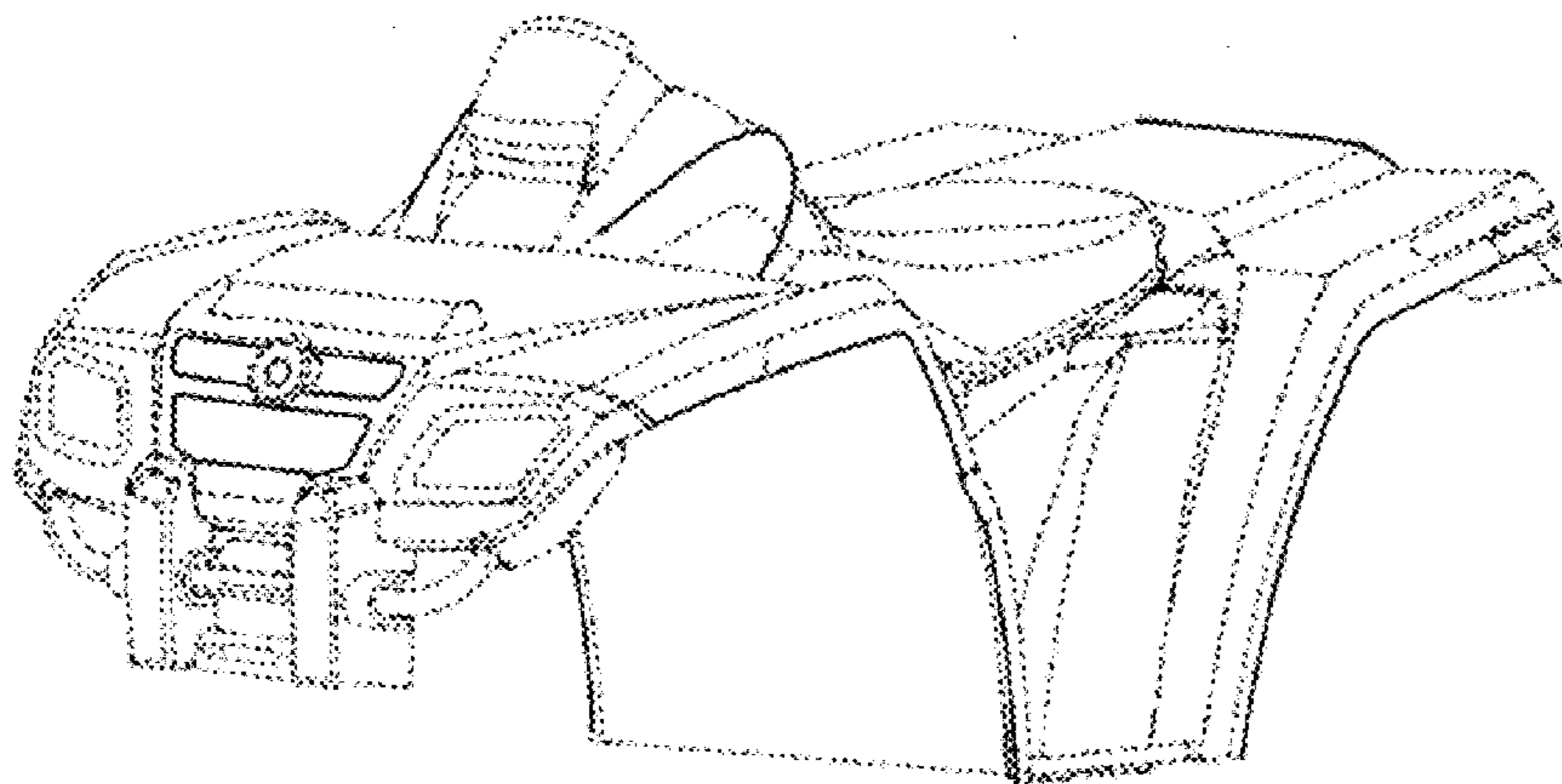

U.S. Patent

Jan. 22, 2008

Sheet 1 of 7

D560,140 S

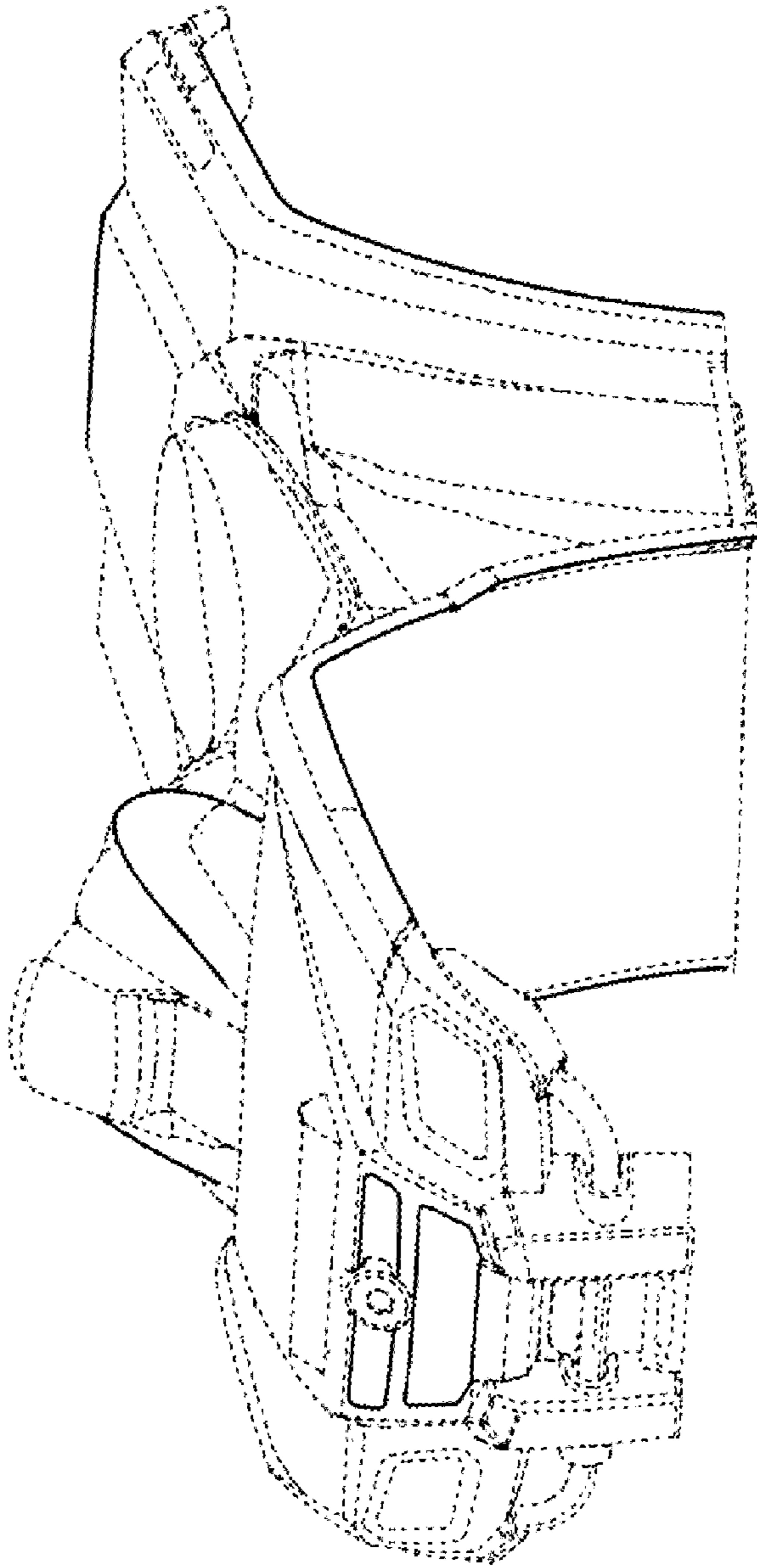

FIG. 1

U.S. Patent

Jan. 22, 2008

Sheet 2 of 7

D560,140 S

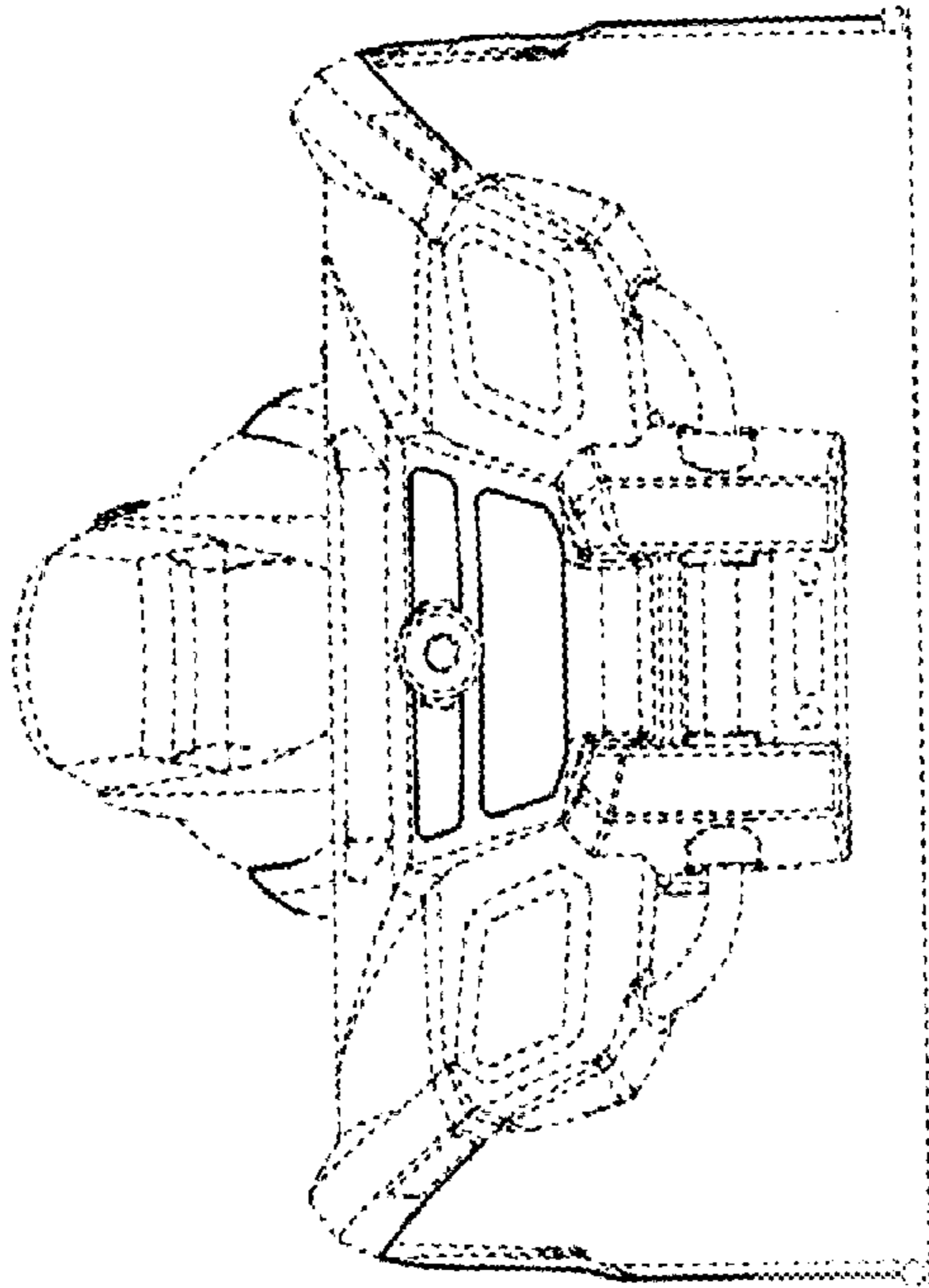

FIG. 2

U.S. Patent

Jan. 22, 2008

Sheet 3 of 7

D560,140 S

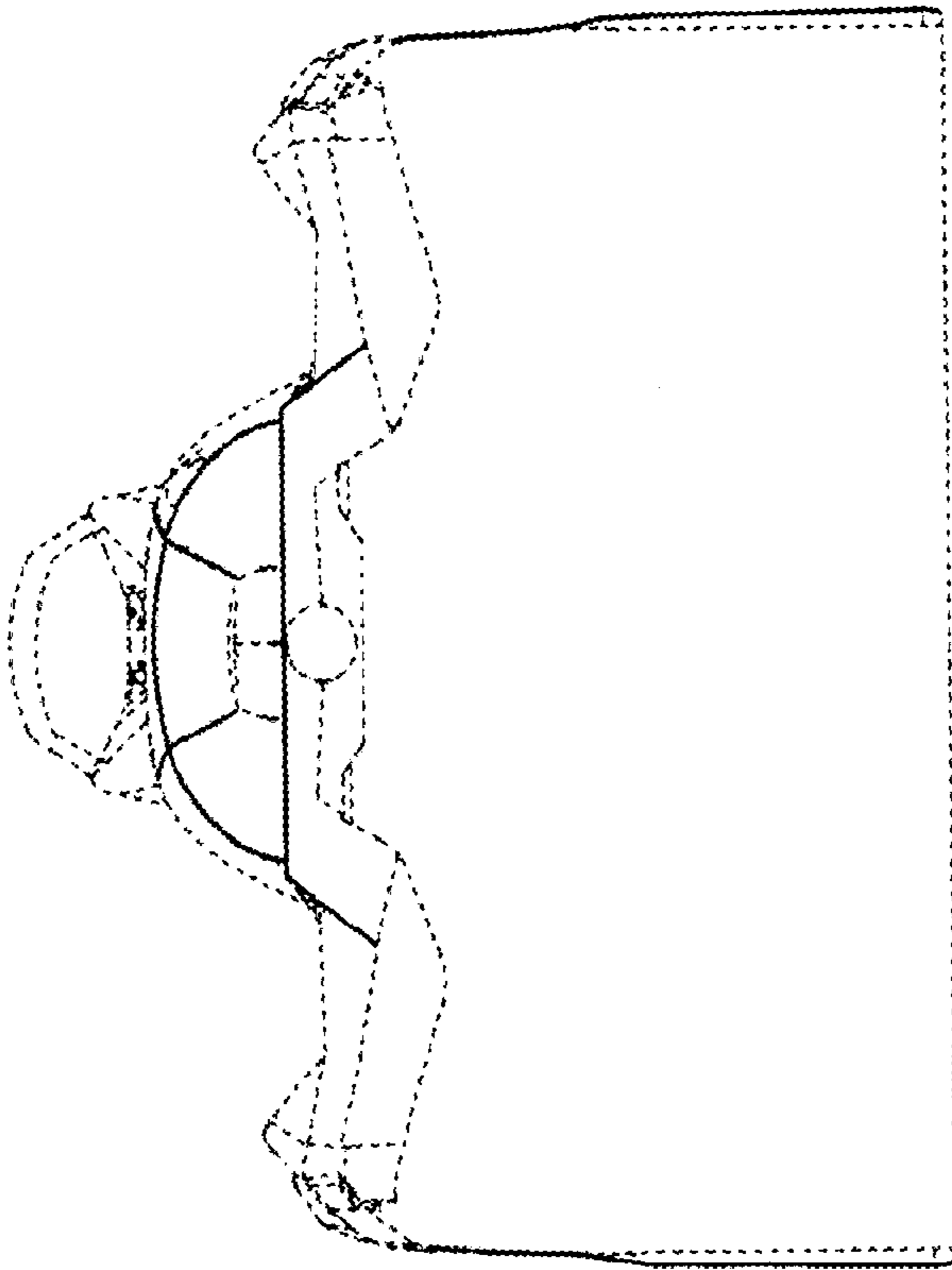

FIG. 3

U.S. Patent

Jan. 22, 2008

Sheet 4 of 7

D560,140 S

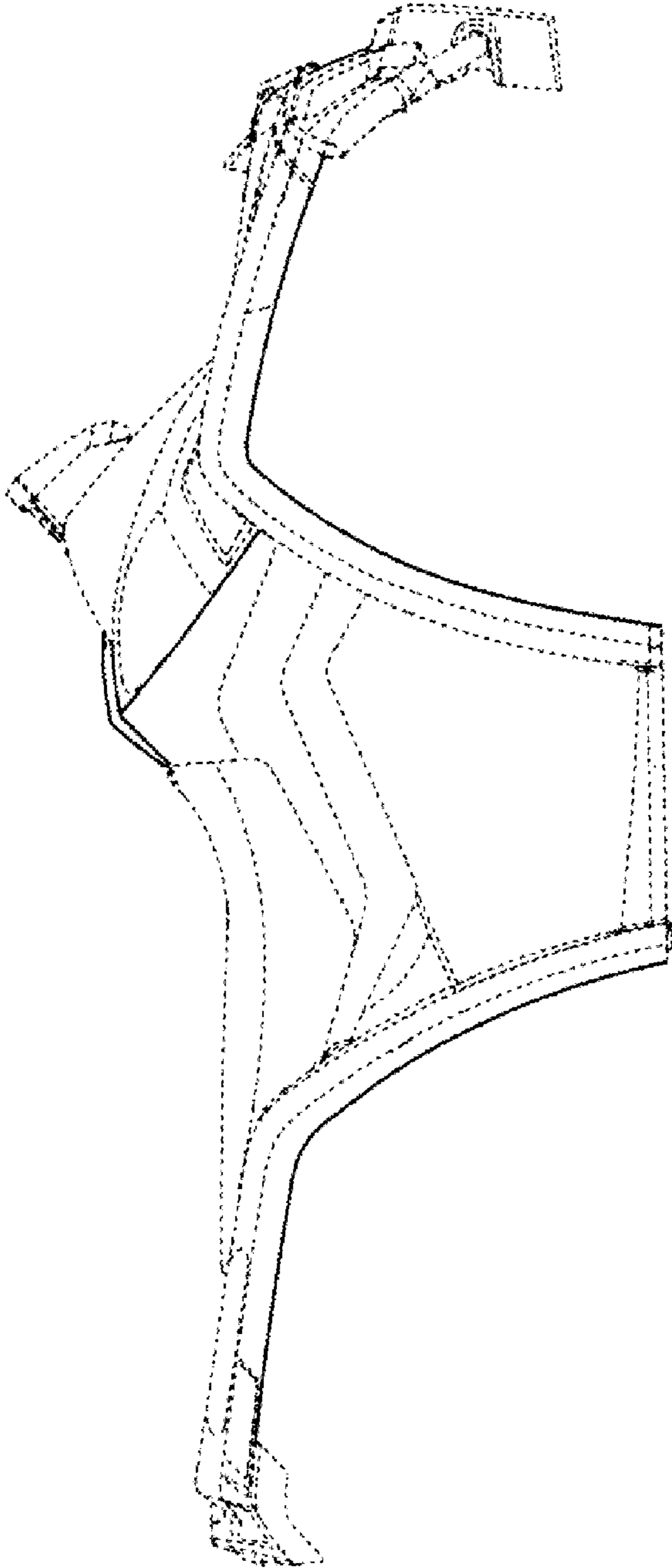

FIG. 4

U.S. Patent

Jan. 22, 2008

Sheet 5 of 7

D560,140 S

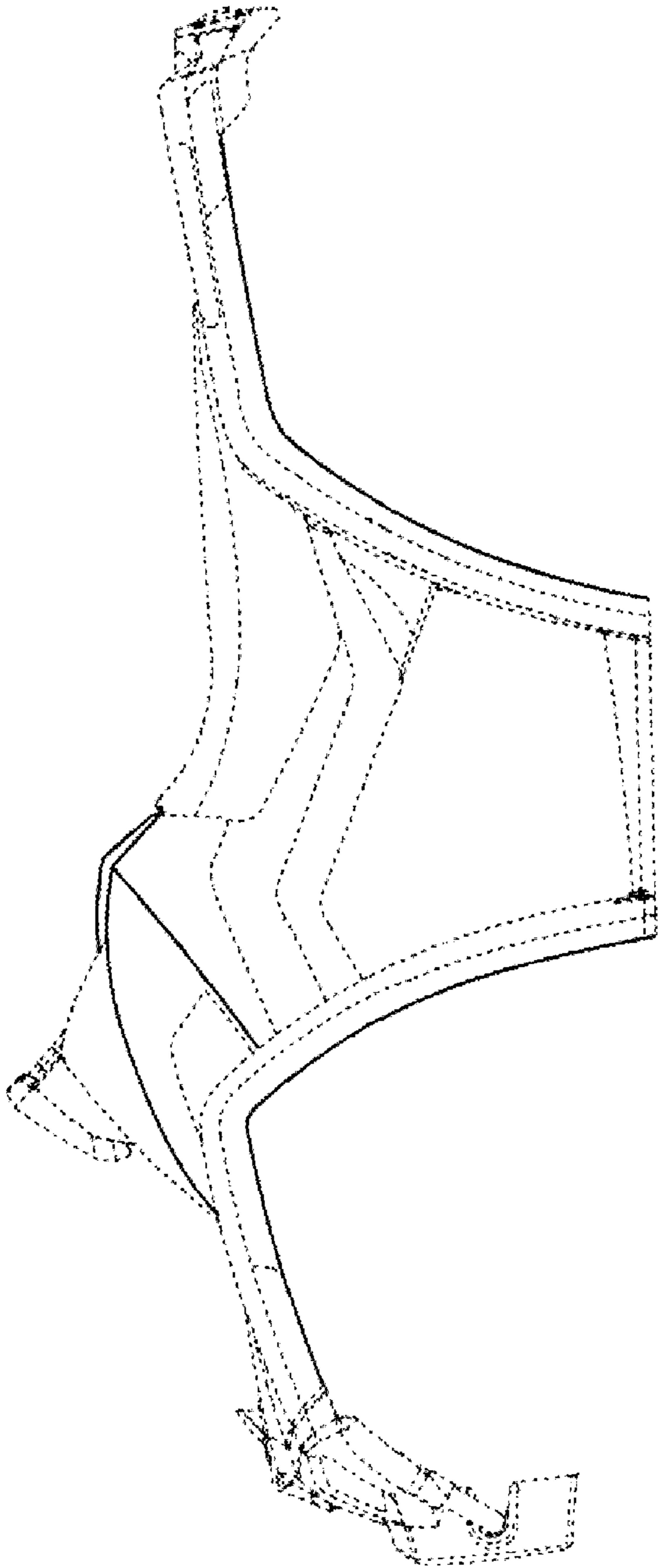

FIG. 5

U.S. Patent

Jan. 22, 2008

Sheet 6 of 7

D560,140 S

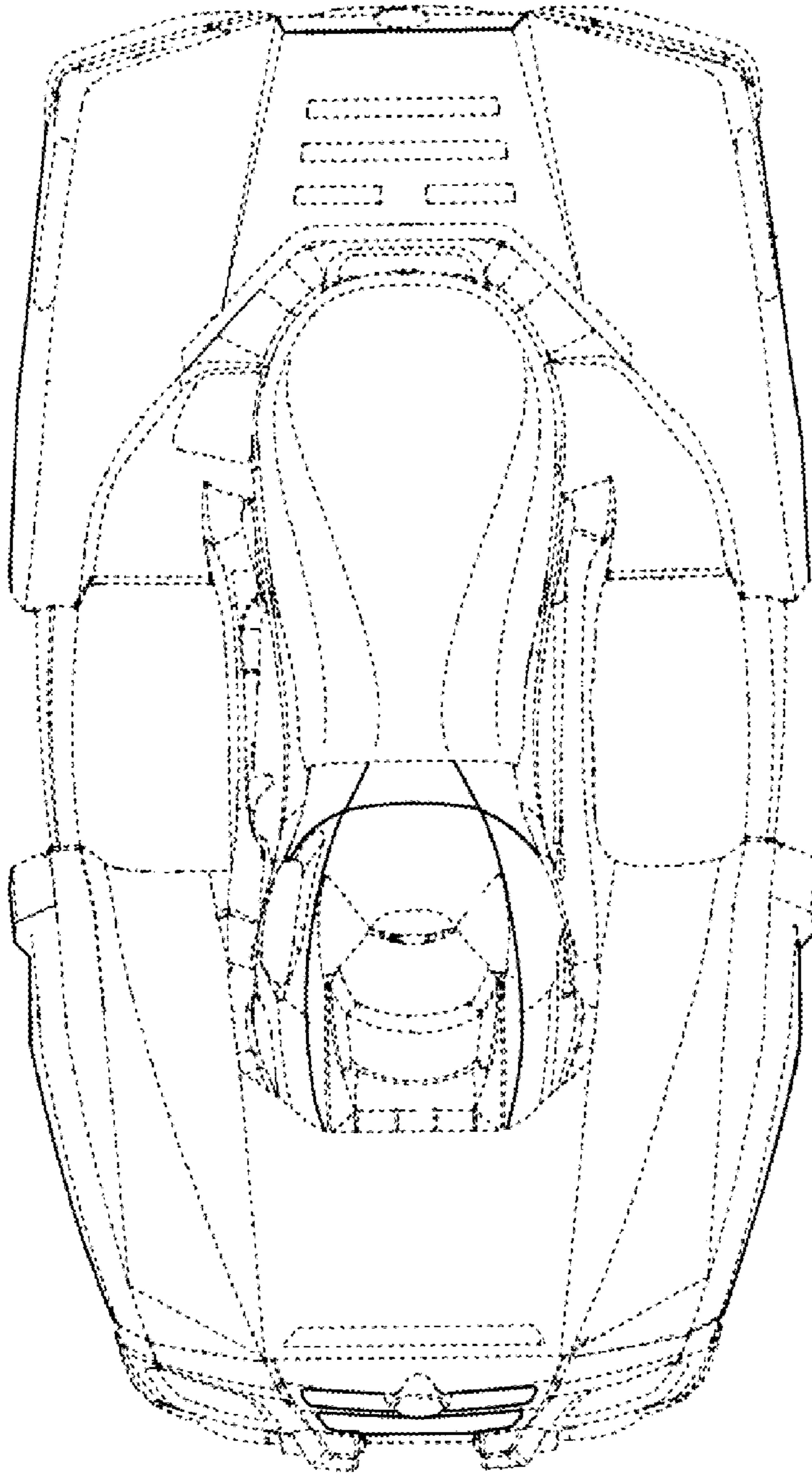

FIG. 6

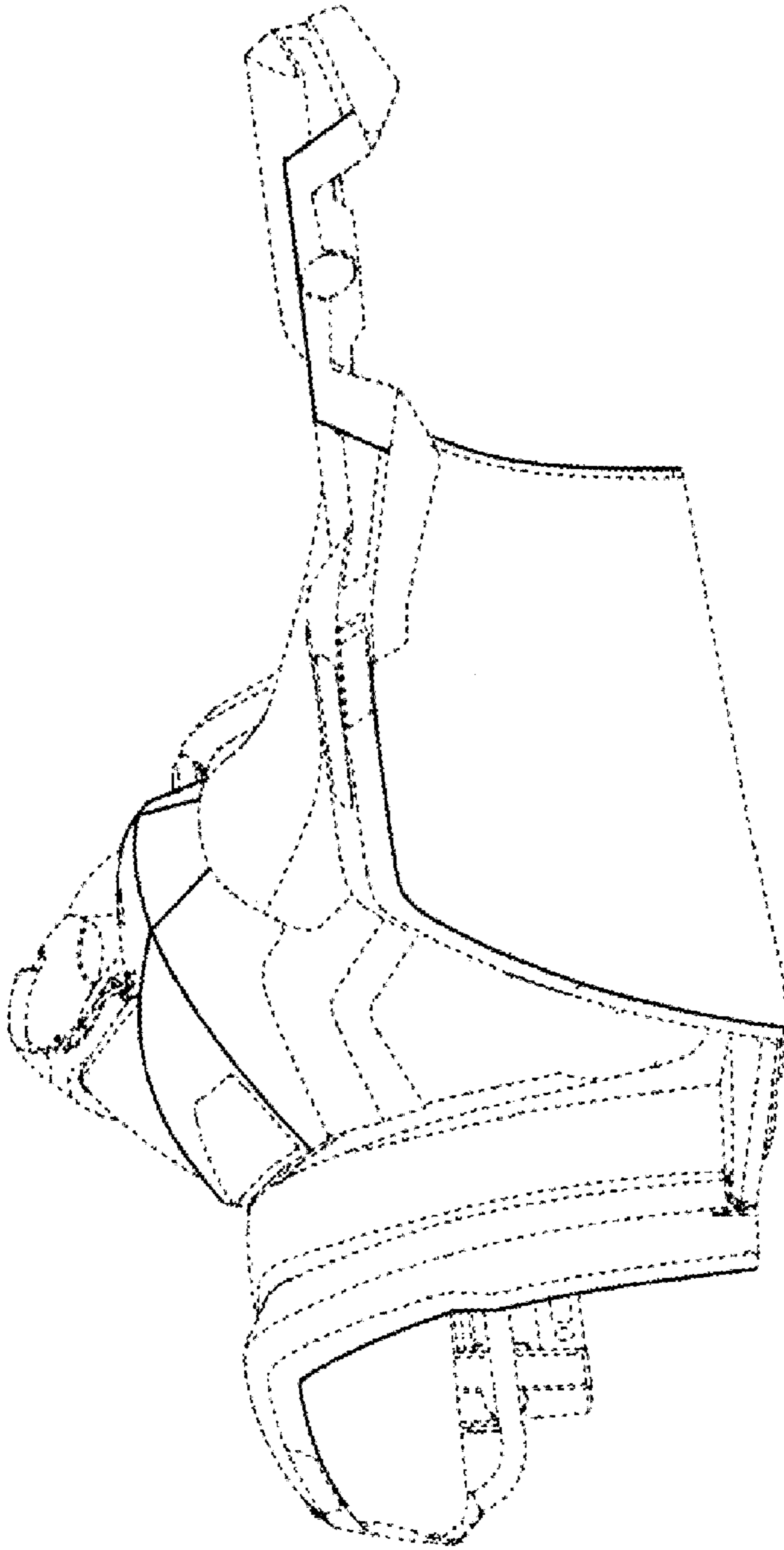

FIG. 7