



US00D560139S

(12) **United States Design Patent**
Crépeau

(10) **Patent No.:** **US D560,139 S**

(45) **Date of Patent:** **** *Jan. 22, 2008**

(54) **ALL-TERRAIN VEHICLE BODY**

(75) Inventor: **Jean-Philippe Crépeau**, Bromont (CA)

(73) Assignee: **Bombardier Recreational Products Inc.**, Valcourt (CA)

(*) Notice: This patent is subject to a terminal disclaimer.

(**) Term: **14 Years**

(21) Appl. No.: **29/236,918**

(22) Filed: **Aug. 25, 2005**

(51) **LOC (8) Cl.** **12-11**

(52) **U.S. Cl.** **D12/107**

(58) **Field of Classification Search** D12/3,
D12/86, 87, 107, 110, 169-171; 293/115,
293/146, 142-144, 149, 102, 112; 180/225,
180/229, 233, 311, 312, 315, 68.6
See application file for complete search history.

(56) **References Cited**

U.S. PATENT DOCUMENTS

- D421,935 S * 3/2000 Fujieda D12/107
- D496,308 S * 9/2004 Wu D12/107
- D520,912 S * 5/2006 Knight et al. D12/107

* cited by examiner

Primary Examiner—Cathron Brooks

Assistant Examiner—Linda Brooks

(74) *Attorney, Agent, or Firm*—Osler, Hoskin & Harcourt LLP

(57) **CLAIM**

The ornamental design for an all-terrain vehicle body, as shown and described.

DESCRIPTION

FIG. 1 is a perspective view from the front and left side of an all-terrain vehicle body according to our design;

FIG. 2 is a front elevational view thereof;

FIG. 3 is a rear elevational view thereof;

FIG. 4 is a right side elevational view thereof;

FIG. 5 is a left side elevational view thereof;

FIG. 6 is a top plan view thereof; and,

FIG. 7 is a perspective view from the rear and left side thereof.

The broken lines immediately adjacent the shaded areas represent the bounds of the claimed design while all other broken lines are directed to environmental structure and are for illustrative purposes only; all of the broken lines form no part of the claimed design.

1 Claim, 7 Drawing Sheets

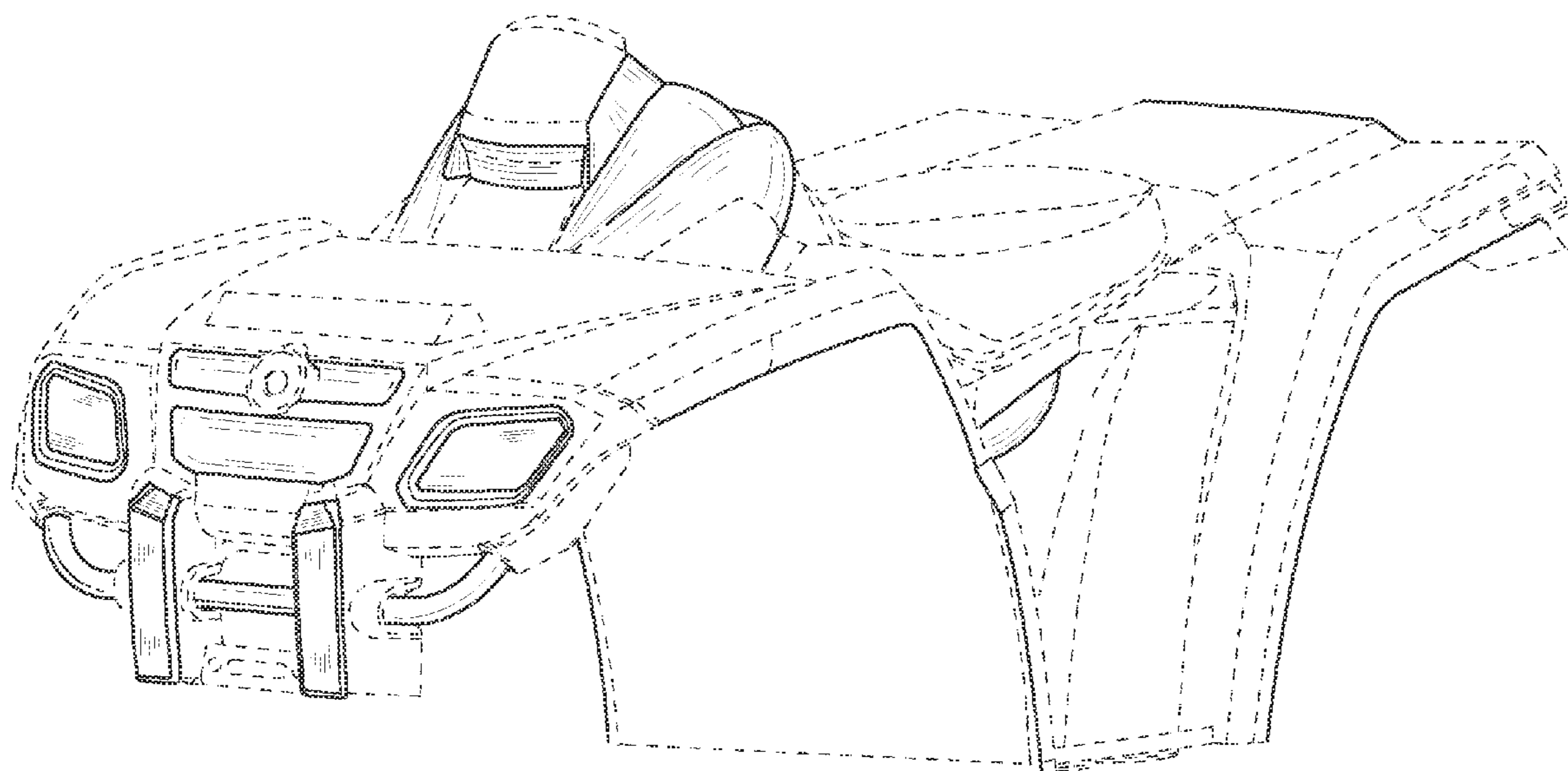

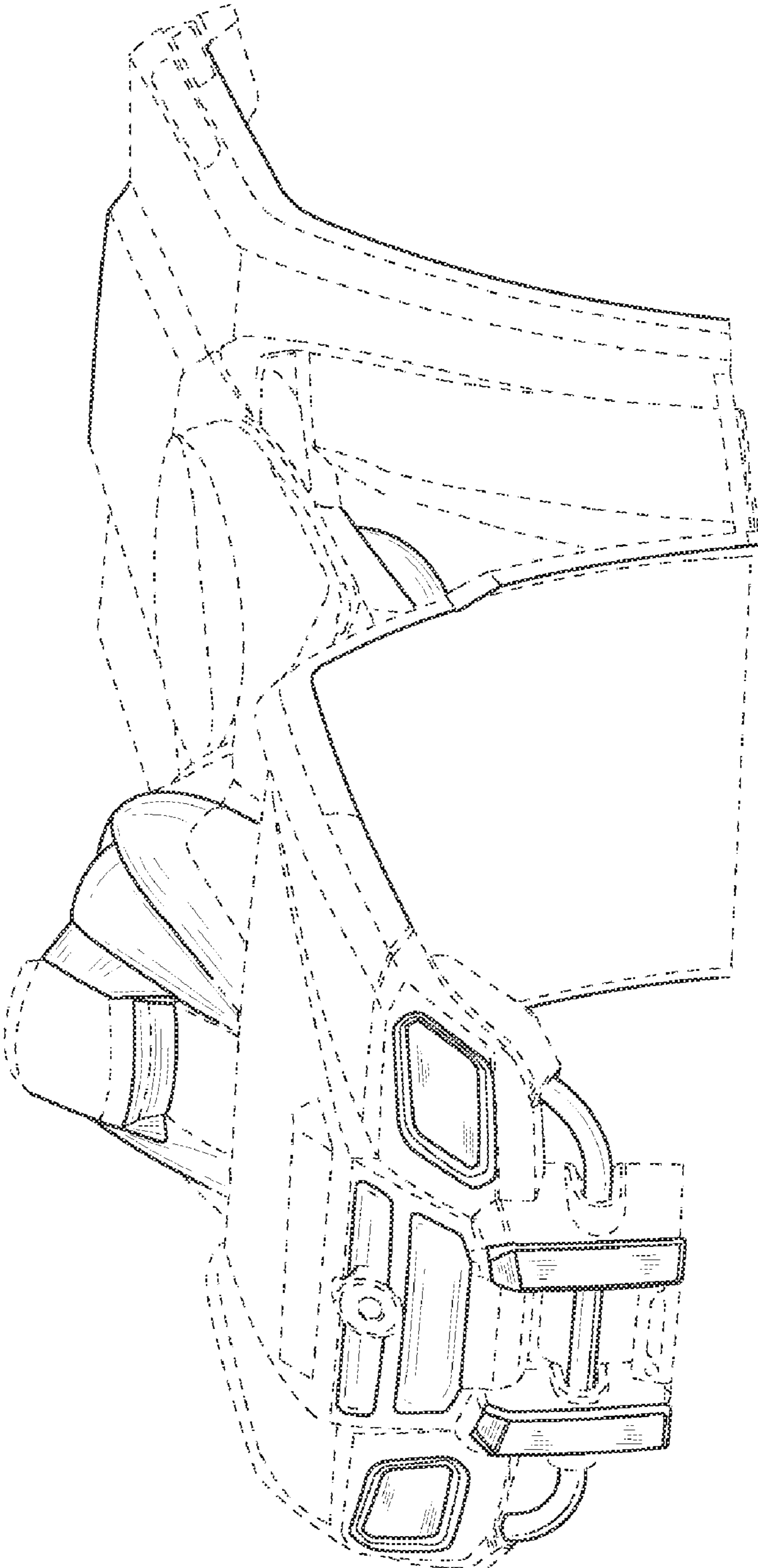

FIG. 1

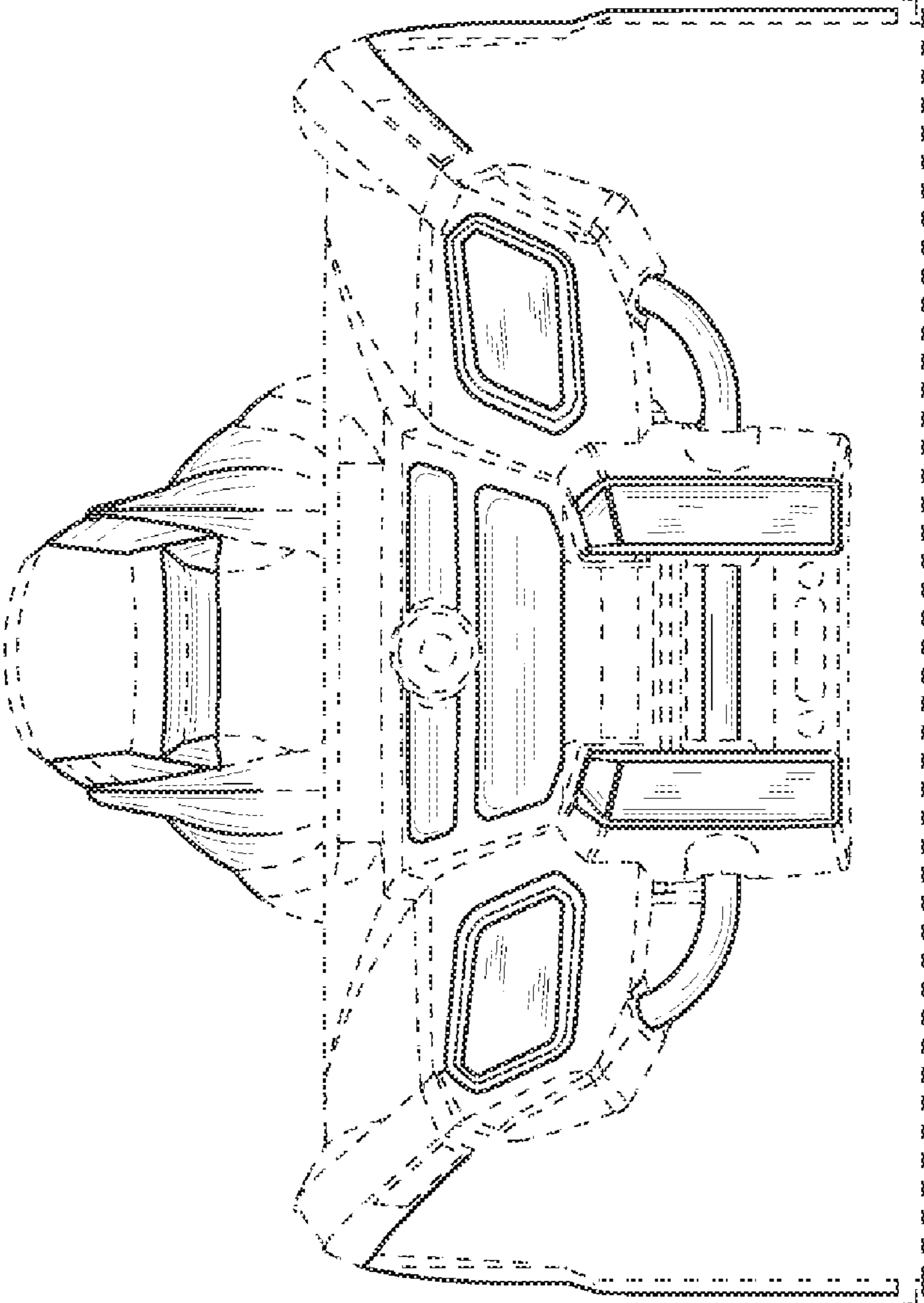

FIG. 2

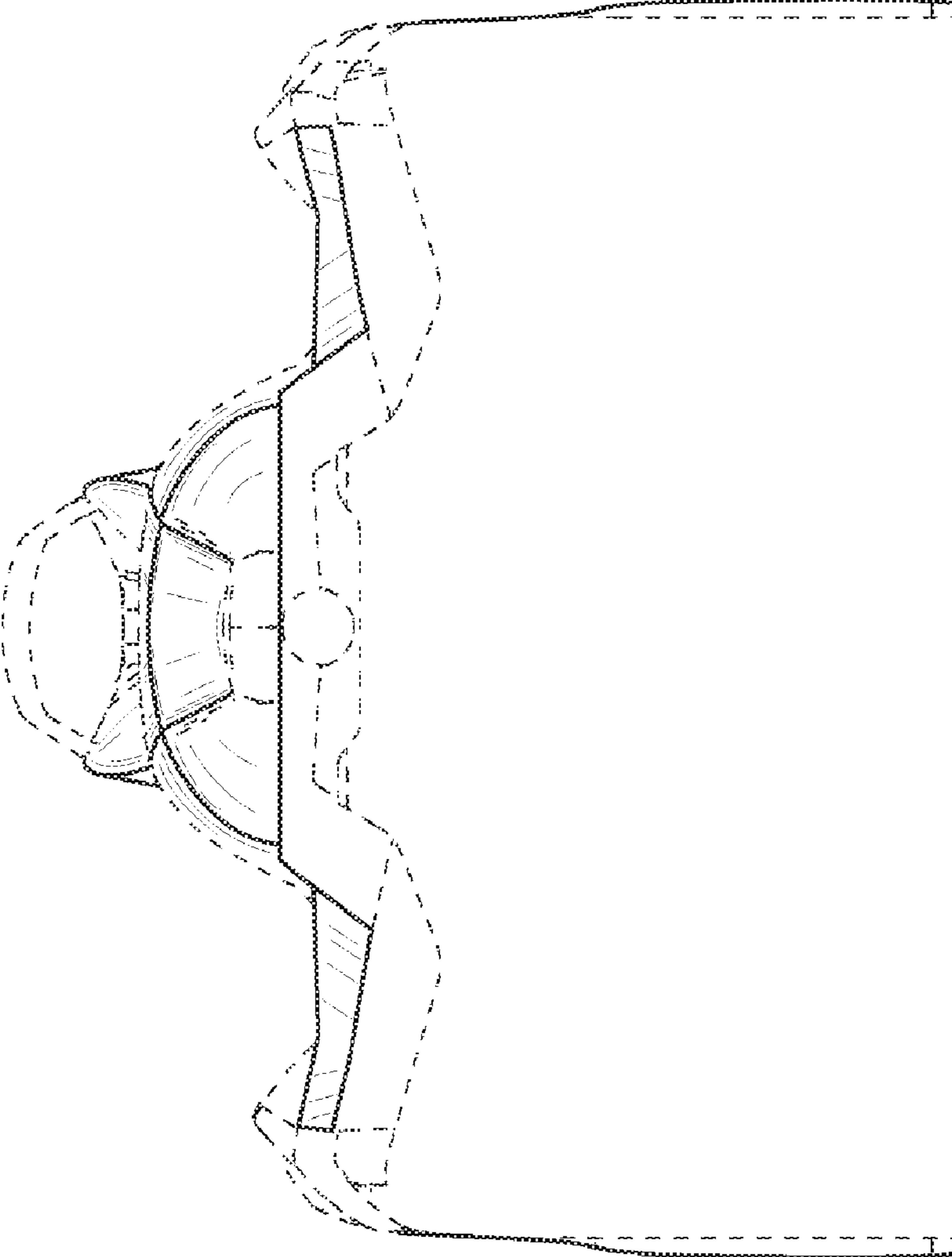

FIG. 3

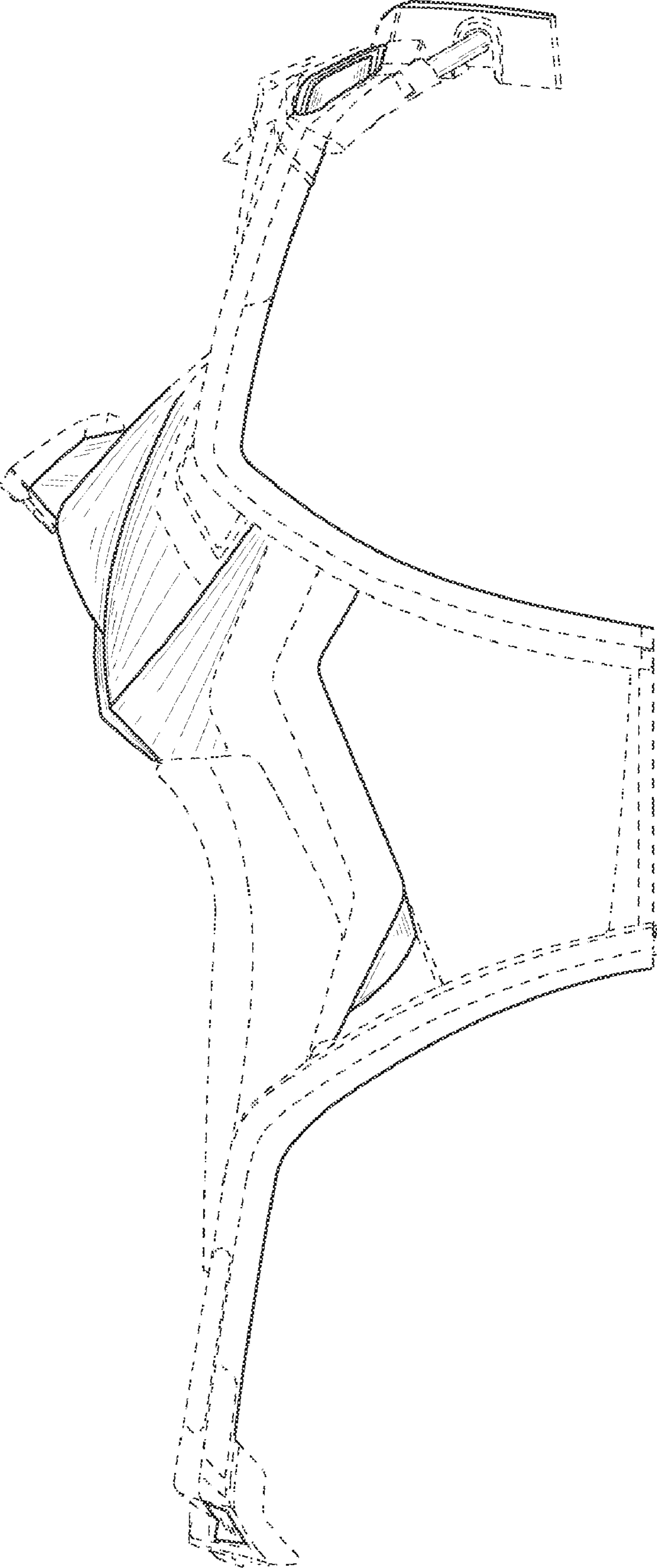

FIG. 4

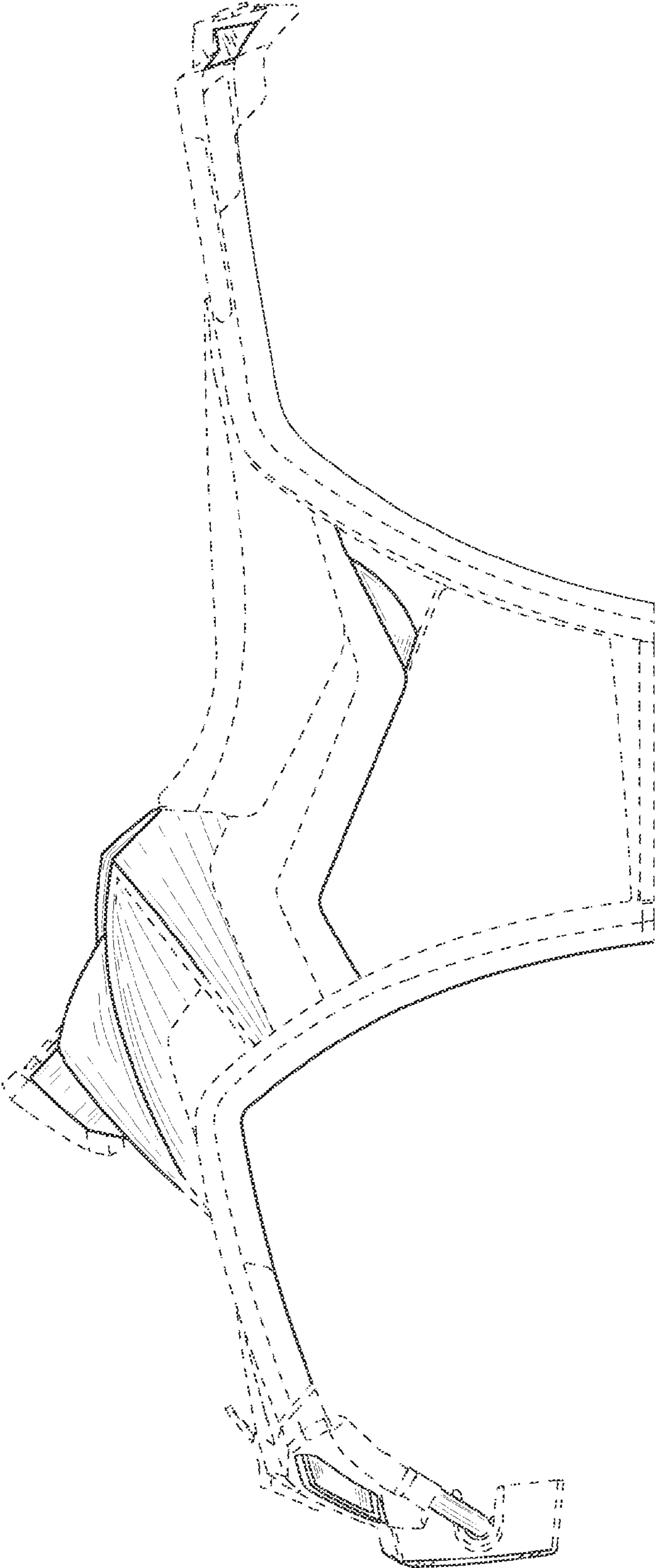

FIG. 5

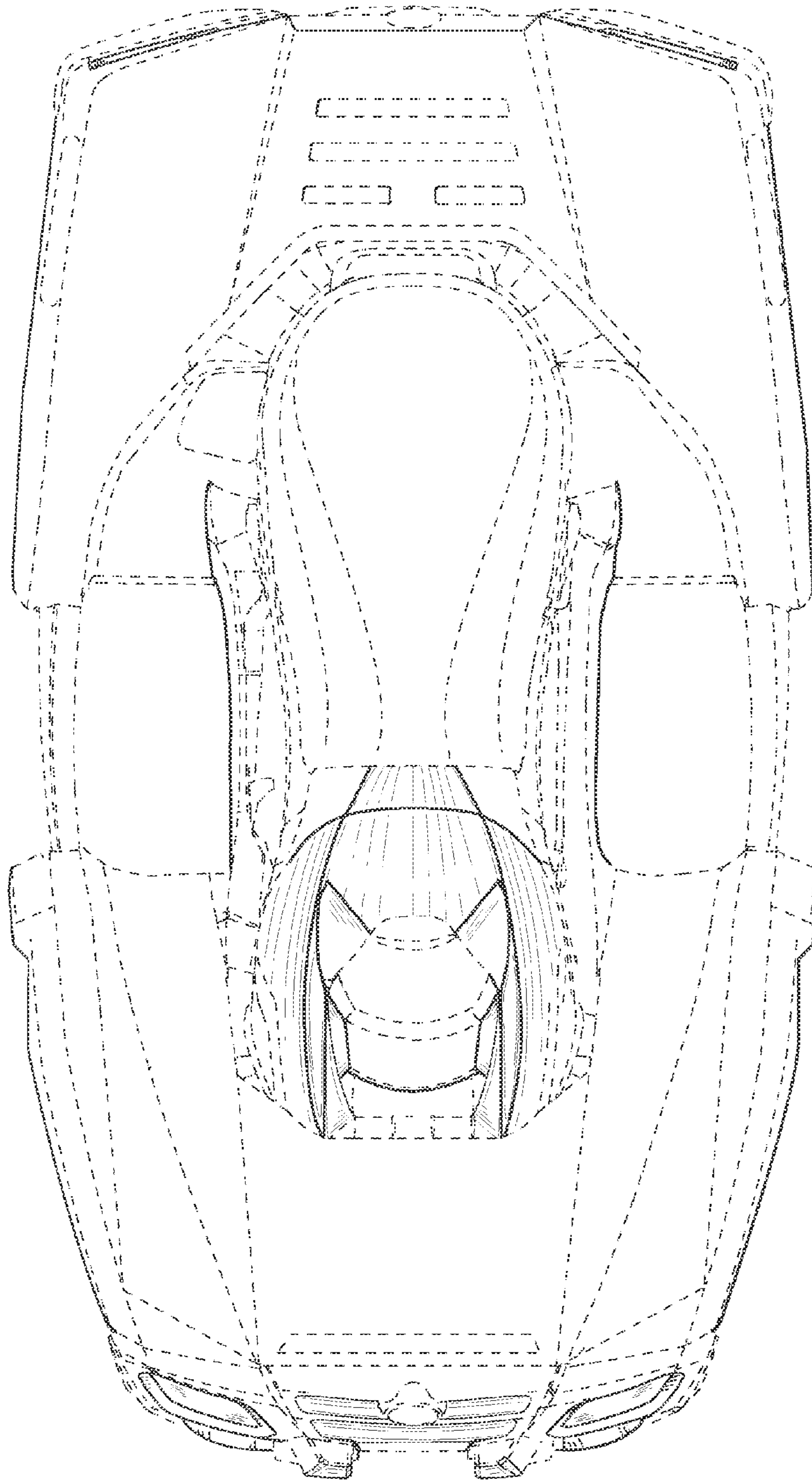

FIG. 6

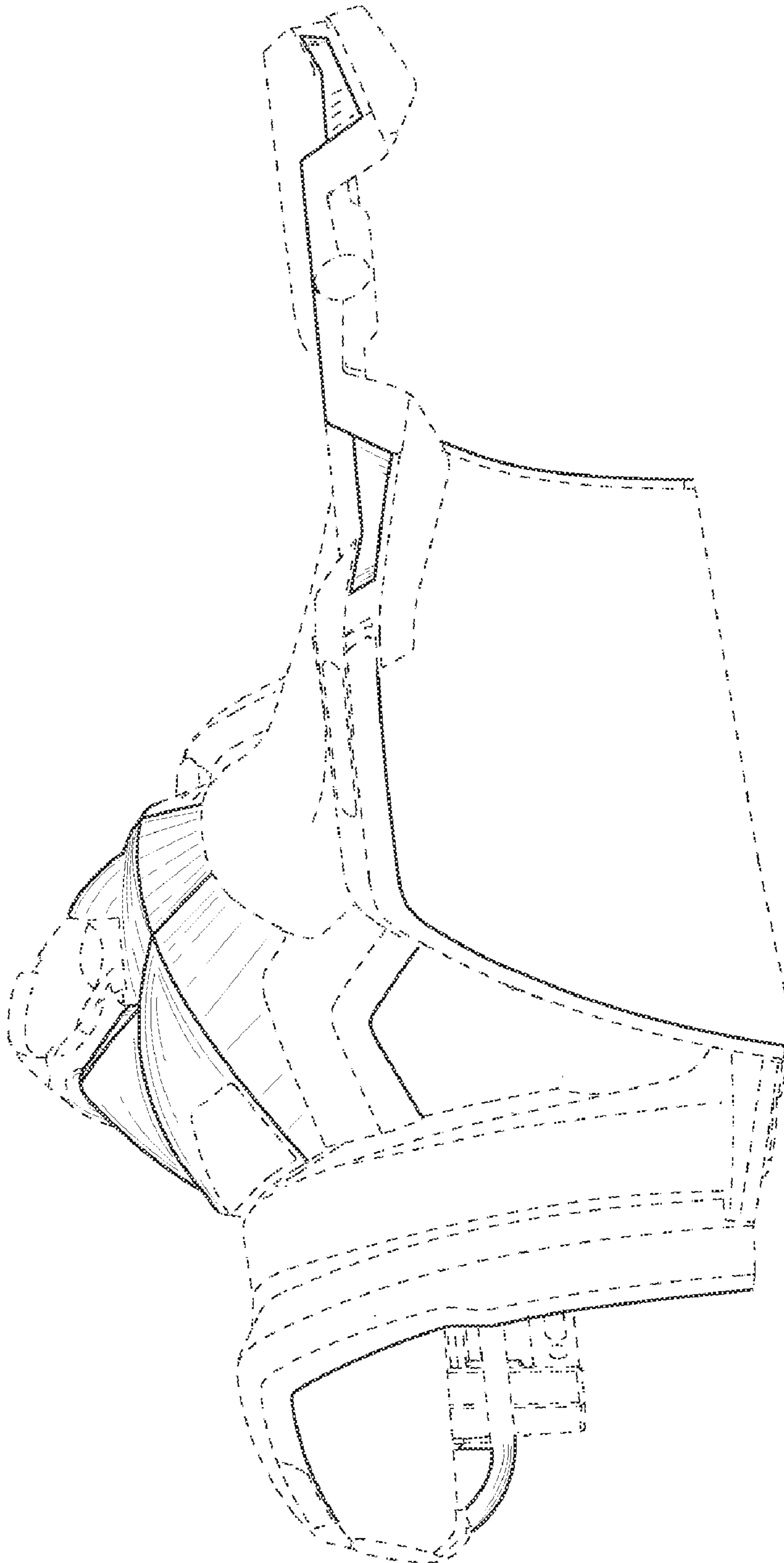

FIG. 7

UNITED STATES PATENT AND TRADEMARK OFFICE
CERTIFICATE OF CORRECTION

PATENT NO. : Des. 560,139 S
APPLICATION NO. : 29/236918
DATED : January 22, 2008
INVENTOR(S) : Jean-Philippe Crepeau

Page 1 of 9

It is certified that error appears in the above-identified patent and that said Letters Patent is hereby corrected as shown below:

The substitution of drawings attached hereto for those in the Issued Patent.

Please substitute the old drawings figures 1-7 with these new formal drawings figures 1-7 that are attached here.

Signed and Sealed this

Thirtieth Day of December, 2008

A handwritten signature in black ink that reads "Jon W. Dudas". The signature is written in a cursive style with a large, stylized initial "J".

JON W. DUDAS

Director of the United States Patent and Trademark Office

(12) **United States Design Patent** (10) **Patent No.:** **US D560,139 S**
 Crépeau (45) **Date of Patent:** ** *Jan. 22, 2008

(54) **ALL-TERRAIN VEHICLE BODY**

(73) **Inventor:** Jean-Philippe Crépeau, Bromont (CA)

(73) **Assignee:** Bombardier Recreational Products
 Inc., Valcourt (CA)

(* **Notice:** This patent is subject to a terminal disclaimer.

(** **Term:** 14 Years

(21) **Appl. No.:** 29/236,918

(22) **Filed:** Aug. 21, 2005

(51) **LOC (8) CL** 12-11

(52) **U.S. CL** D12/107

(58) **Field of Classification Search** 1212/3,
 112/80, 87, 107, 110, 109-171; 293/115,
 293/146, 142-144, 149, 102, 112; 180/225,
 180/229, 233, 311, 312, 315, 60.6

See application file for complete search history.

(56) **References Cited**

U.S. PATENT DOCUMENTS

- 3421,975 S * 72000 Fajada D12/107
- 3496,708 S * 92004 Wu D12/107
- 3520,912 S * 92006 Knight et al D12/107

* cited by examiner

Primary Examiner—Cathron Brooks

Assistant Examiner—Linda Brooks

(74) *Attorney, Agent, or Firm*—Oliet, Hoskin & Farncourt
 LLP

(57) **CLAIM**

The ornamental design for an all-terrain vehicle body, as shown and described.

DESCRIPTION

FIG. 1 is a perspective view from the front and left side of an all-terrain vehicle body according to our design.

FIG. 2 is a front elevational view thereof.

FIG. 3 is a rear elevational view thereof.

FIG. 4 is a right side elevational view thereof.

FIG. 5 is a left side elevational view thereof.

FIG. 6 is a top plan view thereof, and.

FIG. 7 is a perspective view from the rear and left side thereof.

The broken lines immediately adjacent the shaded areas represent the bounds of the claimed design; while all other broken lines are directed to environmental structure and are for illustrative purposes only; all of the broken lines form no part of the claimed design.

1 Claim, 7 Drawing Sheets

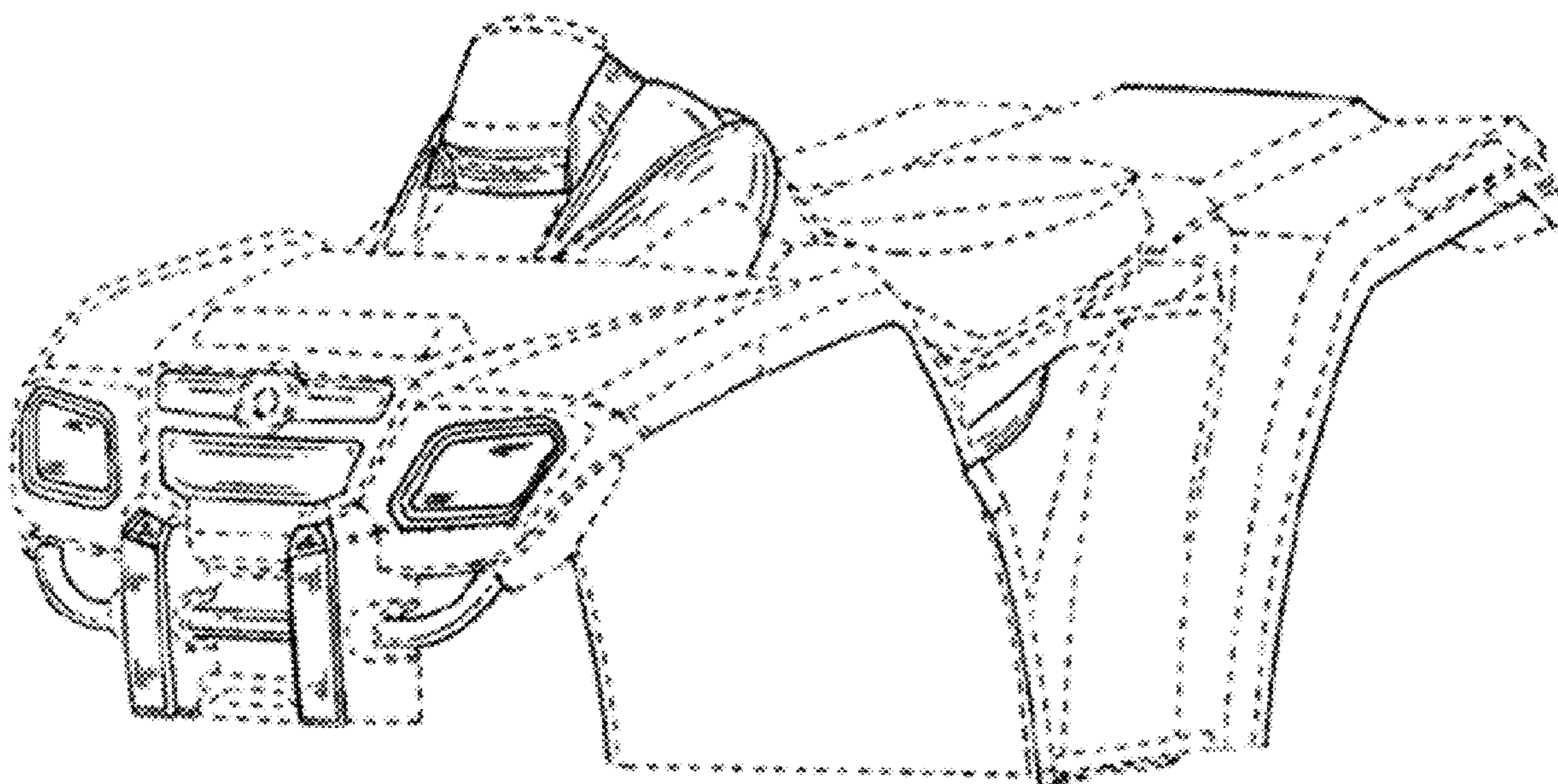

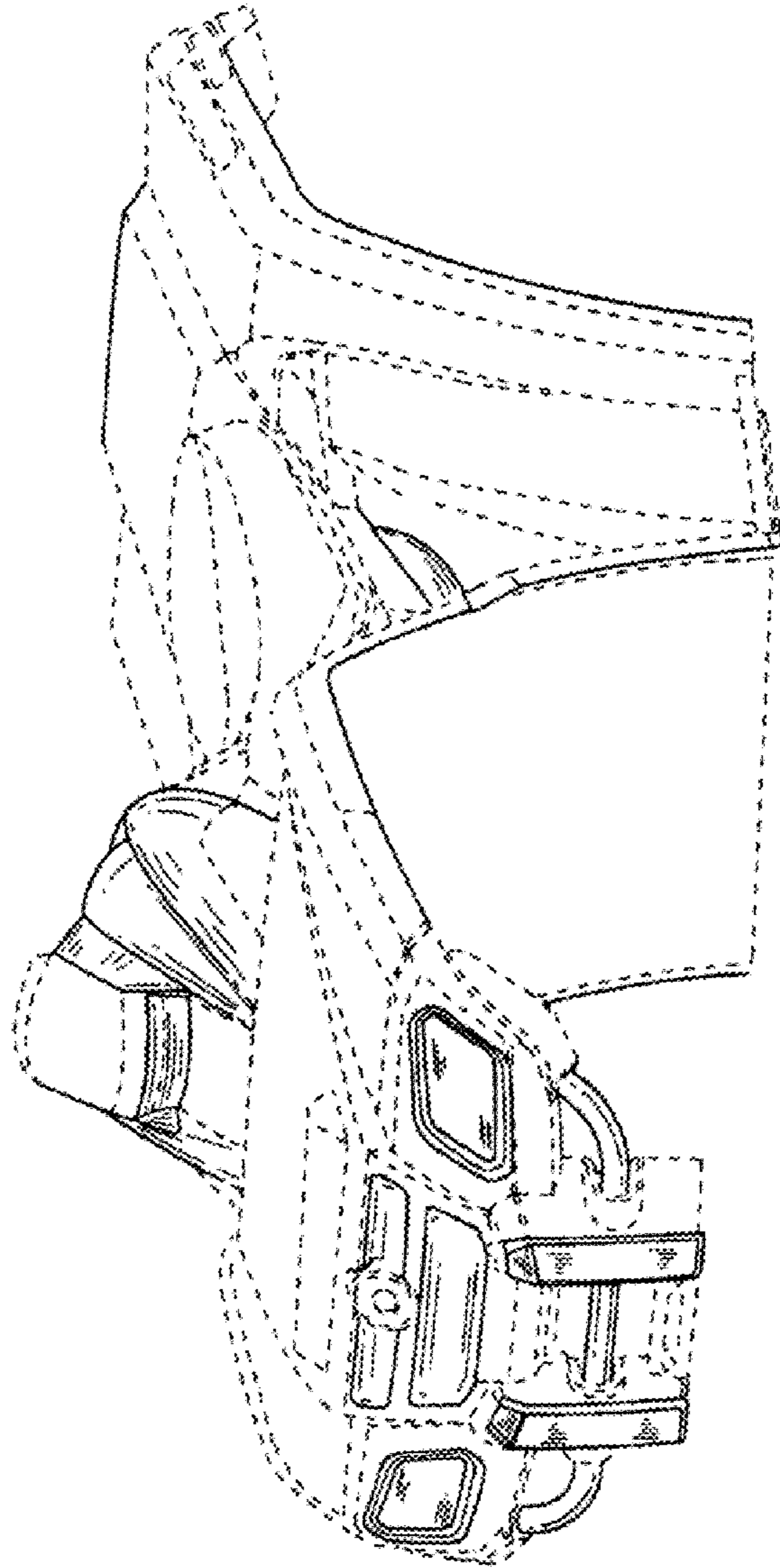

FIG. 1

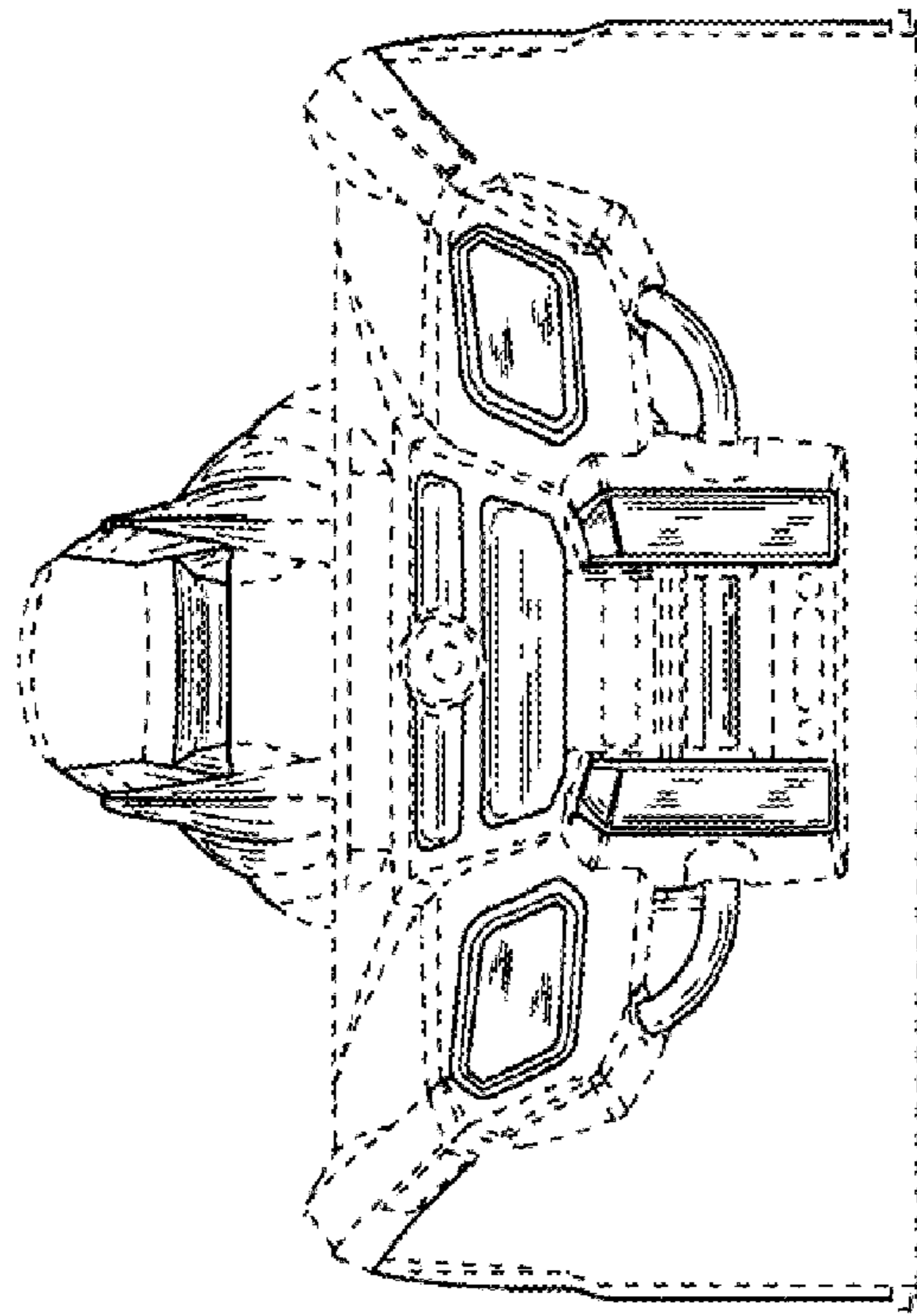

FIG. 2

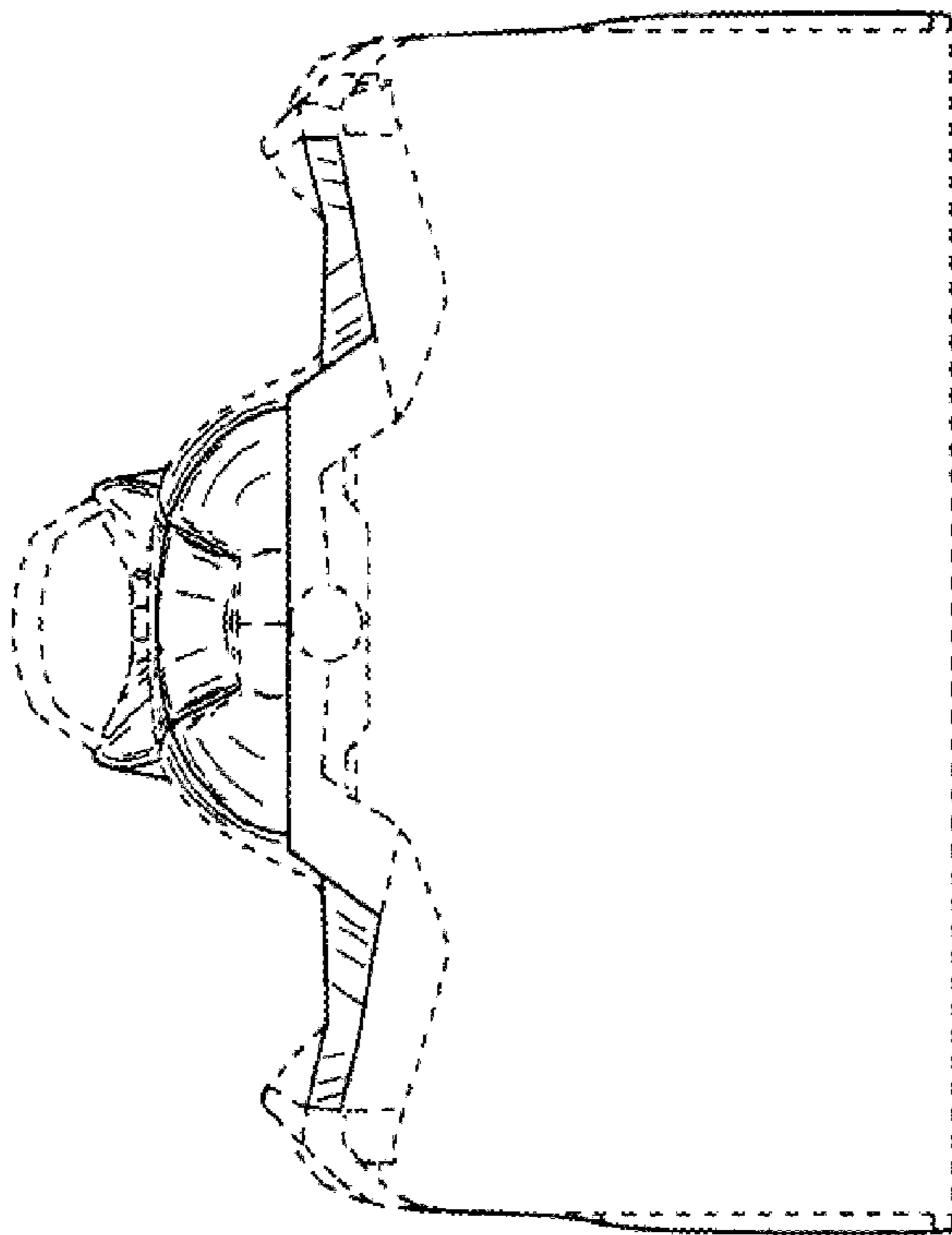

FIG. 3

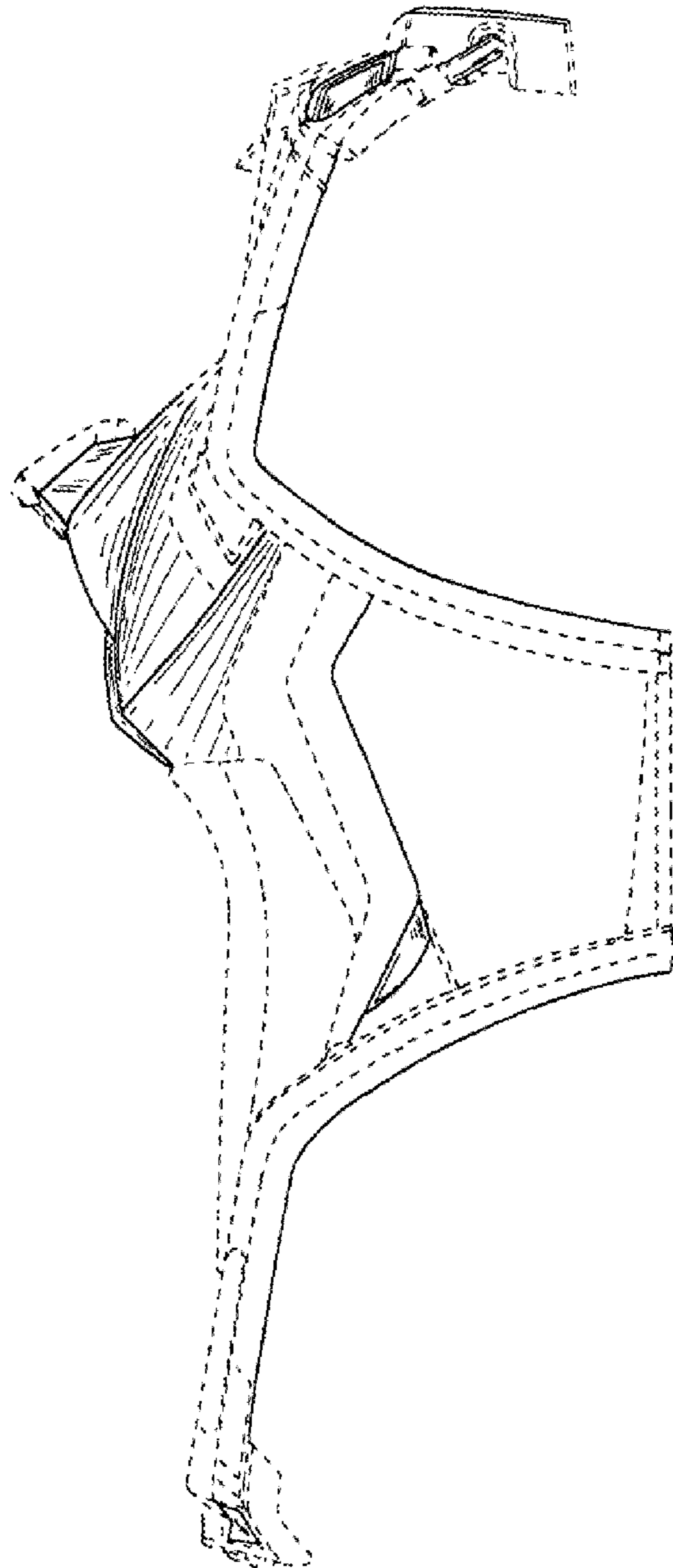

FIG. 4

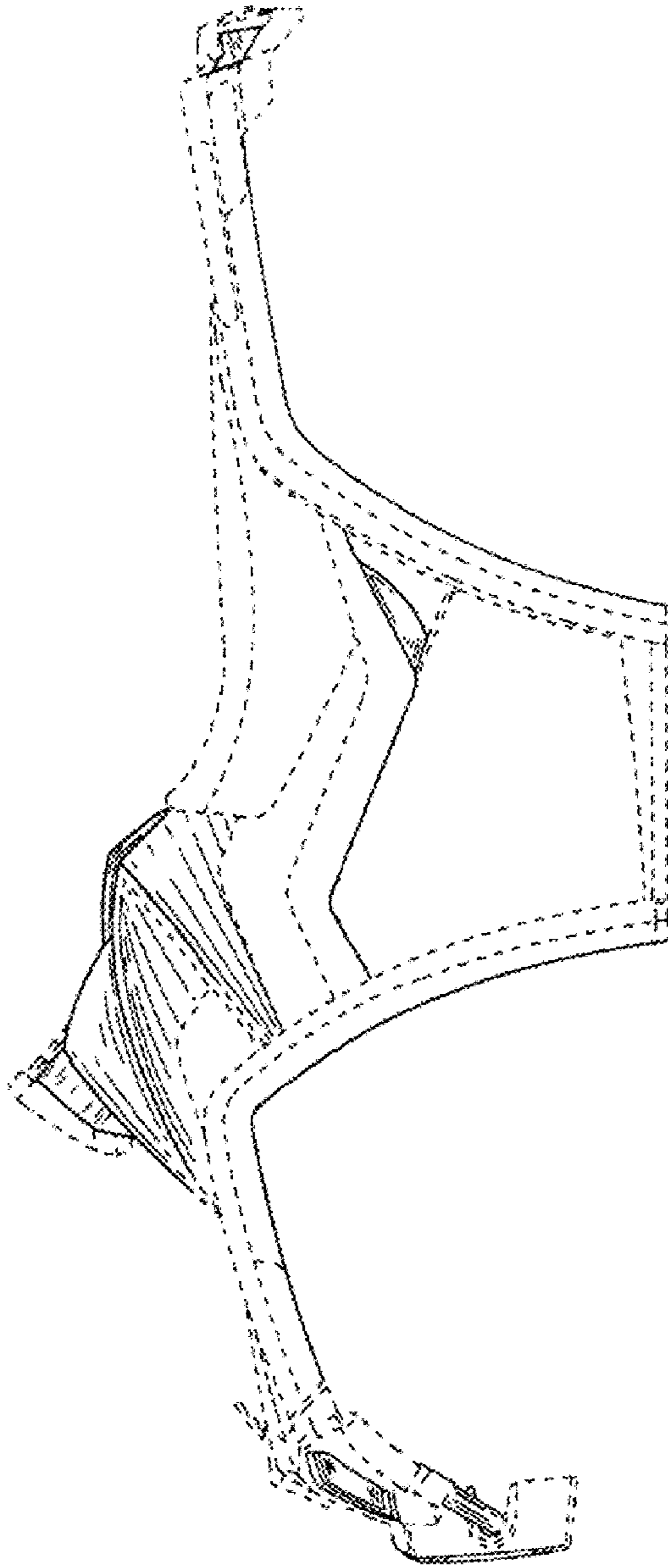

FIG. 5

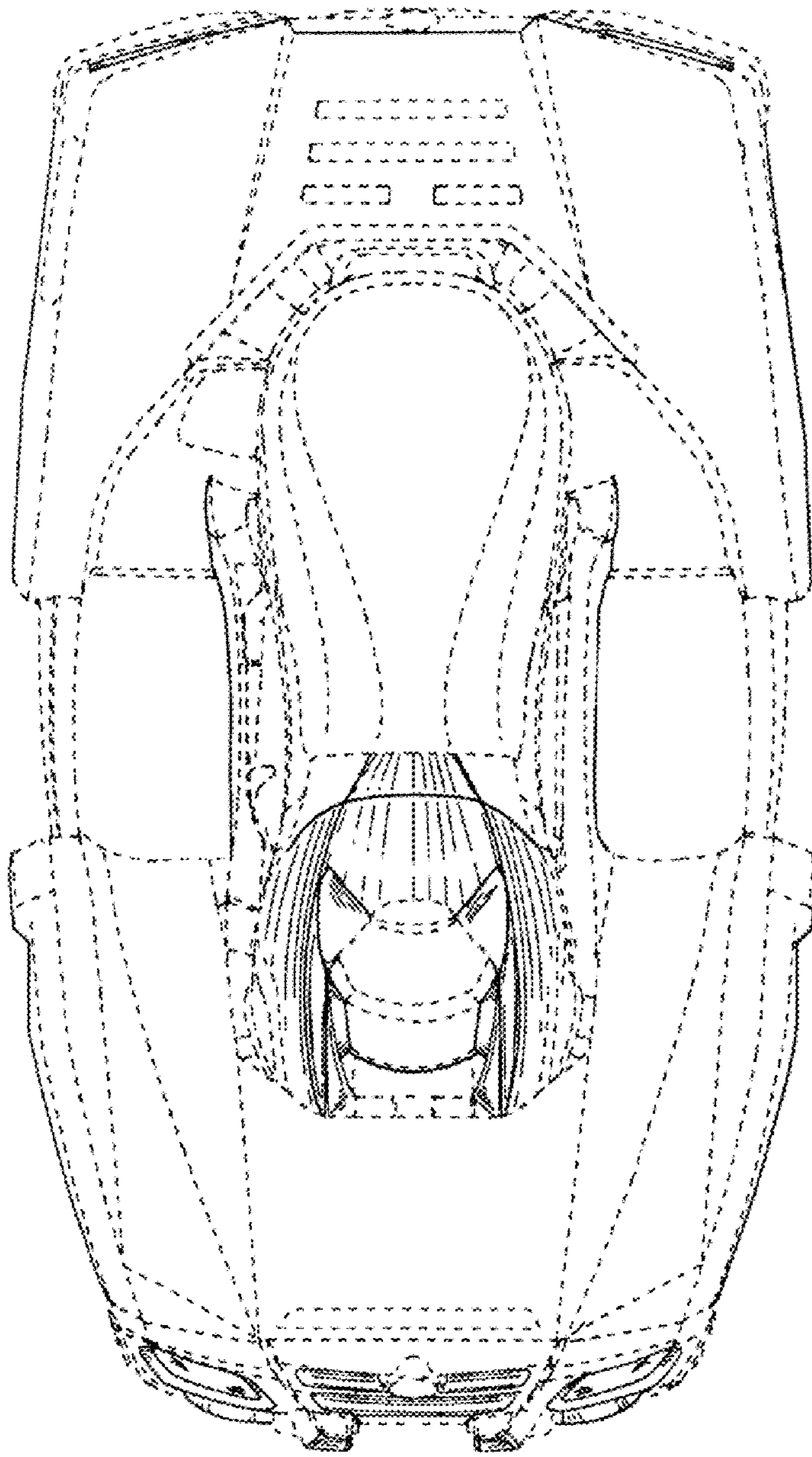

FIG. 6

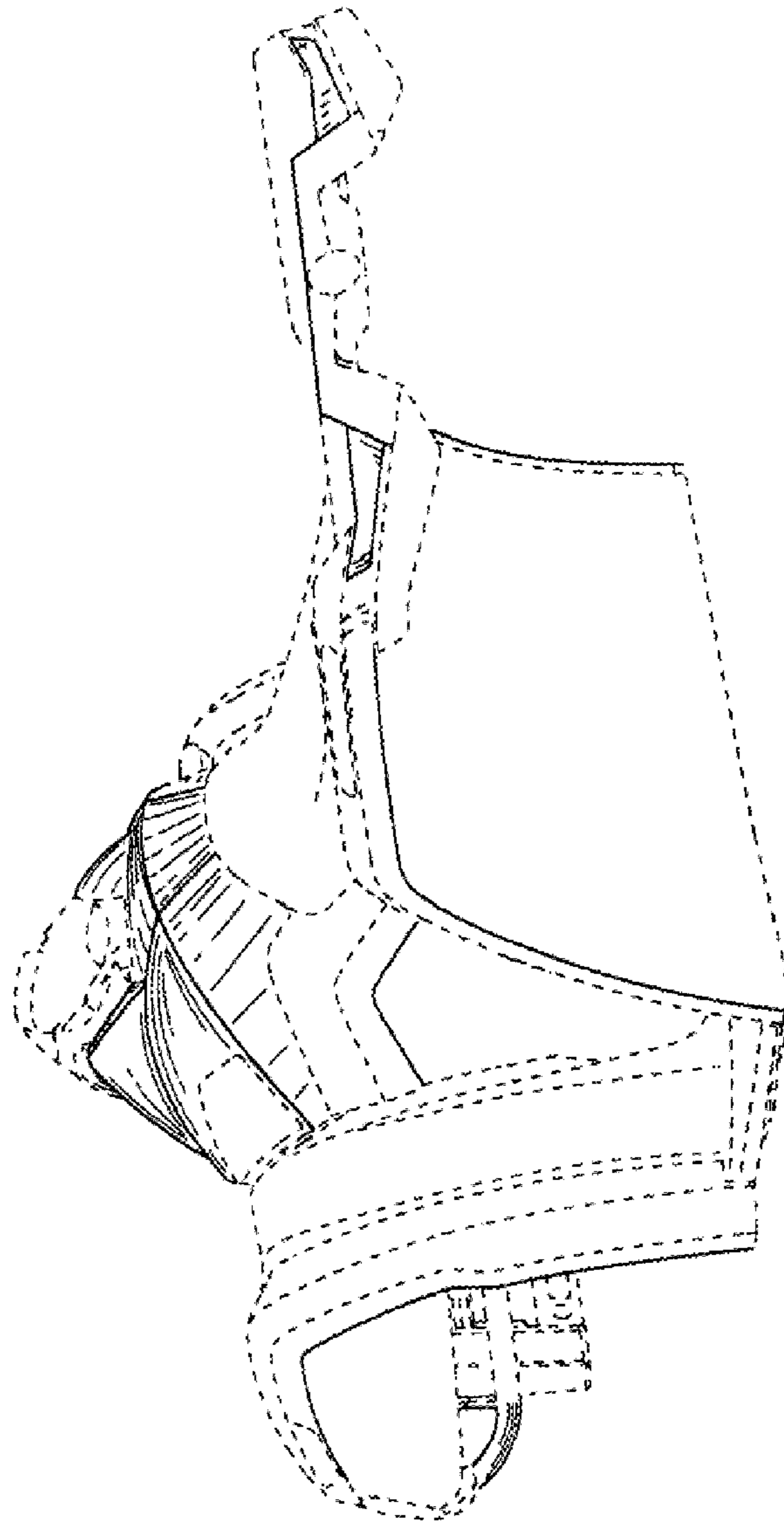

FIG. 7