



US00D559786S

(12) **United States Design Patent**  
**Kudo et al.**

(10) **Patent No.:** **US D559,786 S**  
(45) **Date of Patent:** **\*\* Jan. 15, 2008**

(54) **ELECTRICAL CONNECTOR HOUSING**

(75) Inventors: **Tsutomu Kudo**, Ibaragi (JP); **Mirai Maebashi**, Kanagawa (JP)

(73) Assignee: **Tyco Electronics AMP K.K.**, Kanagawa-Ken (JP)

(\*\*) Term: **14 Years**

(21) Appl. No.: **29/277,443**

(22) Filed: **Feb. 26, 2007**

(30) **Foreign Application Priority Data**

Feb. 23, 2007 (JP) ..... 2007-004500

(51) **LOC (8) Cl.** ..... **13-03**

(52) **U.S. Cl.** ..... **D13/147**

(58) **Field of Classification Search** ..... D13/133,  
D13/146-147, 154, 184, 199; 439/350-354,  
439/357, 594-595, 597, 660, 680, 682, 692  
See application file for complete search history.

(56) **References Cited**

**U.S. PATENT DOCUMENTS**

D311,380 S	*	10/1990	Kameyama et al.	.....	D13/147
D311,517 S	*	10/1990	Kameyama et al.	.....	D13/147
D316,703 S	*	5/1991	Eto et al.	.....	D13/147
D324,671 S	*	3/1992	Kawashima et al.	.....	D13/147
D332,774 S	*	1/1993	Watanabe et al.	.....	D13/147
5,628,648 A	*	5/1997	Higgins et al.	.....	439/489
D494,141 S	*	8/2004	Spink, Jr.	.....	D13/147
D524,751 S	*	7/2006	Lee et al.	.....	D13/147

**FOREIGN PATENT DOCUMENTS**

JP	1074718	6/2000
JP	1186128	9/2003
JP	1230158	2/2005

JP	1230292	2/2005
JP	1237434	4/2005
JP	1237897	4/2005
JP	1237898	4/2005
JP	1237899	4/2005
JP	1277732	7/2006
JP	1278011	7/2006
JP	1278012	7/2006

**OTHER PUBLICATIONS**

Tyco Electronics, Dynamic Series Connectors, catalog 124986, revised Nov. 2006, 4 pages.

Tyco Electronics, Dynamic Series Connectors, Catalog 124975, Revised Jul. 2006.

Japanese Newspaper, No. 060706\_01, Published Jul. 6, 2006.

\* cited by examiner

*Primary Examiner*—Daniel Bui

(74) *Attorney, Agent, or Firm*—Barley Snyder LLC

(57) **CLAIM**

The ornamental design for an electrical connector housing, as shown and described.

**DESCRIPTION**

FIG. 1 is a front view of an electrical connector housing showing our new design;

FIG. 2 is a top view thereof;

FIG. 3 is a bottom view thereof;

FIG. 4 is a right side view thereof;

FIG. 5 is a rear view thereof;

FIG. 6 is a top, front and left side perspective view thereof on an enlarged scale; and,

FIG. 7 is a bottom, rear and right side perspective view thereof.

**1 Claim, 7 Drawing Sheets**

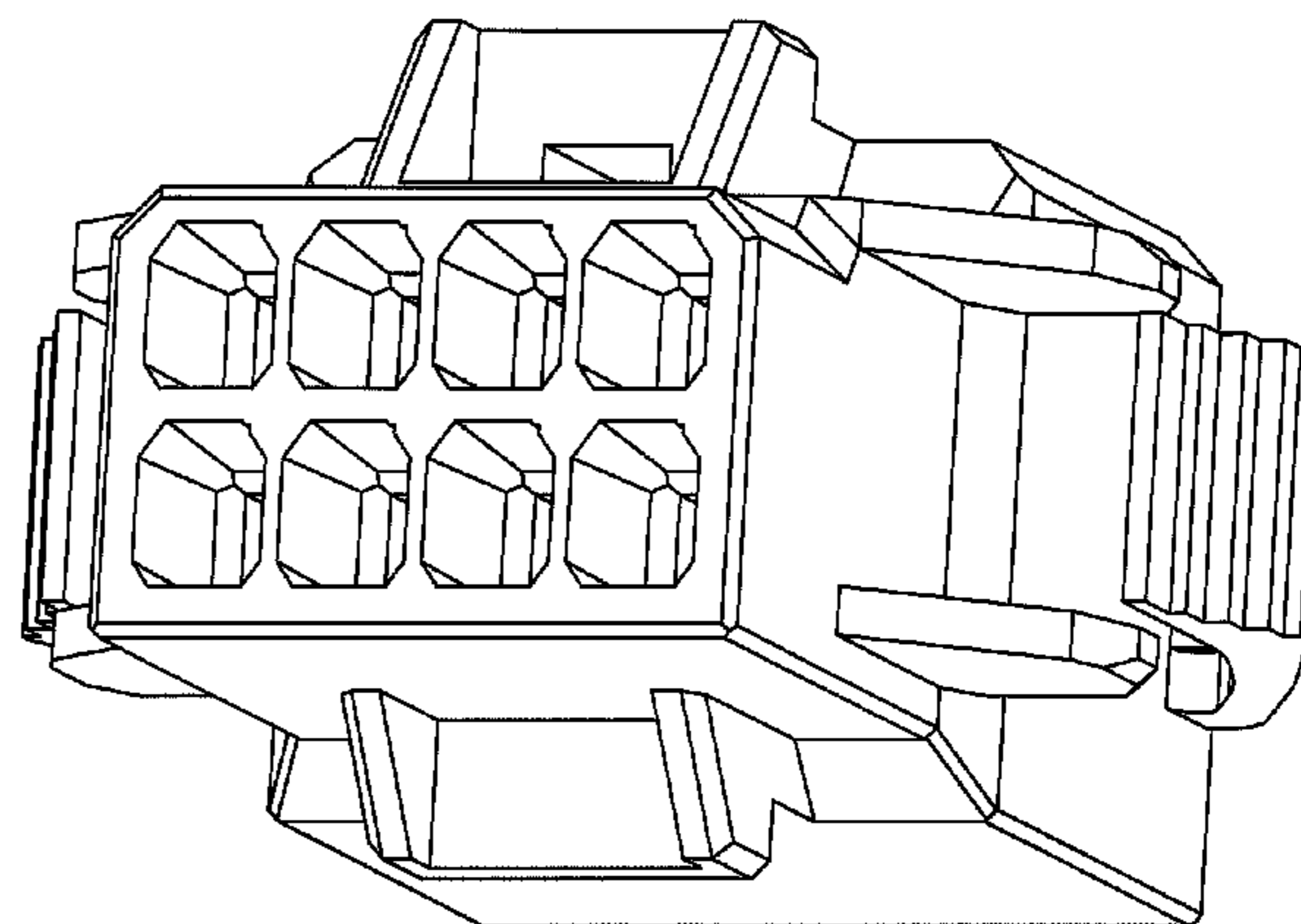
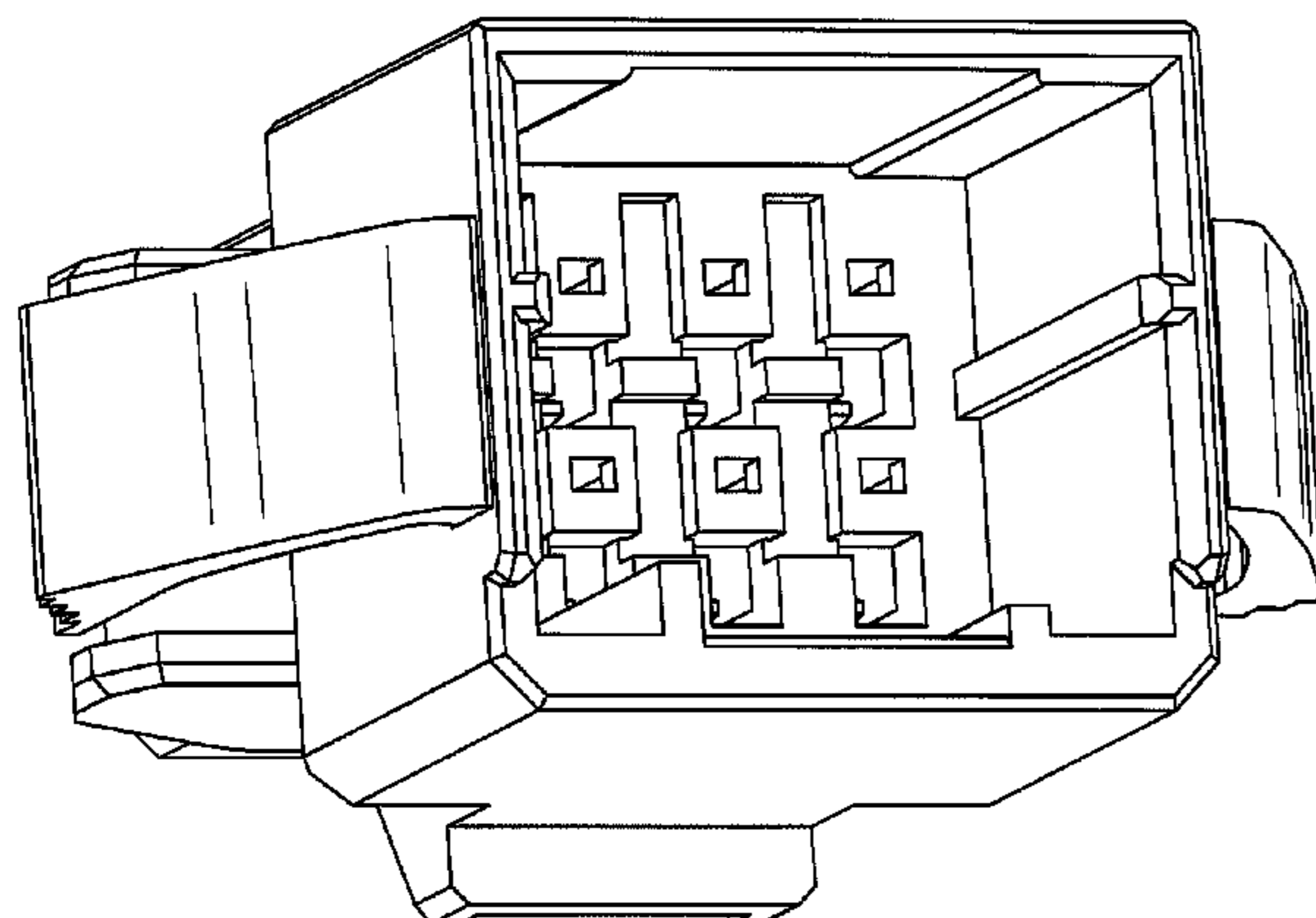

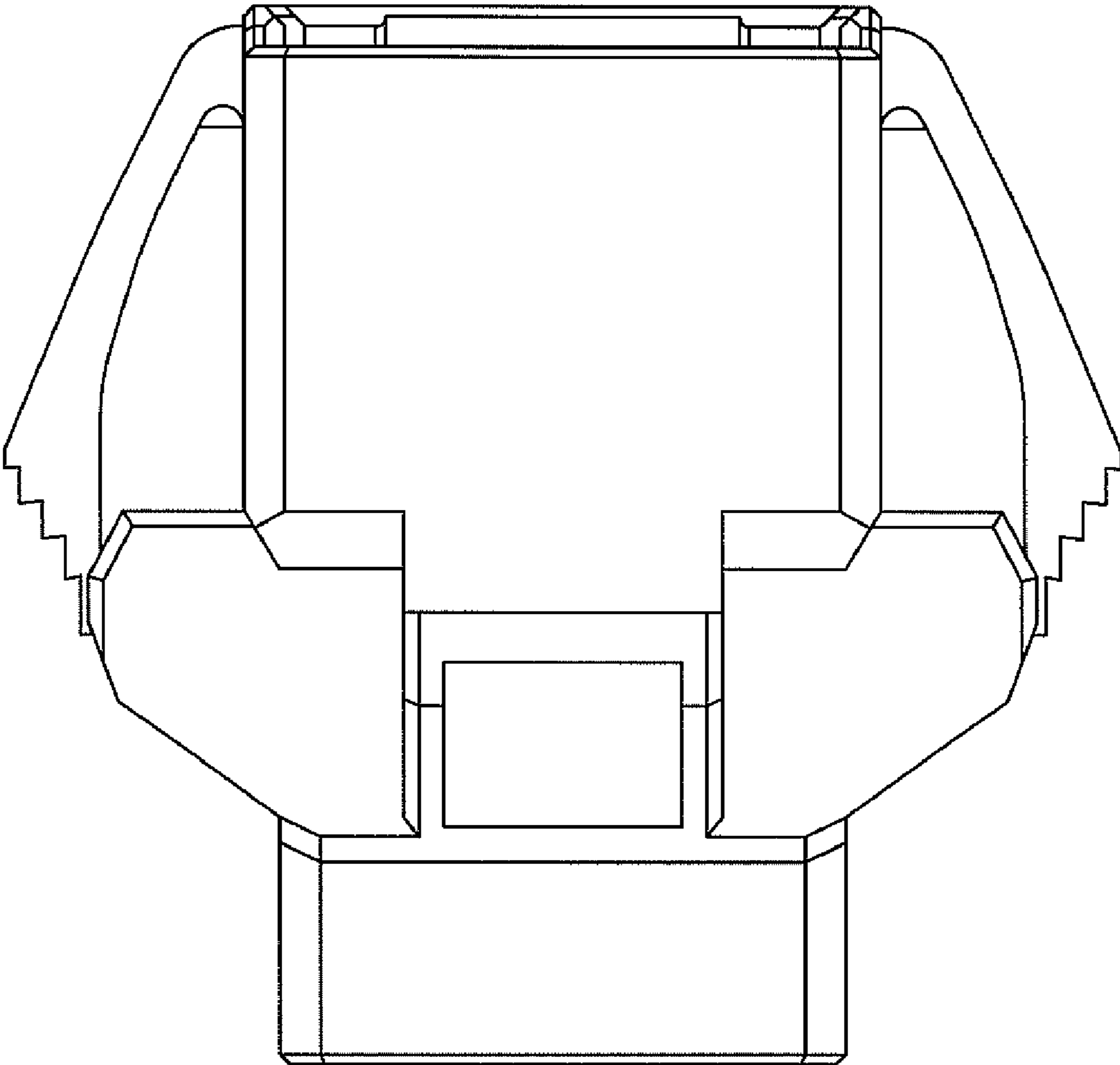

FIG.1

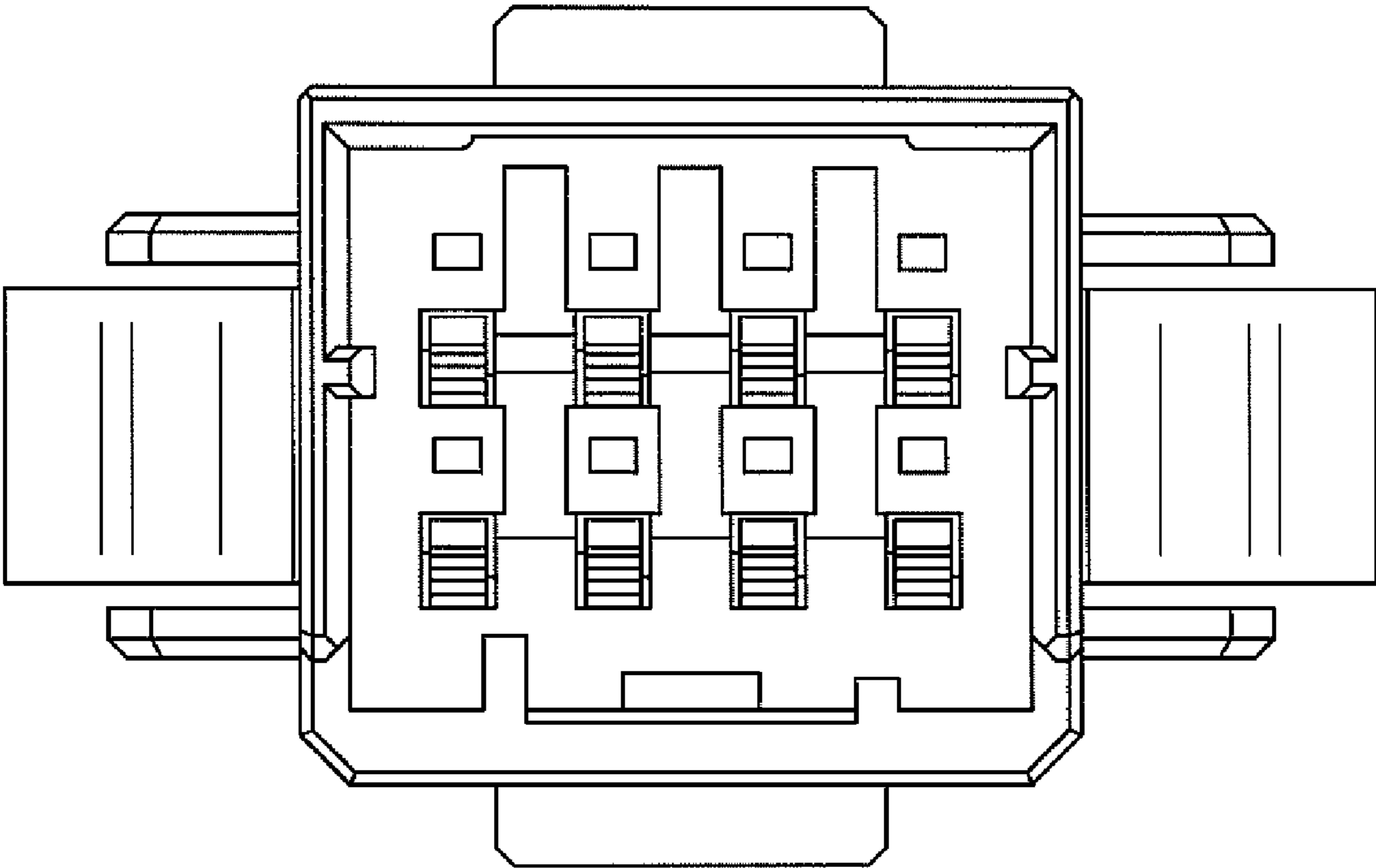

FIG.2

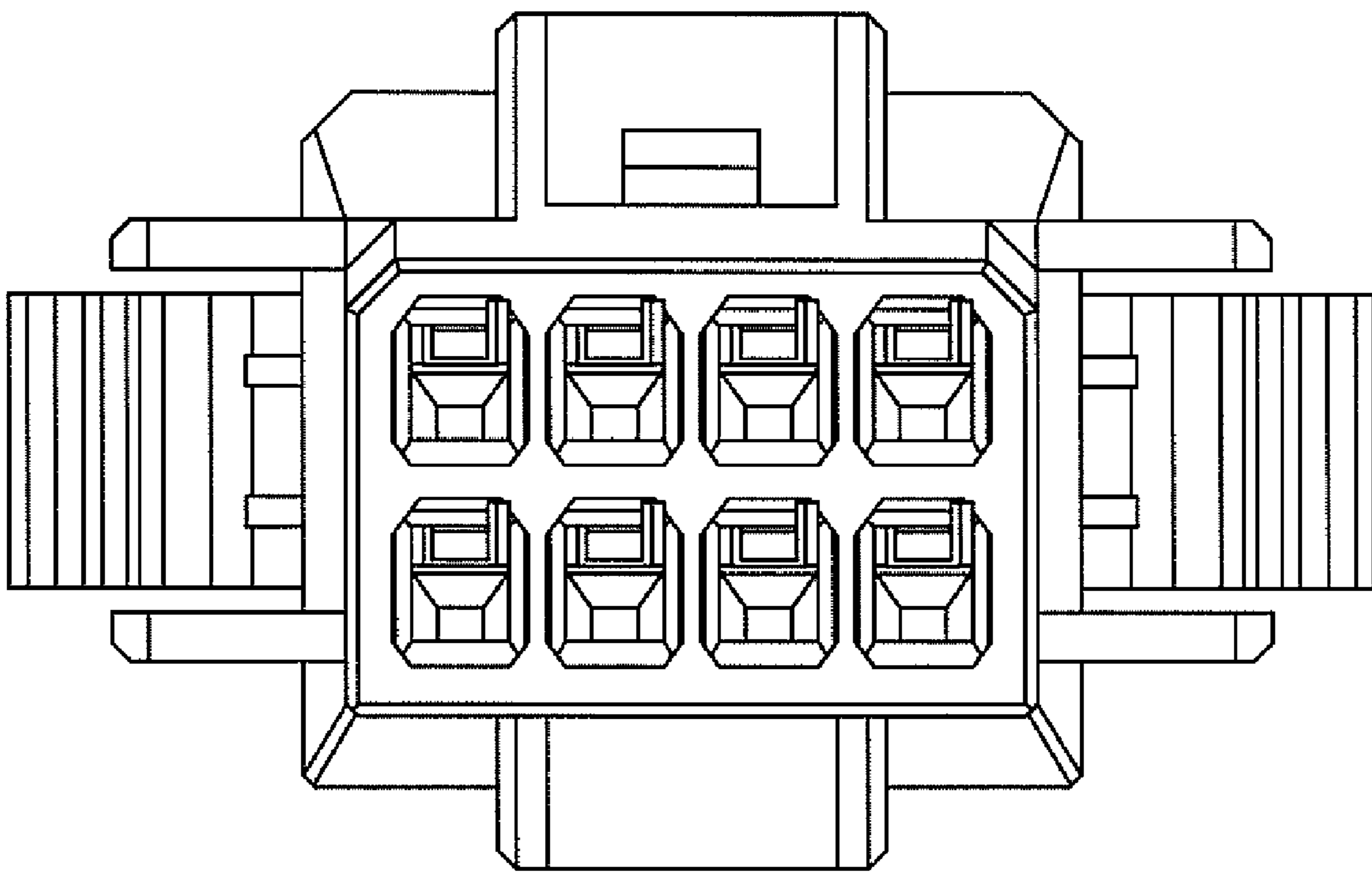

FIG.3

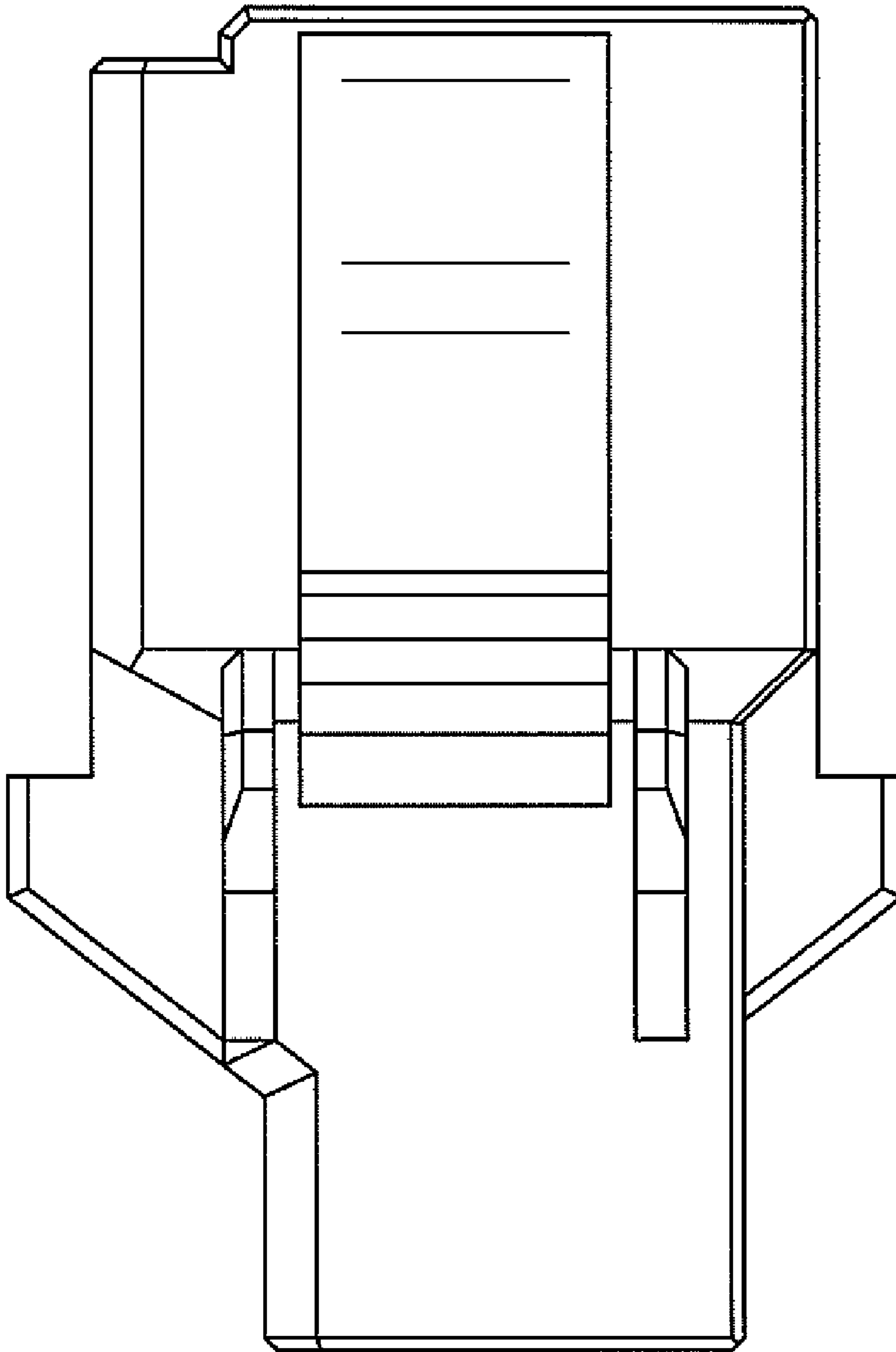

FIG. 4

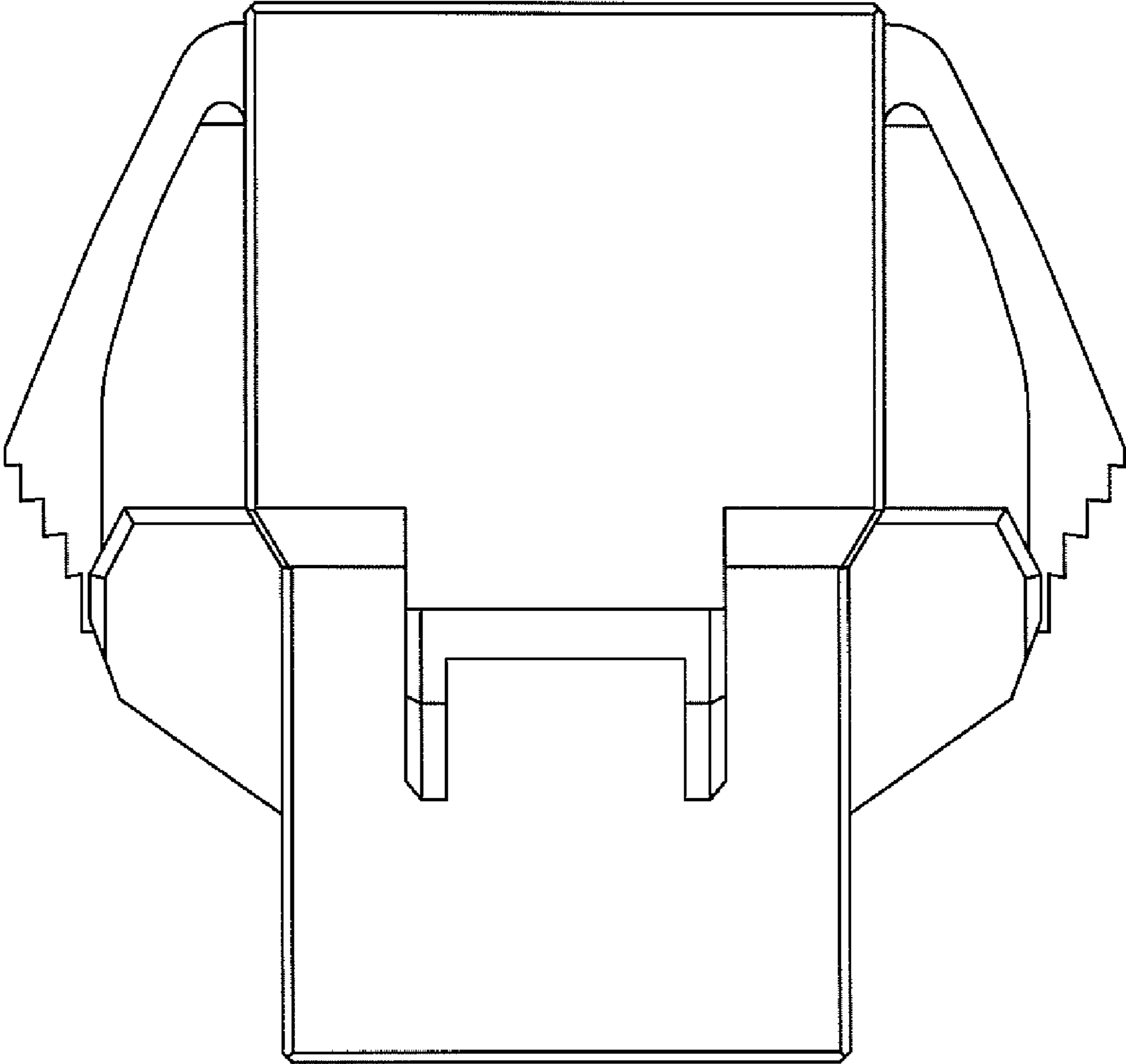

FIG.5

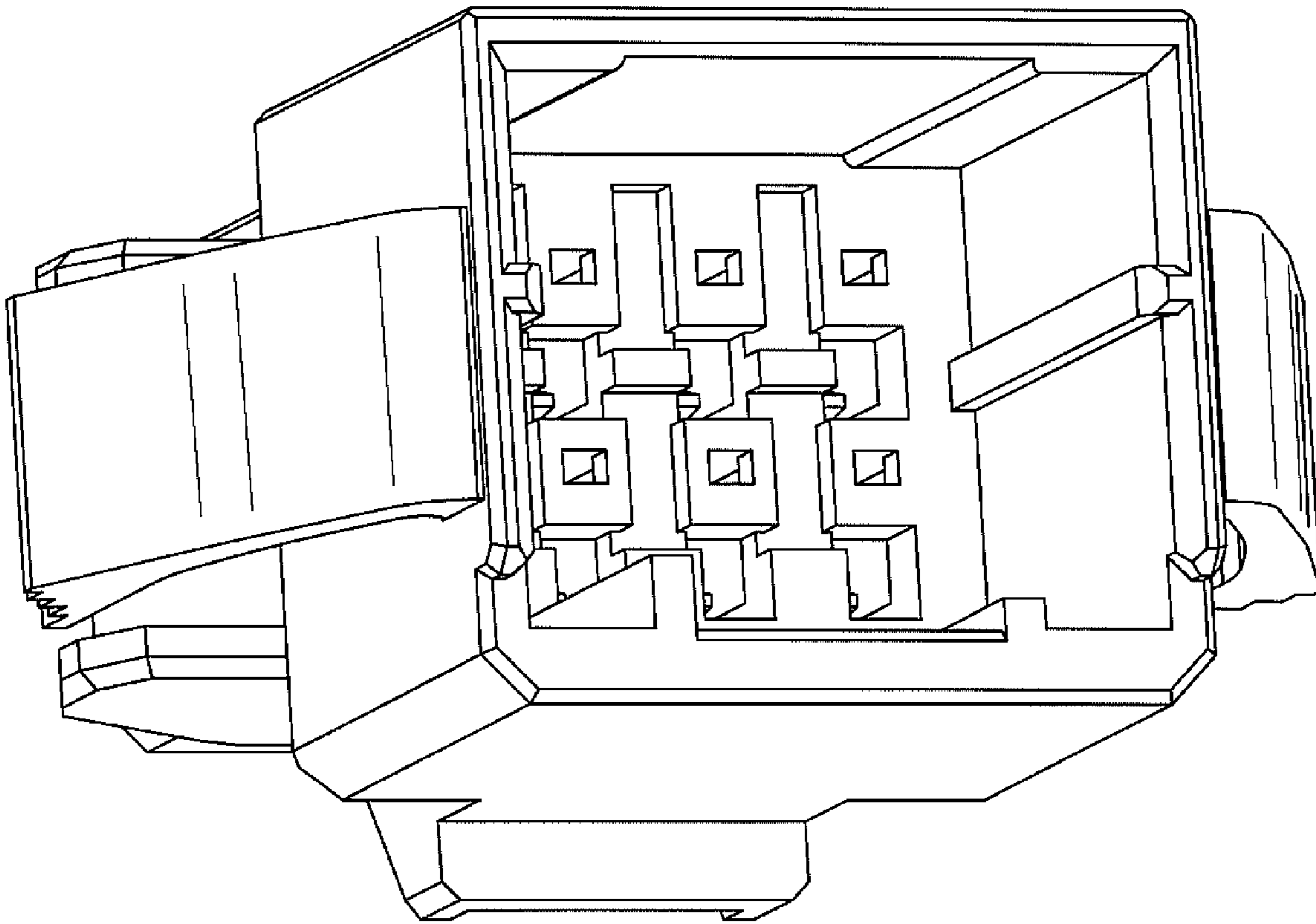

FIG.6

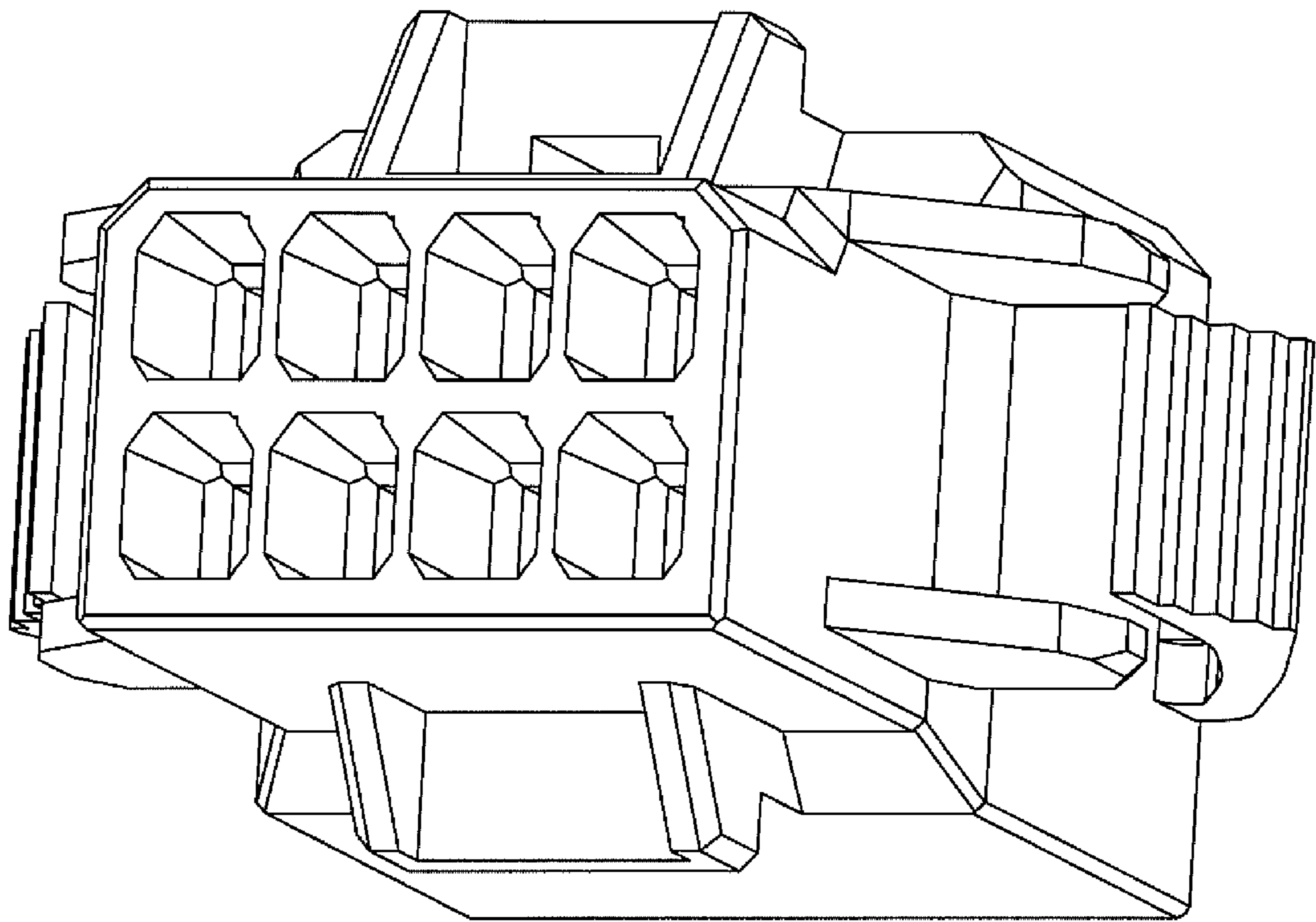

FIG. 7