



US00D559416S

(12) **United States Design Patent** (10) **Patent No.:** **US D559,416 S**
Schiavone et al. (45) **Date of Patent:** **** Jan. 8, 2008**

(54) **VEHICLE HEADLIGHT**

(74) *Attorney, Agent, or Firm*—Damian Porcari

(75) Inventors: **Patrick Schiavone**, Bloomfield, MI (US); **James Grake**, Royal Oak, MI (US); **Curt Aumiller**, Dearborn, MI (US); **Laurens Van Den Acker**, Ann Arbor, MI (US)

(57) **CLAIM**

The ornamental design for a vehicle headlight, as shown and described.

(73) Assignee: **Ford Global Technologies, LLC**, Dearborn, MI (US)

DESCRIPTION

(**) Term: **14 Years**

FIG. 1 is a frontal perspective view of a left vehicle headlight attached to a vehicle, no part of the vehicle is claimed;

(21) Appl. No.: **29/243,473**

FIG. 2 is a perspective view of the left vehicle headlight;

(22) Filed: **Nov. 22, 2005**

FIG. 3 is a front elevational view of the left vehicle headlight;

(51) **LOC (8) Cl.** **26-06**

FIG. 4 is a top plan view of the left vehicle headlight;

(52) **U.S. Cl.** **D26/28**

FIG. 5 is a bottom plan view of the left vehicle headlight;

(58) **Field of Classification Search** D26/28–36;
362/459–468, 475–478, 485–487
See application file for complete search history.

FIG. 6 is a left side elevational view of the left vehicle headlight;

(56) **References Cited**

FIG. 7 is a right side elevational view of the left vehicle headlight;

U.S. PATENT DOCUMENTS

FIG. 8 is a front elevational view of a vehicle headlight illustrated in FIGS. 1–7, showing a right vehicle headlight, with the vehicle shown in broken lines and forming no part of the claimed design;

D535,763 S *	1/2007	Pfeiffer	D26/28
D536,113 S *	1/2007	Pfeiffer	D26/28
D537,180 S *	2/2007	Hsu	D26/28
D540,482 S *	4/2007	Miwa et al.	D26/28
D541,445 S *	4/2007	Lin	D26/28
D546,486 S *	7/2007	Sinkwitz	D26/28

FIG. 9 is a perspective view of the right vehicle headlight;

OTHER PUBLICATIONS

New York Auto Show, *2005 Ford Explorer*, Mar. 23, 2005.
North American International Auto Show (Detroit), *2005 Ford Escape*, Jan. 9, 2004.
North American International Auto Show (Detroit), *2004 Ford Expedition*, Jan. 9, 2003.
Sao Paulo Auto Show, *2005 EcoSport*, Oct. 10, 2004.

FIG. 10 is a front elevational view of the right vehicle headlight;

* cited by examiner

FIG. 11 is a top plan view of the right vehicle headlight;

FIG. 12 is a bottom plan view of the right vehicle headlight;

FIG. 13 is a right side elevational view of the right vehicle headlight; and,

Primary Examiner—Marcus A. Jackson

FIG. 14 is a left side elevational view of the right vehicle headlight.

The phantom lines are not a part of the claimed invention.

1 Claim, 14 Drawing Sheets

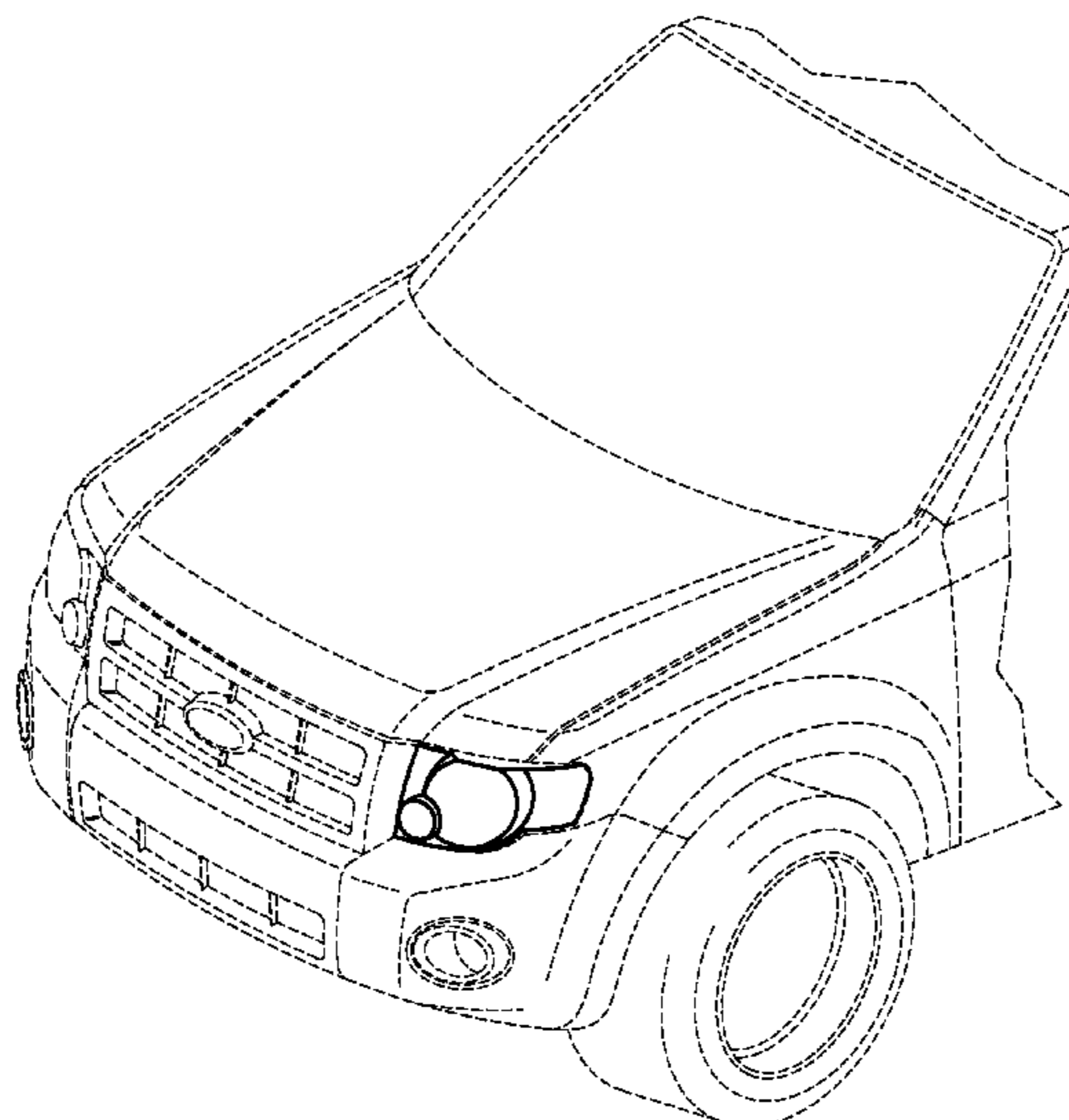

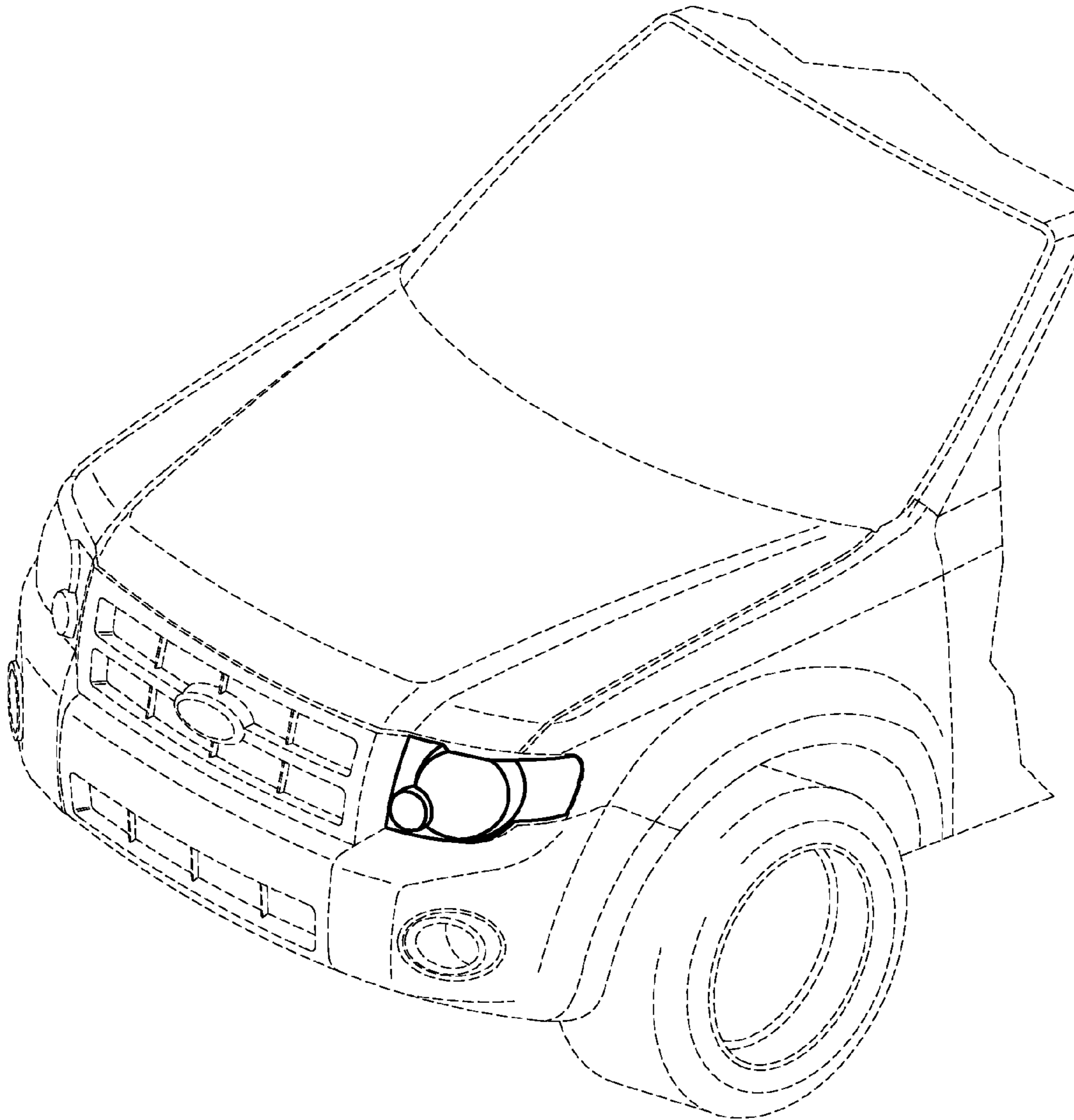

FIG - 1

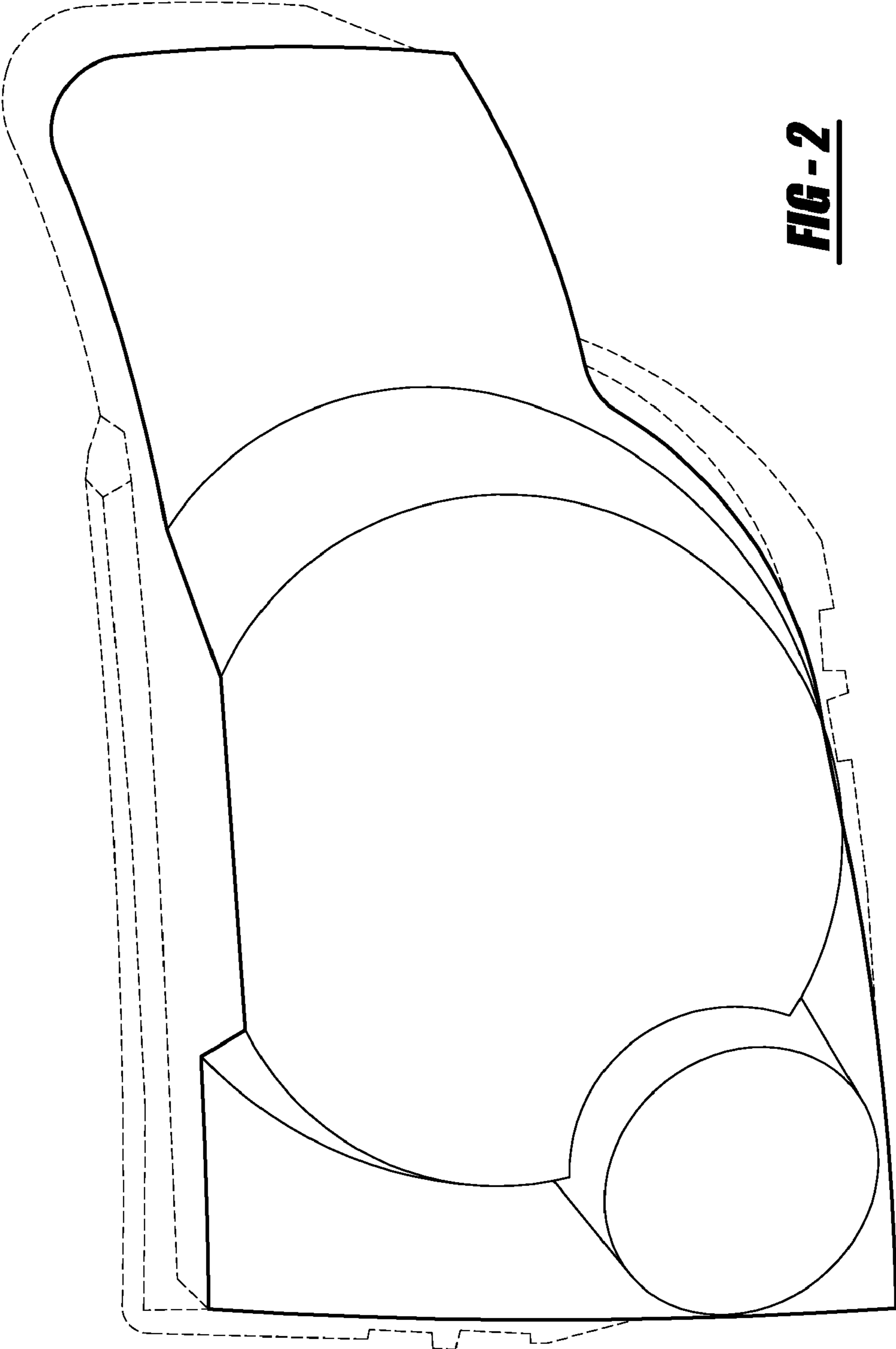
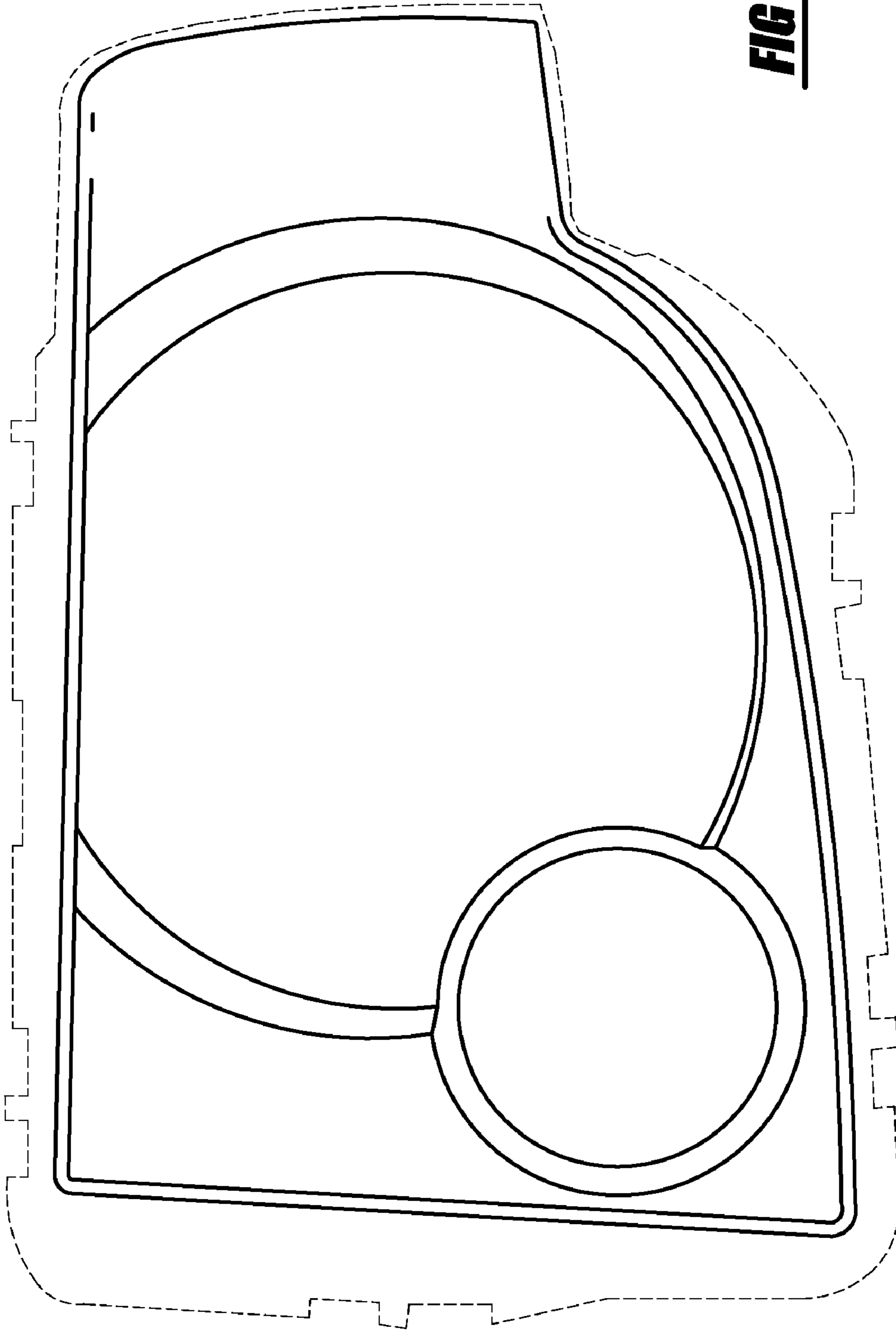

FIG - 2

FIG - 3



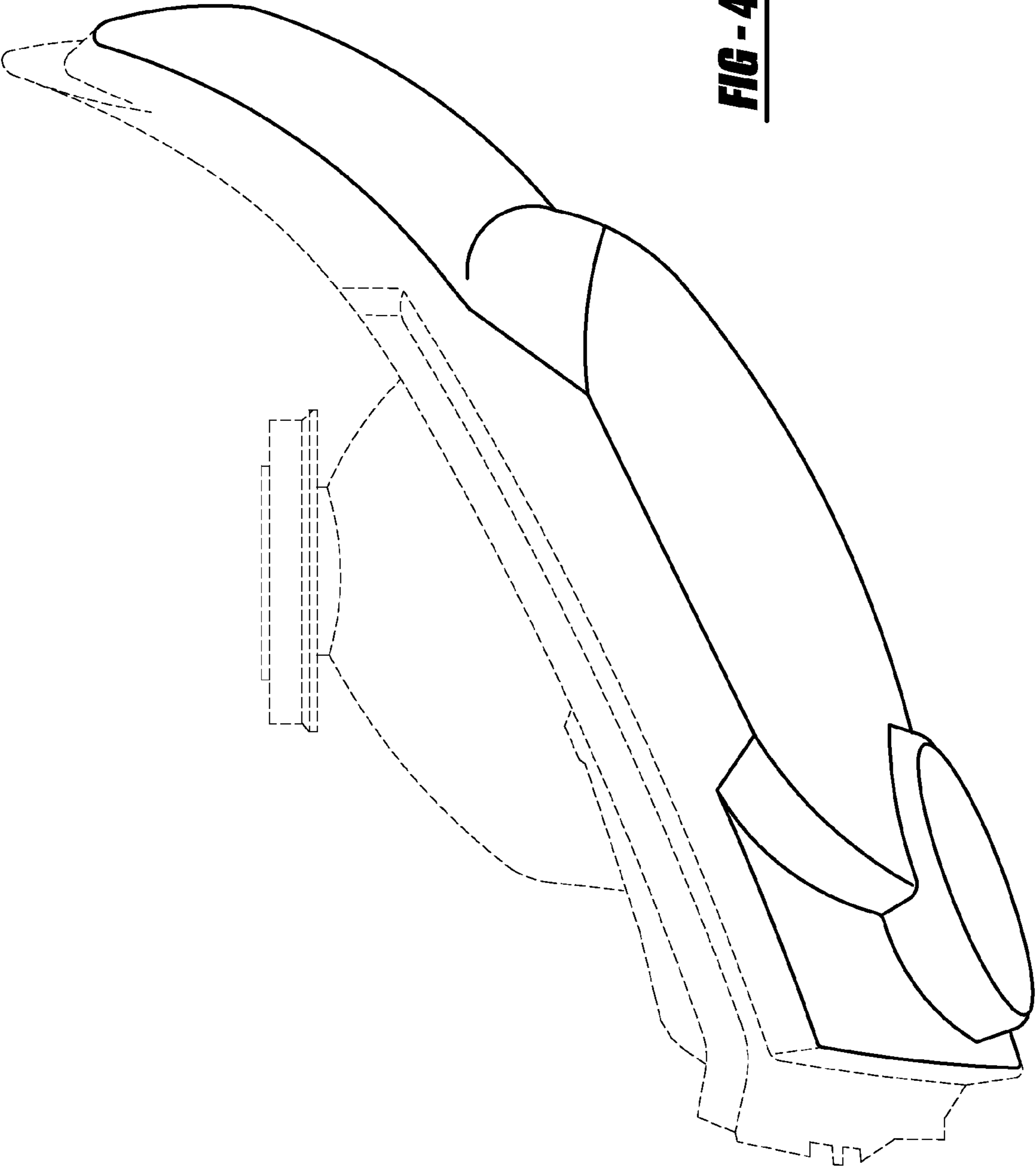

FIG - 4

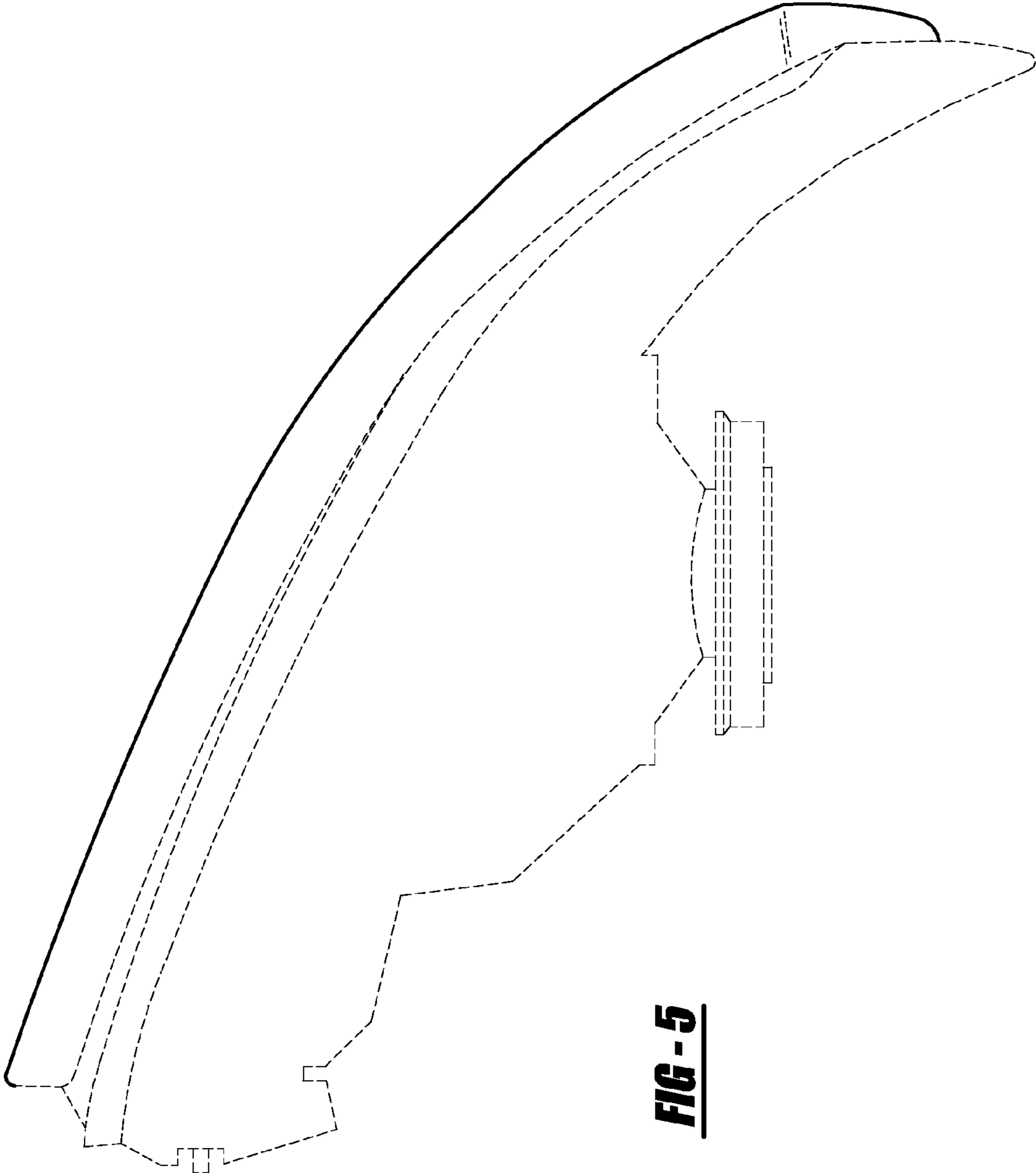

FIG - 5

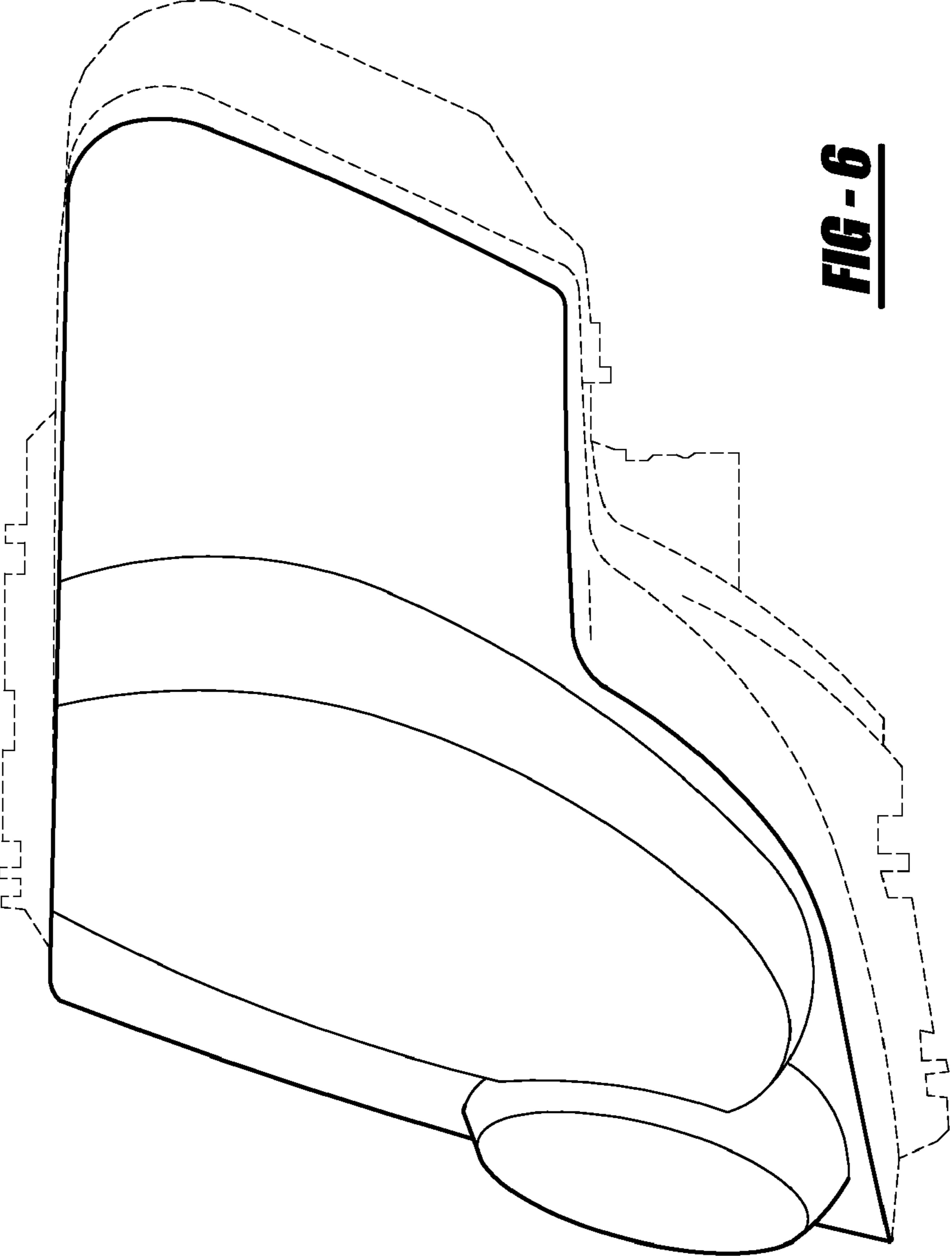

FIG - 6

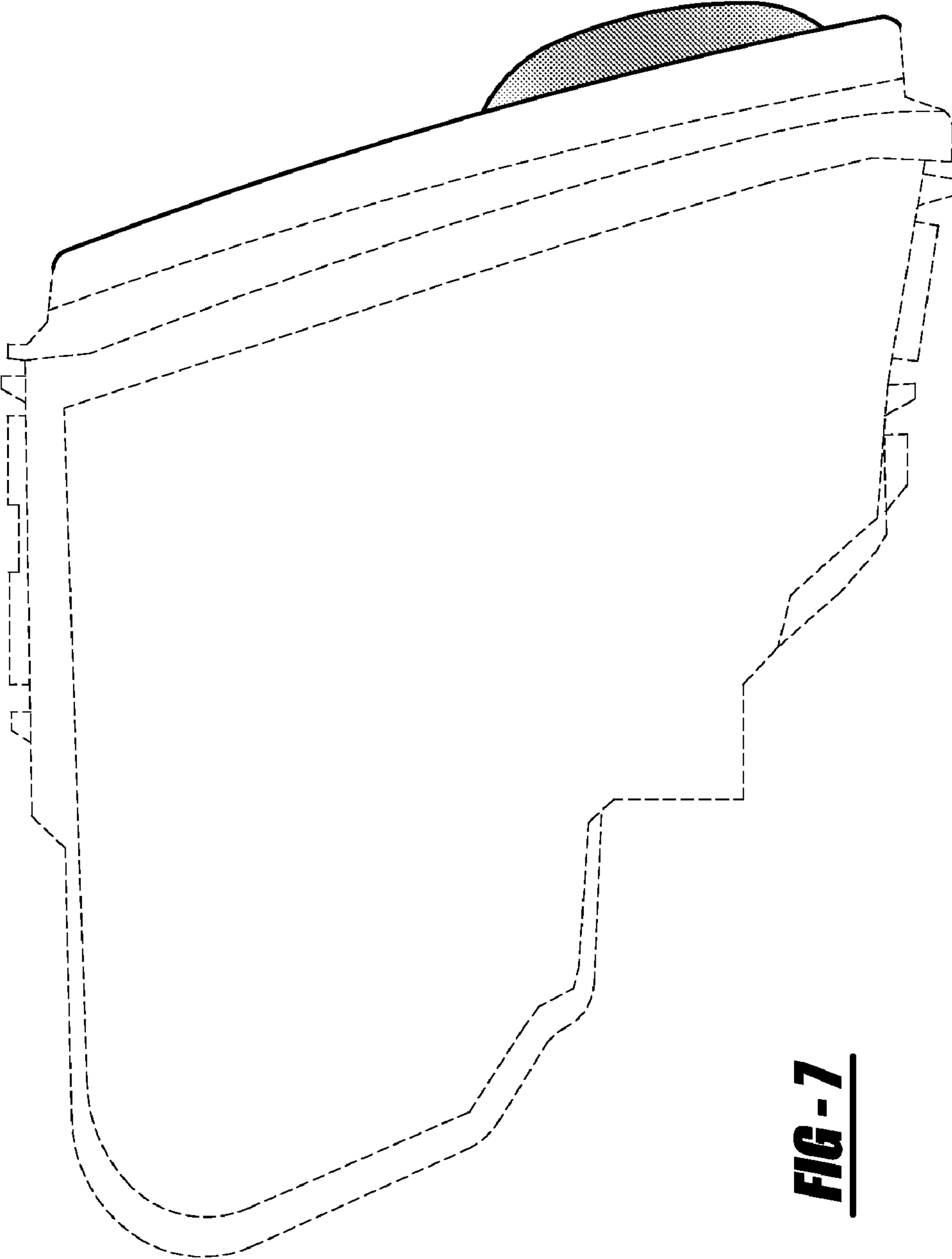

FIG - 7

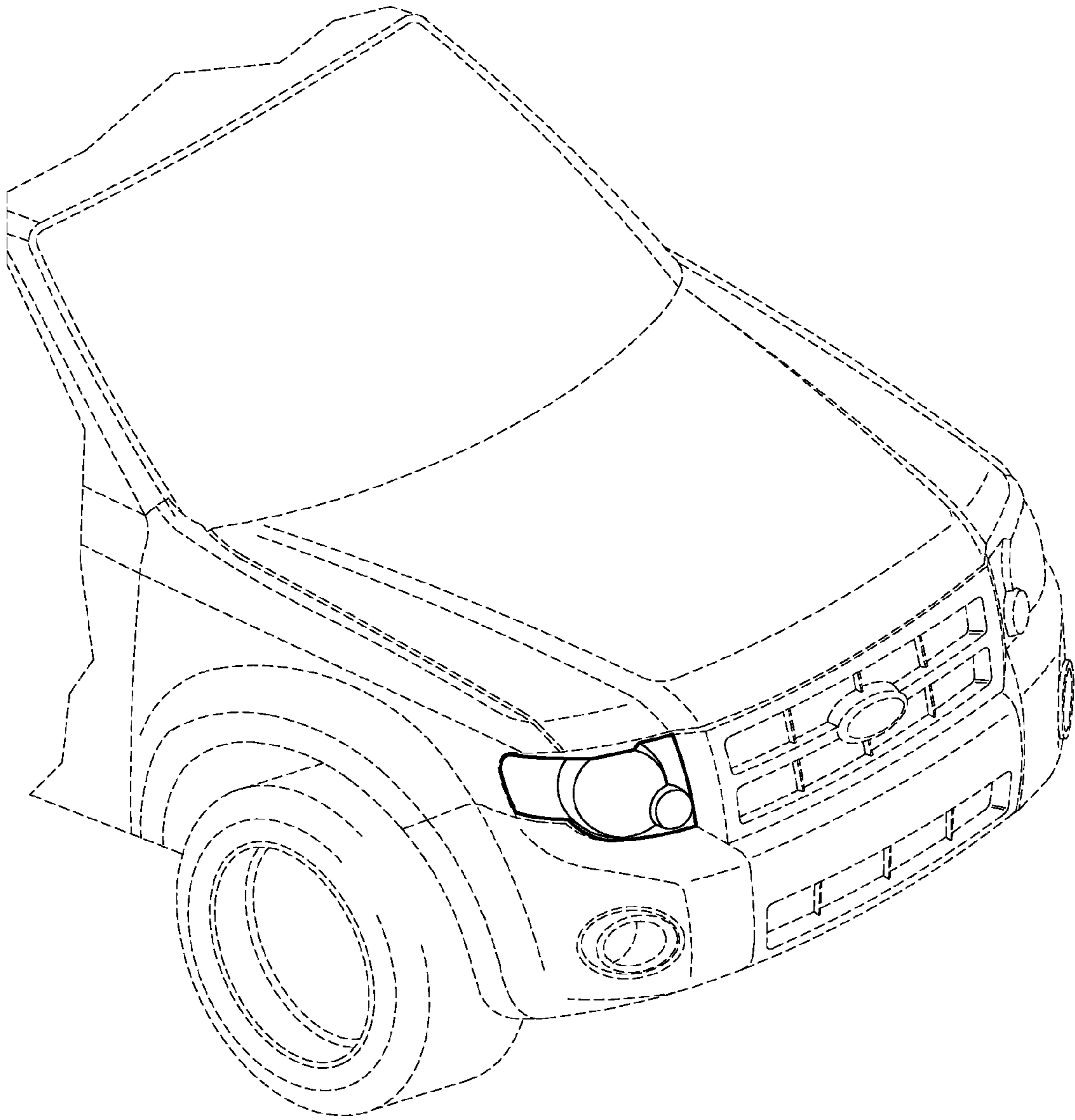

FIG - 8

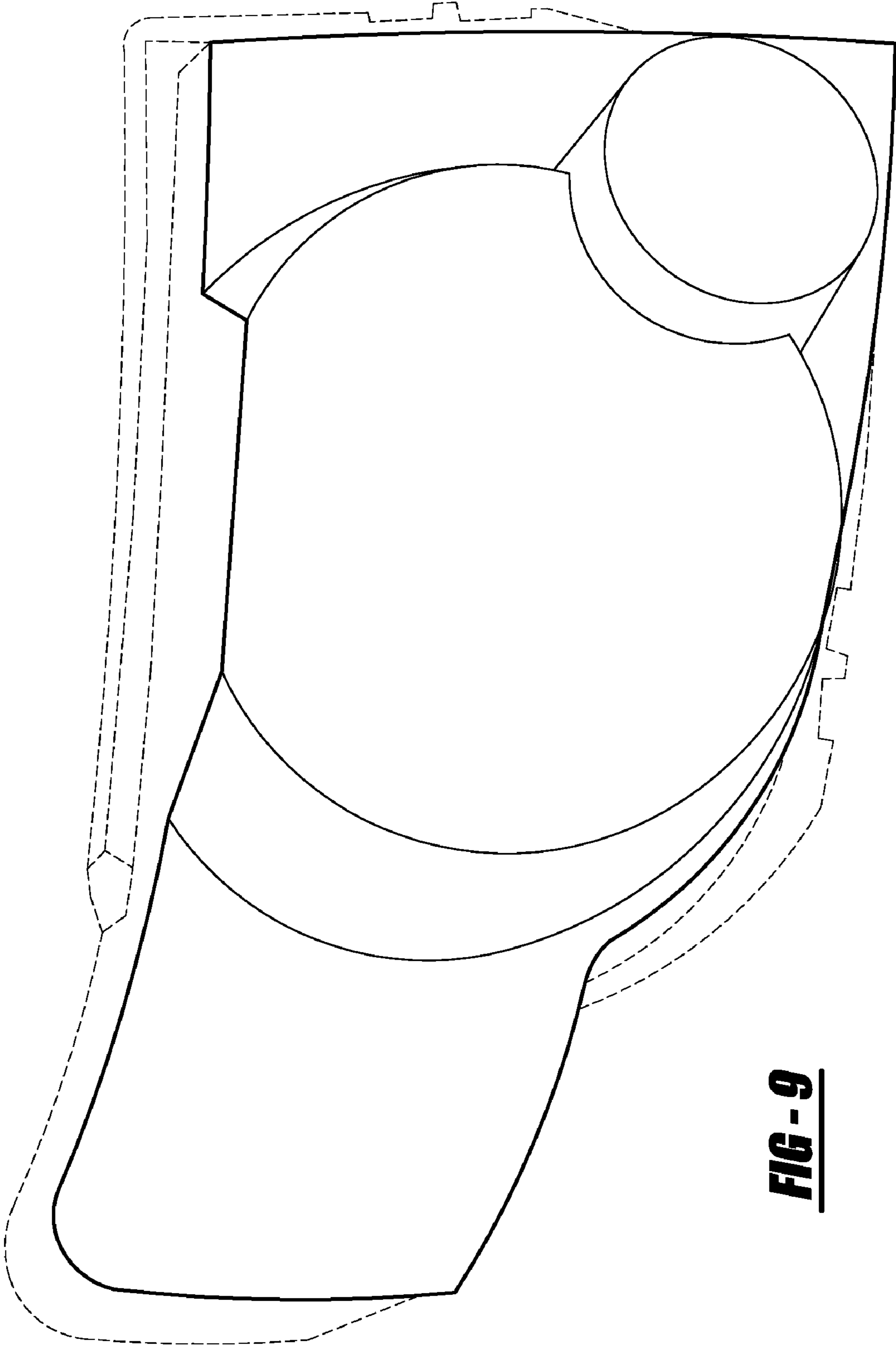

FIG - 9

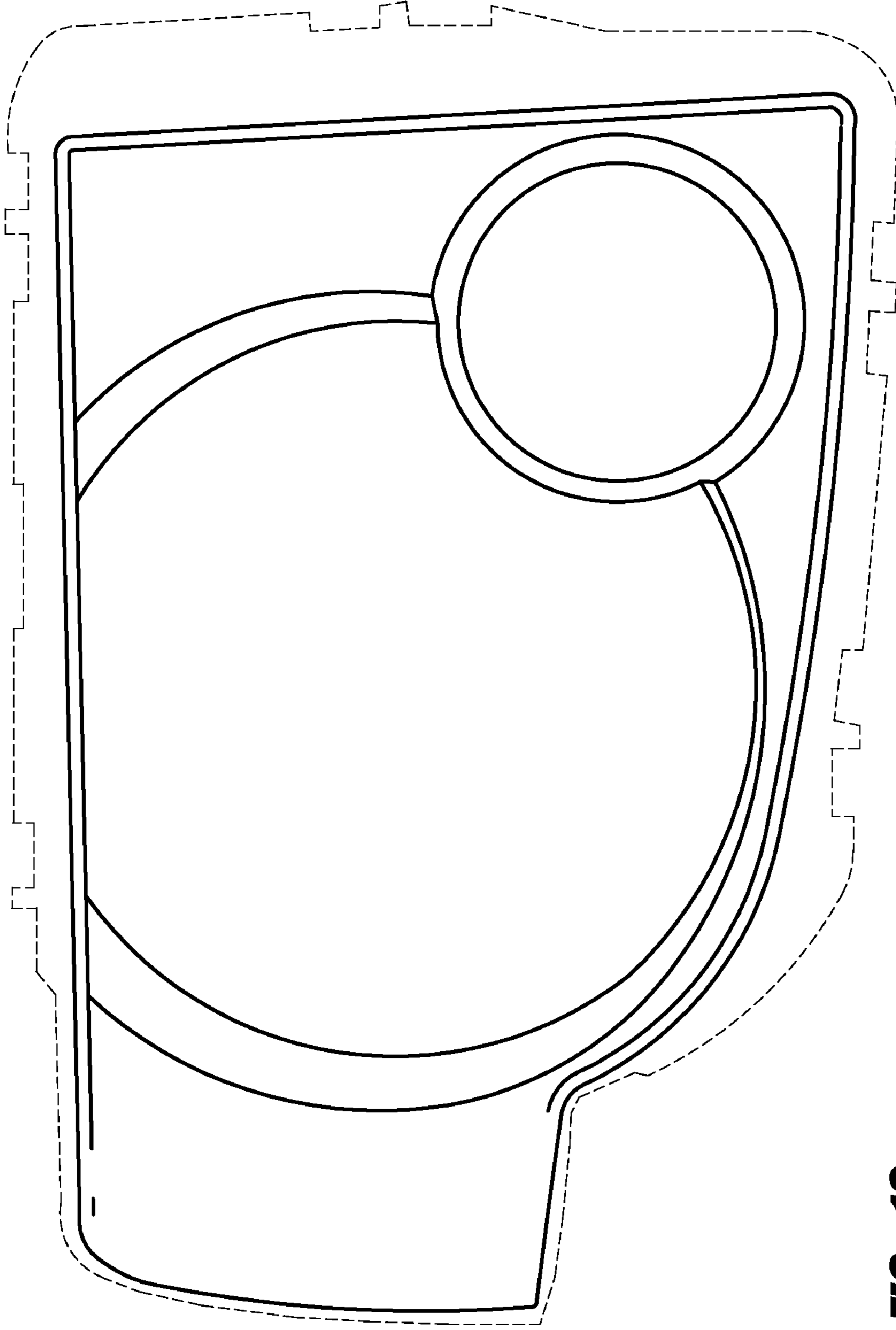

FIG - 10

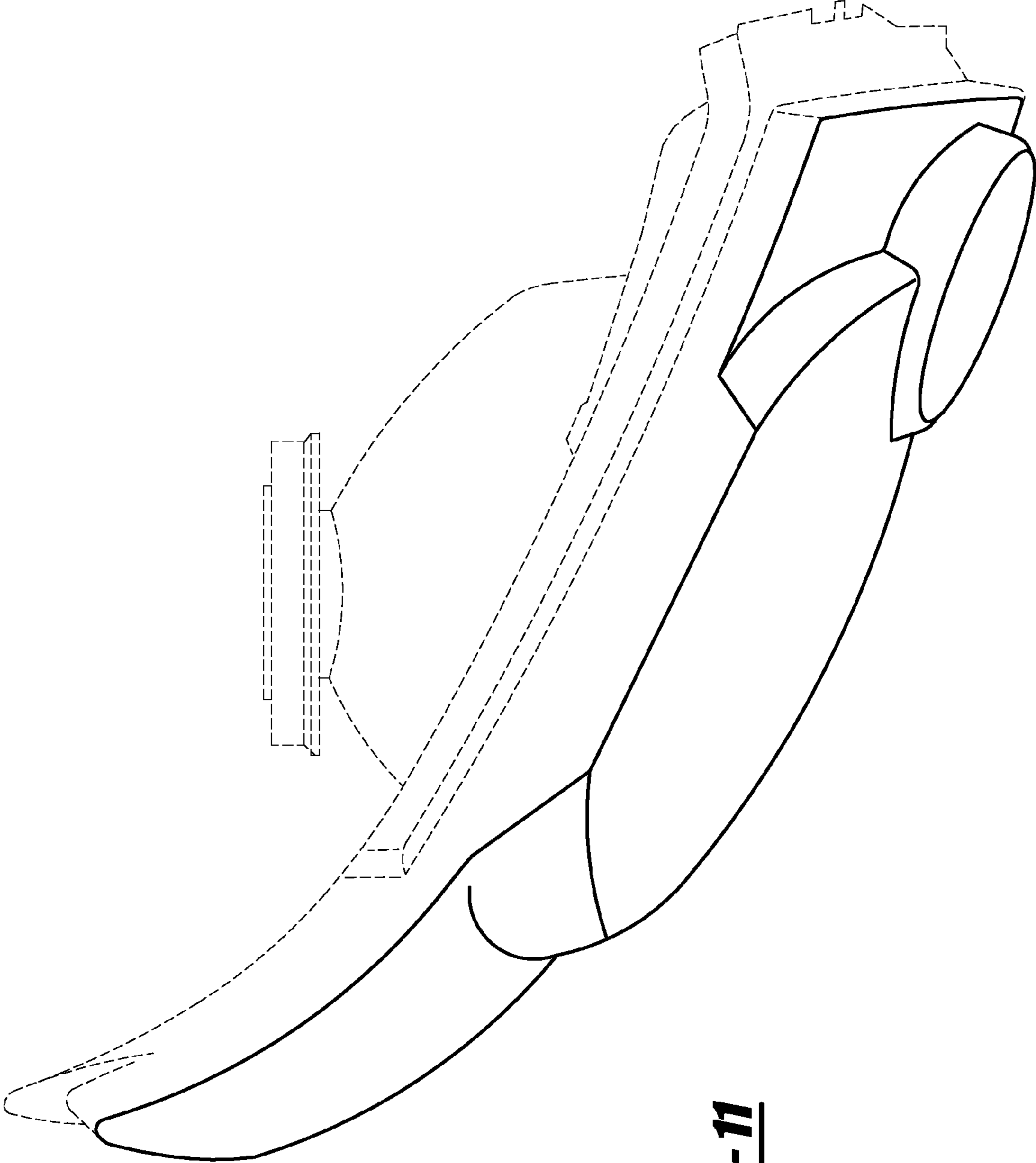

FIG - 11

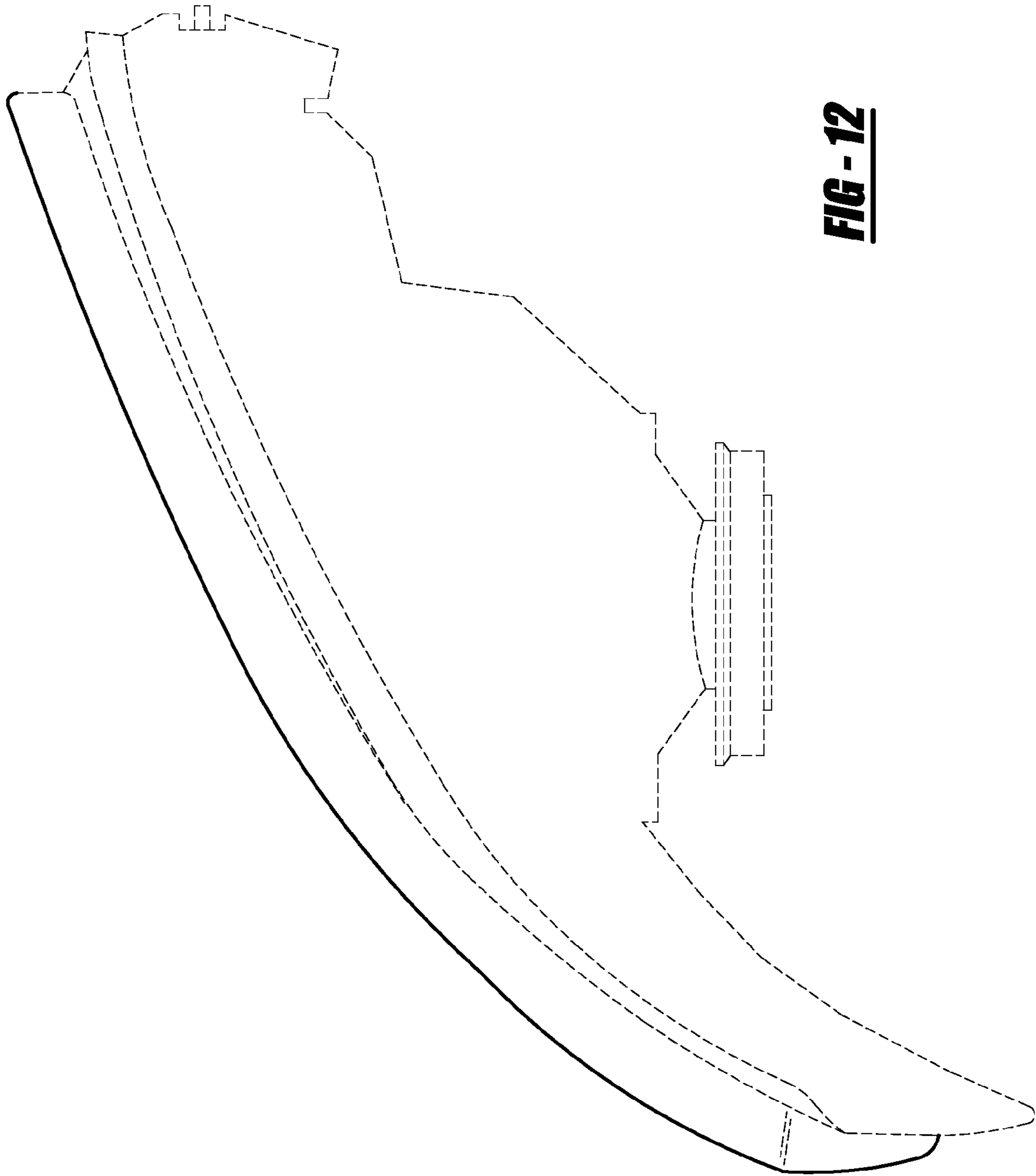

FIG - 12

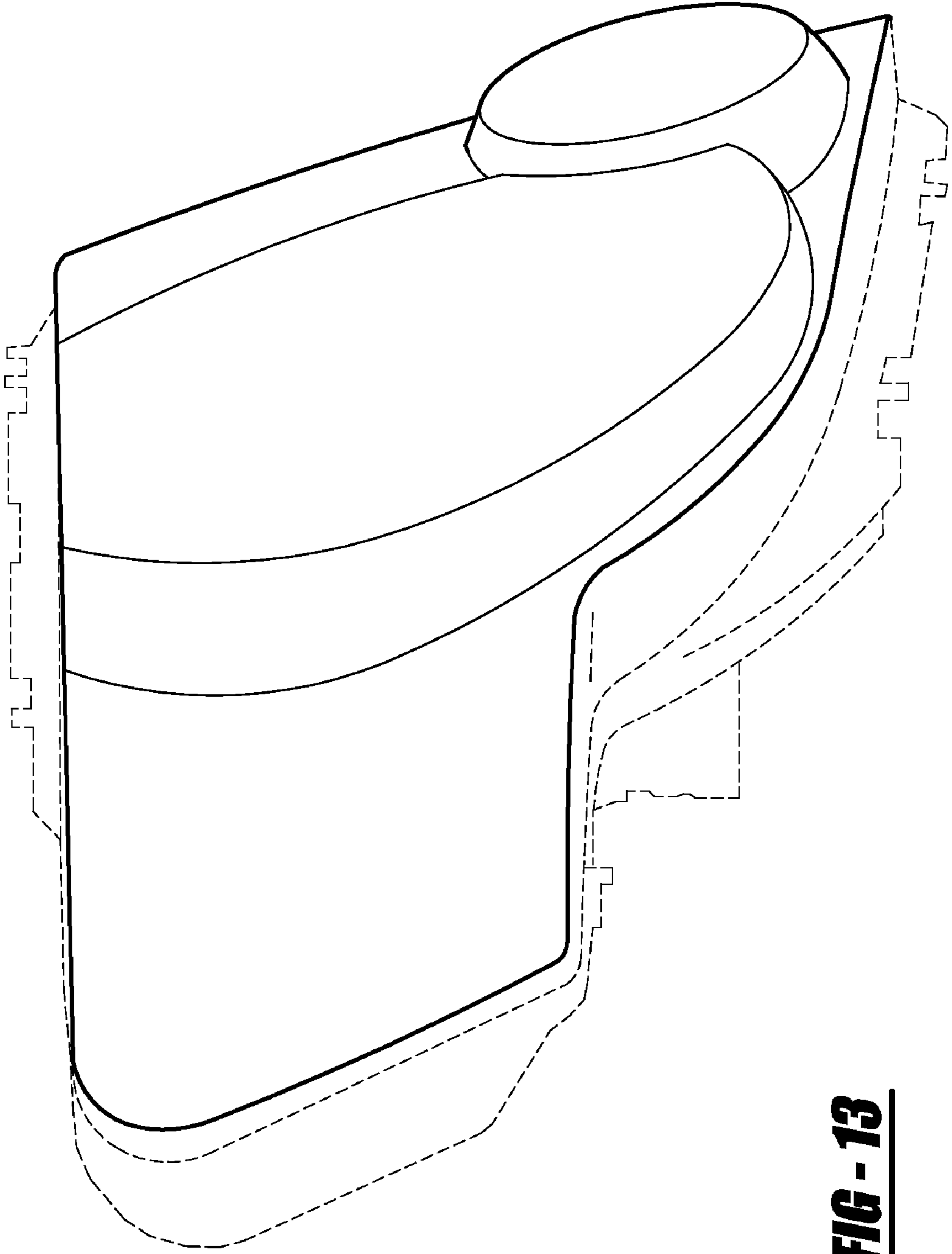

FIG - 13

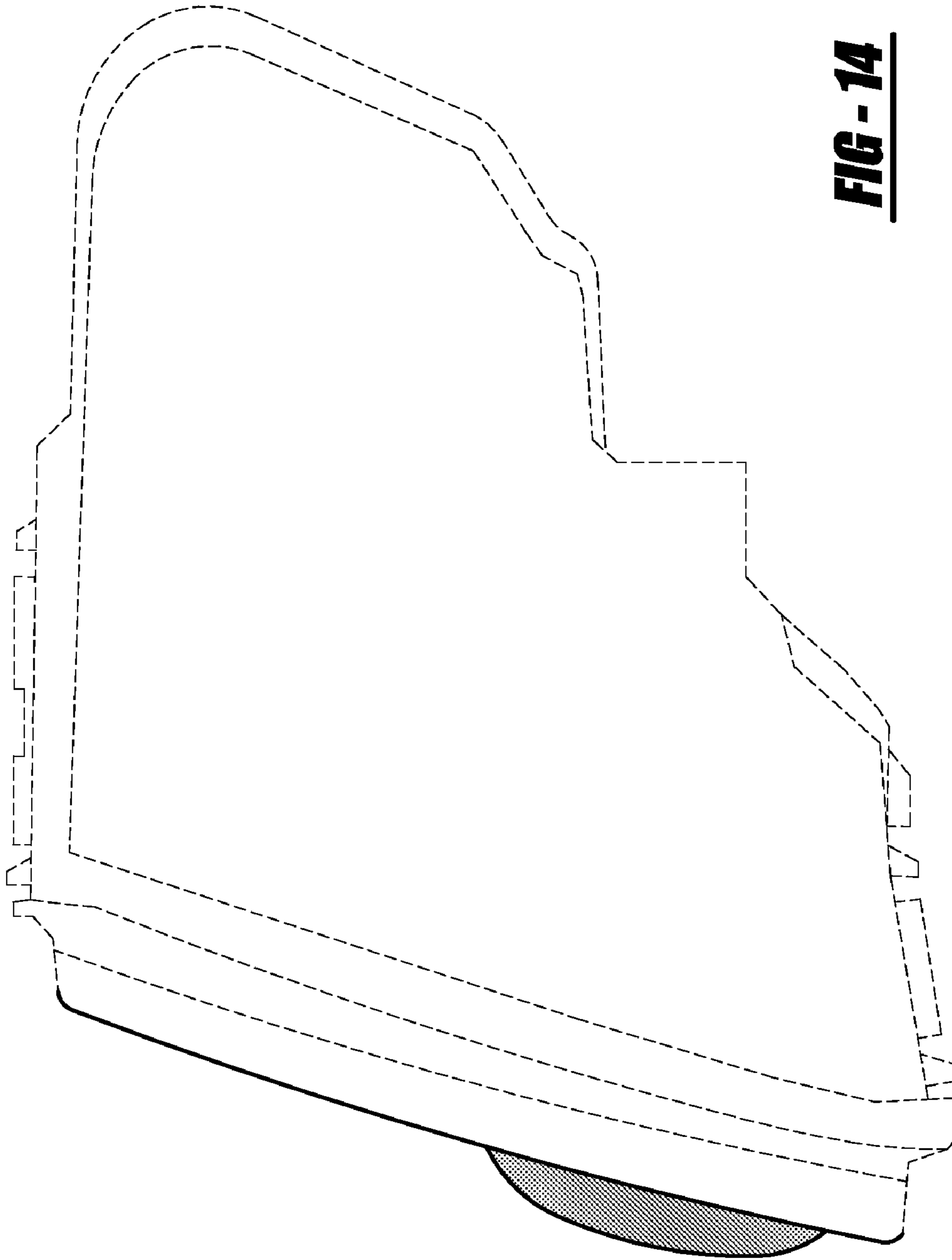

FIG - 14