



US00D559415S

(12) **United States Design Patent** (10) **Patent No.:** **US D559,415 S**  
**Gaffka et al.** (45) **Date of Patent:** **\*\* Jan. 8, 2008**

(54) **VEHICLE HEADLIGHT LENS**

(57) **CLAIM**

(75) Inventors: **Douglas Gaffka**, Northville, MI (US);  
**Scott Strong**, Farmington Hills, MI  
(US); **Wolfgang Gotschke**, Dearborn,  
MI (US); **Keith Rogman**, Fenton, MI  
(US)

The ornamental design for a vehicle headlight lens, as shown  
and described.

(73) Assignee: **Ford Global Technologies, LLC**,  
Dearborn, MI (US)

**DESCRIPTION**

(\*\*) Term: **14 Years**

FIG. 1 is a frontal perspective view of a left vehicle  
headlight lens attached to a vehicle, no part of the vehicle is  
claimed;

(21) Appl. No.: **29/242,333**

FIG. 2 is a perspective view of the left vehicle headlight  
lens;

(22) Filed: **Nov. 9, 2005**

FIG. 3 is a front elevational view of the left vehicle headlight  
lens;

(51) **LOC (8) Cl.** ..... **26-06**

FIG. 4 is a top plan view of the left vehicle headlight lens;

(52) **U.S. Cl.** ..... **D26/28**

FIG. 5 is a bottom plan view of the left vehicle headlight  
lens;

(58) **Field of Classification Search** ..... D26/28-36;  
362/459-468, 475-478, 485-487  
See application file for complete search history.

FIG. 6 is a left side elevational view of the left vehicle  
headlight lens;

FIG. 7 is a side (45 degrees right of front) view of the left  
vehicle headlight lens;

(56) **References Cited**

**U.S. PATENT DOCUMENTS**

D535,763 S \* 1/2007 Pfeiffer ..... D26/28  
D536,113 S \* 1/2007 Pfeiffer ..... D26/28  
D537,180 S \* 2/2007 Hsu ..... D26/28  
D540,482 S \* 4/2007 Miwa et al. .... D26/28  
D541,445 S \* 4/2007 Lin ..... D26/28  
D546,486 S \* 7/2007 Sinkwitz et al. .... D26/28

FIG. 8 is a front elevational view of a vehicle headlight lens  
illustrated in FIGS. 1-7, showing a right vehicle headlight  
lens, with the vehicle shown in broken lines and forming no  
part of the claimed design;

FIG. 9 is a perspective view of the right vehicle headlight  
lens;

FIG. 10 is a front elevational view of the right vehicle  
headlight lens;

**OTHER PUBLICATIONS**

North American International Auto Show (Detroit), *Ford Mustang  
GT Concept*, Jan. 9, 2003.  
New York Auto Show, *Ford Concept Mustang GTR*, Apr. 9, 2004.  
StreetFire.net, *2007 Mustang Cobra*, Jan. 22, 2005 [http://forums.  
streetfire.net/showthread.php?t=146](http://forums.streetfire.net/showthread.php?t=146).  
Muscular Mustangs Online, *2007 SVT Mustang Cobra*, Mar. 10,  
2005 <http://www.muscularmustangs.com/2005/07cobra.php>.

FIG. 11 is a top plan view of the right vehicle headlight lens;

FIG. 12 is a bottom plan view of the right vehicle headlight  
lens;

FIG. 13 is a right side elevational view of the right vehicle  
headlight lens; and,

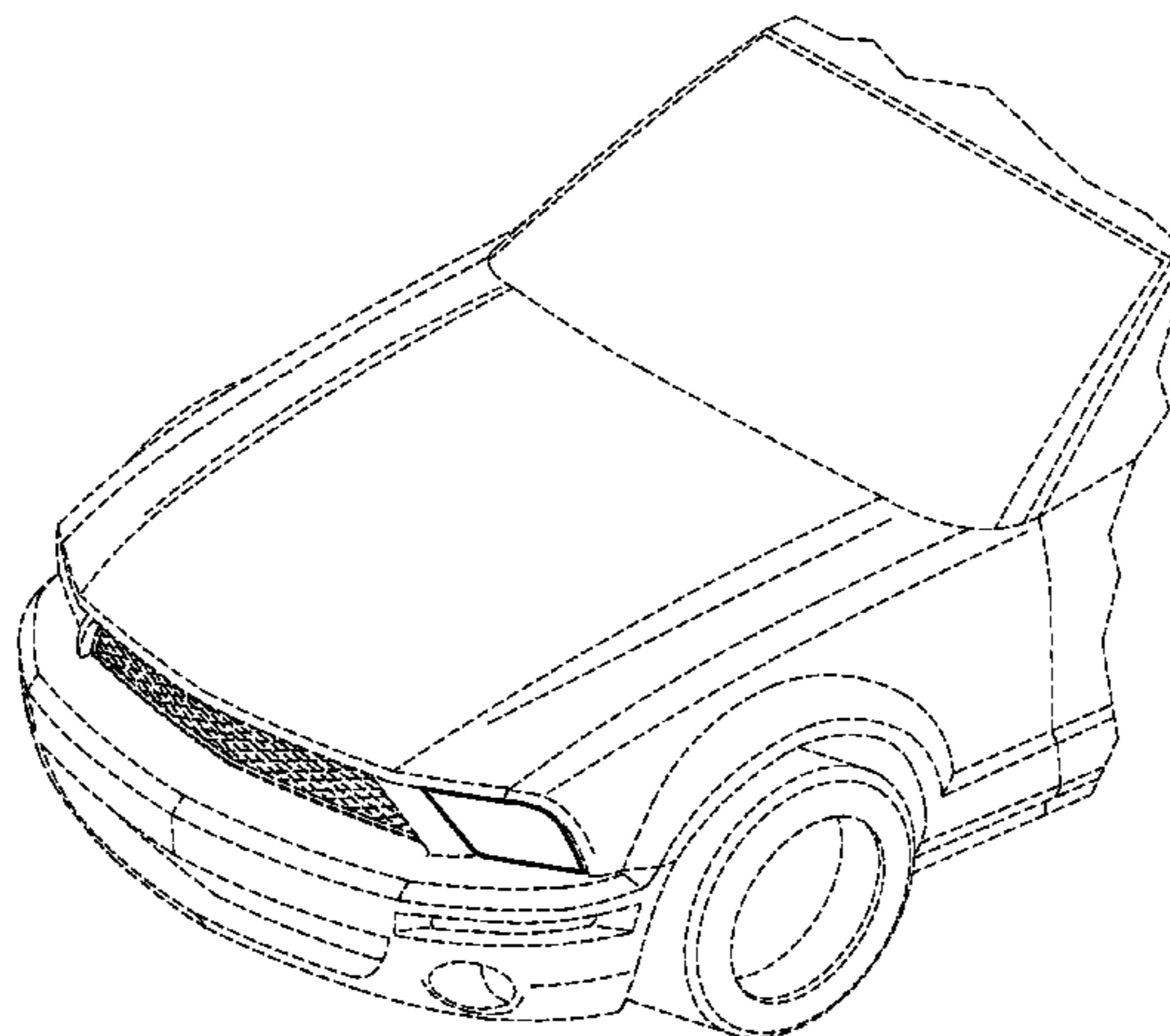
FIG. 14 is a side (45 degrees left of front) view of the right  
vehicle headlight lens.

(Continued)

The phantom lines are not a part of the claimed invention.

*Primary Examiner*—Marcus A. Jackson  
(74) *Attorney, Agent, or Firm*—Damian Porcari

**1 Claim, 14 Drawing Sheets**



OTHER PUBLICATIONS

Autoblog.com, *Ford Shelby Cobra GT500*, Mar. 22, 2005  
<http://www.autoblog.com/entry/1234000660036890/>.

Autoblog.com, *New York Auto Show: Mustang Shelby Cobra GT500*, Mar. 23, 2005 <http://www.autoblog.com/entry/1234000297037364/>.

The Car Connection, *Preview: 2007 Ford Shelby Cobra GT500*, Mar. 28, 2005 <http://www.thecarconnection.com/index.asp?article=8328>.

Mustang Heaven Online, *2007 Shelby Cobra GT500*, Mar. 2005 [http://www.mustangheaven.com/stangspecs/2007cobra/07cobra\\_main.htm](http://www.mustangheaven.com/stangspecs/2007cobra/07cobra_main.htm).

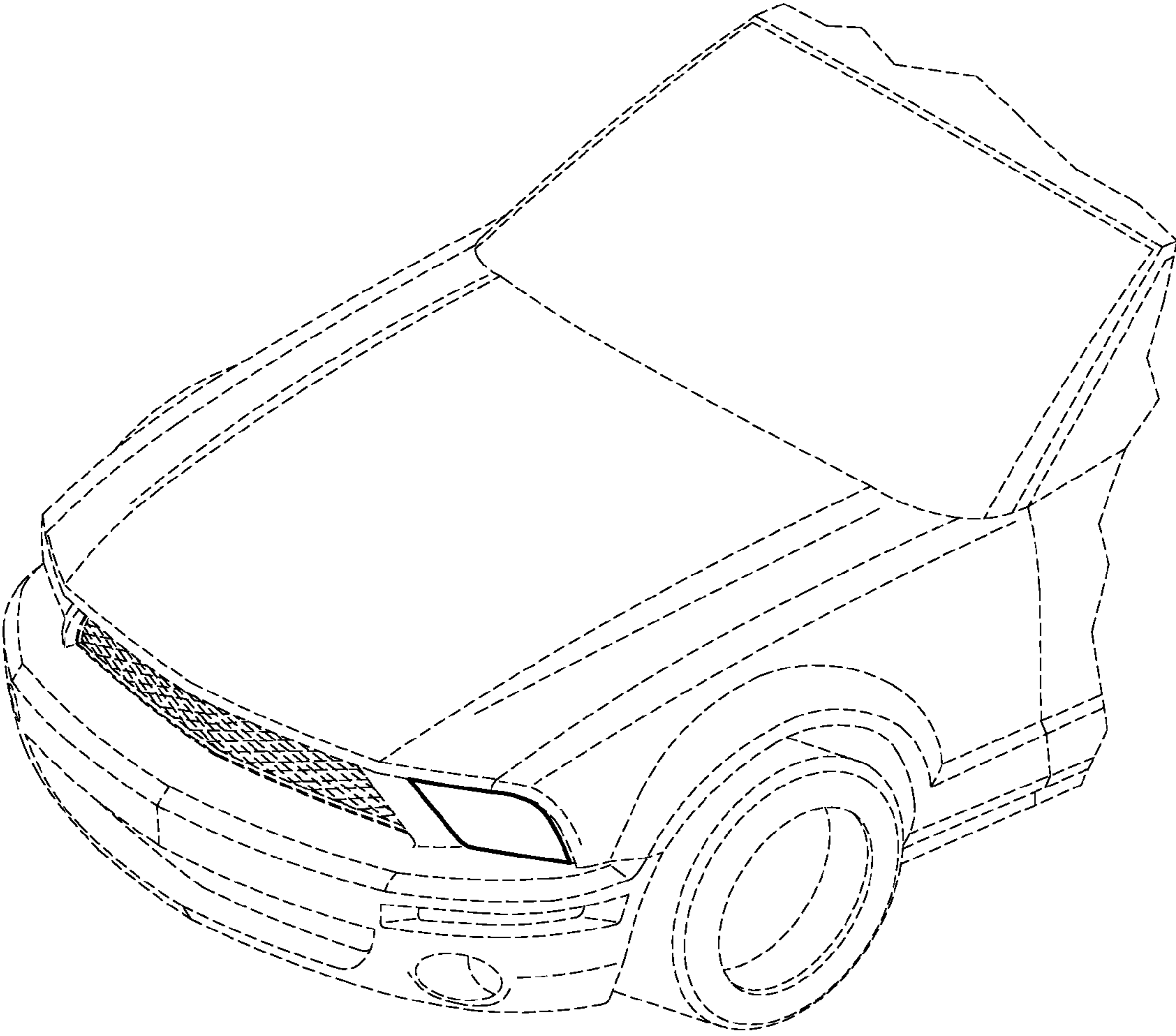
Motor Trend Online, *It's the Shelby Mustang Cobra!*, Motor Trend Mar. 2005 [http://motortrend.com/future/spied/112\\_0503\\_news\\_shelby/](http://motortrend.com/future/spied/112_0503_news_shelby/).

Motor Trend Online, *First Look: 2007 Ford Shelby GT500*, May 2005 [http://motortrend.com/roadtests/coupe/112\\_0505\\_fordshelby/](http://motortrend.com/roadtests/coupe/112_0505_fordshelby/).

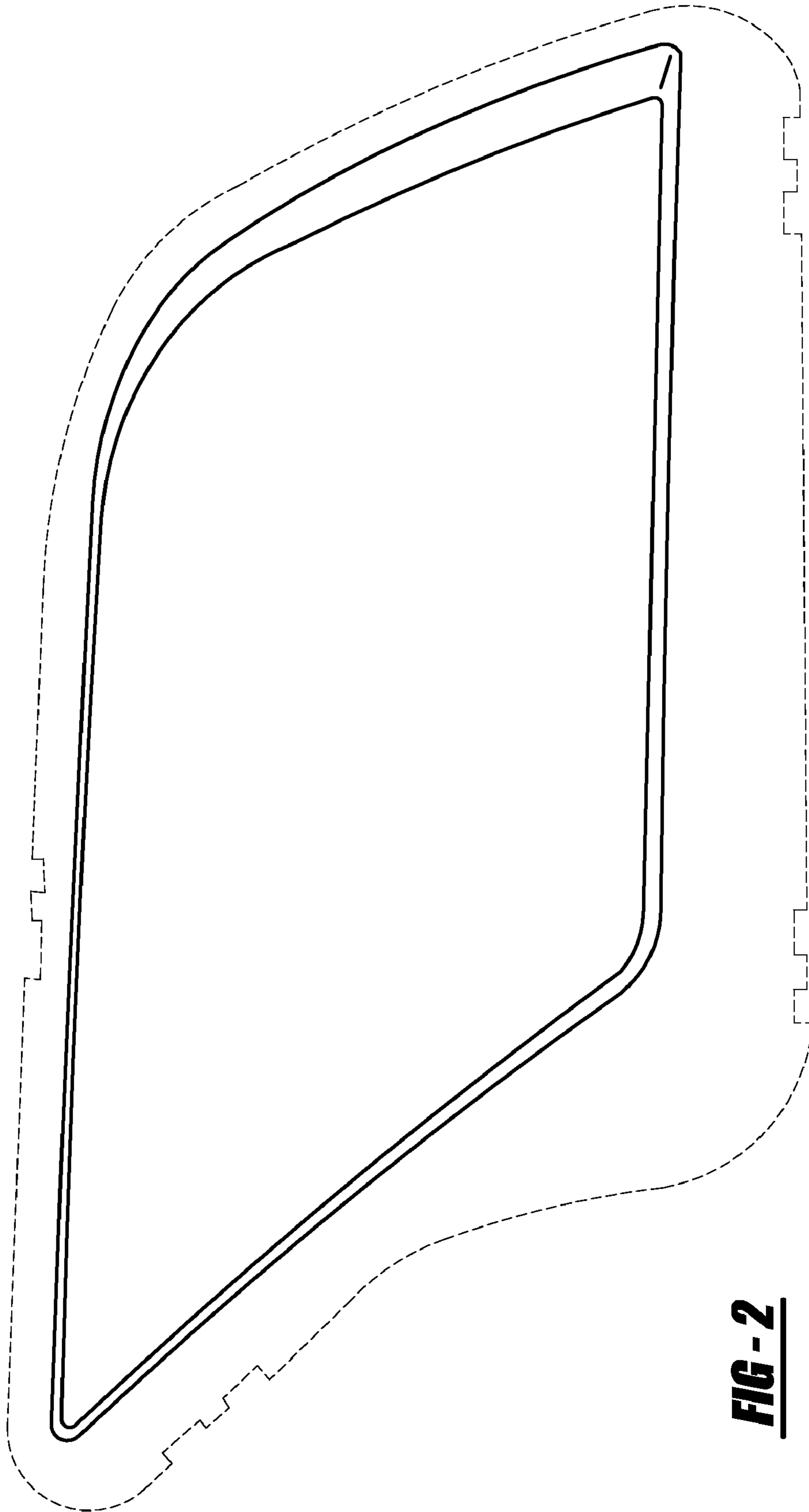
Automotive News, *FORD*, p. 31, Aug. 8, 2005.

Motor Trend Online, *Future Vehicle Forecast: 2007 Ford Mustang Shelby GT 500*, Sep. 2005, [http://www.motortrend.com/future/spied/112\\_2007fvf/index4.html](http://www.motortrend.com/future/spied/112_2007fvf/index4.html).

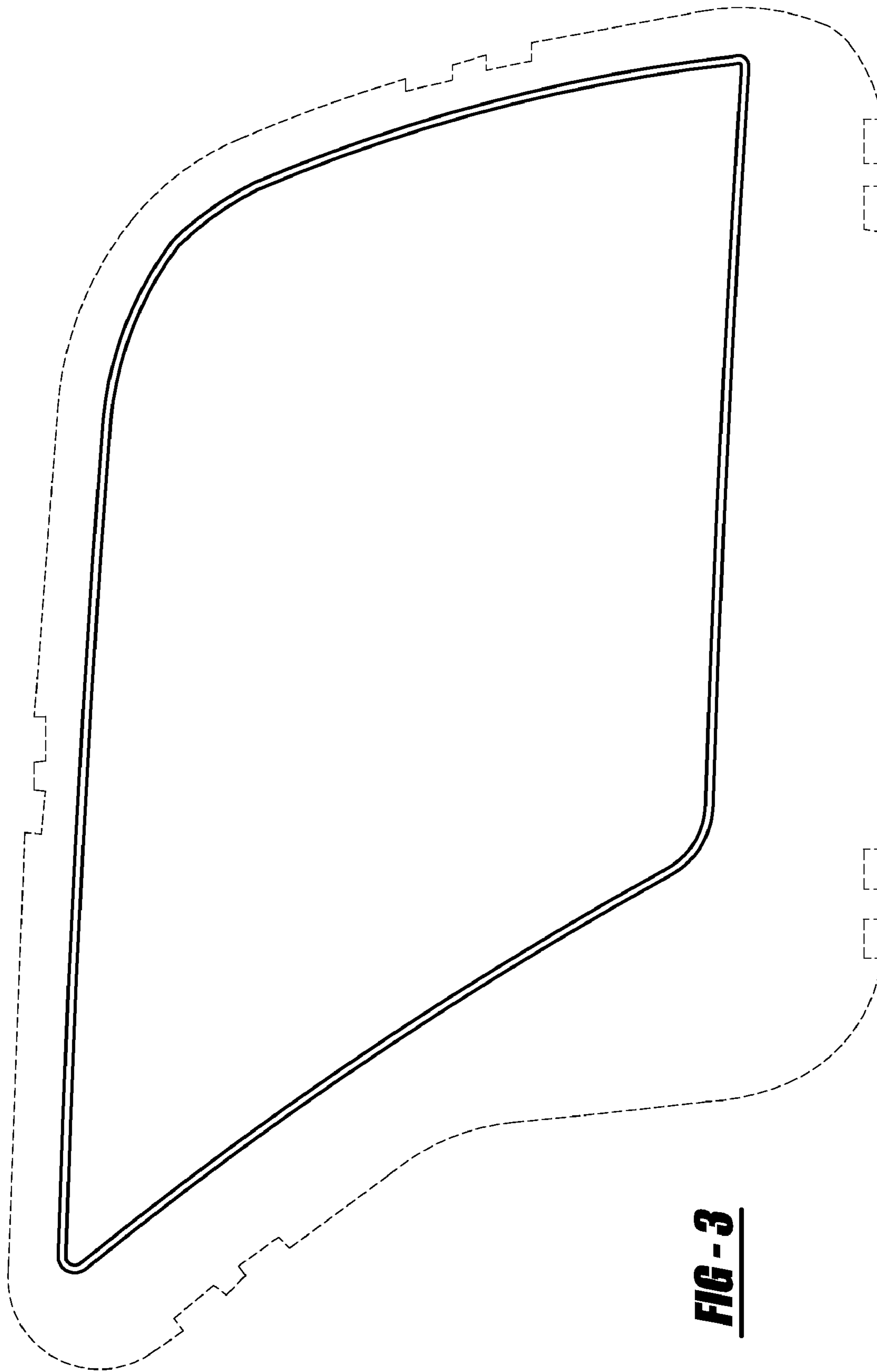
\* cited by examiner



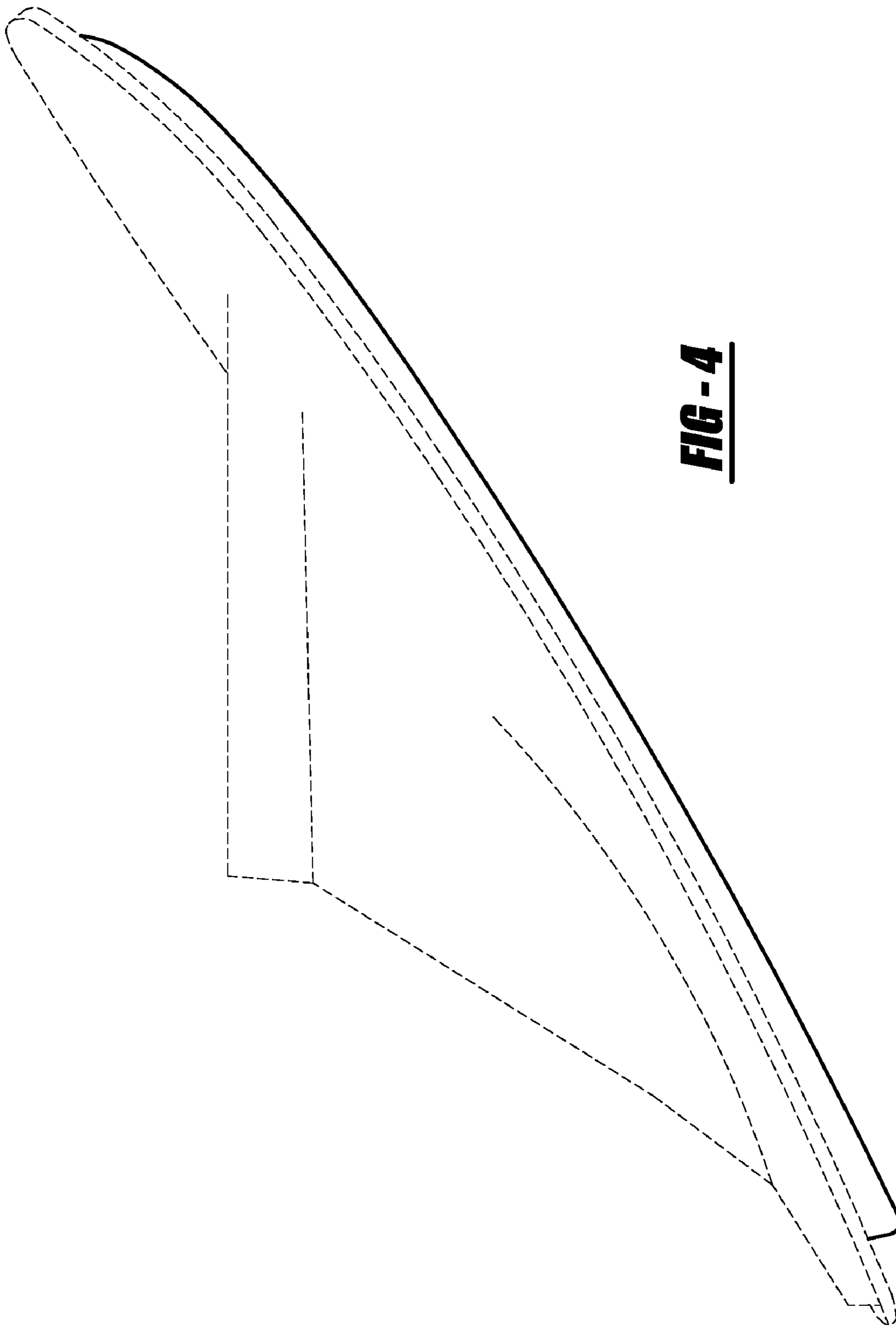
**FIG - 1**



**FIG - 2**

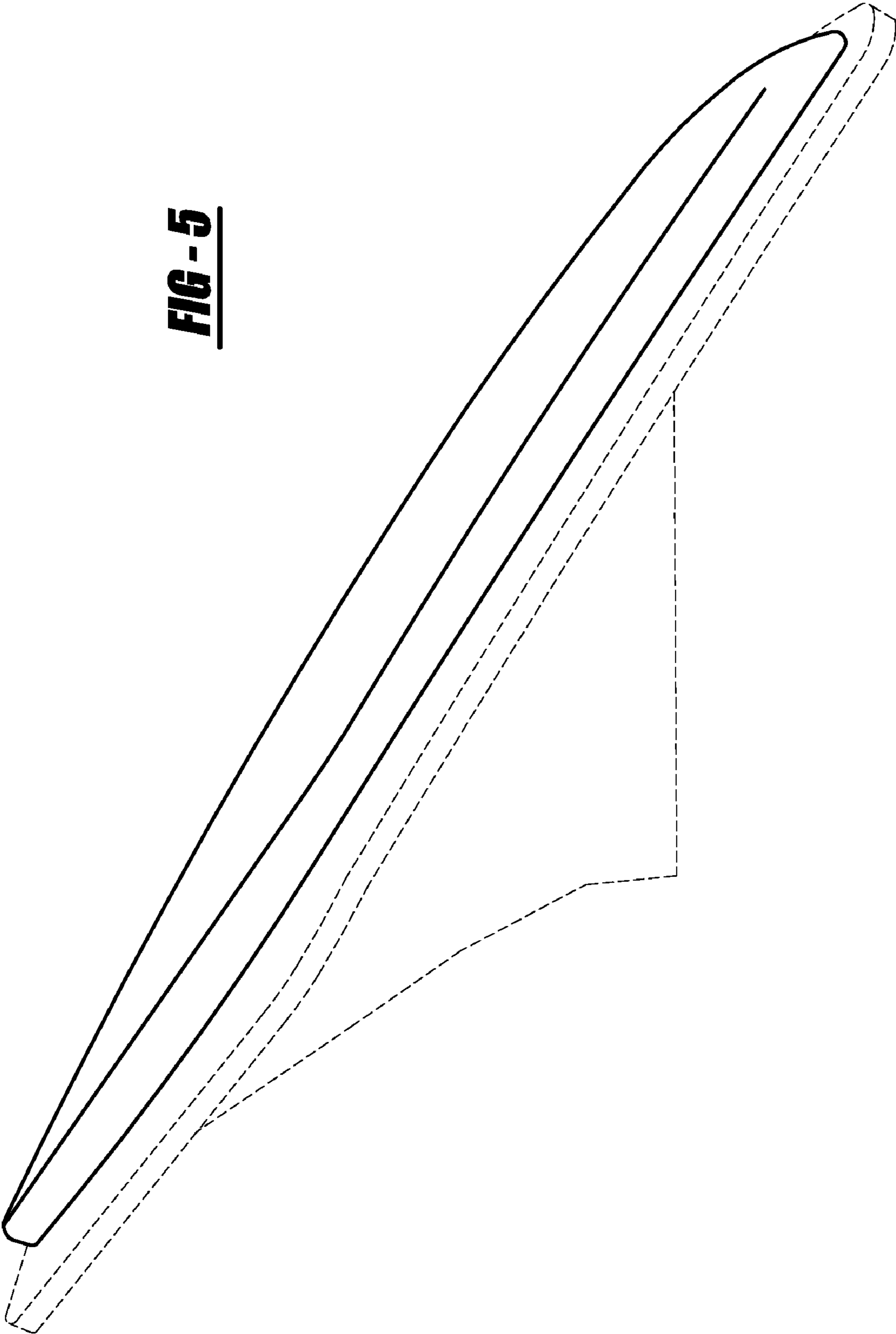


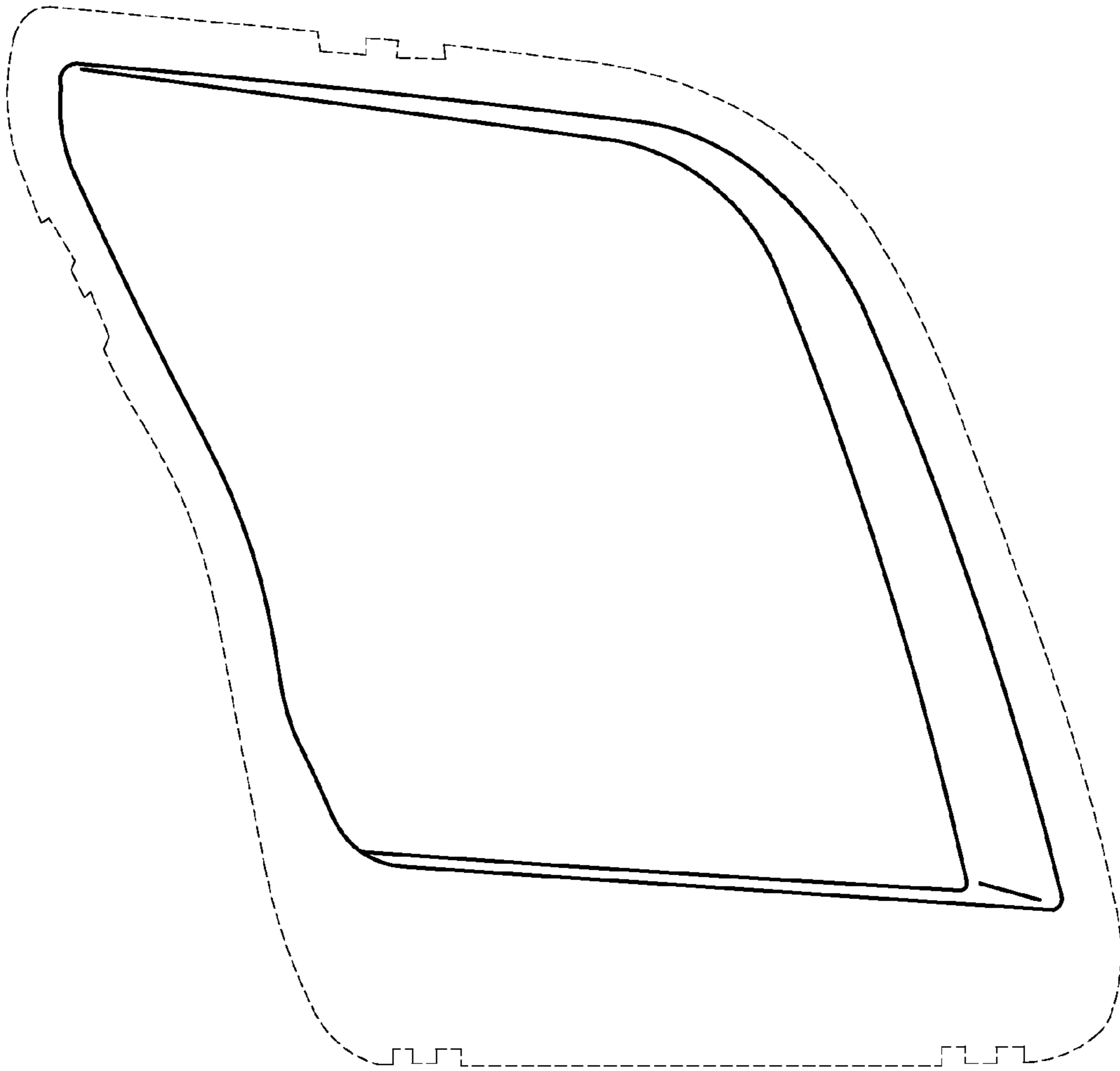
**FIG - 3**



**FIG - 4**

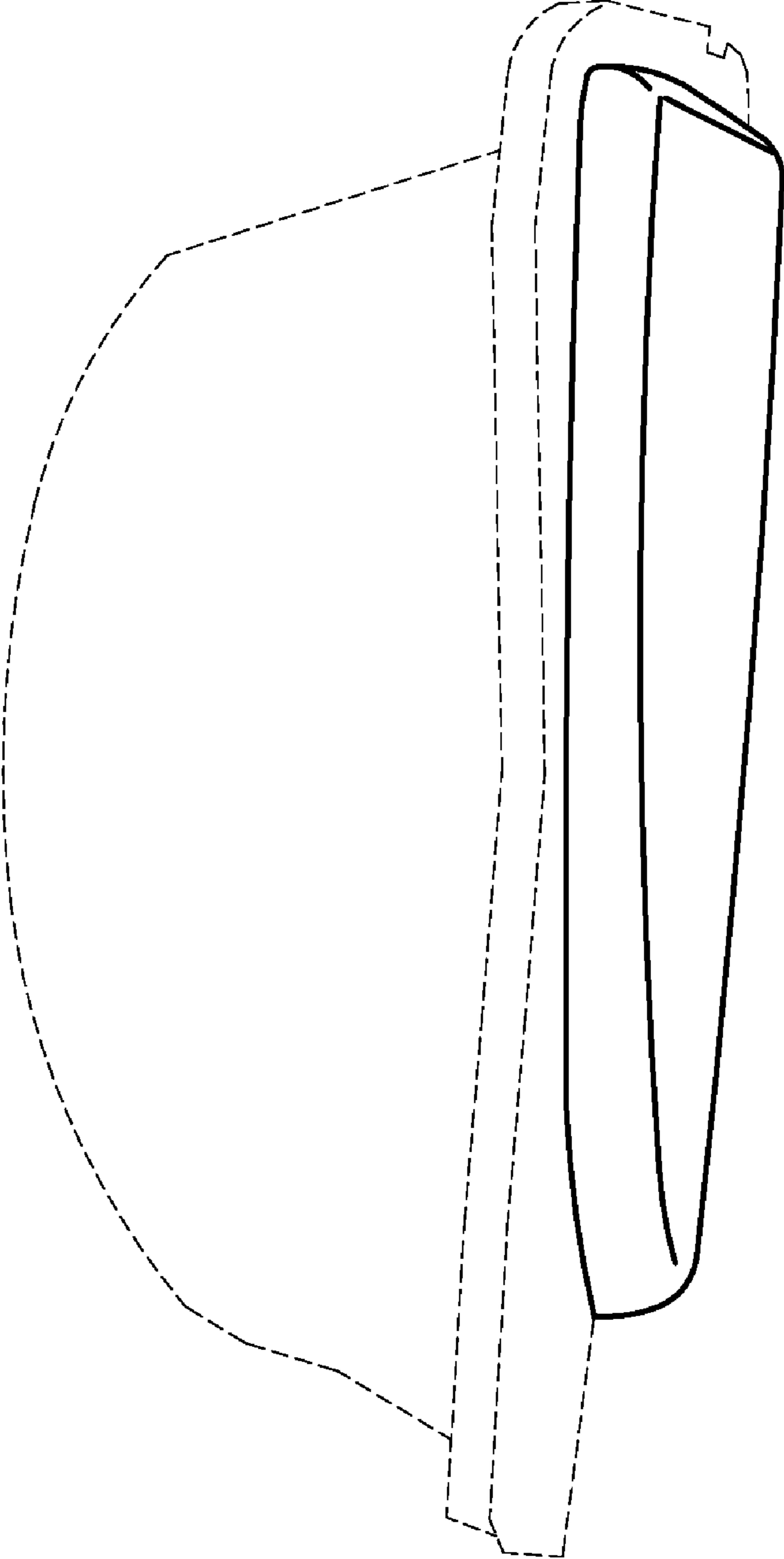
**FIG - 5**



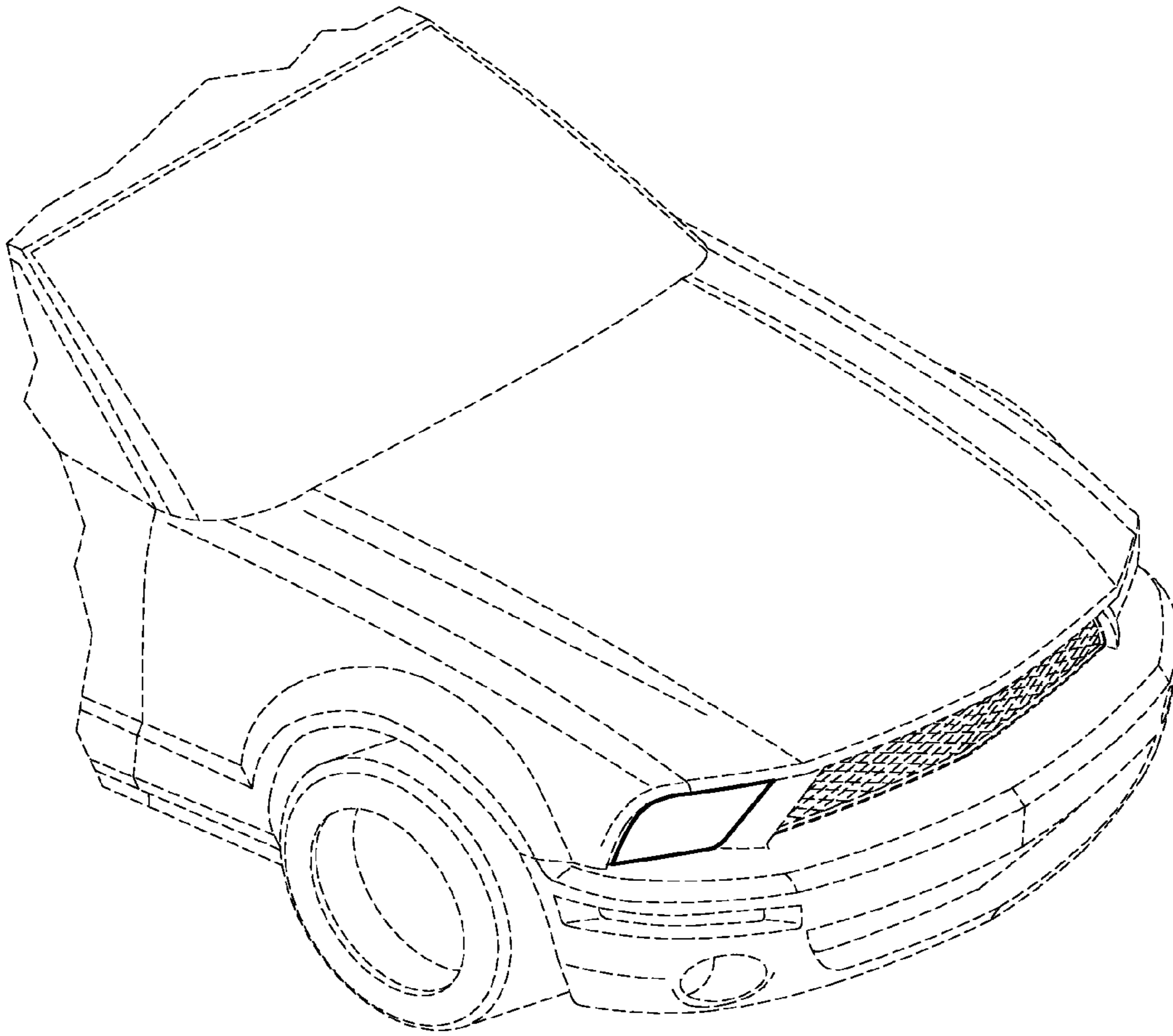


**FIG - 6**

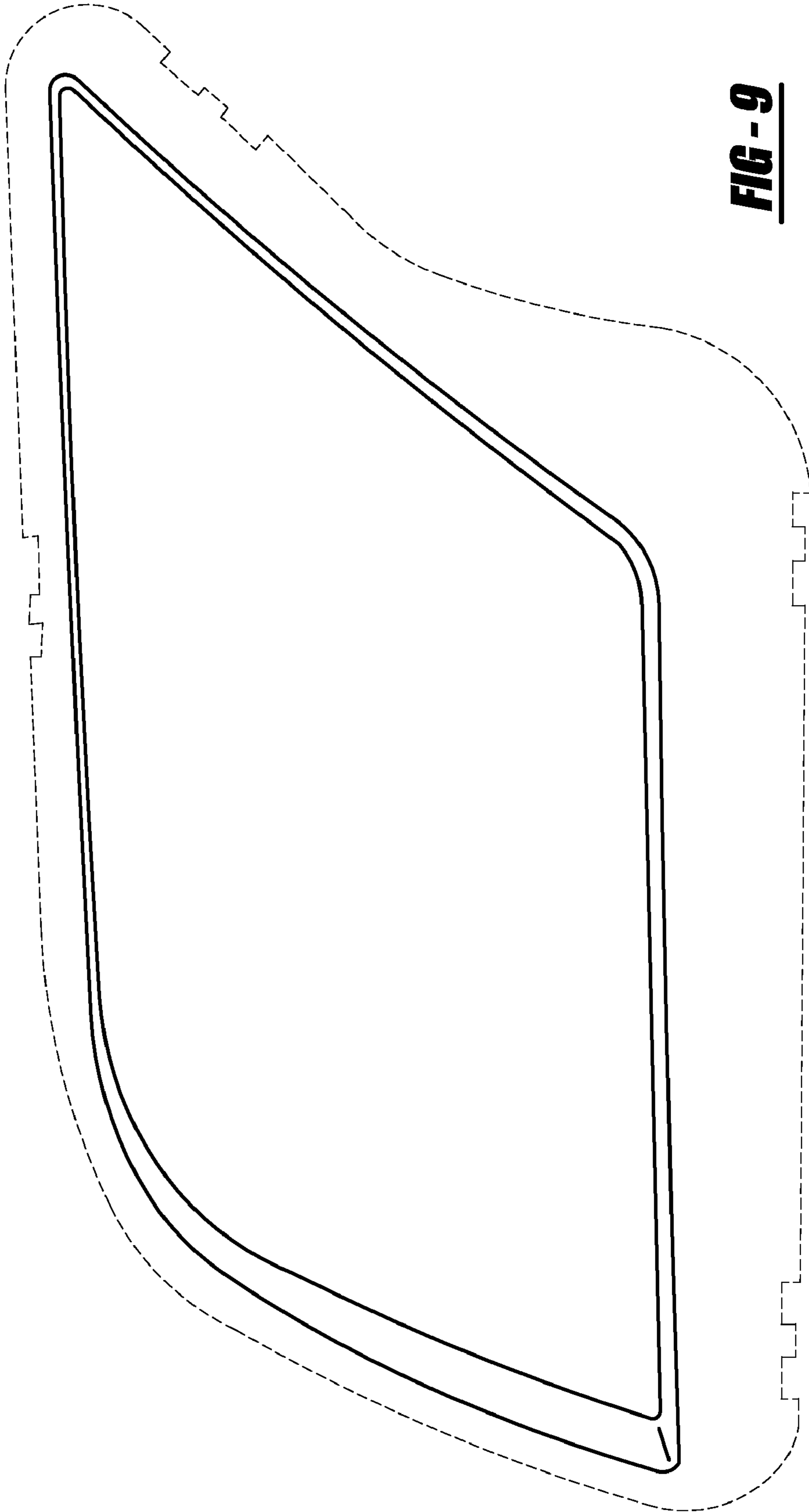




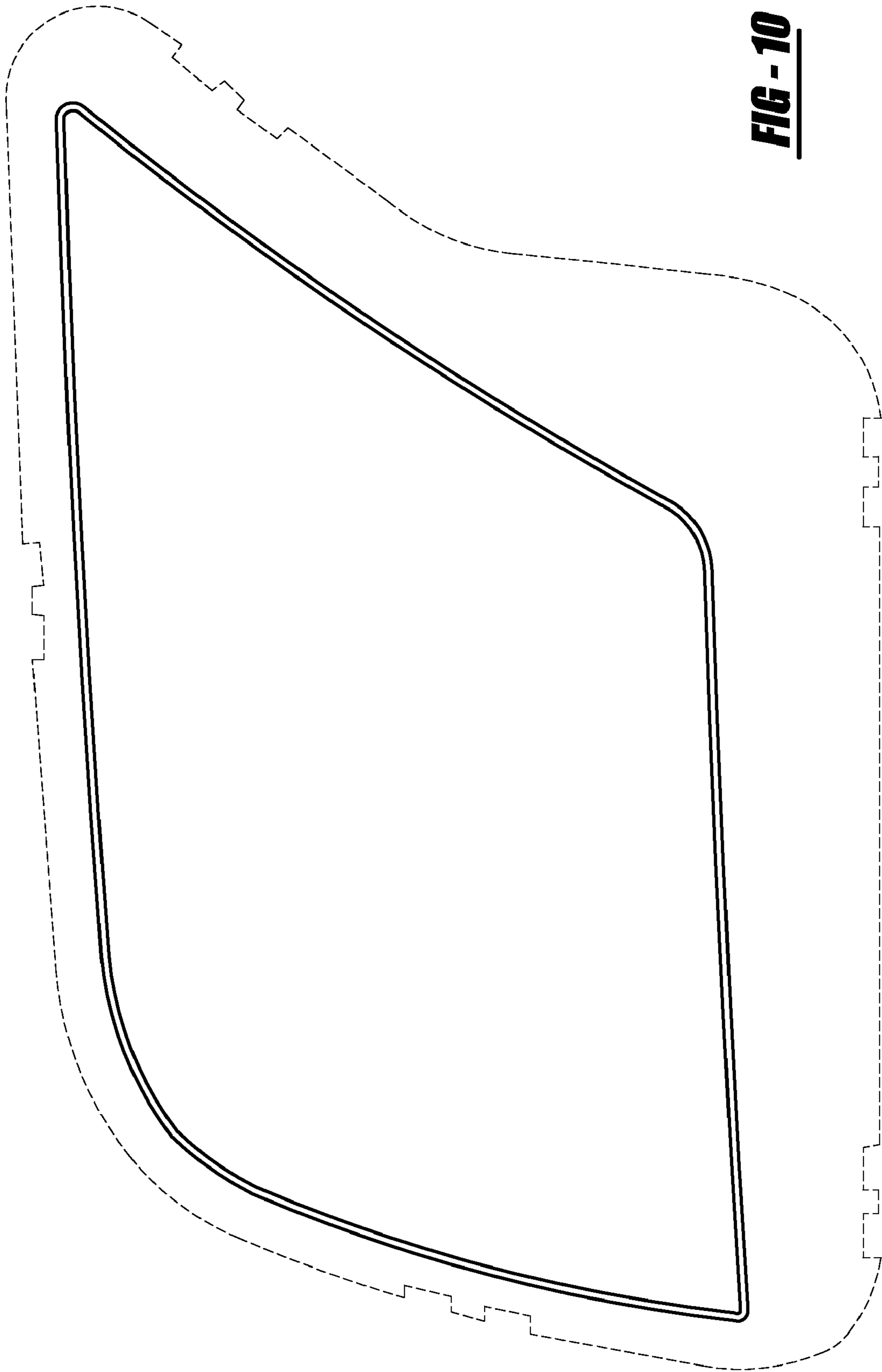
**FIG - 7**



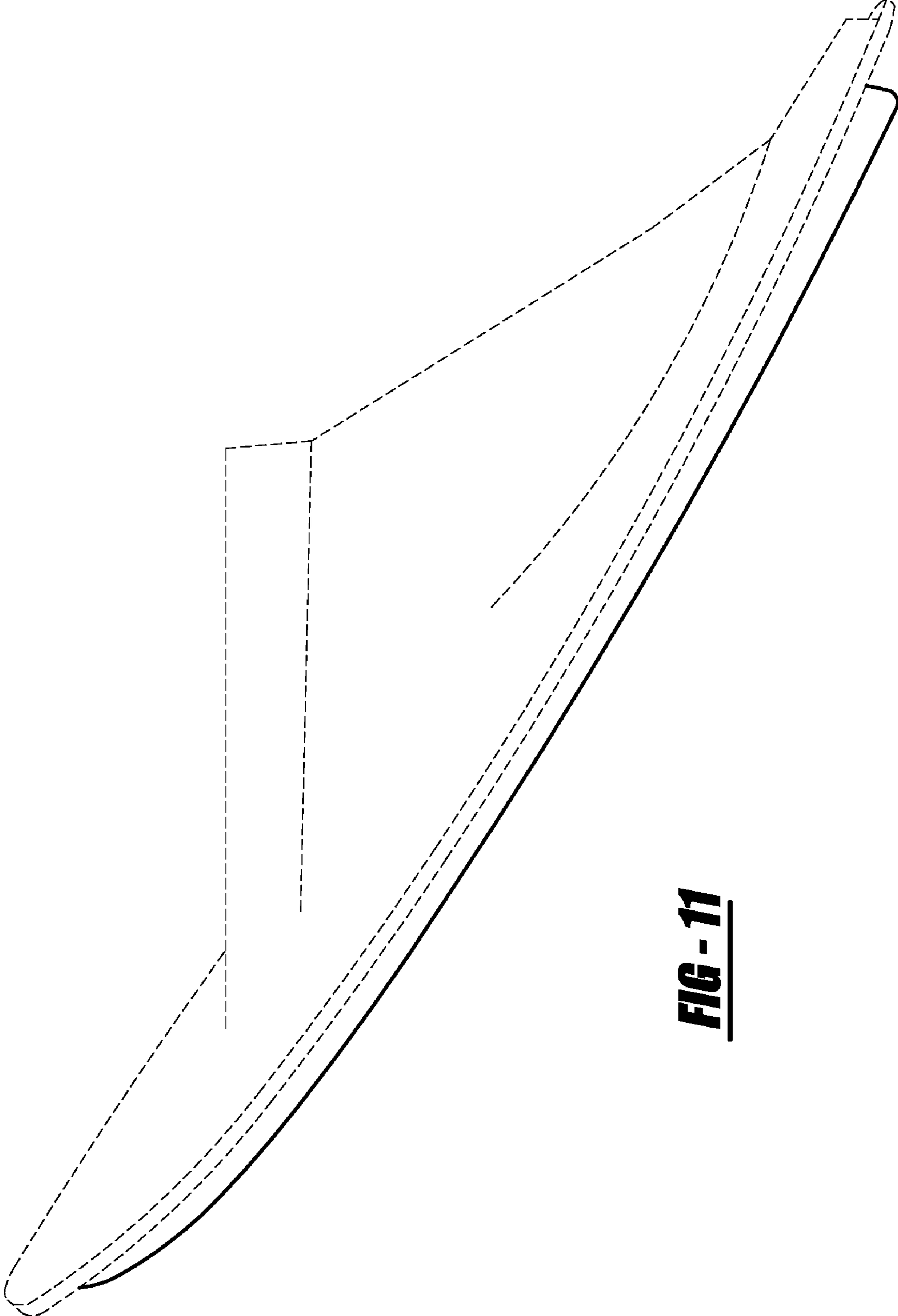
**FIG - 8**



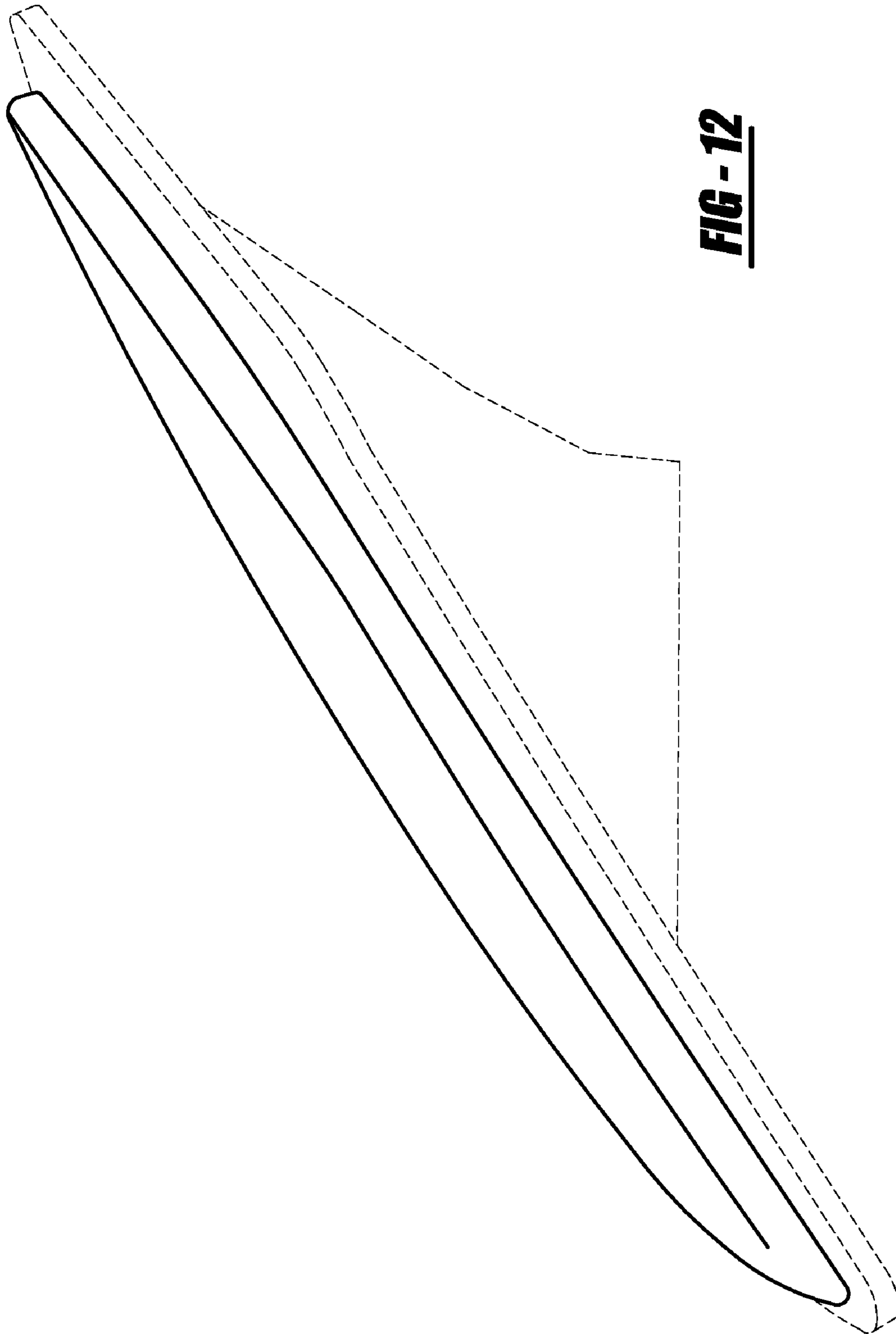
**FIG - 9**



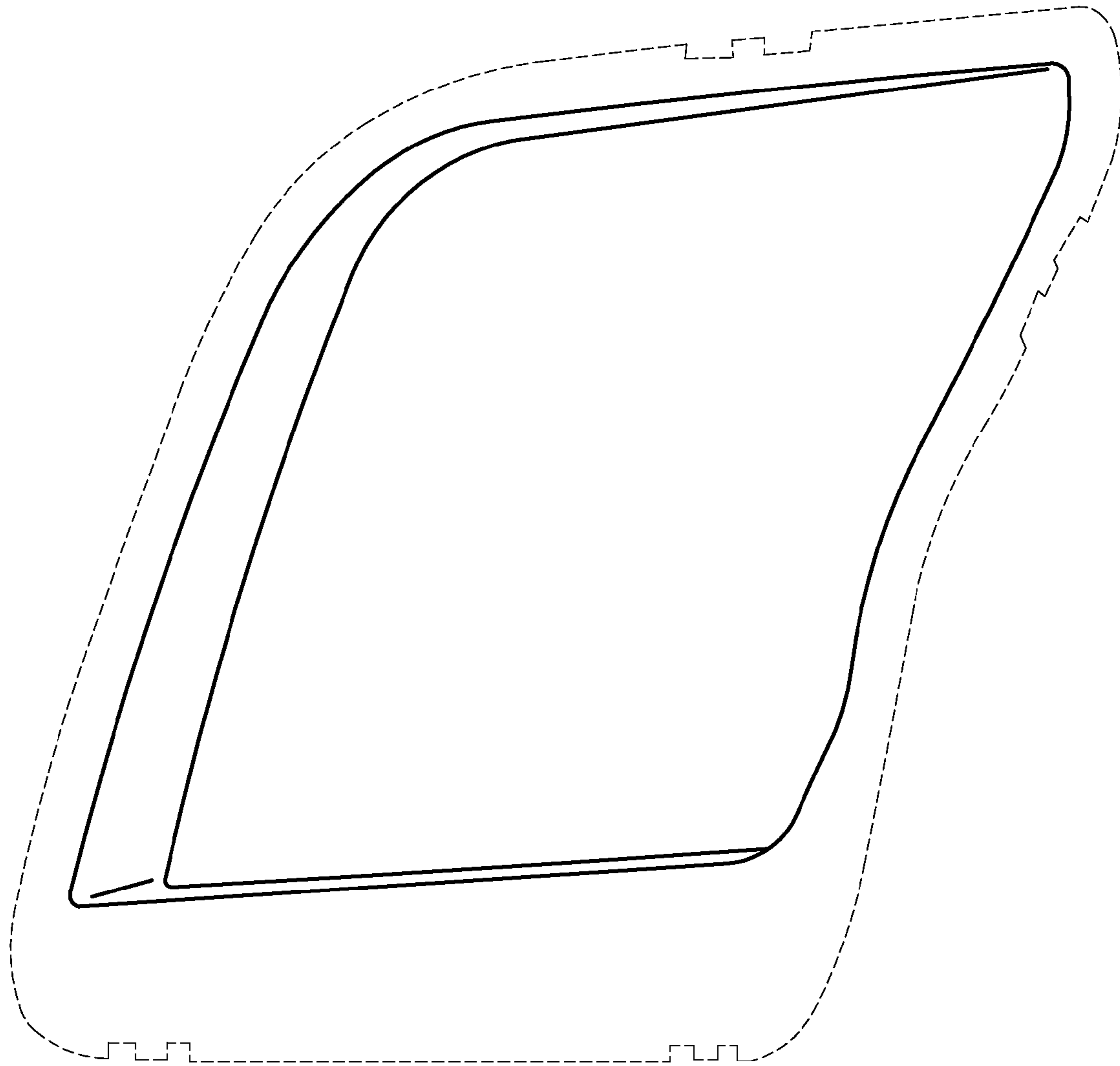
**FIG - 10**



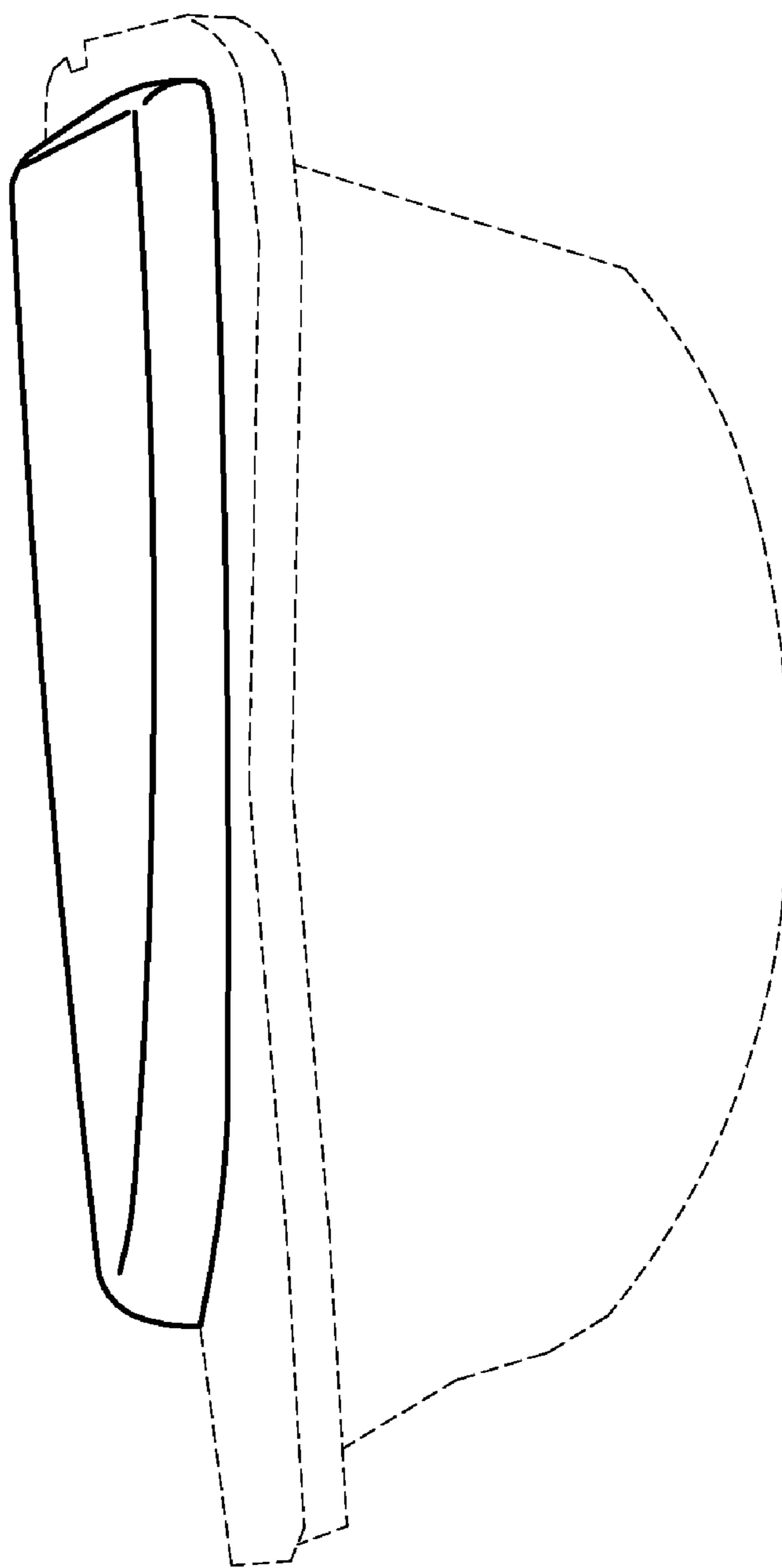
**FIG - 11**



**FIG - 12**



**FIG - 13**



**FIG - 14**