



US00D559412S

(12) **United States Design Patent**
Schiavone et al.

(10) **Patent No.:** **US D559,412 S**
(45) **Date of Patent:** **** Jan. 8, 2008**

(54) **AUTOMOBILE HEADLIGHT LENS**

(75) Inventors: **Patrick Schiavone**, Birmingham, MI (US); **Craig Metros**, Bloomfield, MI (US); **Jeffrey Nowak**, Huntington Woods, MI (US); **Shawn Yu**, Northville, MI (US); **James Smith**, Royal Oak, MI (US); **Ryan Niemiec**, Livonia, MI (US)

(73) Assignee: **Ford Global Technologies, LLC**, Dearborn, MI (US)

(**) Term: **14 Years**

(21) Appl. No.: **29/240,521**

(22) Filed: **Oct. 14, 2005**

(51) **LOC (8) Cl.** **26-06**

(52) **U.S. Cl.** **D26/28**

(58) **Field of Classification Search** D26/28-36;
362/459-468, 475-478, 485-487

See application file for complete search history.

(56) **References Cited**

U.S. PATENT DOCUMENTS

D535,763 S *	1/2007	Pfeiffer	D26/28
D536,113 S *	1/2007	Pfeiffer	D26/28
D537,180 S *	2/2007	Hsu	D26/28
D540,482 S *	4/2007	Miwa et al.	D26/28
D541,445 S *	4/2007	Lin	D26/28
D546,486 S *	7/2007	Sinkwitz et al.	D26/28

OTHER PUBLICATIONS

TheCarConnection.com, Future Cars: Ford/PAG/Mazda: *FORD*, May 16, 2005, http://www.thecarconnection.com/Shoppers/Future_Cars/Ford.S283.A8367.html.

Edmunds.com, Future Vehicles: Spy Shots: 2007 Ford Everest: *New Ford Full-Size SUV Coming Next Year*, Jun. 9, 2005, <http://www.edmunds.com/insideline/do/Features/articleId=105986#3>.

AutoBlog, *Ford Everest spied*, Jun. 10, 2005, <http://spypictures.autoblog.com/entry/1234000260046266/>.

* cited by examiner

Primary Examiner—Marcus A. Jackson

(74) *Attorney, Agent, or Firm*—Damian Porcari

(57) **CLAIM**

The ornamental design for an automobile headlight lens, as shown and described.

DESCRIPTION

FIG. 1 is a frontal perspective view of a left automobile headlight lens attached to a vehicle, no part of the vehicle is claimed;

FIG. 2 is a perspective view of the left automobile headlight lens;

FIG. 3 is a front elevational view of the left automobile headlight lens;

FIG. 4 is a left side elevational view of the left automobile headlight lens;

FIG. 5 is a top plan view of the left automobile headlight lens;

FIG. 6 is a bottom plan view of the left automobile headlight lens;

FIG. 7 is a front elevation view of a automobile headlight lens illustrated in FIGS. 1-6, showing a right automobile headlight lens, with the automobile shown in broken lines and forming no part of the claimed design;

FIG. 8 is a perspective view of the right automobile headlight lens;

FIG. 9 is a front elevational view of the right automobile headlight lens;

FIG. 10 is a right side elevational view of the right automobile headlight lens;

FIG. 11 is a top plan view of the right automobile headlight lens; and,

FIG. 12 is a bottom plan view of the right automobile headlight lens.

The phantom lines are not a part of the claimed invention.

1 Claim, 12 Drawing Sheets

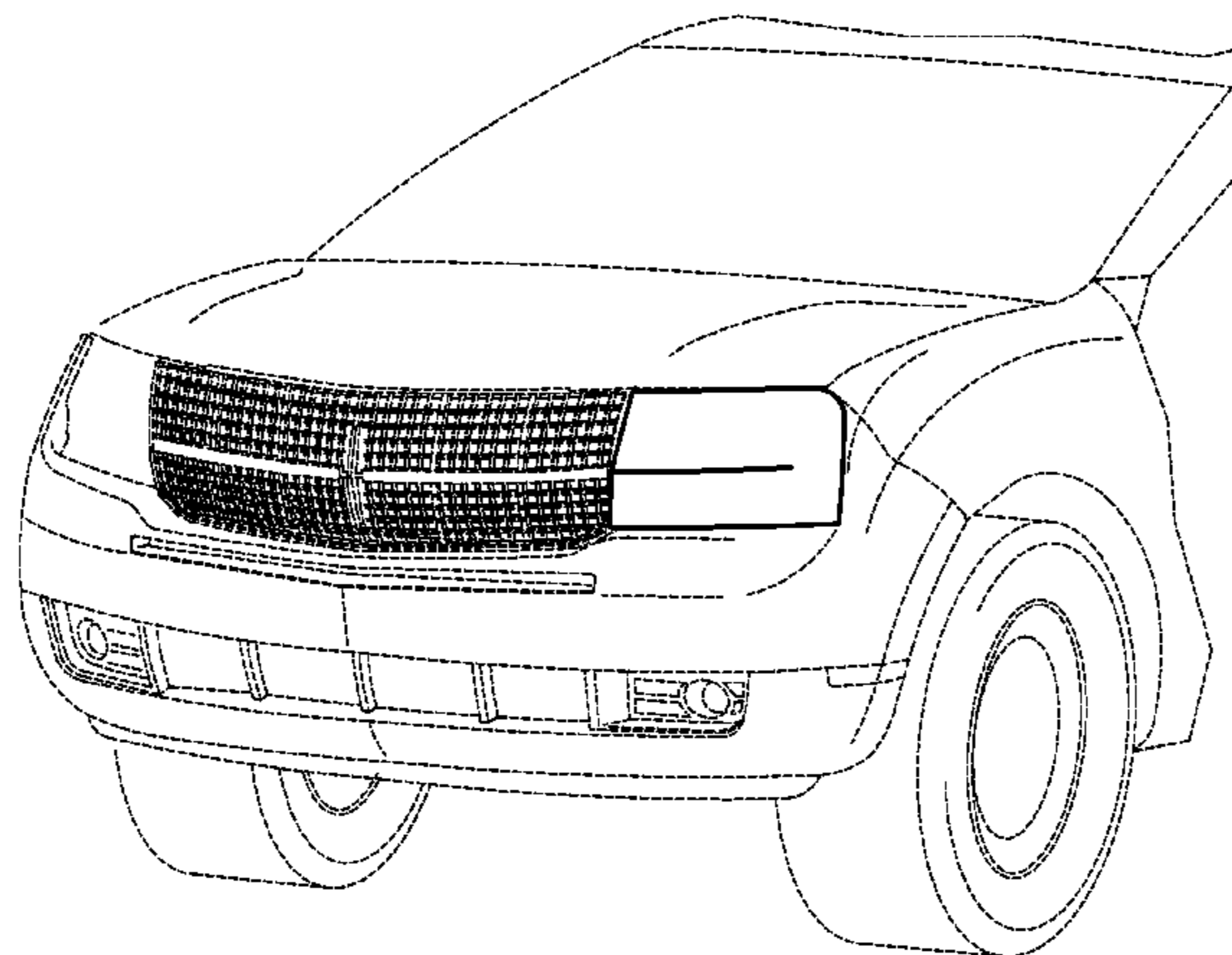

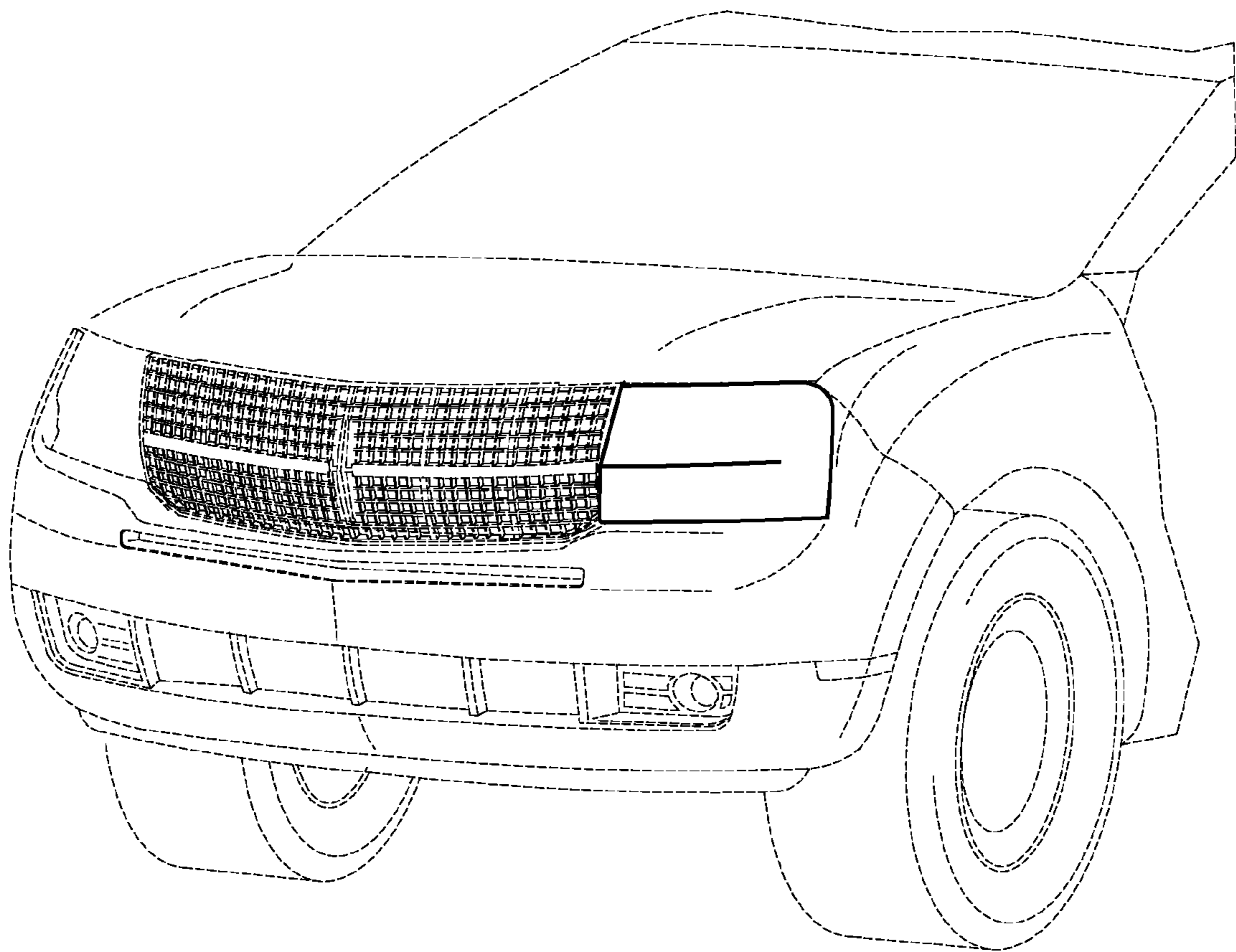

FIG - 1

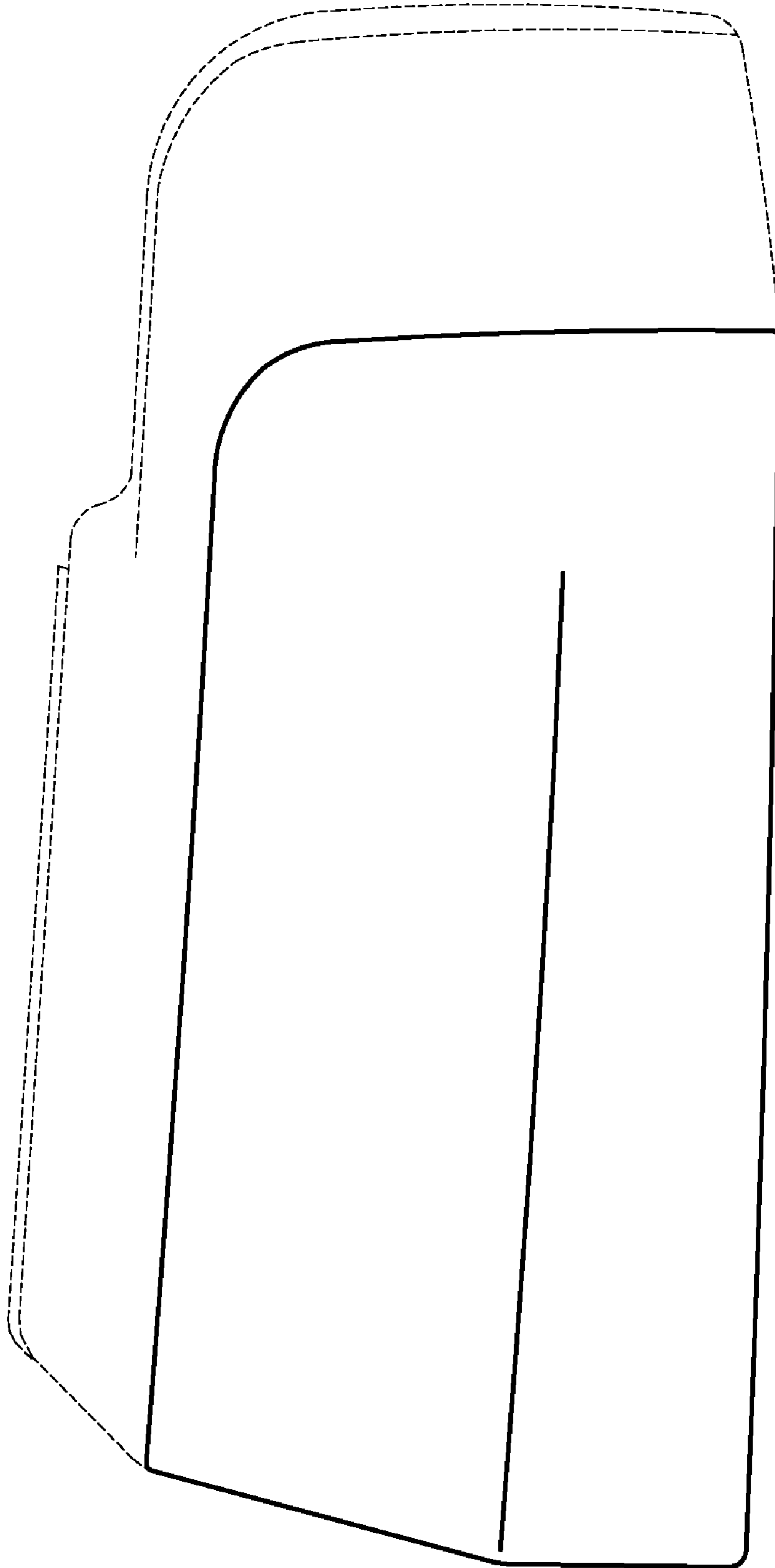

FIG - 2

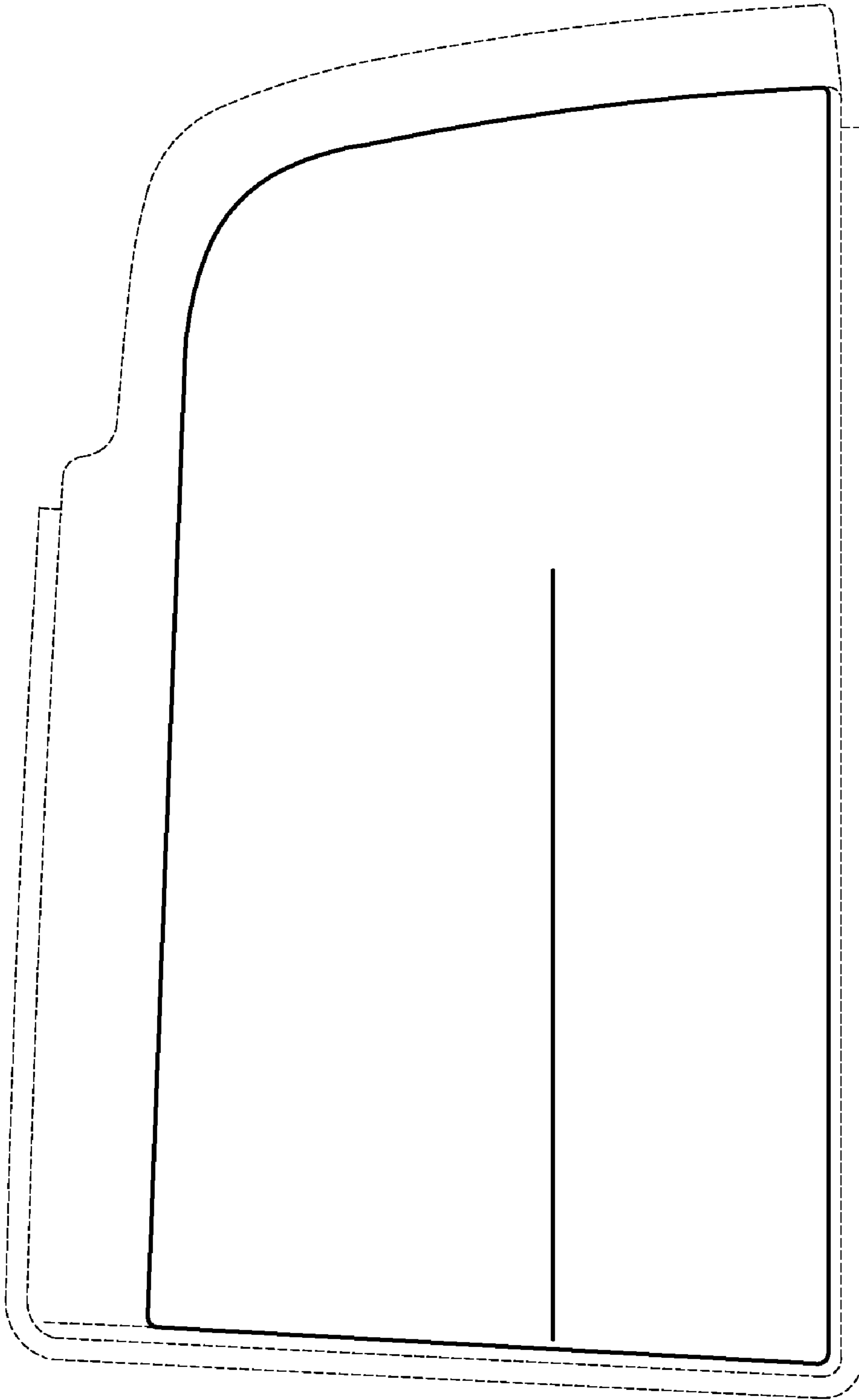

FIG - 3

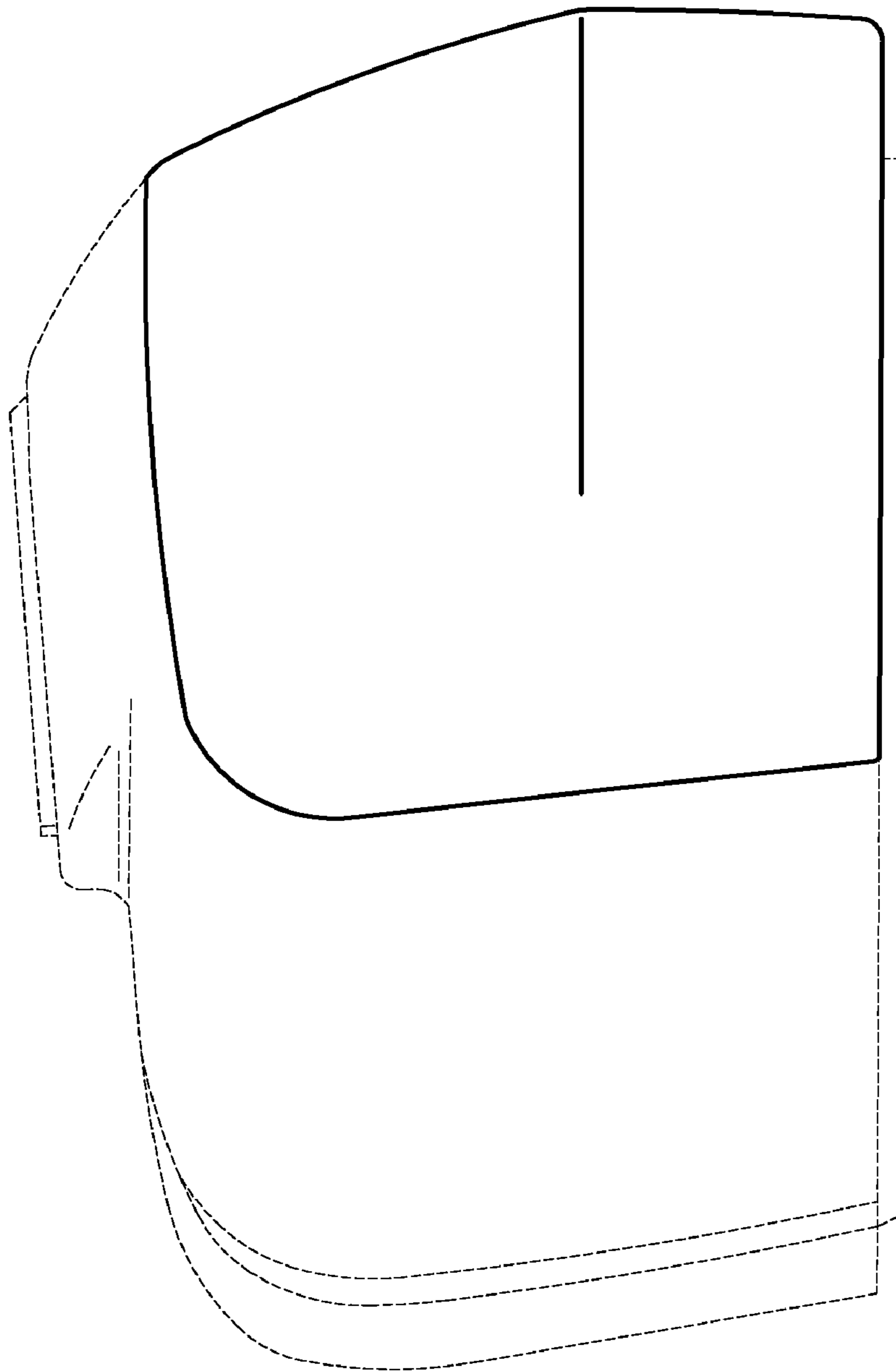

FIG - 4

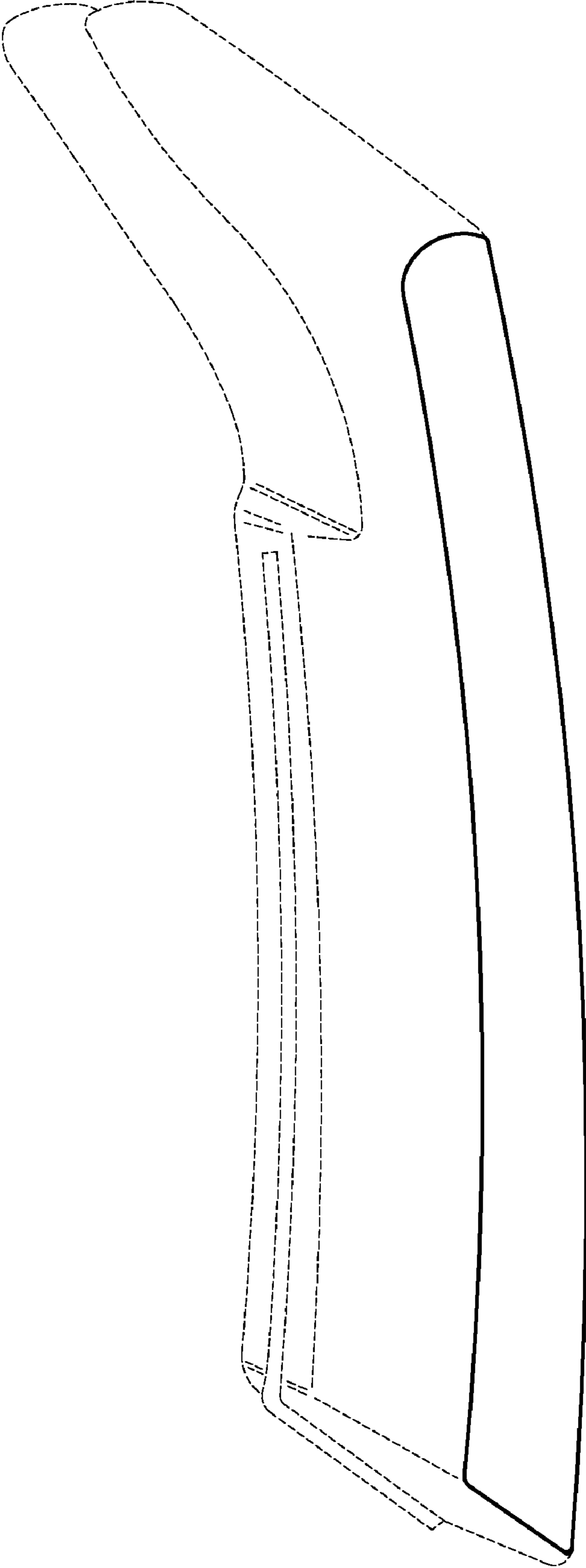

FIG - 5

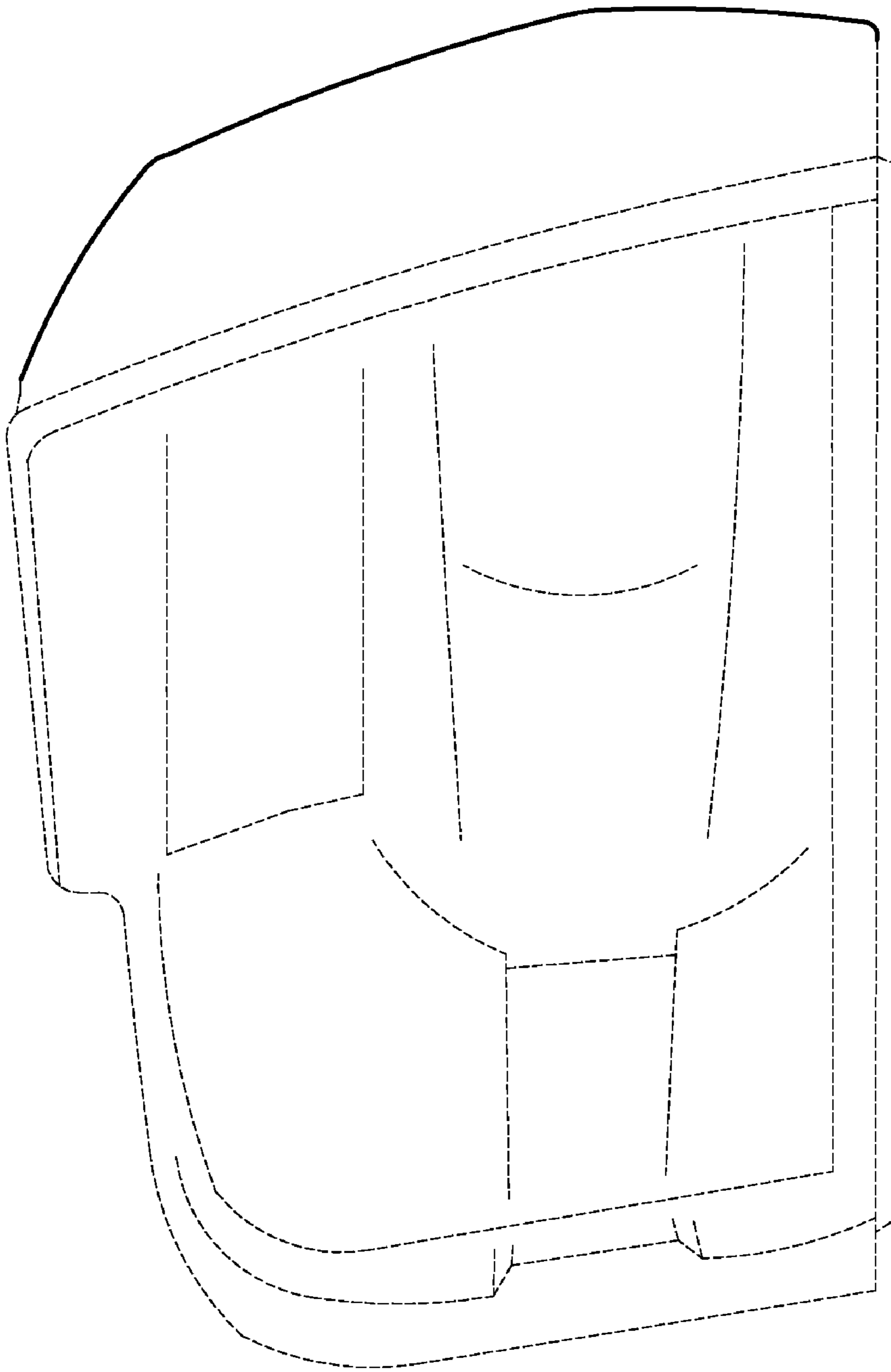

FIG - 6

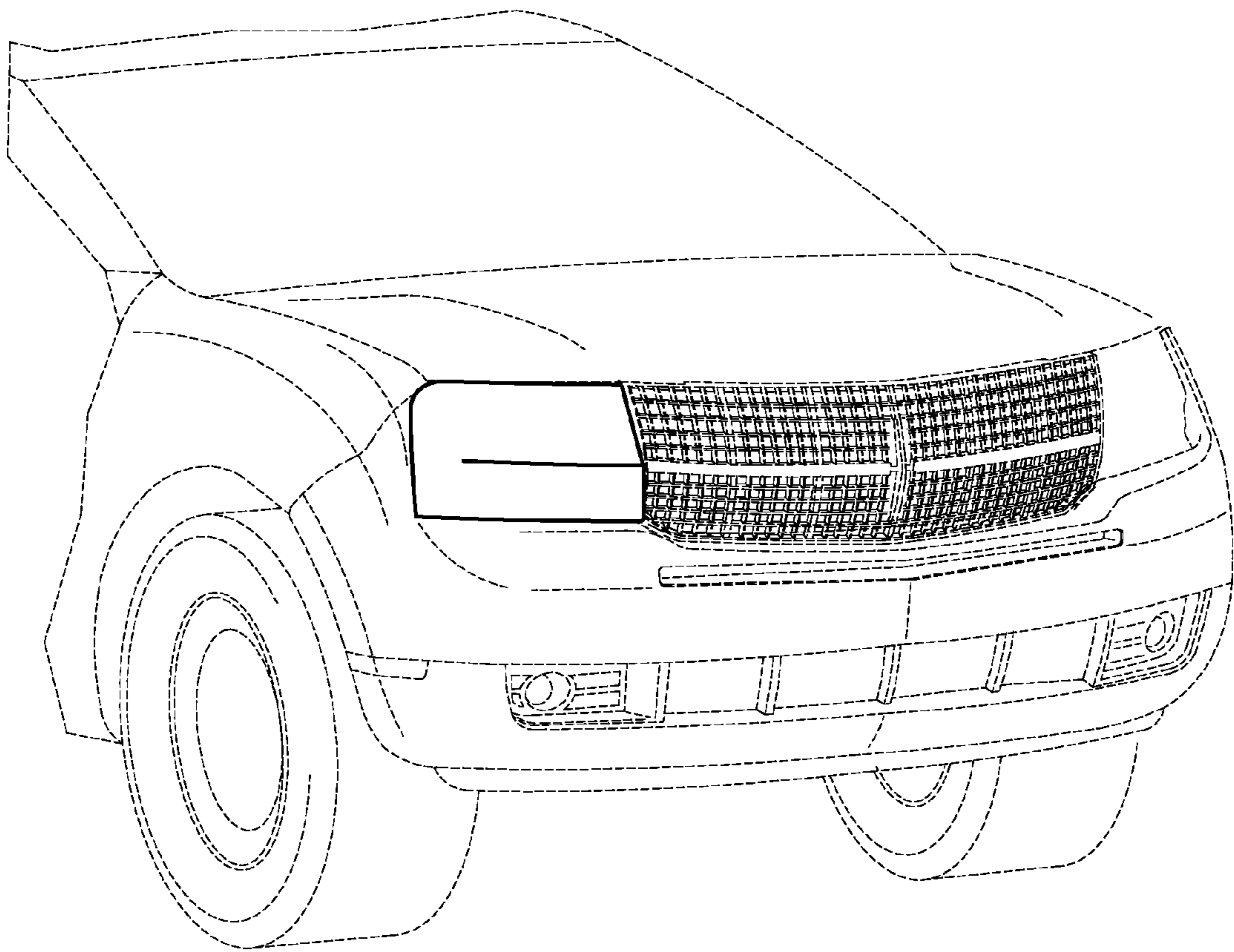

FIG - 7

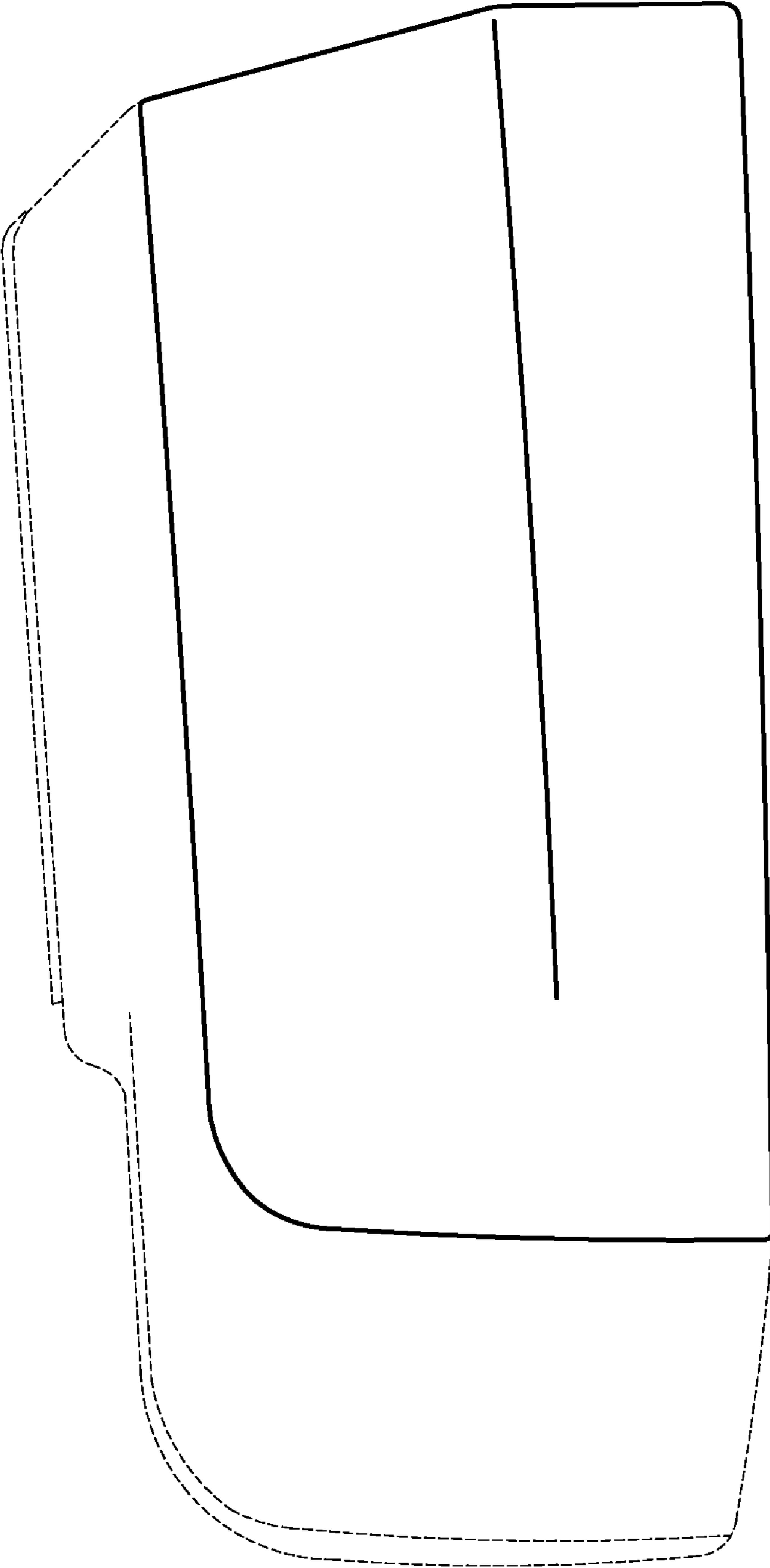

FIG - 8

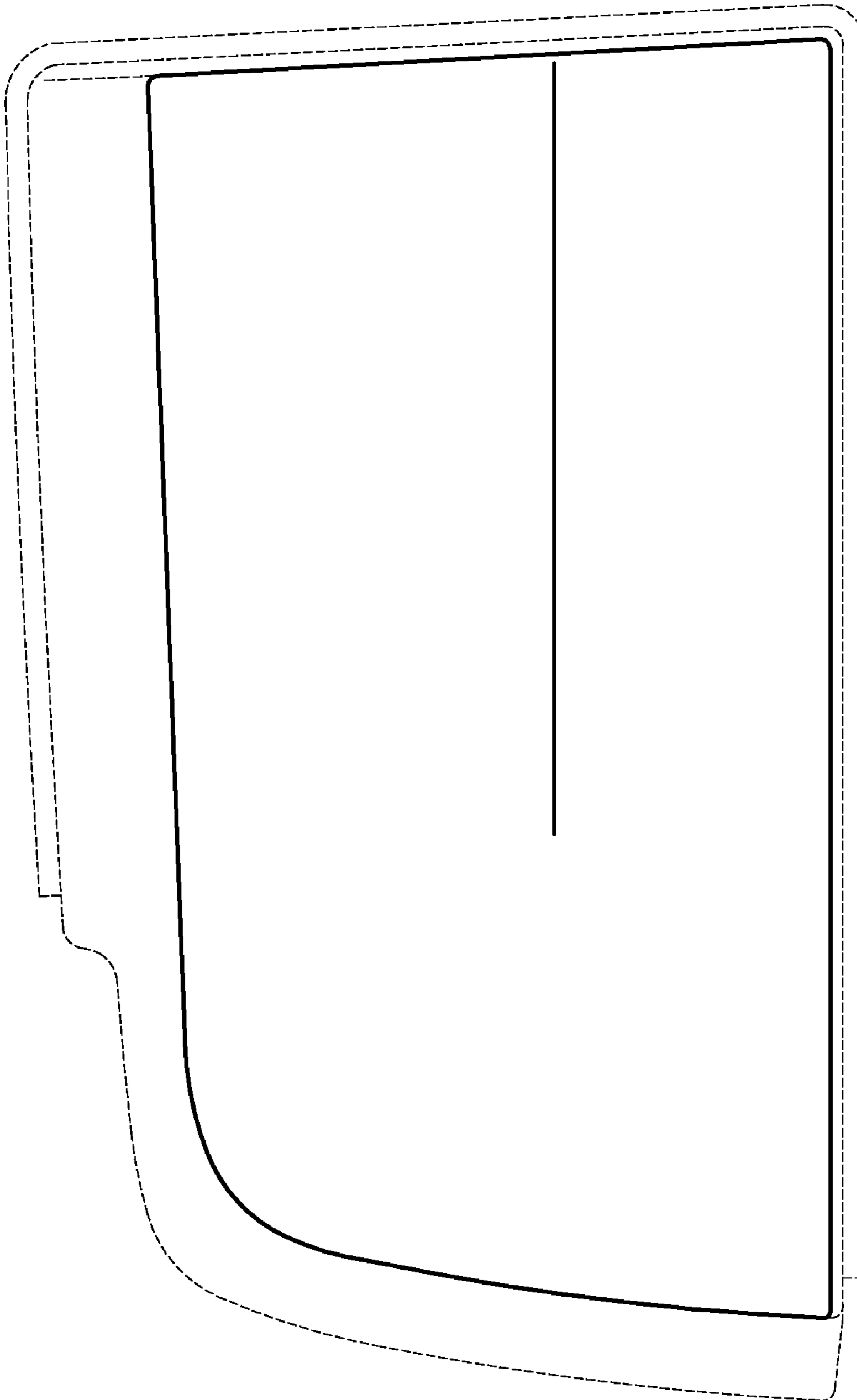

FIG - 9

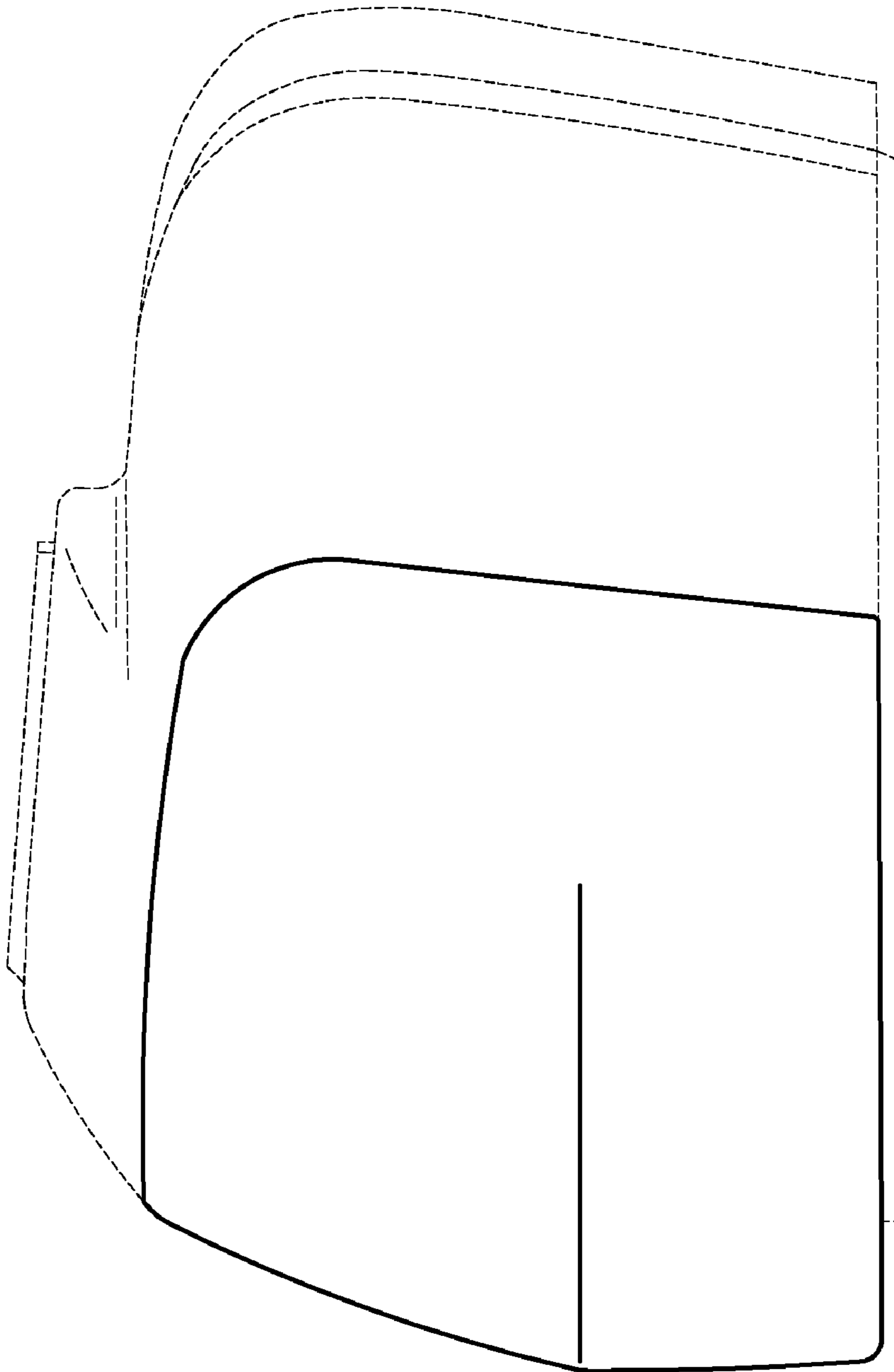

FIG - 10

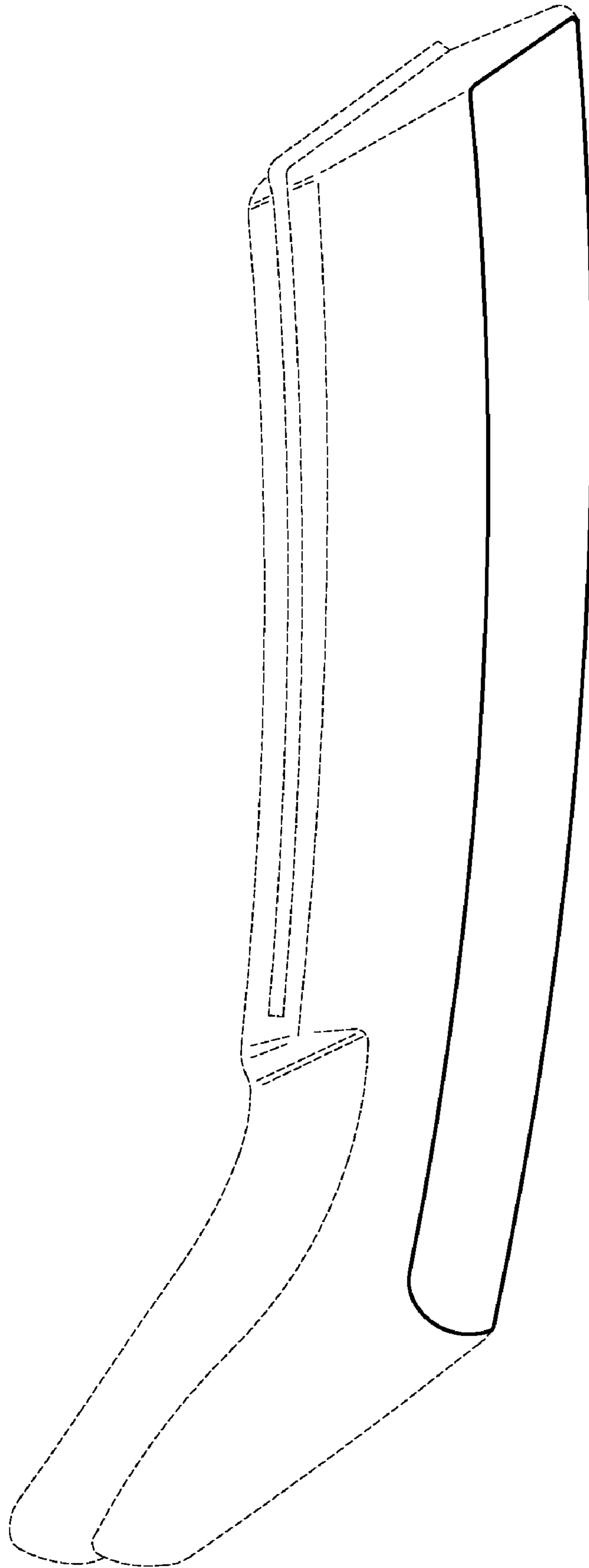

FIG - 11

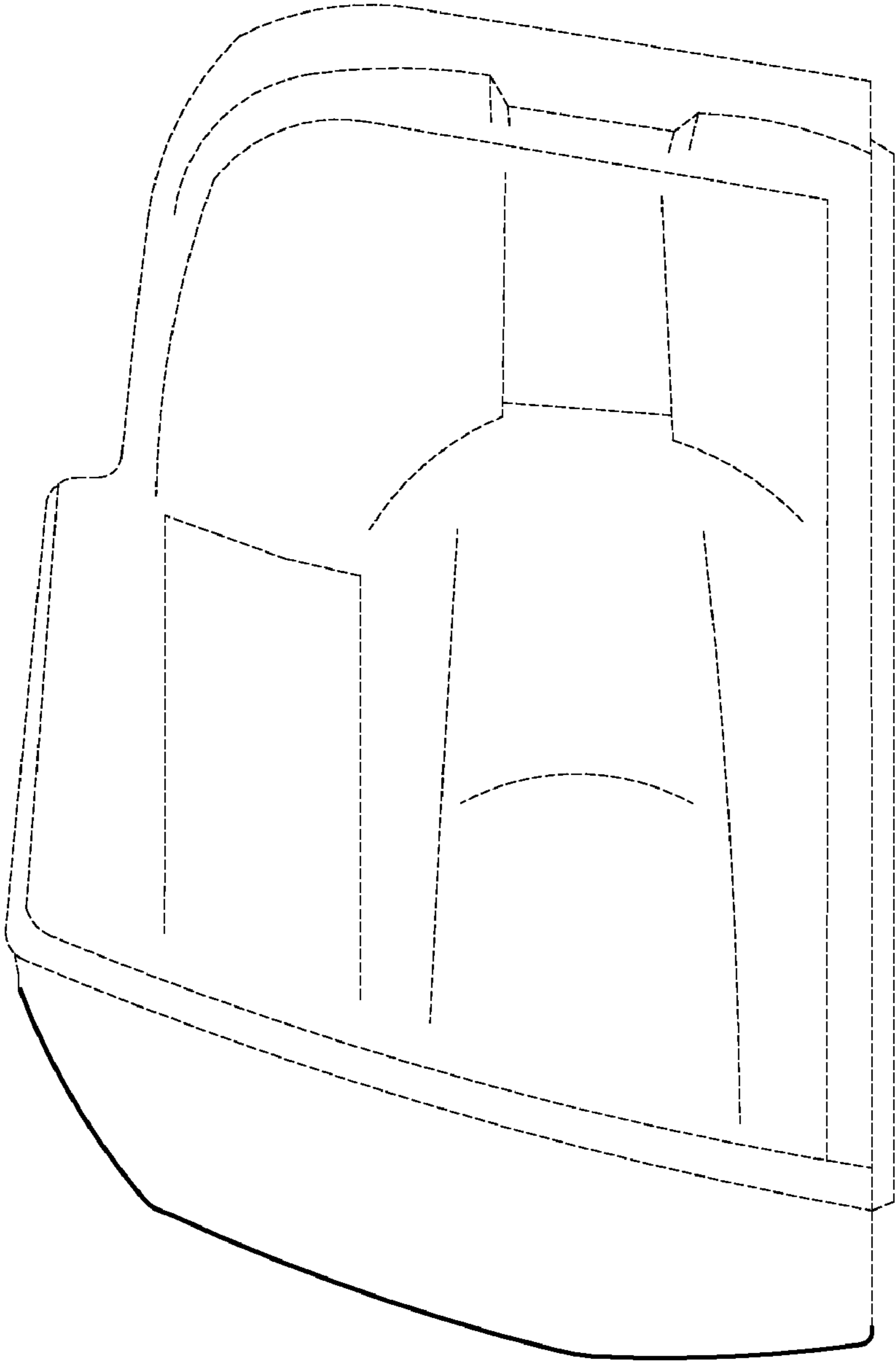

FIG - 12