



US00D559278S

(12) **United States Design Patent**  
**Tsujita et al.**

(10) **Patent No.:** **US D559,278 S**  
(45) **Date of Patent:** **\*\* Jan. 8, 2008**

(54) **TRACTOR**

(75) Inventors: **Masafumi Tsujita**, Osaka (JP); **Takashi Komaki**, Osaka (JP); **Kazuhisa Yokoyama**, Osaka (JP); **Yumiko Yamashita**, Osaka (JP); **Yoshiharu Kouchi**, Osaka (JP)

(73) Assignee: **Yanmar Co., Ltd.**, Osaka (JP)

(\*\*) Term: **14 Years**

(21) Appl. No.: **29/276,617**

(22) Filed: **Jan. 30, 2007**

(51) **LOC (8) Cl.** ..... **12-09**

(52) **U.S. Cl.** ..... **D15/24; D15/26**

(58) **Field of Classification Search** ..... D15/10,  
D15/14, 15, 22-26, 31, 33; 180/89.1, 89.12,  
180/900; 56/16.7, 202, 255-257  
See application file for complete search history.

(56) **References Cited**

**U.S. PATENT DOCUMENTS**

- D247,624 S \* 3/1978 Emundts et al. .... D15/23
- D256,017 S \* 7/1980 Emundts et al. .... D15/23
- D302,276 S \* 7/1989 Briggs et al. .... D15/24
- D314,388 S \* 2/1991 Brewer et al. .... D15/24
- 5,018,591 A \* 5/1991 Price ..... 180/9.5
- D364,879 S \* 12/1995 Bastian et al. .... D15/24
- D375,506 S \* 11/1996 Bastian et al. .... D15/24
- D387,068 S \* 12/1997 Kato et al. .... D15/23
- D391,581 S \* 3/1998 Kato et al. .... D15/23
- 5,992,260 A 11/1999 Fujiki et al.
- D440,234 S \* 4/2001 Katoh et al. .... D15/23

- D483,043 S 12/2003 Akashima et al.
- D489,381 S \* 5/2004 Mistry et al. .... D15/23
- D498,245 S \* 11/2004 Kuwae et al. .... D15/23
- D499,748 S 12/2004 Komatsu et al.
- D501,487 S \* 2/2005 Katoh et al. .... D15/23
- 6,889,782 B2 5/2005 Komatsu et al.
- 6,913,103 B2 7/2005 Kitasaka et al.
- D513,268 S \* 12/2005 Wang et al. .... D15/23
- 6,991,042 B2 1/2006 Ochi et al.
- D515,105 S \* 2/2006 Wang et al. .... D15/22
- D523,027 S 6/2006 Yamashita et al.
- D529,932 S 10/2006 Yamashita et al.

\* cited by examiner

*Primary Examiner*—Stella M. Reid

*Assistant Examiner*—Mark Goodwin

(74) *Attorney, Agent, or Firm*—Sterne, Kessler, Goldstein & Fox P.L.L.C.

(57) **CLAIM**

The ornamental design for a tractor, as shown and described.

**DESCRIPTION**

FIG. 1 is a perspective view of a tractor showing our new design;

FIG. 2 is a front view thereof

FIG. 3 is a rear view thereof;

FIG. 4 is a left side view thereof;

FIG. 5 is a right side view thereof;

FIG. 6 is a top plan view thereof; and,

FIG. 7 is a bottom plan view thereof.

**1 Claim, 7 Drawing Sheets**

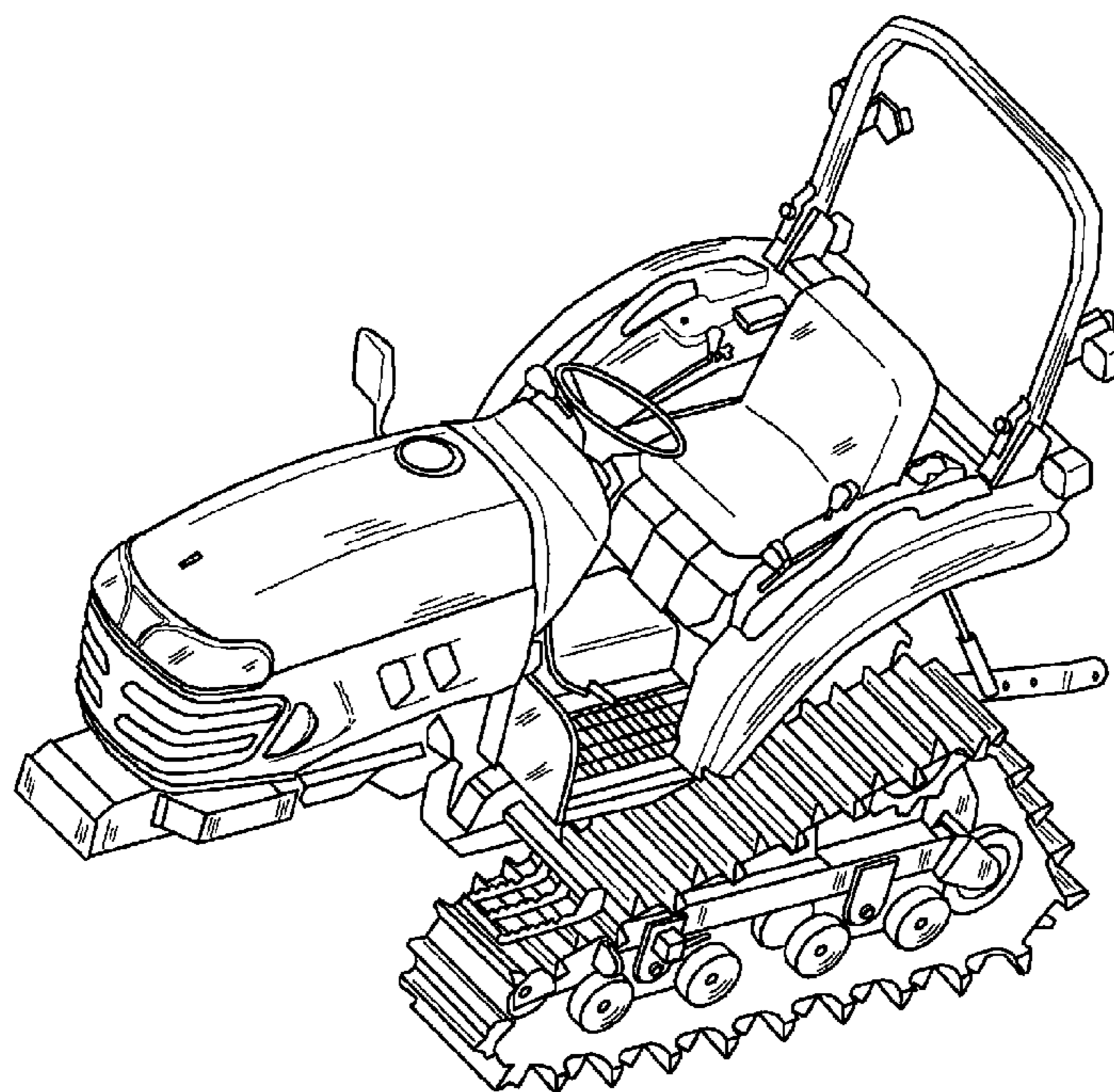

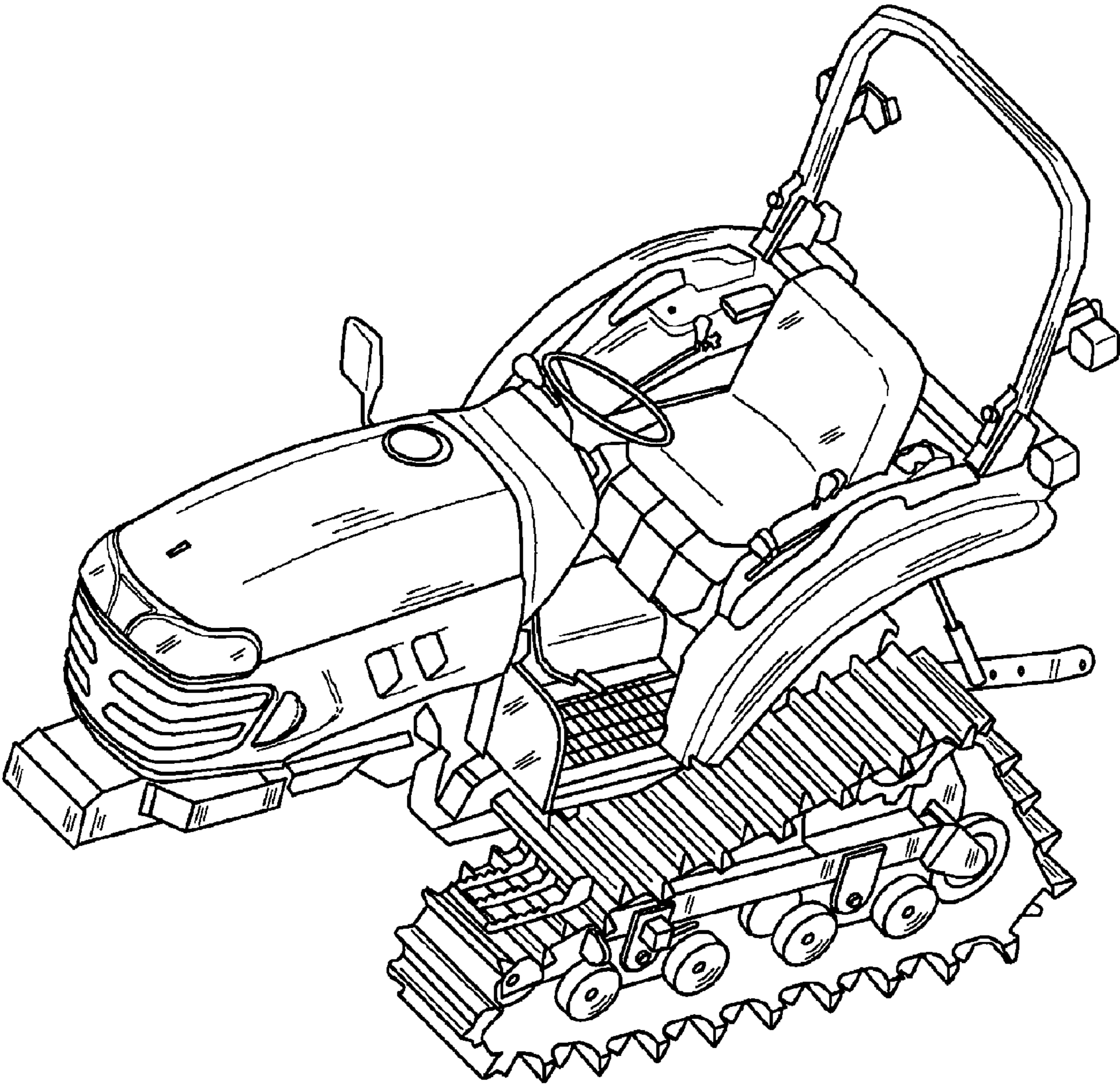

FIG. 1

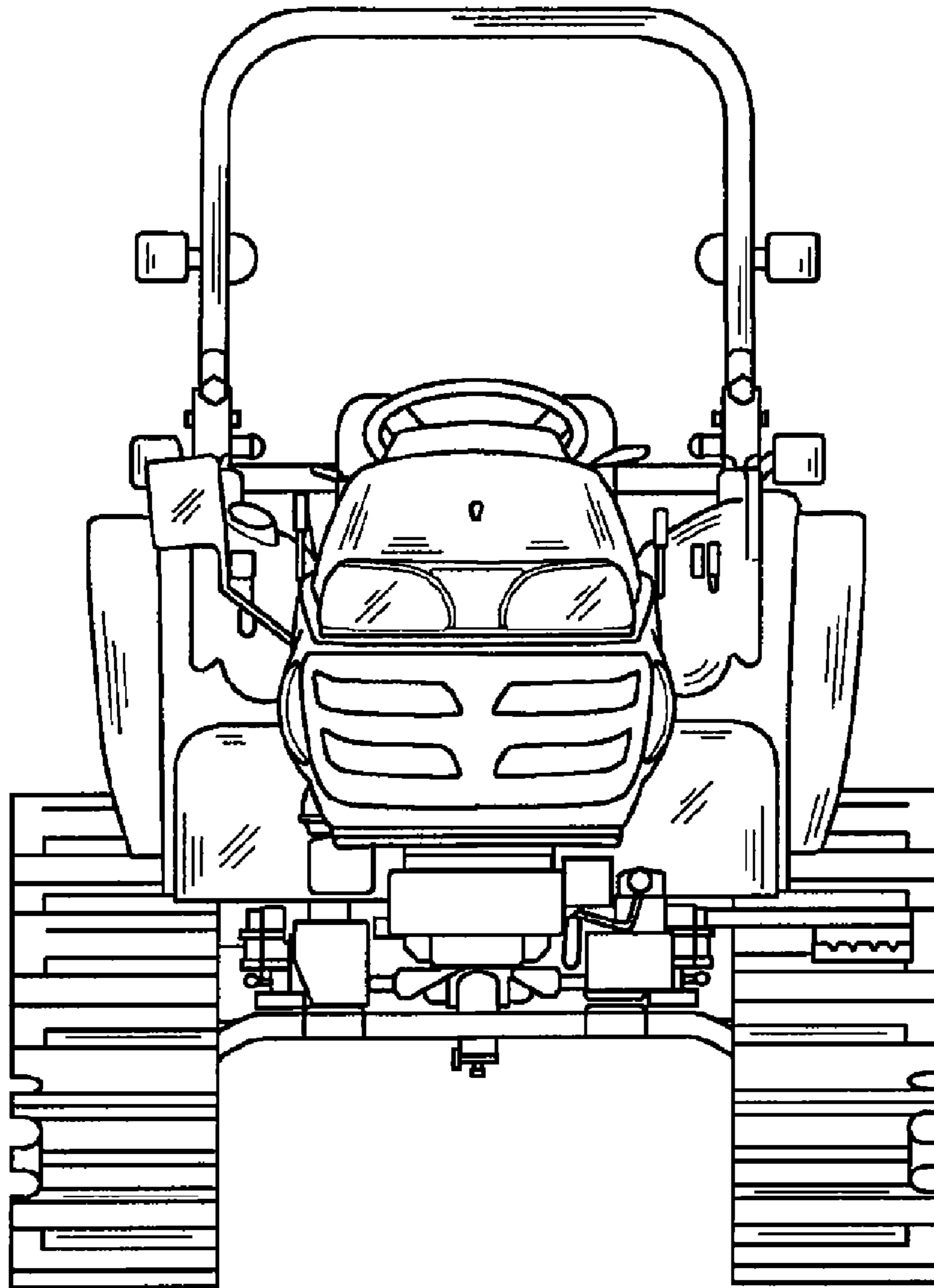

FIG. 2

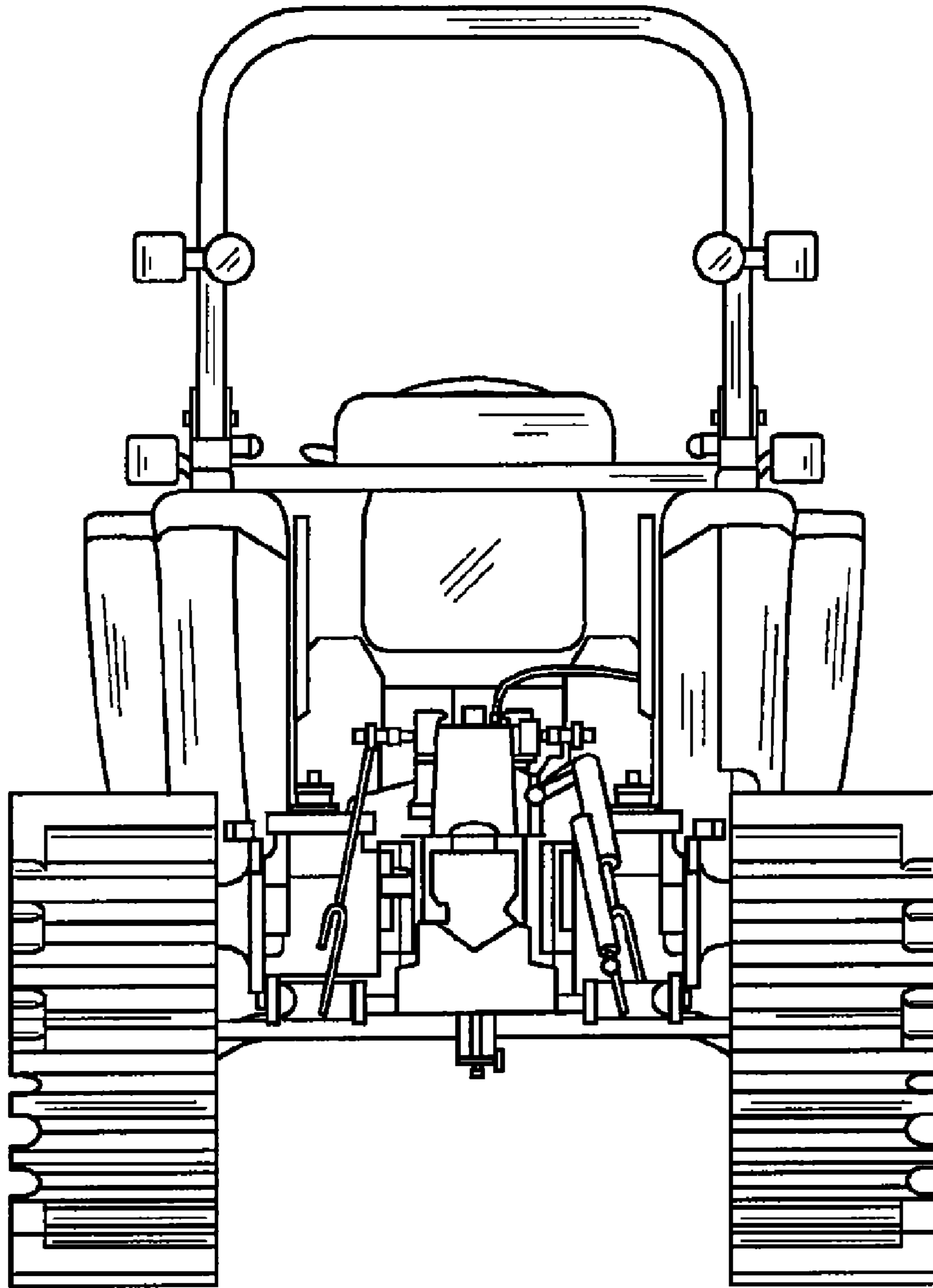

FIG. 3

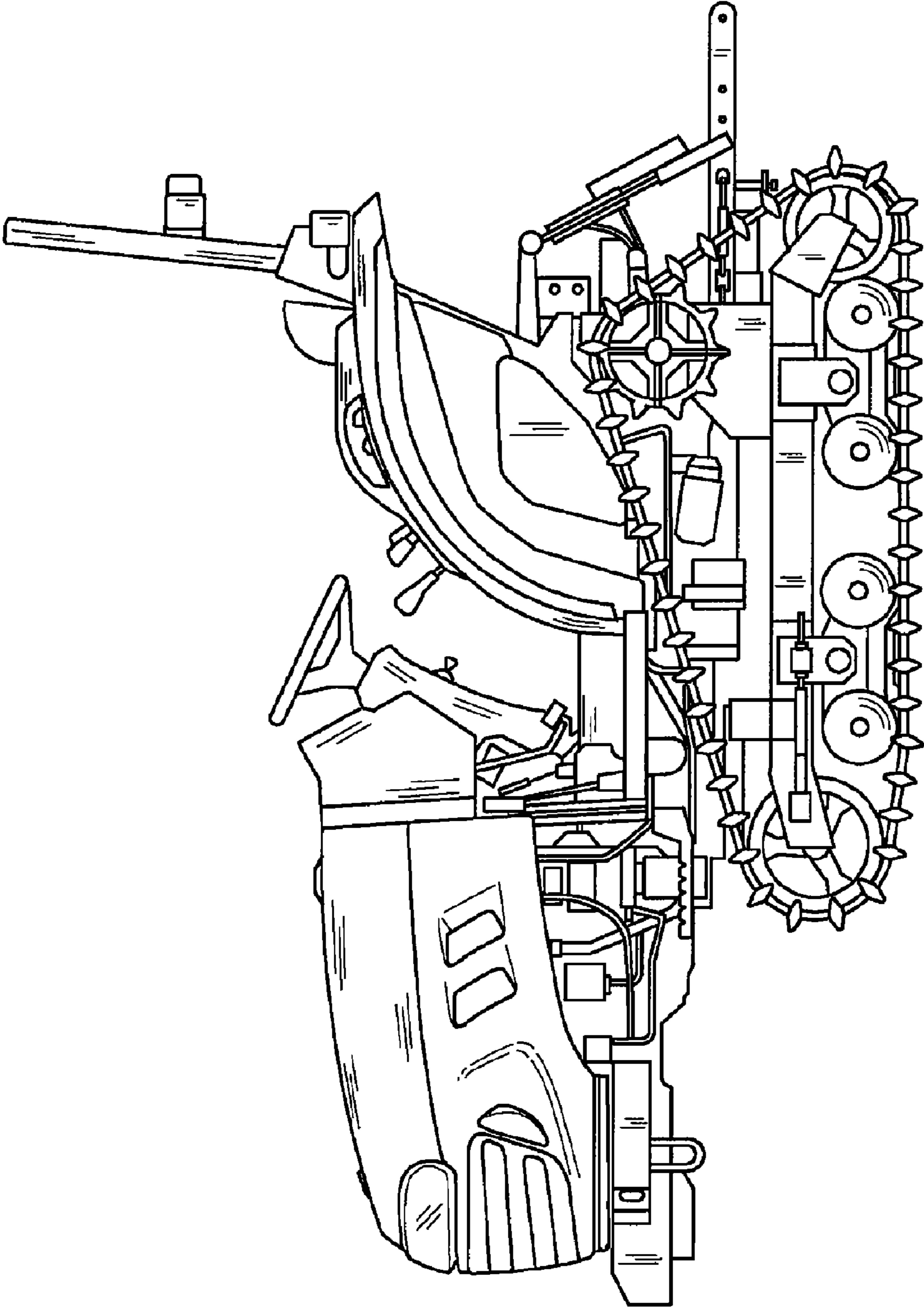

FIG. 4

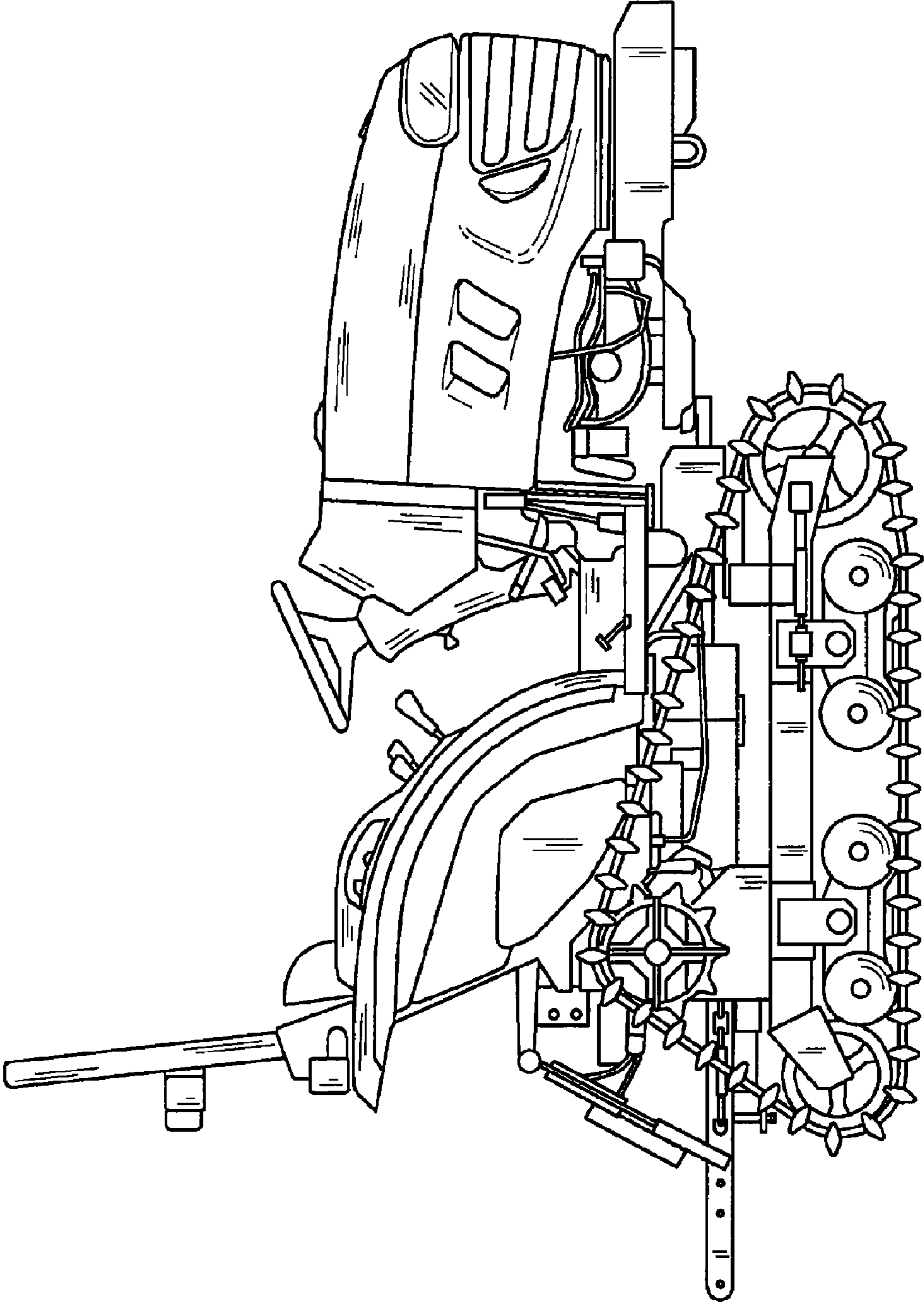

FIG. 5

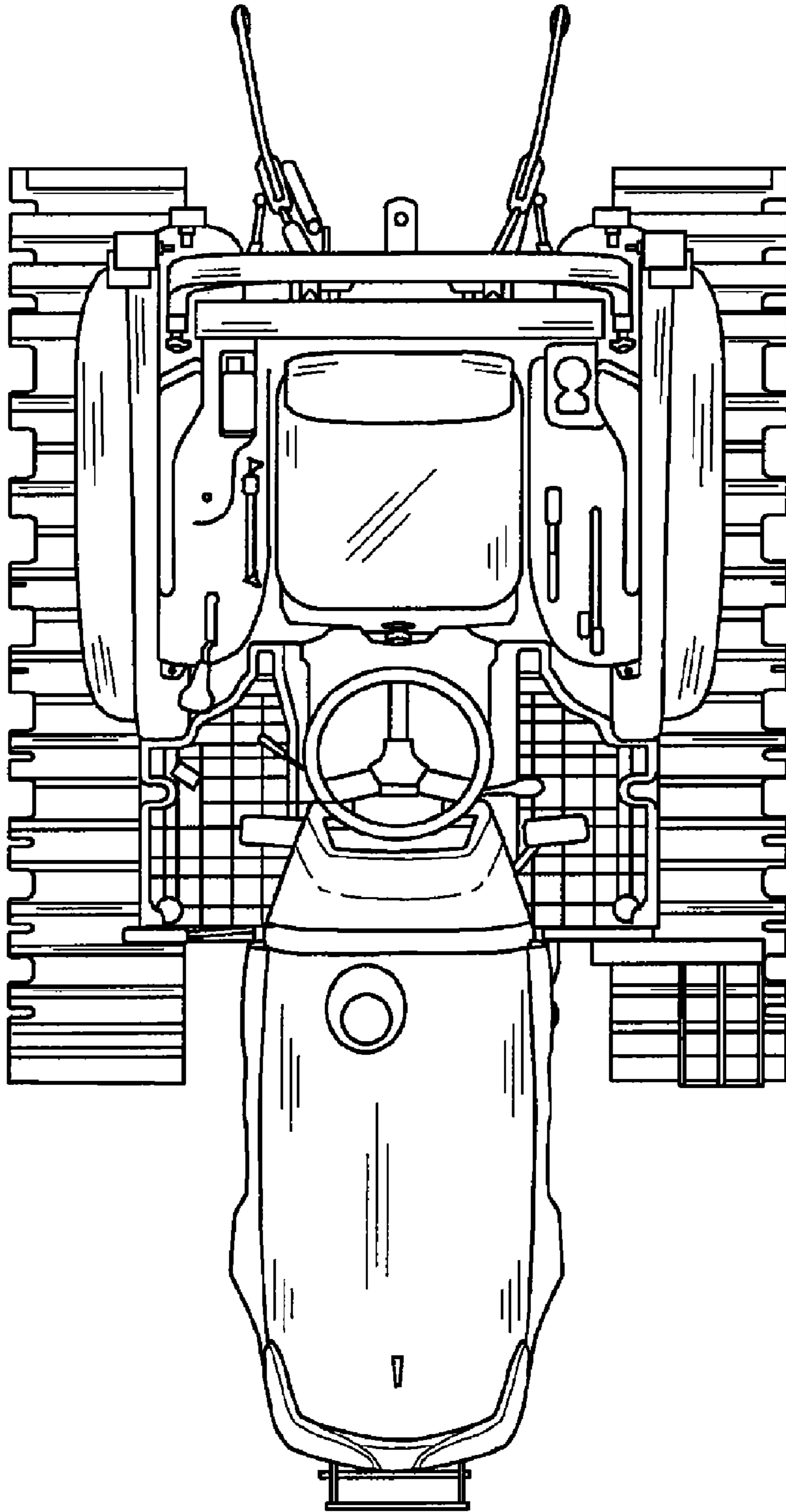

FIG. 6

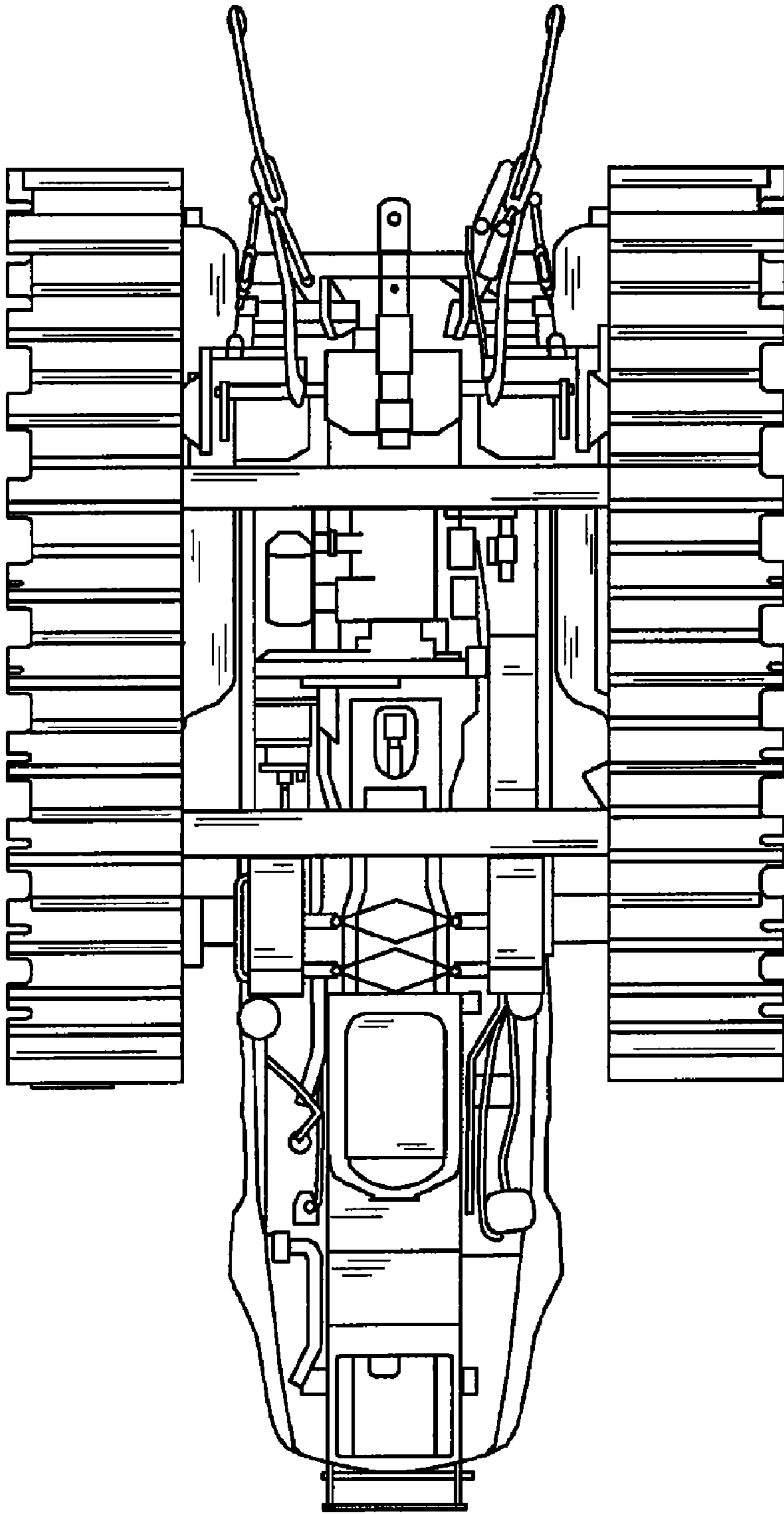

FIG. 7