



US00D559244S

(12) **United States Design Patent**
Fukuda et al.

(10) **Patent No.:** **US D559,244 S**
(45) **Date of Patent:** **** Jan. 8, 2008**

(54) **VEHICLE CONTROL PANEL**

(75) Inventors: **Shunsuke Fukuda**, Nisshin (JP);
Masaki Motozaki, Toyota (JP);
Atsunosuke Tanaka, Aichi-ken (JP)

(73) Assignee: **Toyota Jidosha Kabushiki Kaisha** (JP)

(**) Term: **14 Years**

(21) Appl. No.: **29/271,839**

(22) Filed: **Jan. 26, 2007**

(51) **LOC (8) Cl.** **14-01**

(52) **U.S. Cl.** **D14/258**

(58) **Field of Classification Search** D14/258,
D14/257, 224, 217, 198, 197, 193, 192, 188,
D14/168, 167, 165, 164, 163, 162, 161, 160,
D14/157, 156, 154, 136, 135; 720/691, 658,
720/270; 455/344, 575.1; 396/434, 93;
386/1; 369/93, 75.1; 360/47, 4; 359/550,
359/258; 349/460, 159, 10

See application file for complete search history.

(56) **References Cited**

U.S. PATENT DOCUMENTS

D430,562 S	*	9/2000	Richards	D14/258
D442,571 S	*	5/2001	Nose	D14/157
D512,980 S	*	12/2005	Zuehlsdorff et al.	D14/188
D521,991 S	*	5/2006	Storti et al.	D14/257

OTHER PUBLICATIONS

Mitsubishi, Outlander, <http://www.carview.co.jp>, Available at least as early as Dec. 2005.

Mercedes Benz, M-Class, 2005 North American International Auto Show Press CD, Available at least as early as Dec. 2005.

* cited by examiner

Primary Examiner—Robert M. Spear

Assistant Examiner—Katrina A Kile

(74) *Attorney, Agent, or Firm*—SAIDMAN DesignLaw Group

(57) **CLAIM**

The ornamental design for a vehicle control panel, as shown and described.

DESCRIPTION

FIG. 1 is a front perspective view of a vehicle control panel showing our new design;

FIG. 2 is a front elevational view thereof;

FIG. 3 is a rear elevational view thereof;

FIG. 4 is a top plan view thereof;

FIG. 5 is a bottom plan view thereof;

FIG. 6 is a right side elevational view thereof; and,

FIG. 7 is a left side view thereof.

1 Claim, 5 Drawing Sheets

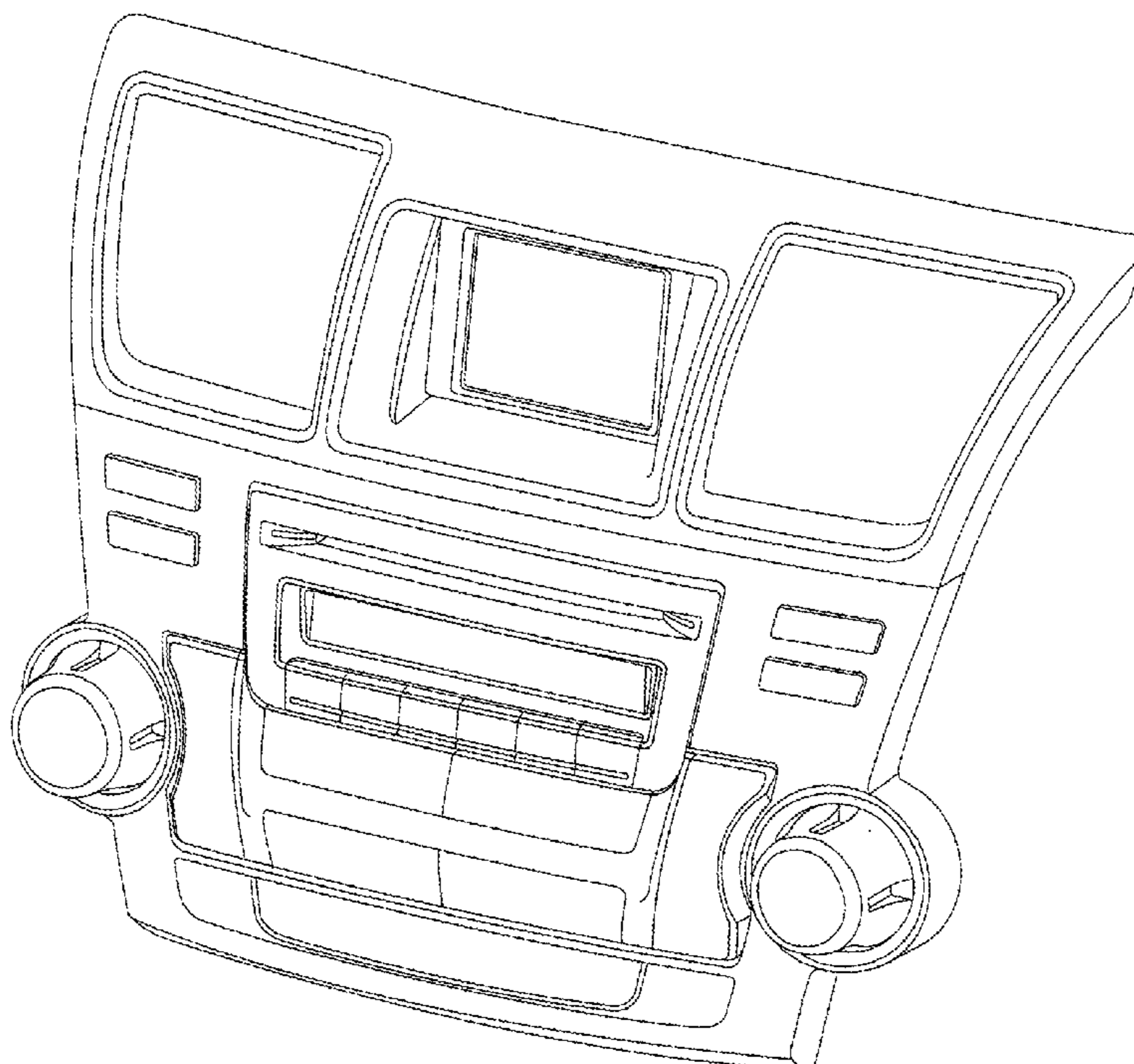

FIG. 1

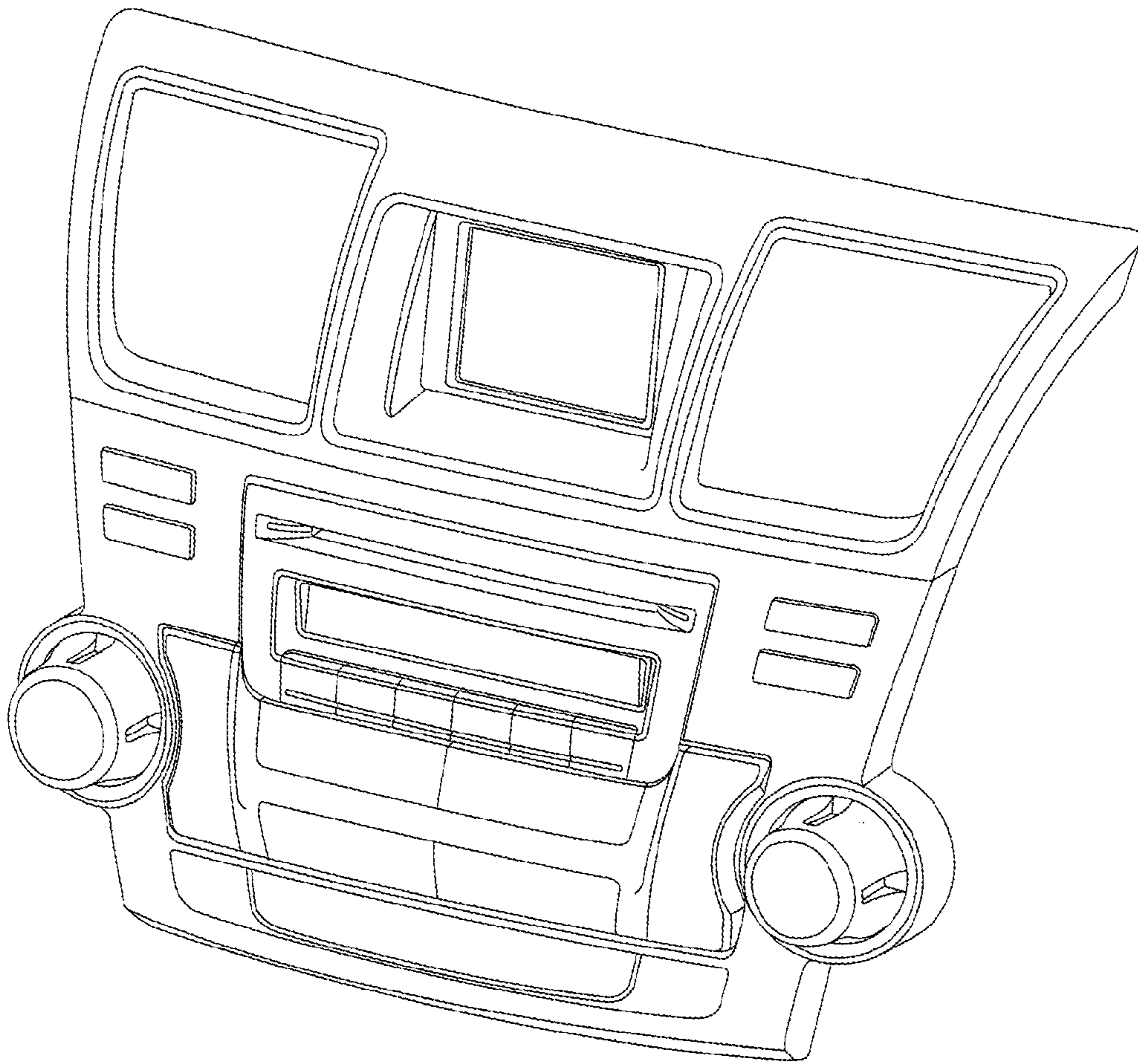

FIG. 2

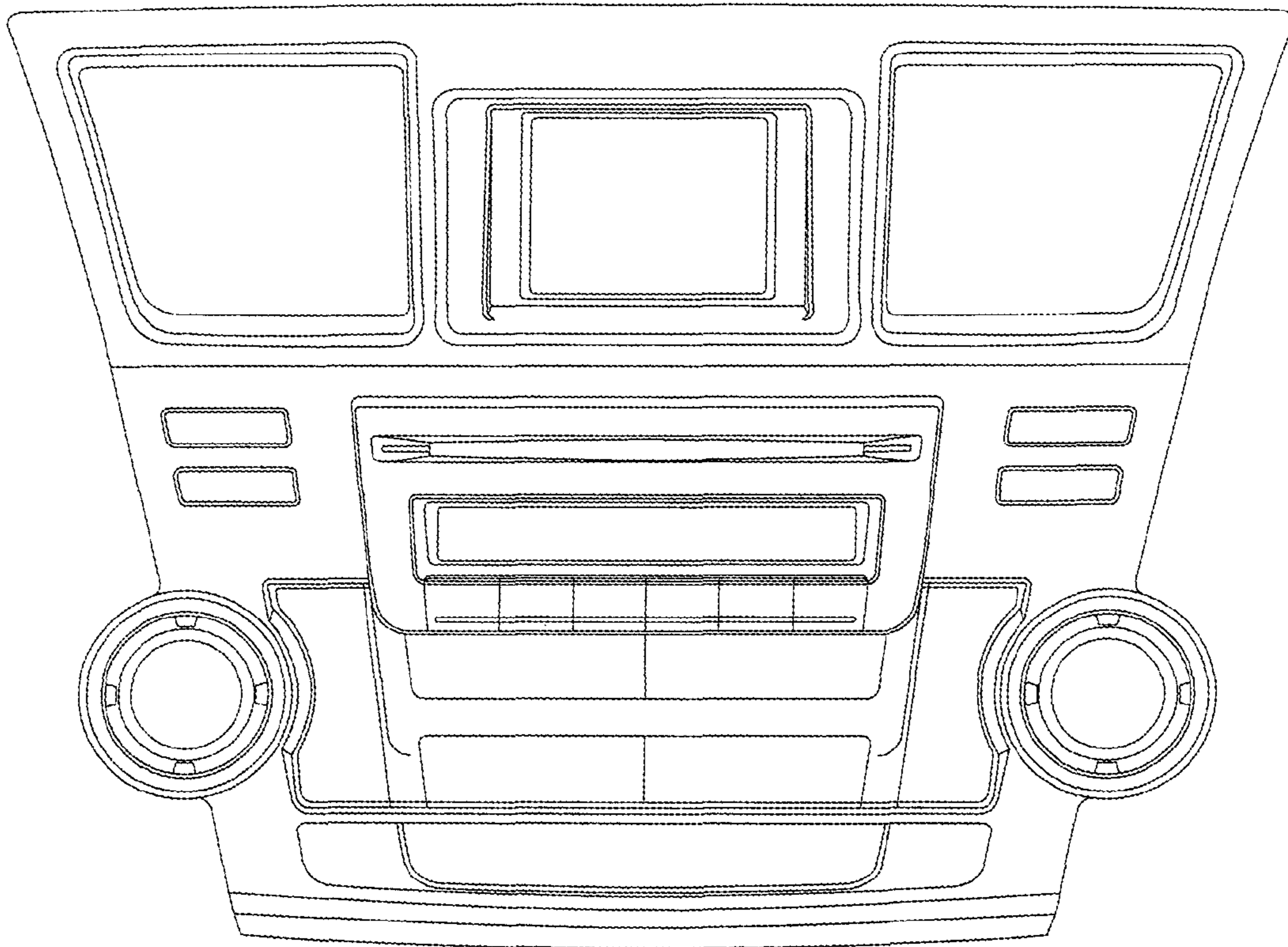

FIG. 3

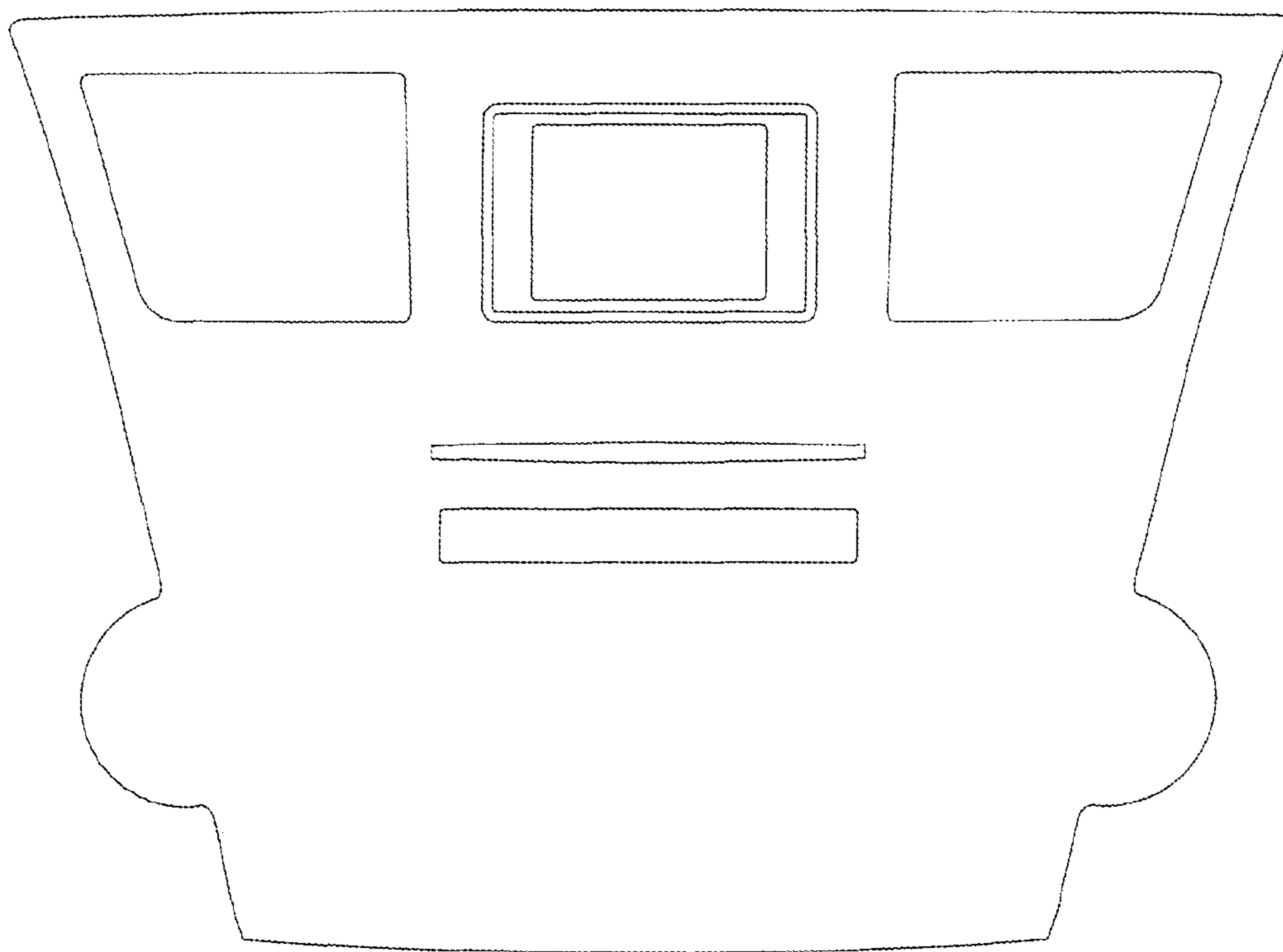

FIG. 4

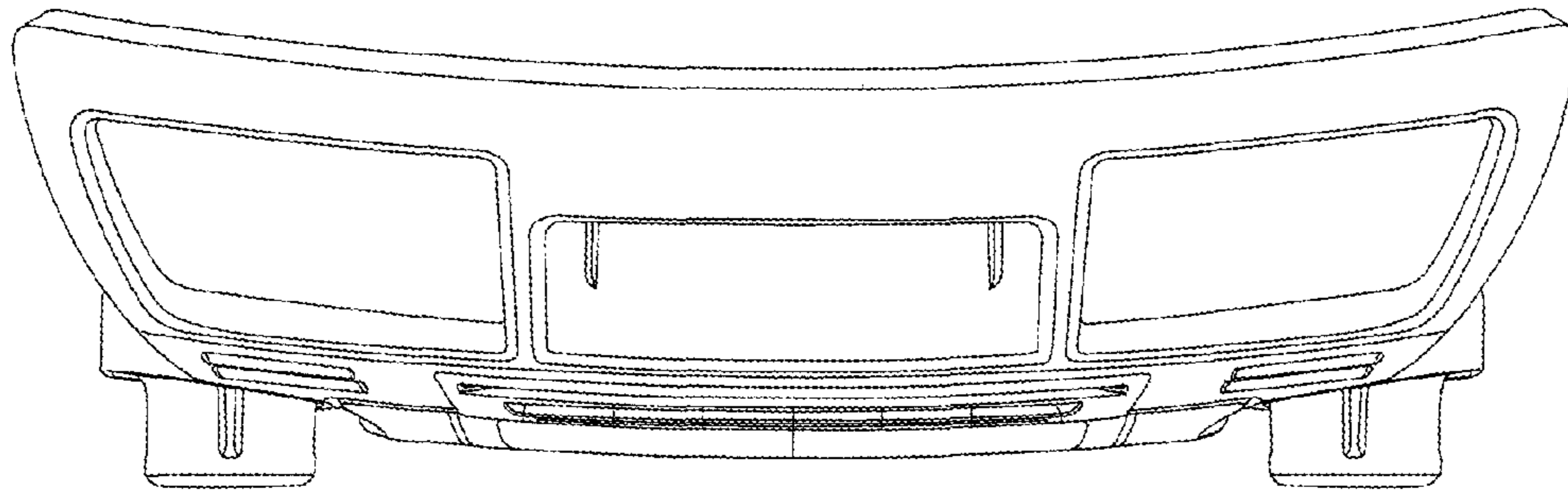

FIG. 5

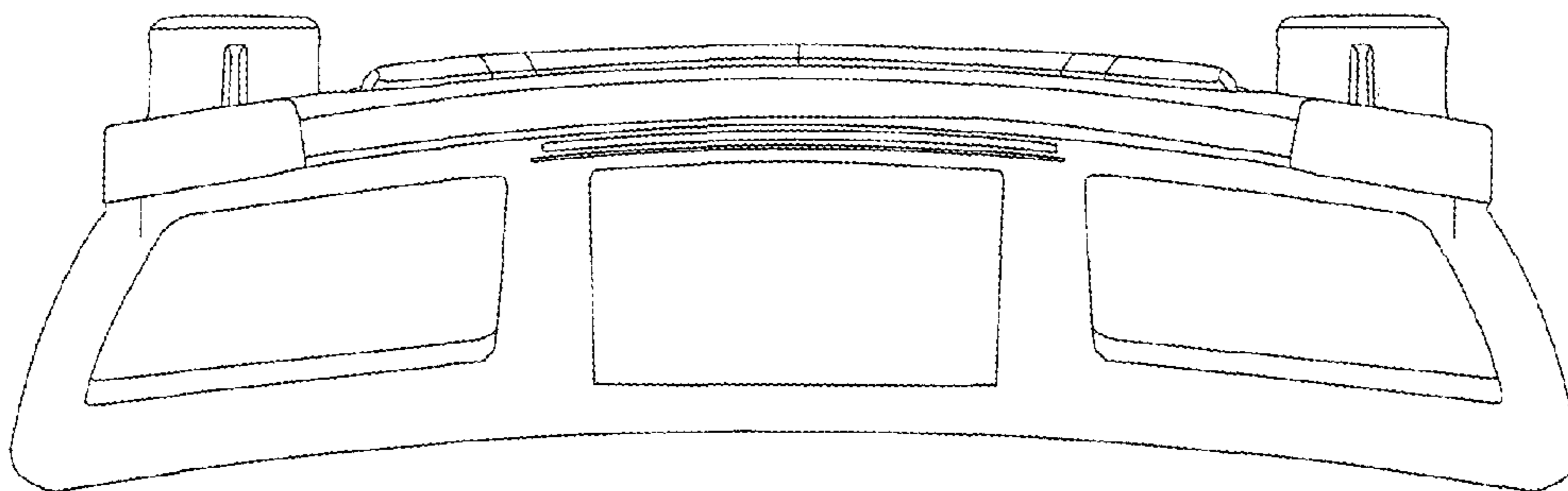

FIG. 6

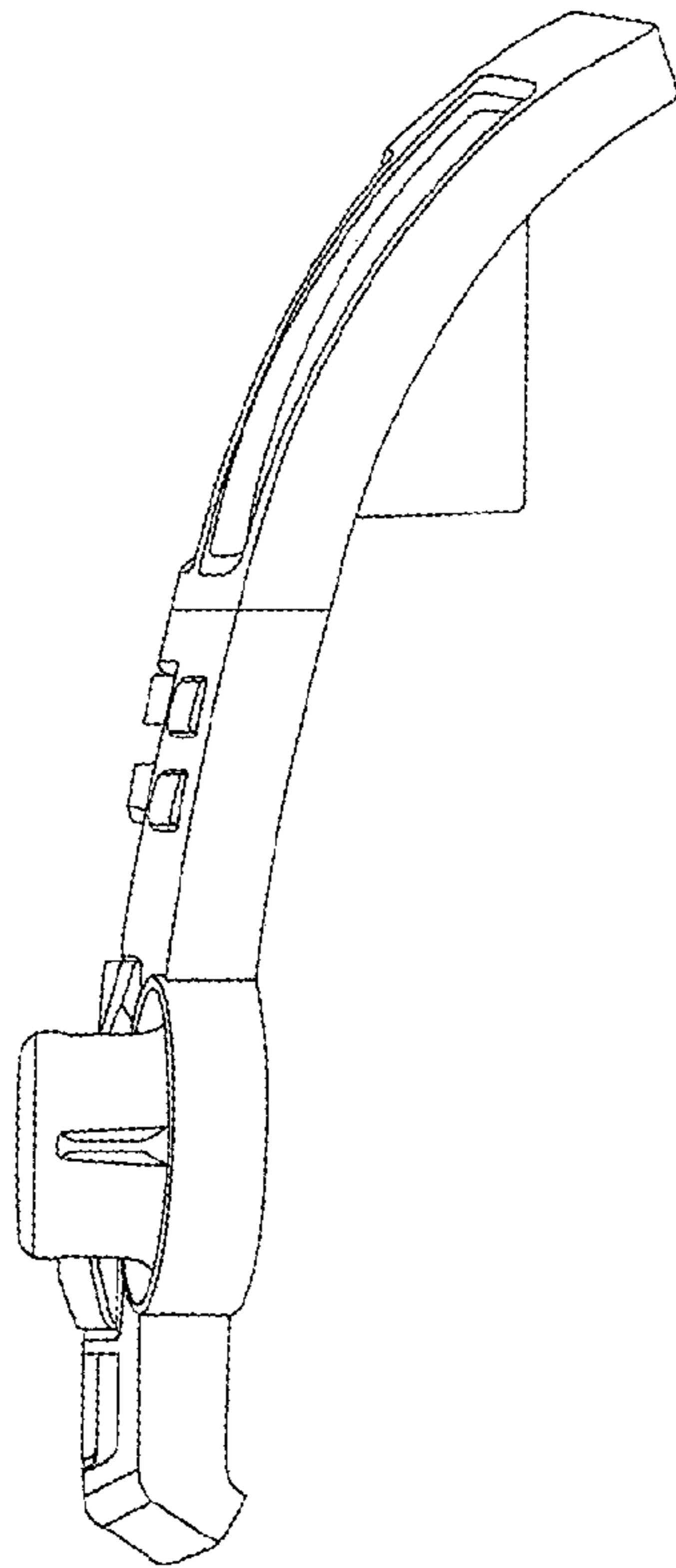

FIG. 7

