



US00D559165S

(12) **United States Design Patent**
Jackson

(10) **Patent No.:** **US D559,165 S**
(45) **Date of Patent:** **** Jan. 8, 2008**

(54) **STACKABLE WATERCRAFT FLOATATION DOCK WITH ROLLERS**

(74) *Attorney, Agent, or Firm*—Donald W. Meeker

(76) **Inventor:** **Jeffrey Jackson**, 609 Webster Point, Chapin, SC (US) 29036

(57) **CLAIM**

The ornamental design for a stackable watercraft floatation dock with rollers, as shown and described.

(**) **Term:** **14 Years**

(21) **Appl. No.:** **29/285,778**

DESCRIPTION

(22) **Filed:** **Apr. 10, 2007**

(51) **LOC (8) Cl.** **12-06**

(52) **U.S. Cl.** **D12/316**

(58) **Field of Classification Search** D12/300,
D12/302, 307, 316, 317; 114/15, 16, 44,
114/45, 259, 263; 405/4, 5; 415/537
See application file for complete search history.

FIG. 1 is a top perspective view of the stackable watercraft floatation dock with rollers of the present invention;

FIG. 2 is a bottom perspective view of the stackable watercraft floatation dock with rollers of FIG. 1;

FIG. 3 is a bottom plan view of the stackable watercraft floatation dock with rollers of FIG. 1;

FIG. 4 is a back end elevational view of the stackable watercraft floatation dock with rollers of FIG. 1;

FIG. 5 is a top plan view of the stackable watercraft floatation dock with rollers of FIG. 1;

FIG. 6 is a side elevational view of the stackable watercraft floatation dock with rollers of FIG. 1;

FIG. 7 is a front end elevational view of the stackable watercraft floatation dock with rollers of FIG. 1; and,

FIG. 8 is a top perspective view of the stackable watercraft floatation dock with rollers of FIG. 1 showing a watercraft and driver mounted thereon.

The broken lines are for illustrative purposes only and form no part of the claimed design.

(56) **References Cited**

U.S. PATENT DOCUMENTS

D398,576 S *	9/1998	Hillman et al.	D12/316
D401,547 S *	11/1998	Karliner	D12/316
6,520,728 B1 *	2/2003	Schwitters	114/44
D506,431 S *	6/2005	Elson	D12/316
D521,442 S *	5/2006	Ostreg et al.	D12/316
7,063,033 B1 *	6/2006	Jackson	114/259
7,069,872 B2 *	7/2006	Ostreg et al.	114/263
D532,360 S *	11/2006	Ostreg et al.	D12/316
2003/0123966 A1 *	7/2003	Schwitters	414/537

* cited by examiner

Primary Examiner—Holly H. Baynham
Assistant Examiner—Cynthia M. Chin

1 Claim, 8 Drawing Sheets

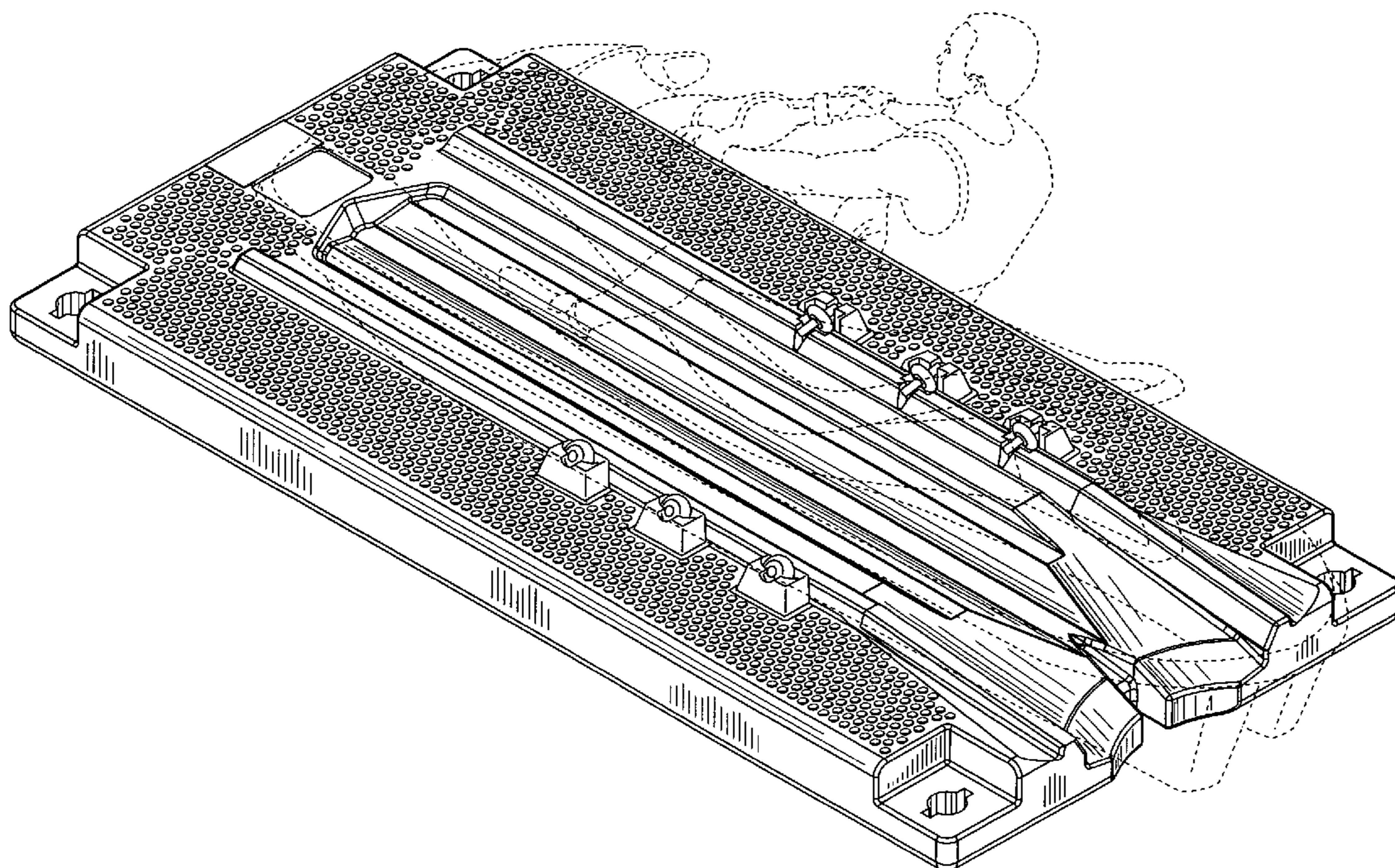

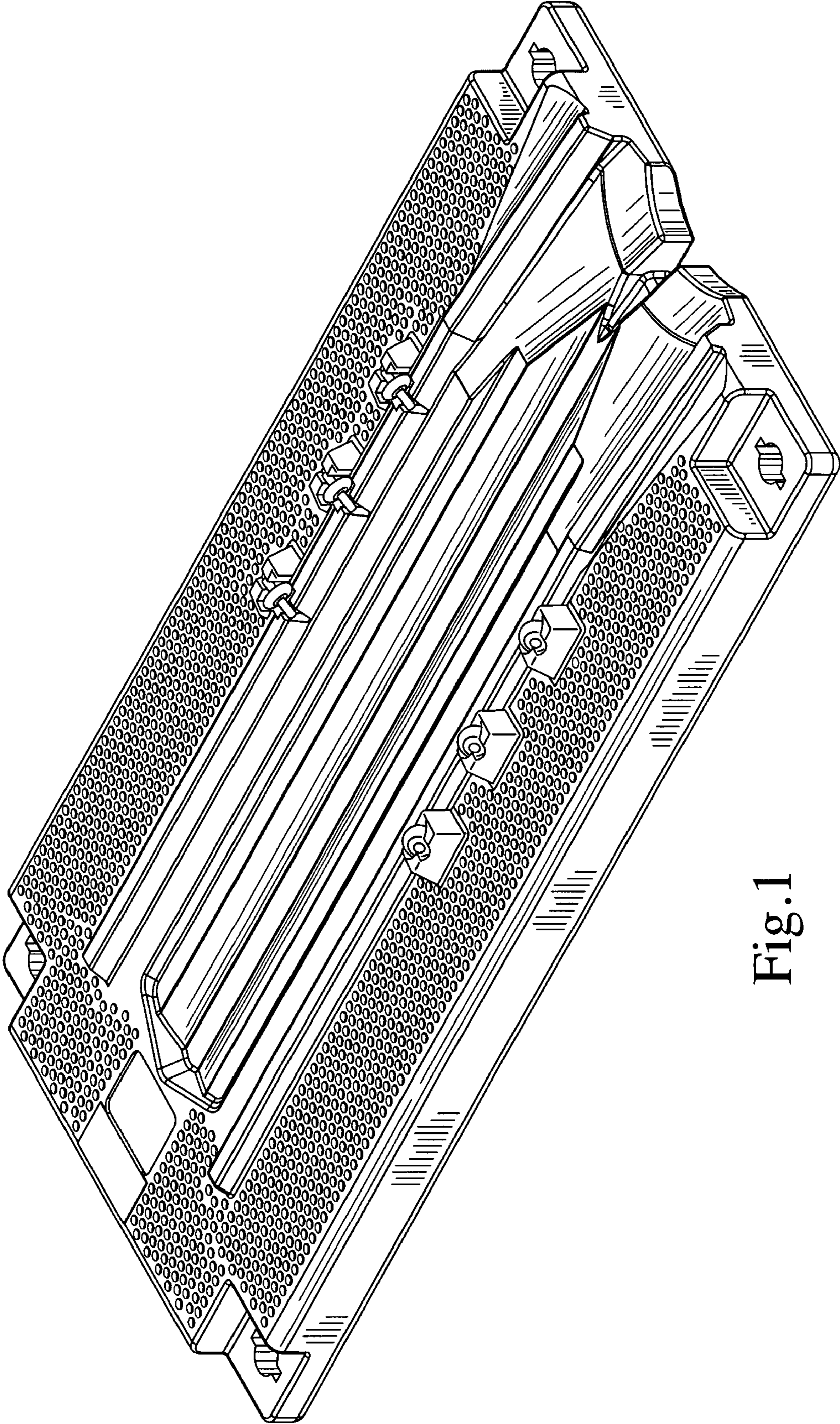

Fig.1

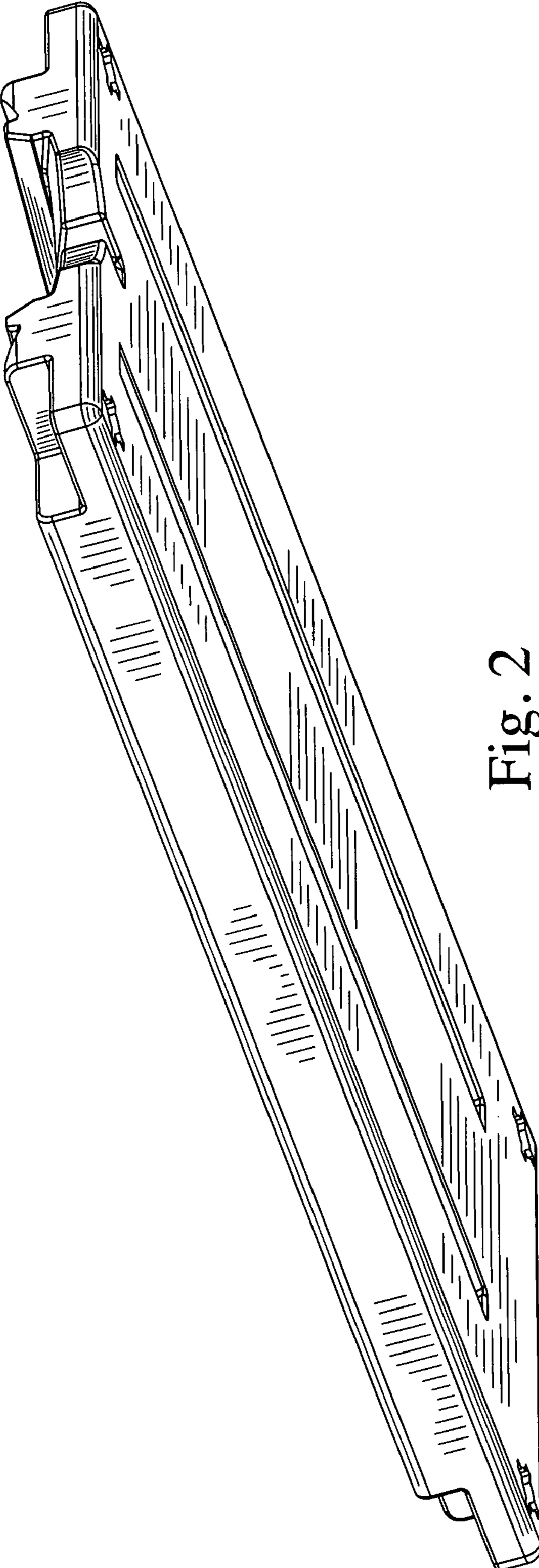

Fig. 2

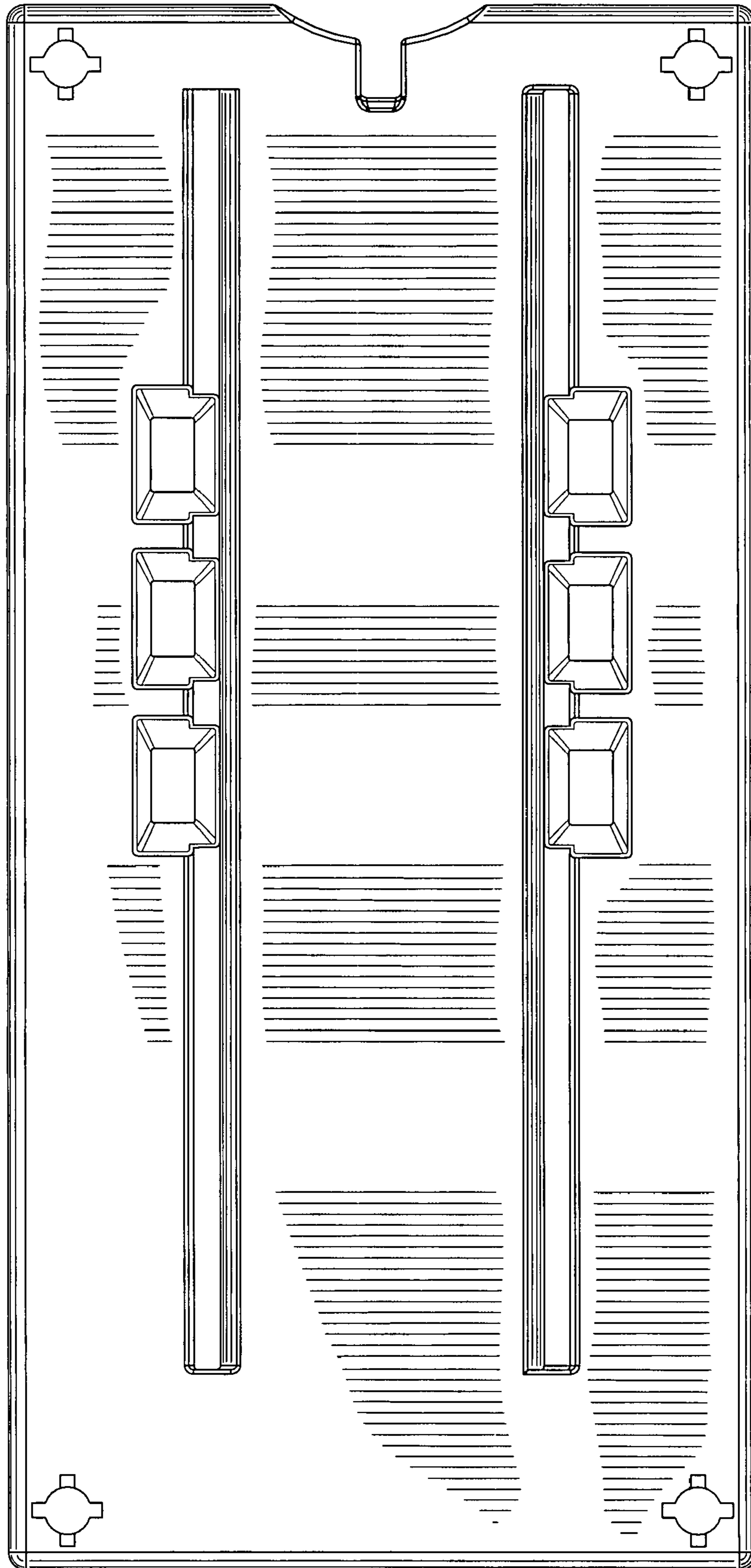

Fig. 3

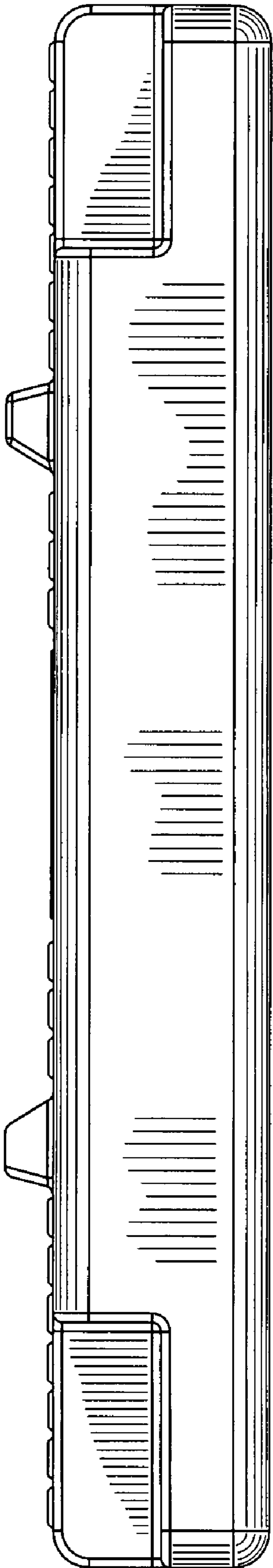

Fig. 4

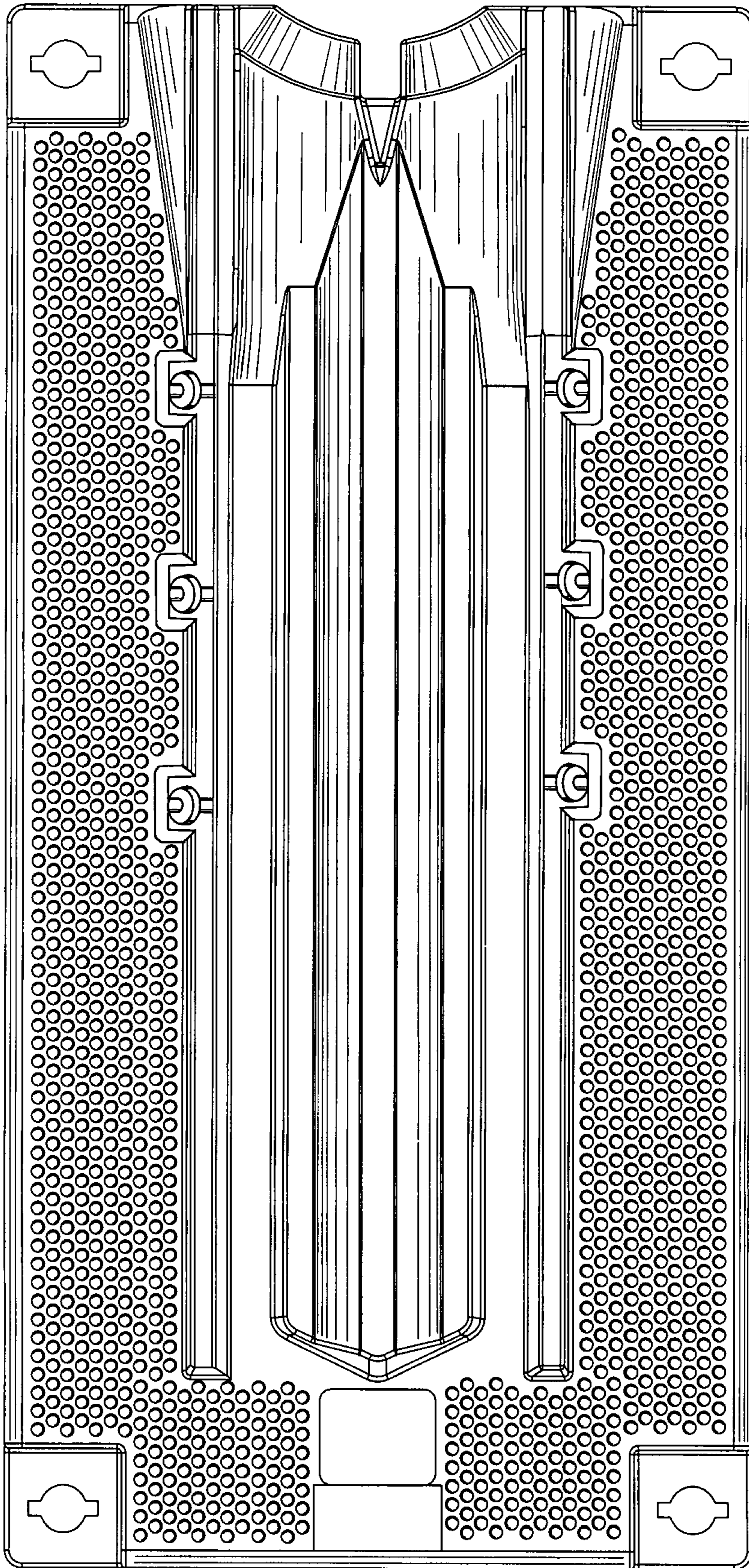

Fig. 5

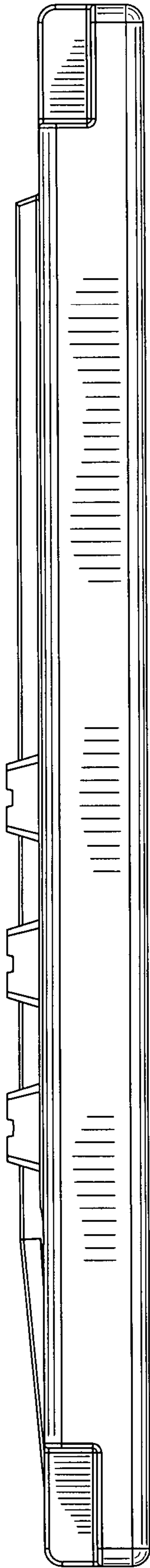

Fig.6

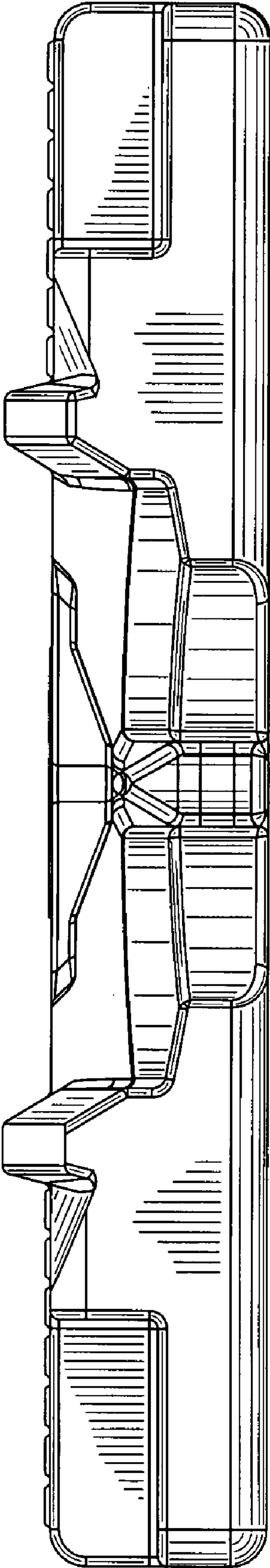

Fig.7

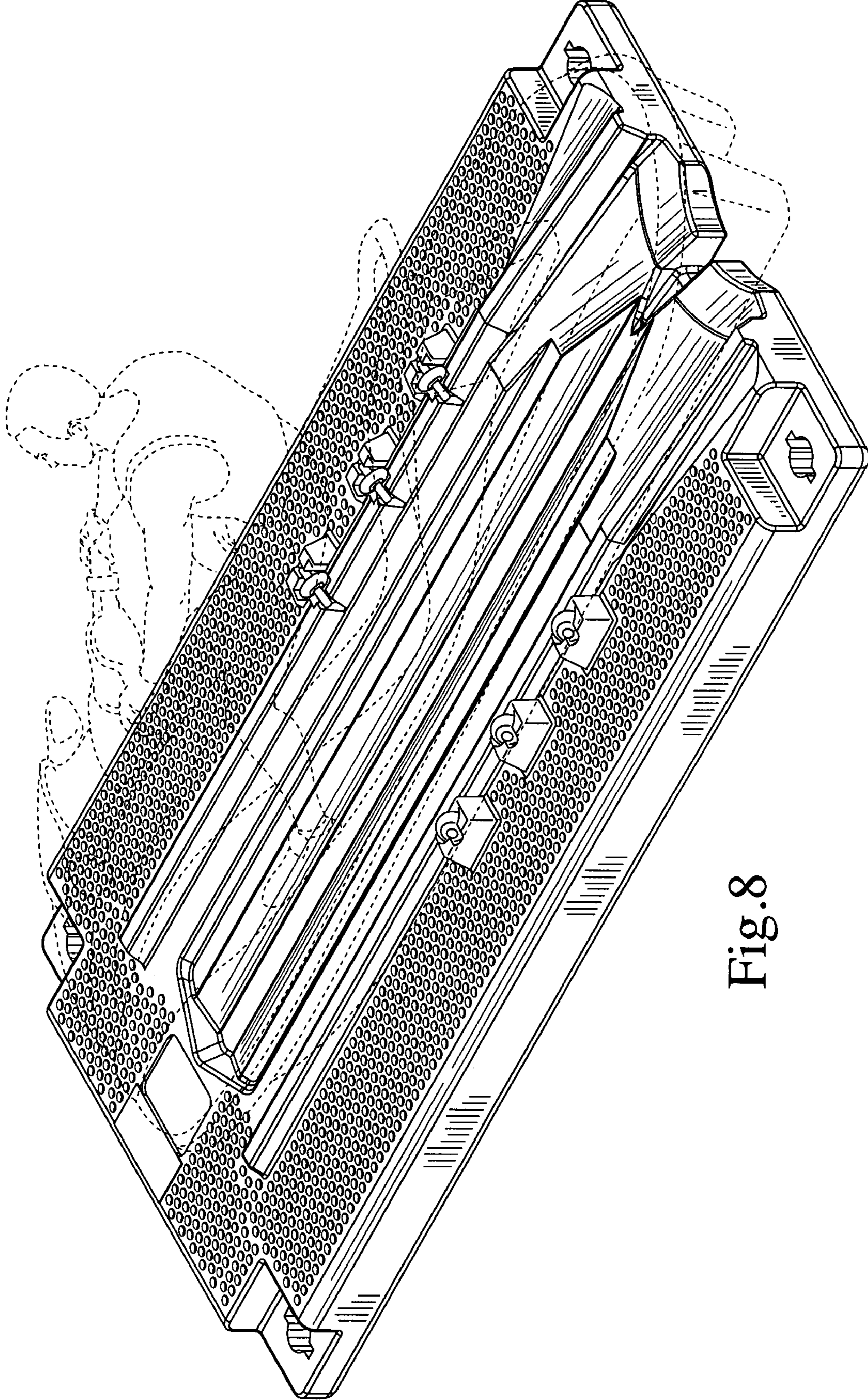

Fig. 8