



US00D558992S

(12) **United States Design Patent**
Bock

(10) **Patent No.:** **US D558,992 S**
(45) **Date of Patent:** **** Jan. 8, 2008**

(54) **SEAT FOR A COMMERCIAL AIRCRAFT PASSENGER CABIN**

U.S. Appl. No. 29/250,828. Title: Partition for a Commercial Aircraft Passenger Cabin, filed on Dec. 1, 2006.

(Continued)

(75) Inventor: **Thomas-Mathias Bock**, Grenade sur Garonne (FR)

Primary Examiner—Caron D. Veynar
Assistant Examiner—Abraham Bahta

(73) Assignee: **Airbus SAS**, Blagnac, Cedex (FR)

(74) *Attorney, Agent, or Firm*—Osler, Hoskin & Harcourt LLP

(**) Term: **14 Years**

(21) Appl. No.: **29/250,811**

(57) **CLAIM**

(22) Filed: **Dec. 1, 2006**

The ornamental design for a seat for a commercial aircraft passenger cabin, as shown and described.

(51) **LOC (8) Cl.** **06-01**

DESCRIPTION

(52) **U.S. Cl.** **D6/356**

(58) **Field of Classification Search** D6/334–336,
D6/364–365, 374–375, 356, 367, 379, 500–502;
D12/195, 345; 297/452.21, 452.29, 452.35,
297/452.38, 284.4; 244/118.5, 118.6
See application file for complete search history.

FIG. 1 is a front-left side perspective view of a seat for a commercial aircraft passenger cabin according to my design; FIG. 2 is a top plan view thereof; FIG. 3 is a right side elevation view thereof; FIG. 4 is a left side elevation view thereof; FIG. 5 is a front elevation view thereof; FIG. 6 is a rear elevation view thereof; FIG. 7 is a front-left side perspective view of the seat of FIG. 1 shown with commercial aircraft passenger cabin ottoman and partitions; FIG. 8 is a top plan view of the seat, ottoman and partitions shown in FIG. 7; FIG. 9 is a front-left side perspective view of the seat of FIG. 1 shown in a commercial aircraft passenger cabin; and, FIG. 10 is a top plan view of the seat and cabin shown in FIG. 9.

(56) **References Cited**

U.S. PATENT DOCUMENTS

D153,875 S *	5/1949	Hager	D6/356
D281,472 S *	11/1985	Soederberg	D6/356
D357,363 S *	4/1995	Frankhouse et al.	D6/356
D409,010 S *	5/1999	Papaioannou et al.	D6/356
D439,425 S *	3/2001	Park et al.	D6/356
D443,990 S *	6/2001	Berth	D6/356
D487,981 S *	4/2004	Ludeke et al.	D6/356
D488,629 S *	4/2004	Giasson	D6/356
D510,816 S *	10/2005	Lee	D6/356
D541,541 S *	5/2007	Begin et al.	D6/356

OTHER PUBLICATIONS

U.S. Appl. No. 29/250,809. Title: Partition for a Commercial Aircraft Passenger Cabin, filed on Dec. 1, 2006.
U.S. Appl. No. 29/250,814. Title: Partition for a Commercial Aircraft Passenger Cabin, filed on Dec. 1, 2006.
U.S. Appl. No. 29/250,818. Title: Partition for a Commercial Aircraft Passenger Cabin, filed on Dec. 1, 2006.

No bottom plan view is included as no features of the claimed design are visible therein.

Throughout the Figures, the broken lines showing environment or structure are for illustrative purposes only and form no part of the claimed design.

1 Claim, 9 Drawing Sheets

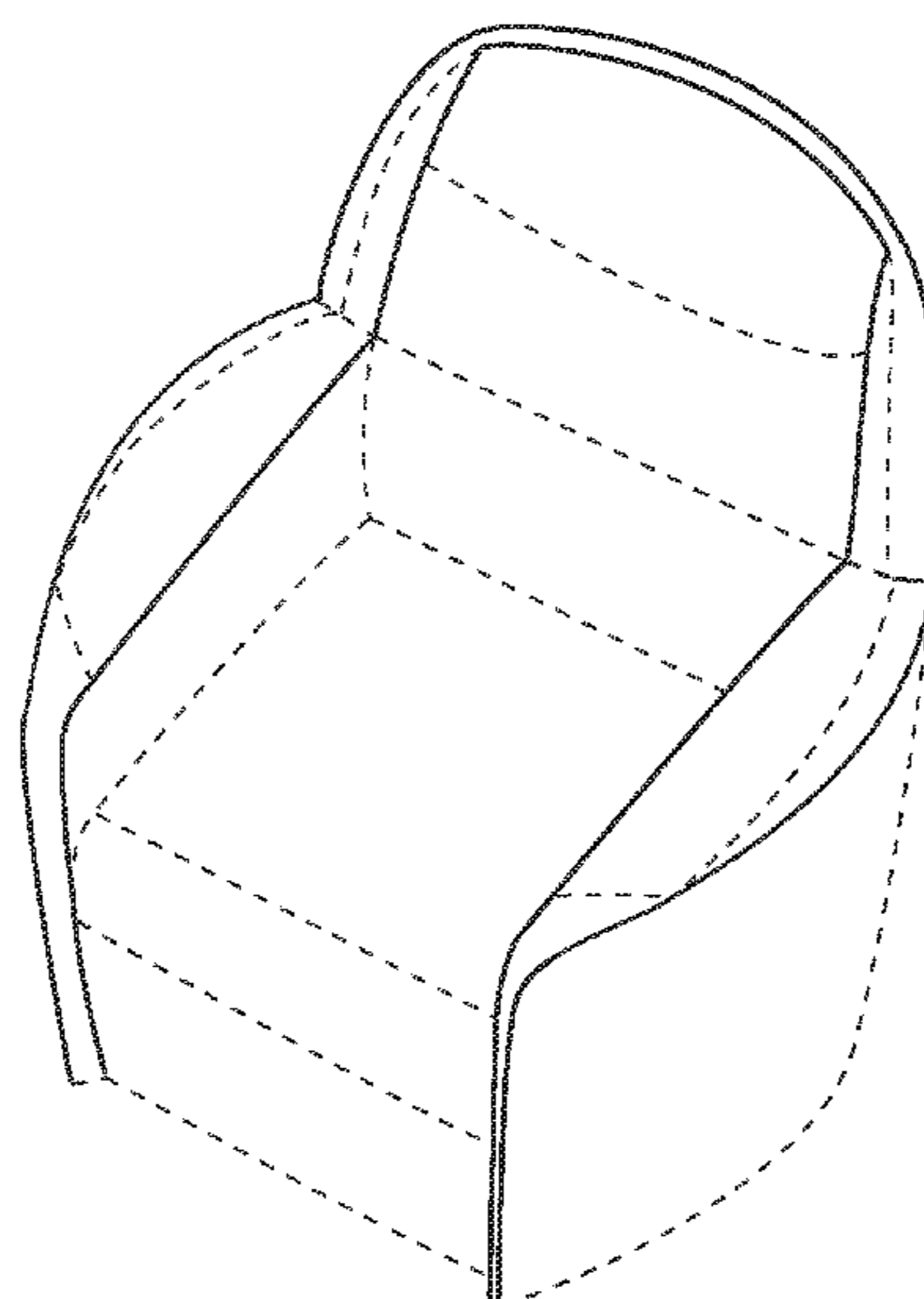

OTHER PUBLICATIONS

U.S. Appl. No. 29/250,831. Title:Seat Body for a Commercial Aircraft Passenger Cabin, filed on Dec. 1, 2006.

U.S. Appl. No. 29/250,826. Title:Seat Layout for a Commercial Aircraft Passenger Cabin, filed on Dec. 1, 2006.

U.S. Appl. No. 29/250,825. Title:Partition Layout for a Commercial Aircraft Passenger Cabin, filed on Dec. 1, 2006.

U.S. Appl. No. 29/250,833. Title:Partition Layout for a Commercial Aircraft Passenger Cabin, filed on Dec. 1, 2006.

U.S. Appl. No. 29/250,834. Title:Partition Layout for a Commercial Aircraft Passenger Cabin, filed on Dec. 1, 2006.

U.S. Appl. No. 29/250,832. Title:Ottoman for a Commercial Aircraft Passenger Cabin, filed on Dec. 1, 2006.

U.S. Appl. No. 29/250,810. Title:Furniture for a Commercial Aircraft Passenger Cabin, filed on Dec. 1, 2006.

U.S. Appl. No. 29/250,829. Title:Furniture for a Commercial Aircraft Passenger Cabin, filed on Dec. 1, 2006.

U.S. Appl. No. 29/250,813. Title:Armrest/Backrest Combination for an Ottoman for a Commercial Aircraft Passenger Cabin, filed on Dec. 1, 2006.

* cited by examiner

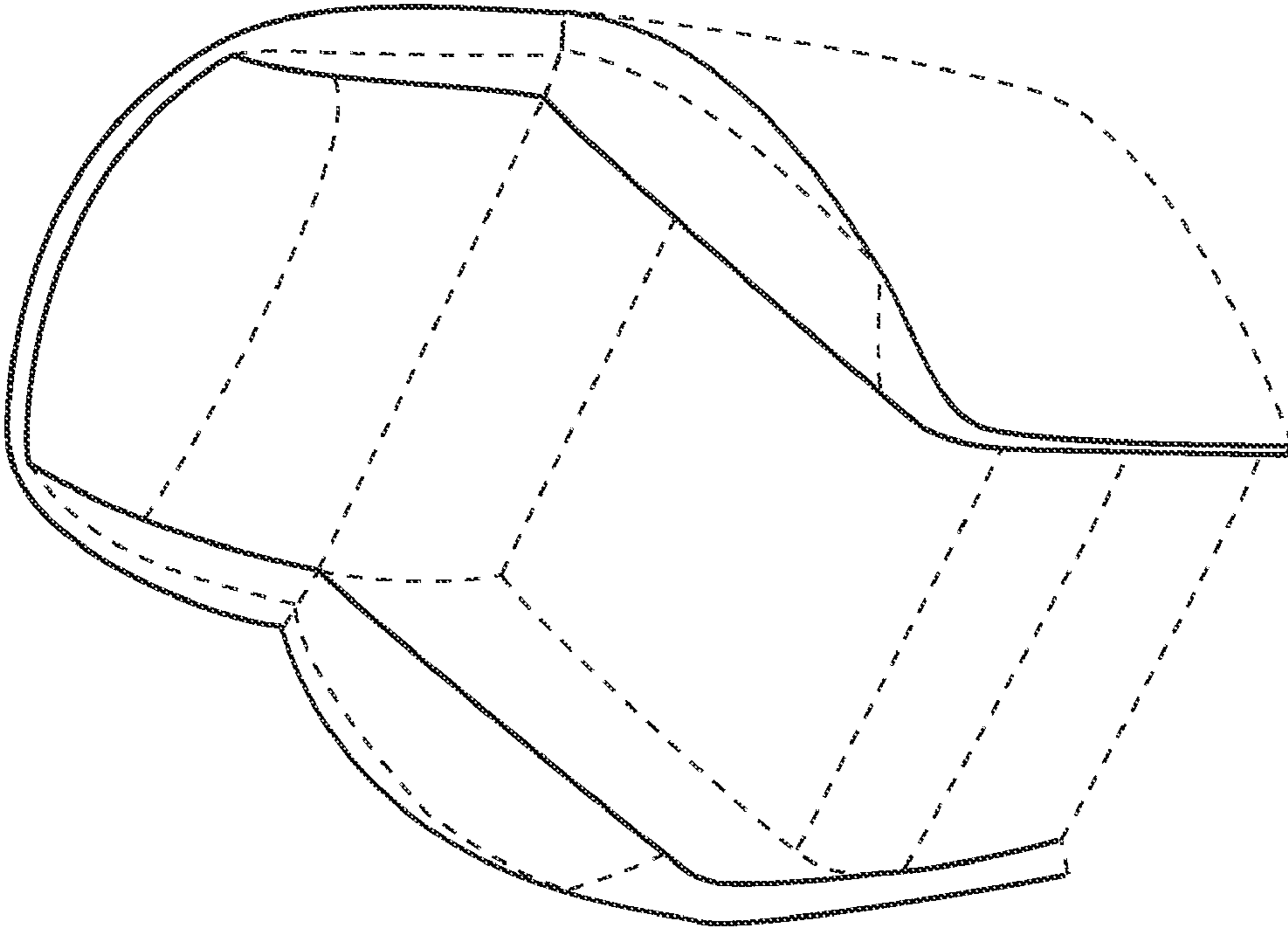

FIG. 1

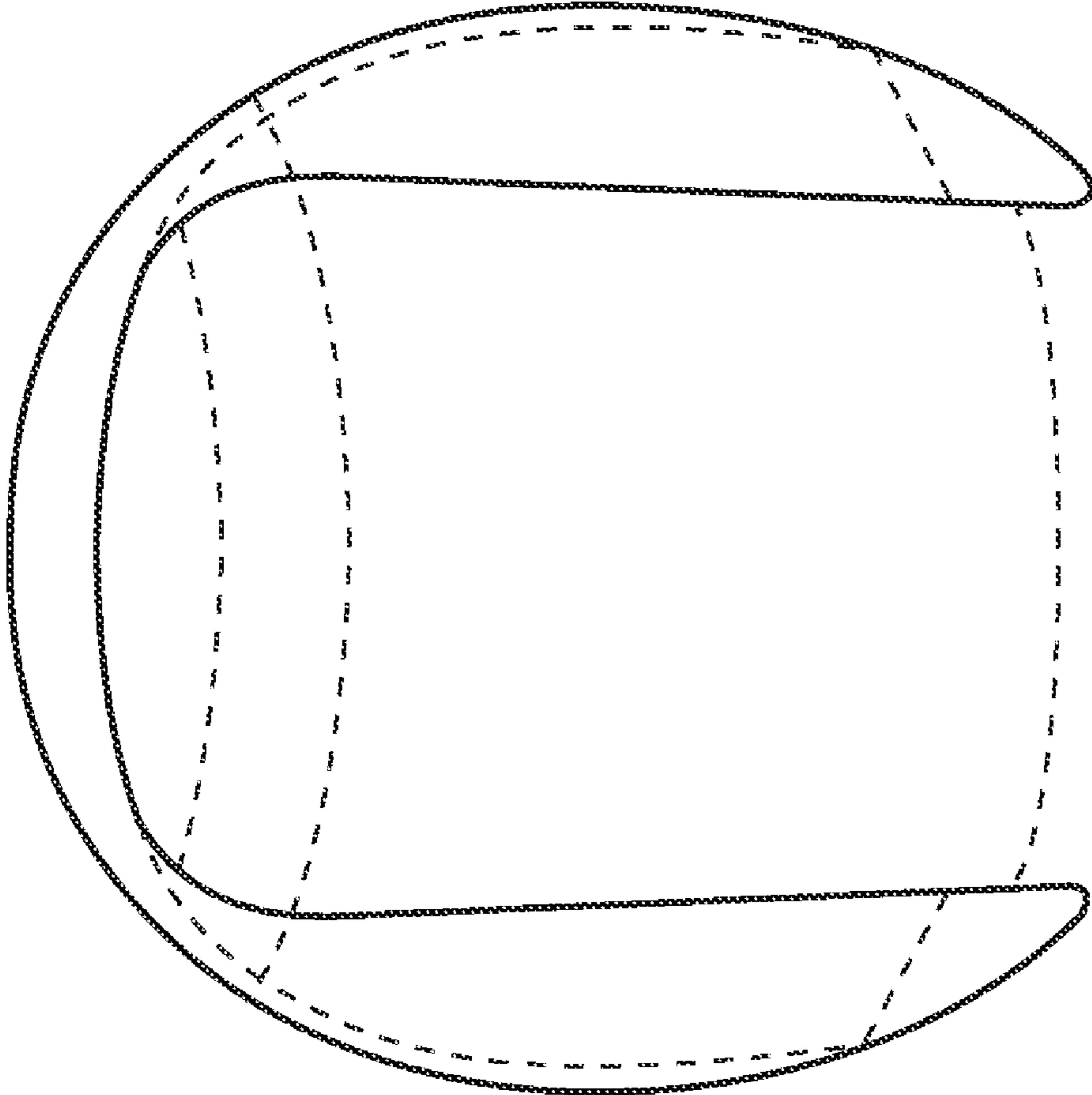

FIG. 2

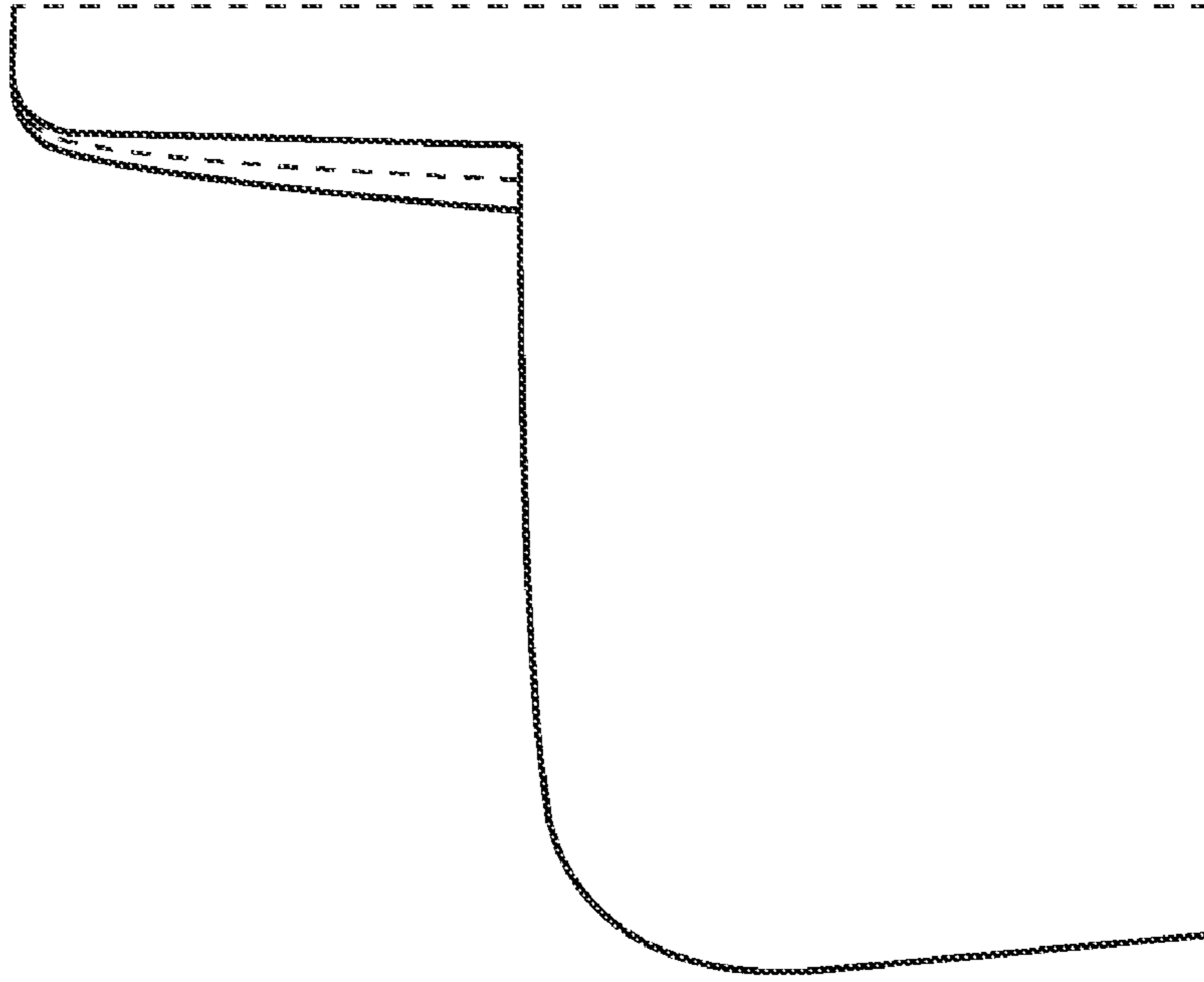

FIG. 4

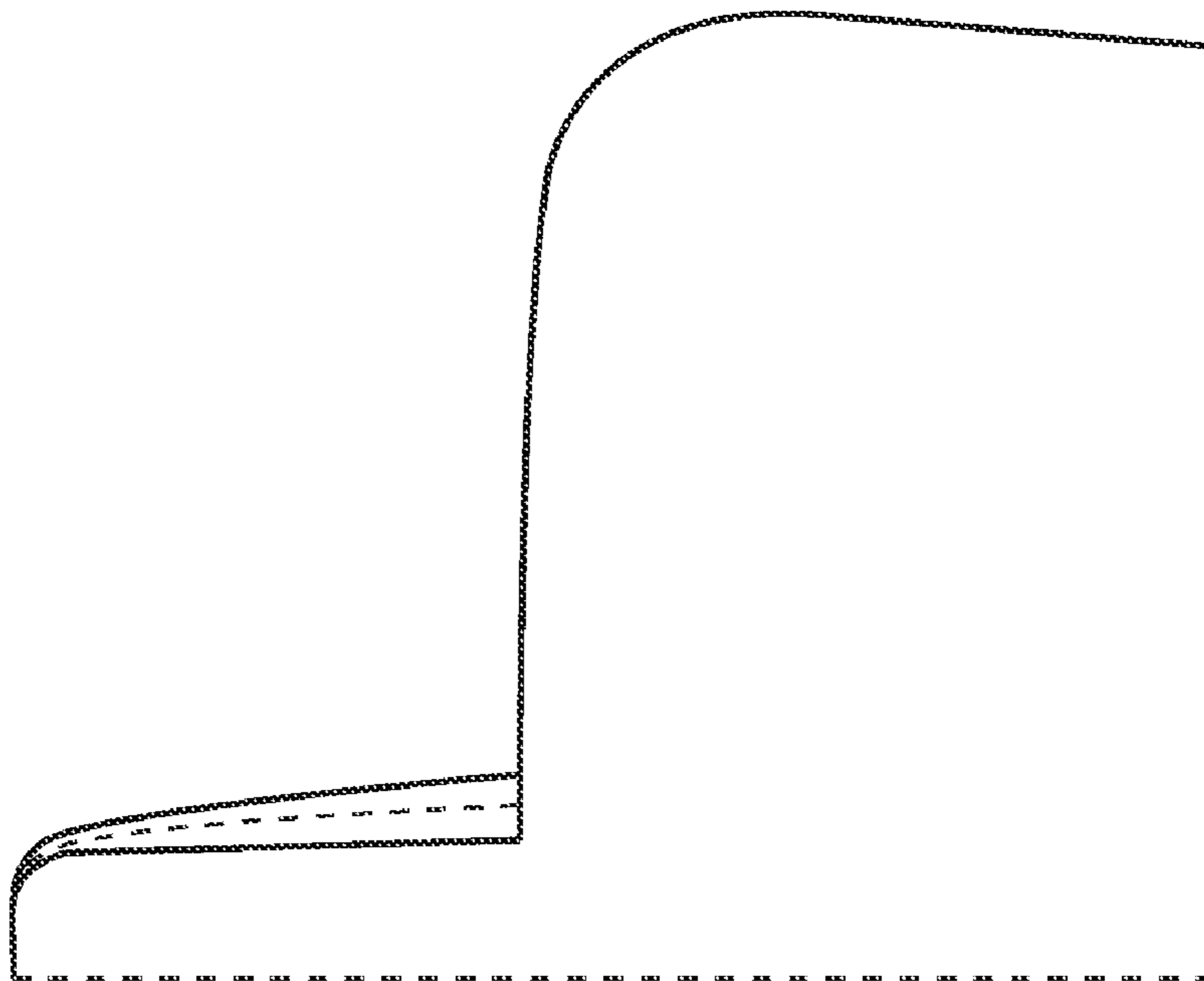

FIG. 3

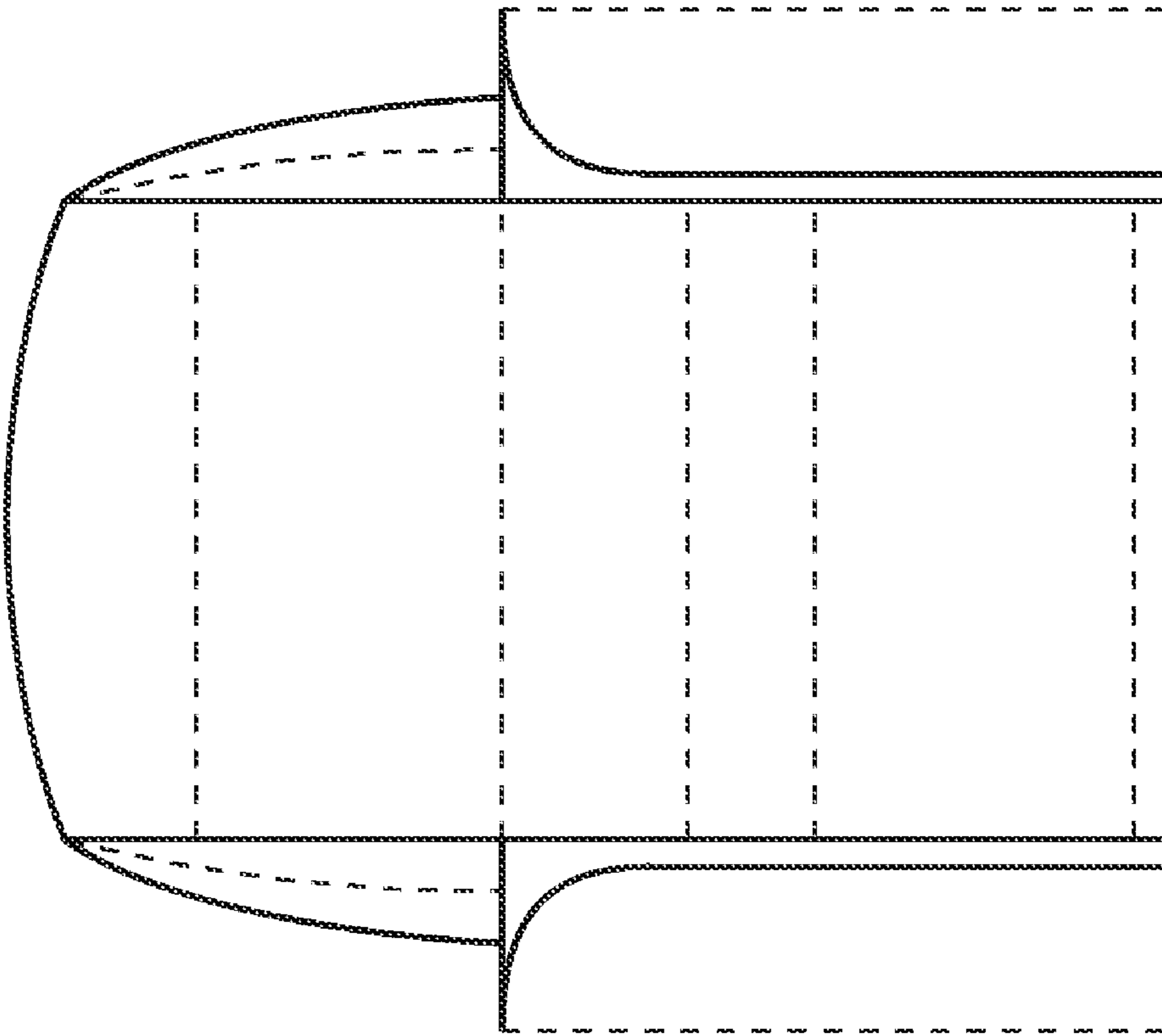

FIG. 5

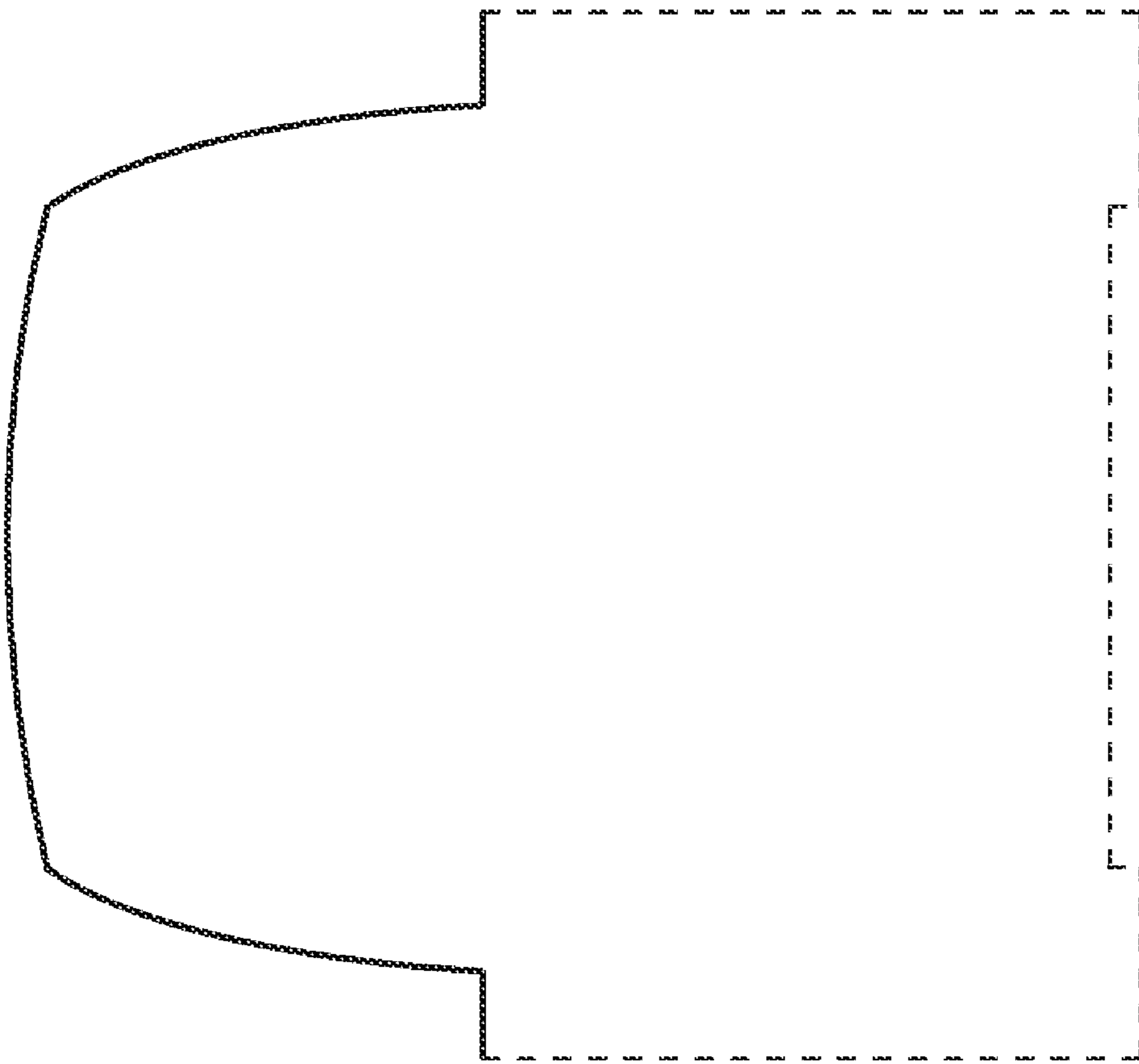

FIG. 6

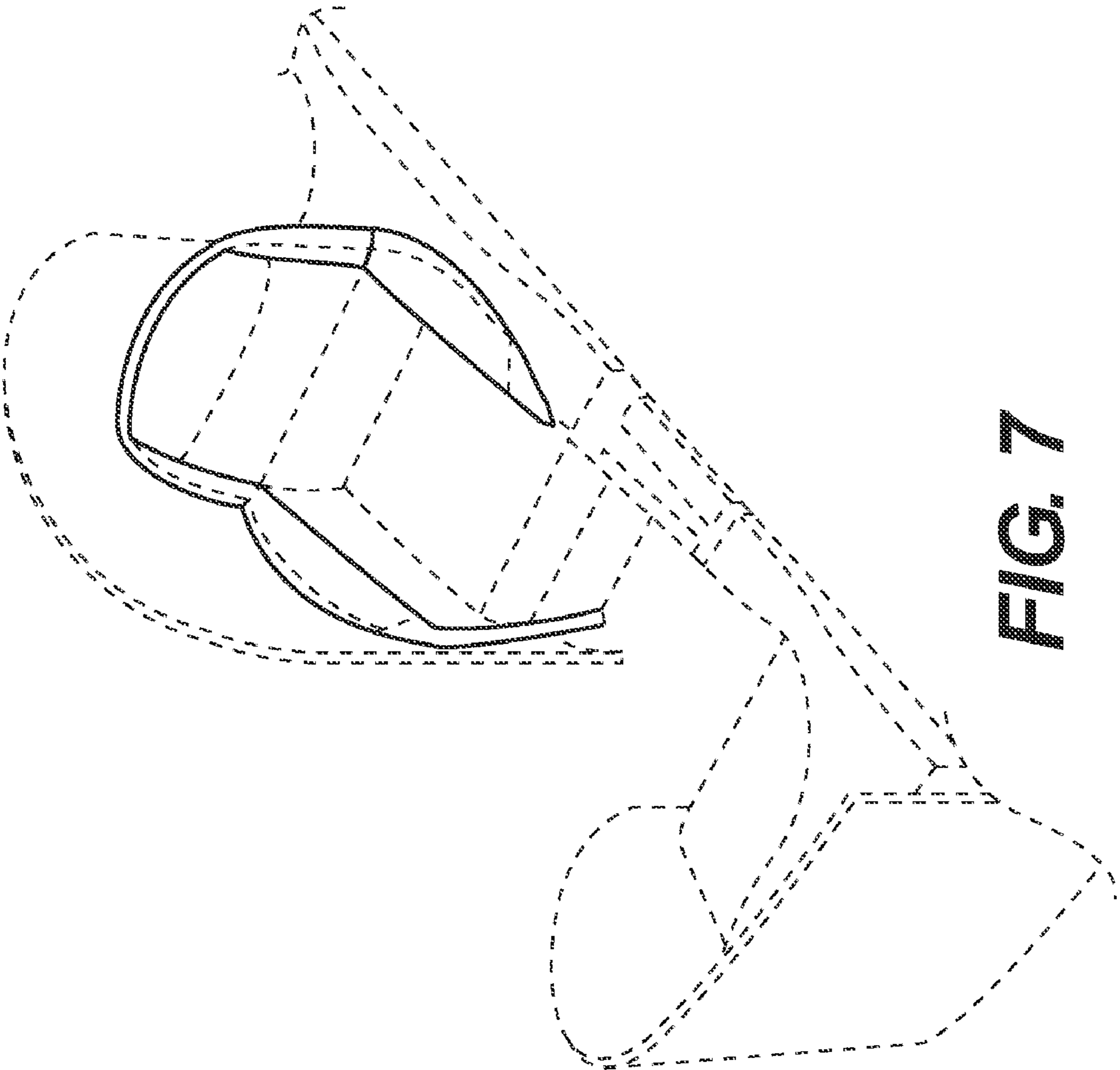

FIG. 7

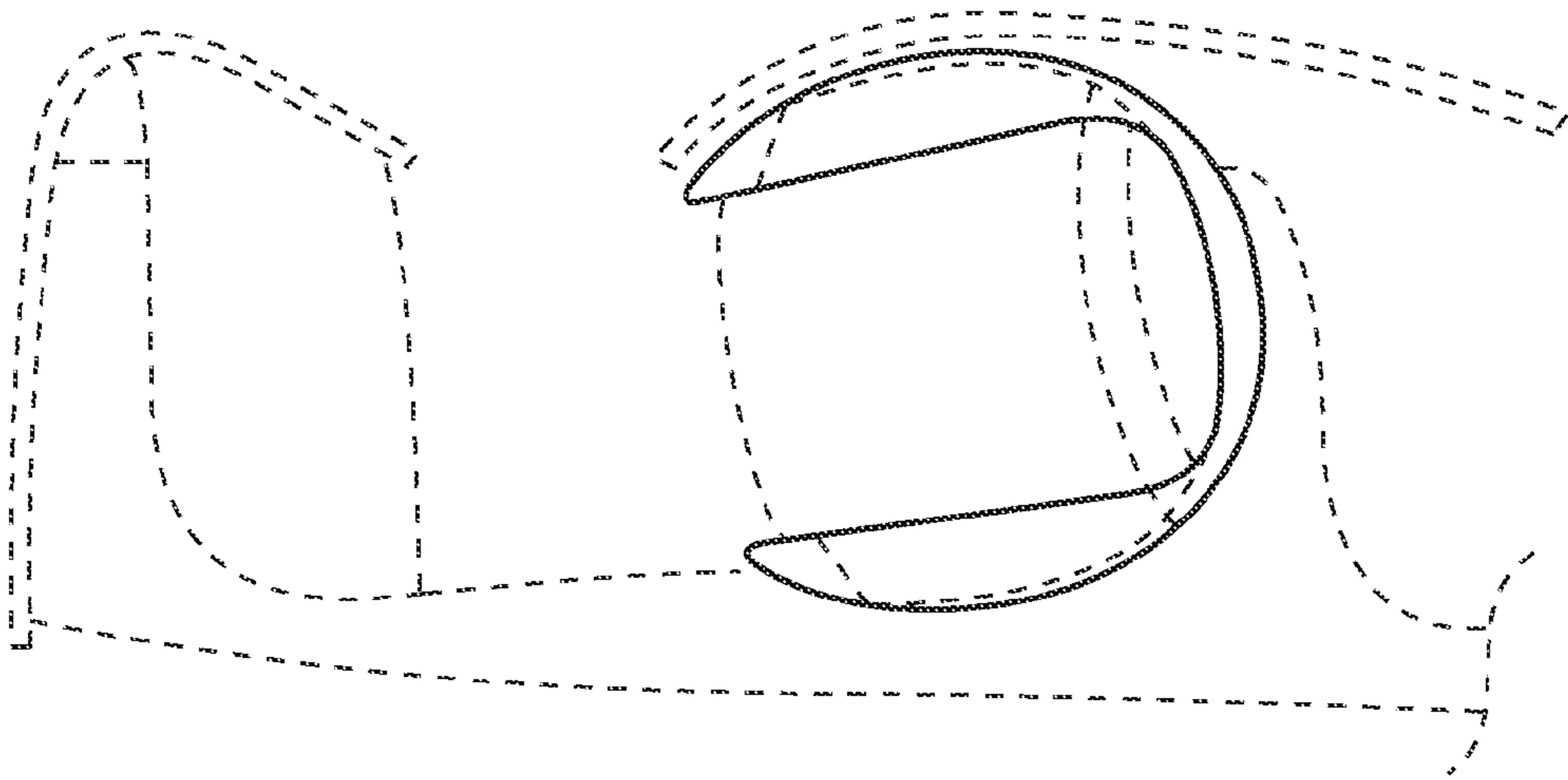

FIG. 8

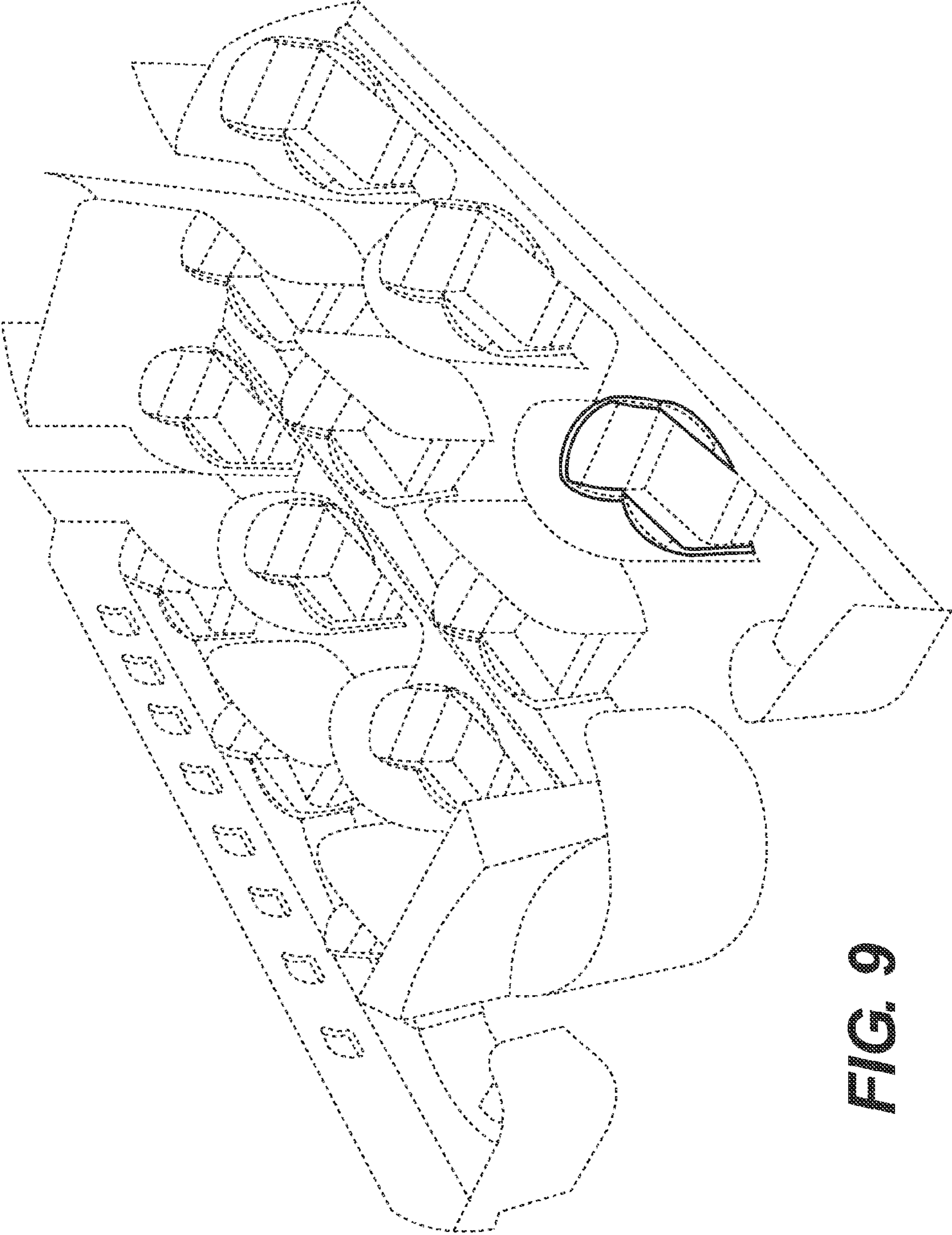

FIG. 9

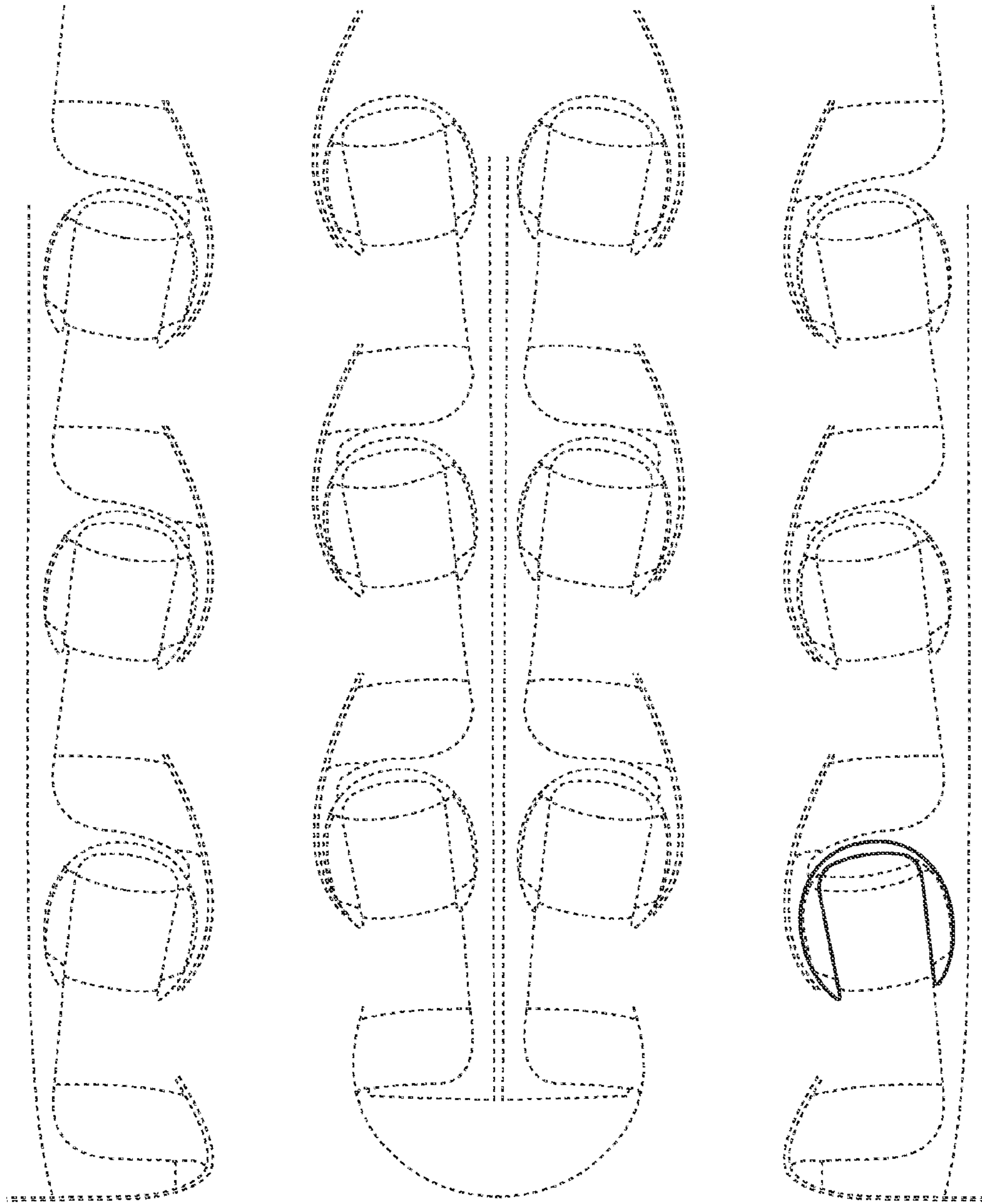

FIG. 10