



US00D558957S

(12) **United States Design Patent**
Wilkenfeld et al.

(10) **Patent No.:** **US D558,957 S**
(45) **Date of Patent:** **** Jan. 8, 2008**

(54) **DANCE FOOTWEAR**

(75) Inventors: **David Wilkenfeld**, Sydney (AU);
Felicia Leoncelli, Sydney (AU)

(73) Assignee: **Pointe Noir Pty Ltd.** (AU)

(**) Term: **14 Years**

(21) Appl. No.: **29/247,193**

(22) Filed: **Jun. 5, 2006**

(51) **LOC (8) Cl.** **02-04**

(52) **U.S. Cl.** **D2/902**

(58) **Field of Classification Search** D2/896,
D2/902, 907, 915, 936, 941; D24/192; 2/239,
2/409; 36/3 A, 7.1 R, 83; 602/30, 66
See application file for complete search history.

(56) **References Cited**

U.S. PATENT DOCUMENTS

726,778	A	4/1903	Smith	
900,881	A	10/1908	Parker	
1,754,054	A	4/1930	Selva	
1,872,641	A	8/1932	Capezio	
1,930,188	A *	10/1933	Arthur	602/66
2,237,652	A *	4/1941	Capezio	36/8.3
2,252,315	A	8/1941	Doree	
2,544,270	A	3/1951	L'Hollier	
2,596,038	A *	5/1952	Mayer	602/30
4,069,599	A	1/1978	Alegria	
4,277,897	A	7/1981	O'Connell	
4,495,715	A	1/1985	Fredrickson et al.	
4,535,554	A	8/1985	De Obaldia B.	
4,944,099	A	7/1990	Davis	
5,247,741	A	9/1993	Pastor	

(Continued)

FOREIGN PATENT DOCUMENTS

WO	WO 1999/051117	10/1999
WO	WO 2006/037154	4/2006

OTHER PUBLICATIONS

Capezio, dancesport, dancewear, bodywear, dance sneakers, capezio shoes; 1 page—Footundeez, H07. <http://www.capeziodance.com>

com/page.jsp?s=6&9=1462; printed Jun. 27, 2005, believed to have been published prior to the earliest effective filing date for U.S. Appl. No. 29/233,219.

Save your Sole with Dance Paws (R) Barefoot Dancers-(c) Dance Paws LLC 2002, All Rights Reserved, Patent Pending, 1 page of Search Results from WayBackMachine, 2 pages printed from Nov. 28, 2002.

PCT International Search Report and Written Opinion dated Nov. 7, 2005 prepared by ISA/AU for PCT Appl. No. PCT/AU2005/001504; filed Sep. 29, 2005; 10 pgs.

Wilkenfeld, David; Dance Footwear; Non-published U.S. design patent Appl. No. 29/233,219, filed Jun. 28, 2005, 7 pages.

Primary Examiner—Dominic Simone

Assistant Examiner—Rashids C. McCoy

(74) *Attorney, Agent, or Firm*—Ganzlaw, P.C.

(57) **CLAIM**

The ornamental design for dance footwear, as shown and described.

DESCRIPTION

FIG. 1 is a front, side perspective view-of dance footwear showing our new design, in use condition;

FIG. 2 is a front, side perspective view opposite to FIG. 1, in use condition;

FIG. 3 -an enlarged front, side perspective view;

FIG. 4 is a side elevational view;

FIG. 5 is a side elevational view opposite to FIG. 4;

FIG. 6 is a front, elevational view;

FIG. 7 is a rear, elevational view;

FIG. 8 is a top view; and,

FIG. 9 is a bottom view.

Broken lines showing features of the shoe, and any showing of a wearer's foot and leg, are for illustrative purposes only and form no part of the claimed design.

1 Claim, 4 Drawing Sheets

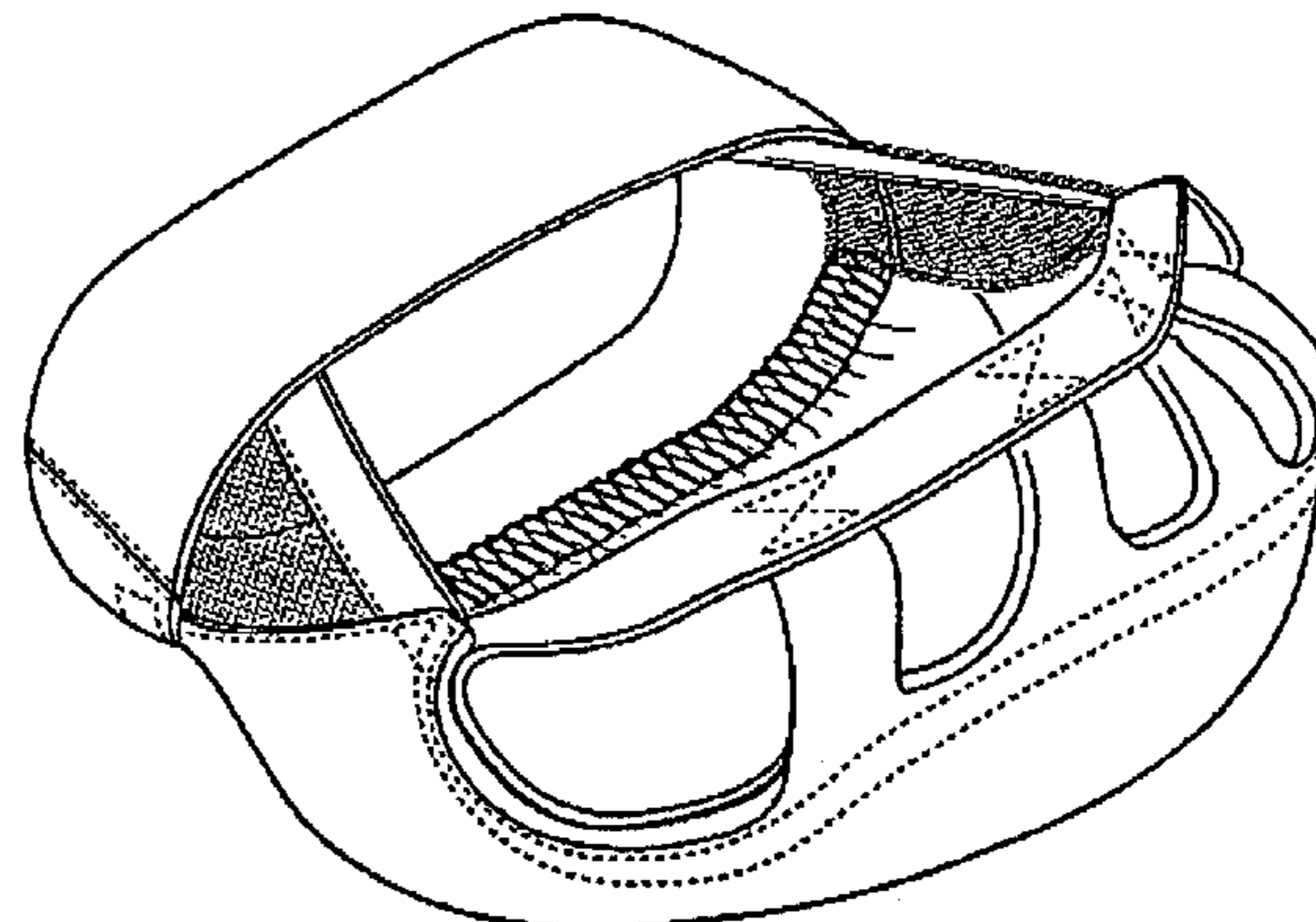
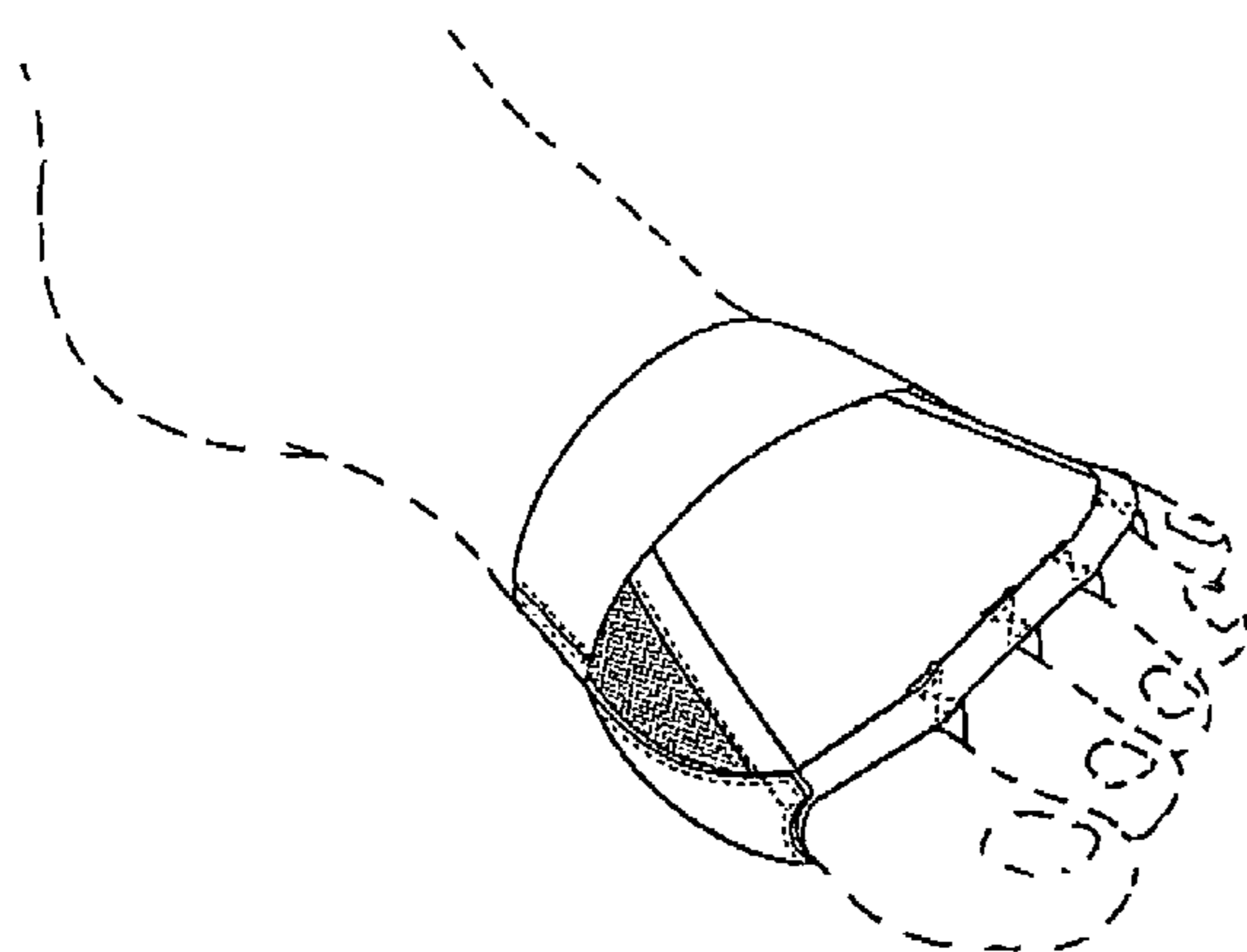

US D558,957 S

Page 3

U.S. PATENT DOCUMENTS

5,257,969	A	11/1993	Mance				
5,865,779	A *	2/1999	Gleason	602/30			
5,867,838	A *	2/1999	Corry	2/239			
5,956,868	A	9/1999	Stevens et al.				
6,018,888	A	2/2000	Wilkenfeld et al.				
D437,105	S	2/2001	Mahjied				
					D499,807	S *	12/2004
					D517,784	S	3/2006
					2002/0078591	A1	6/2002
					2006/0196078	A1	9/2006
					2006/0288609	A1	12/2006
					2007/0006486	A1	1/2007

* cited by examiner

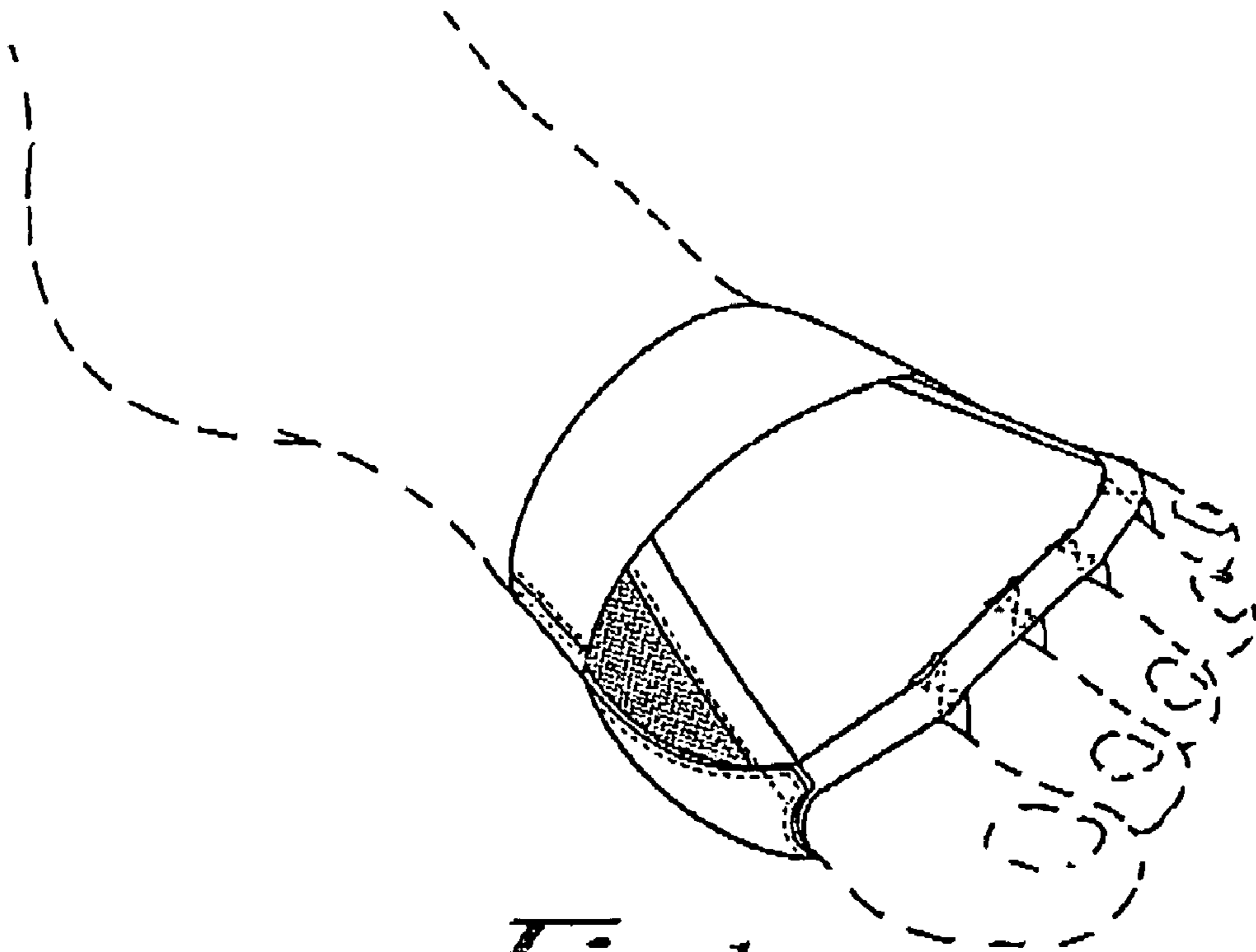

Fig. 1

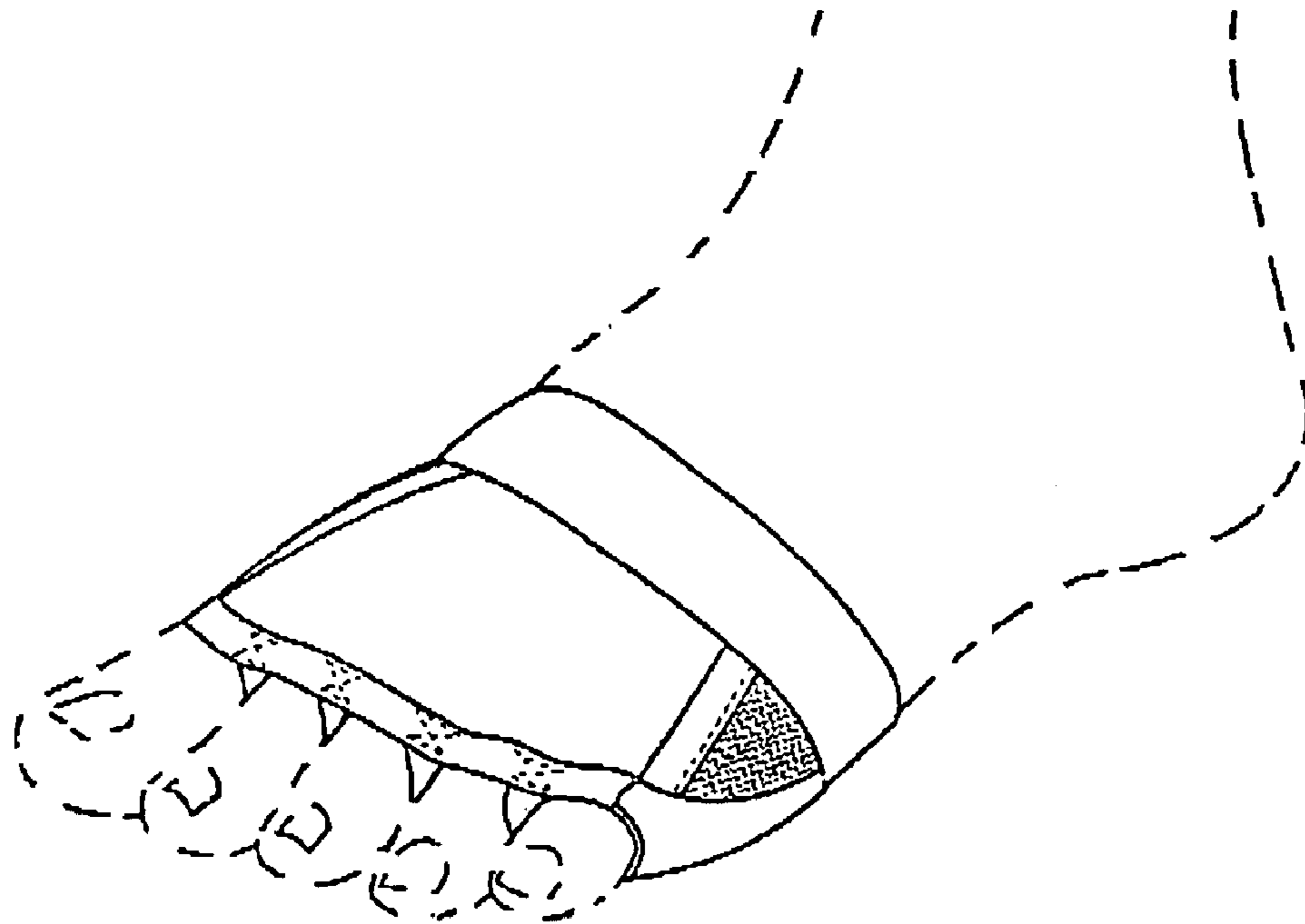

Fig. 2

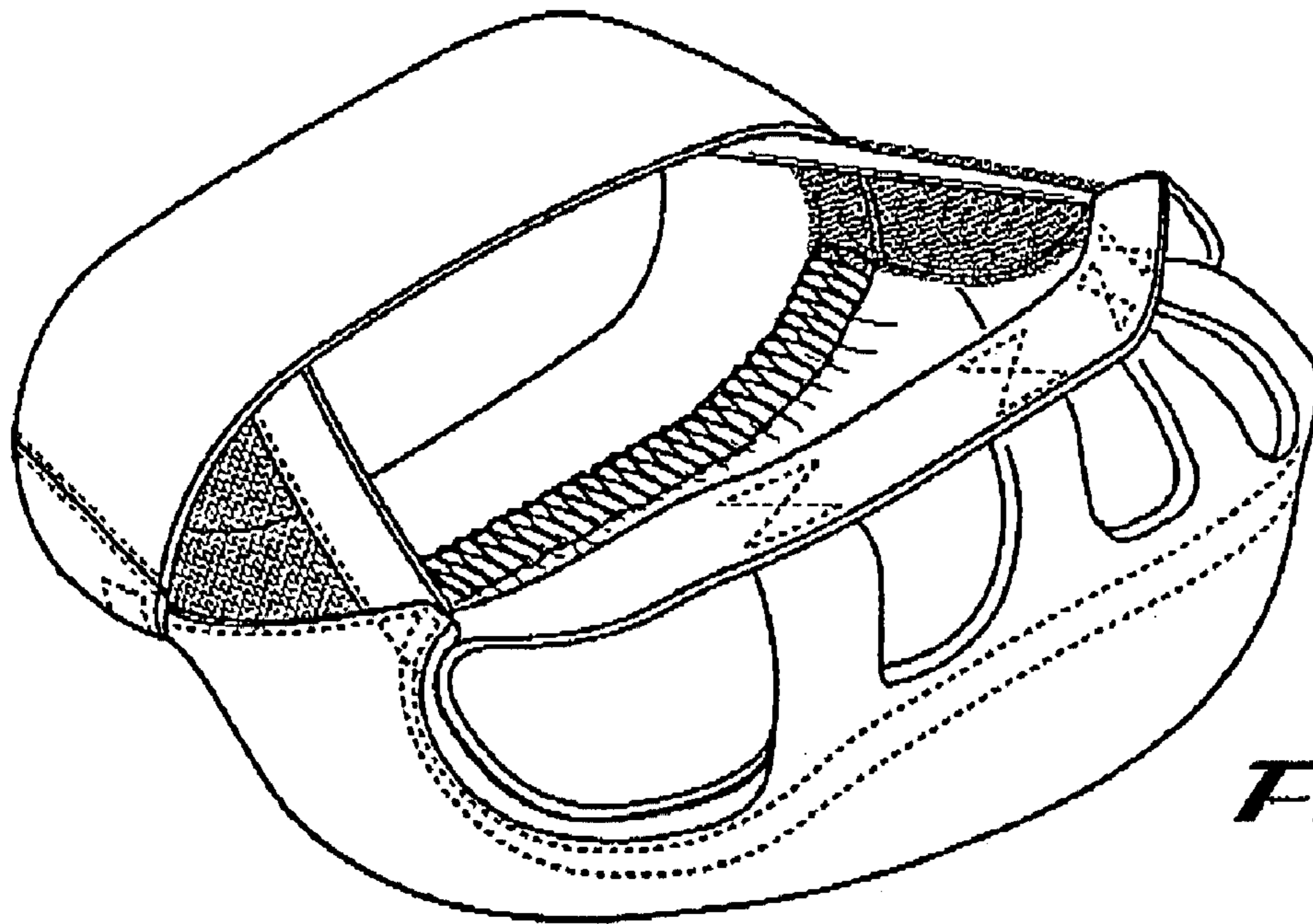

Fig. 3

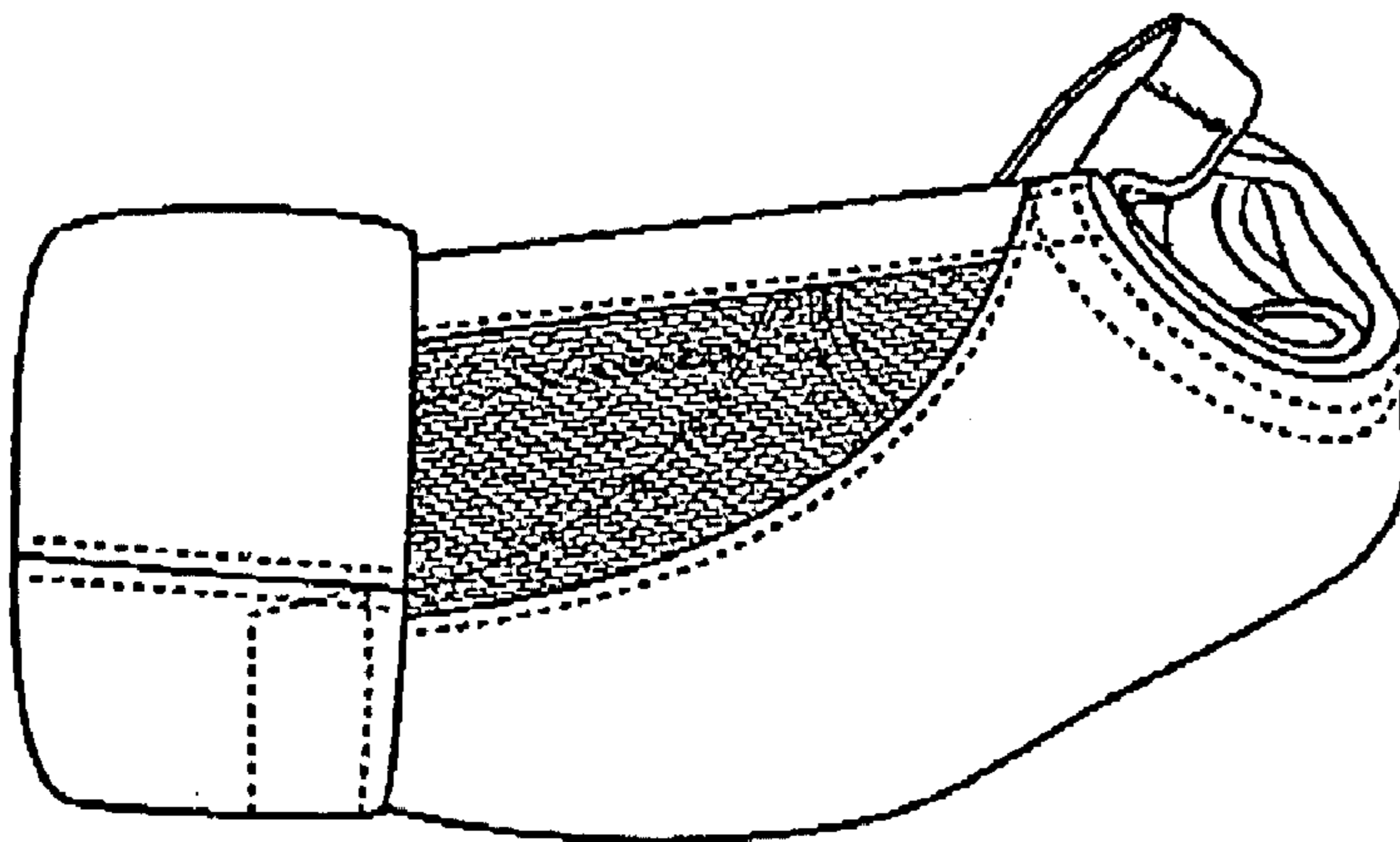
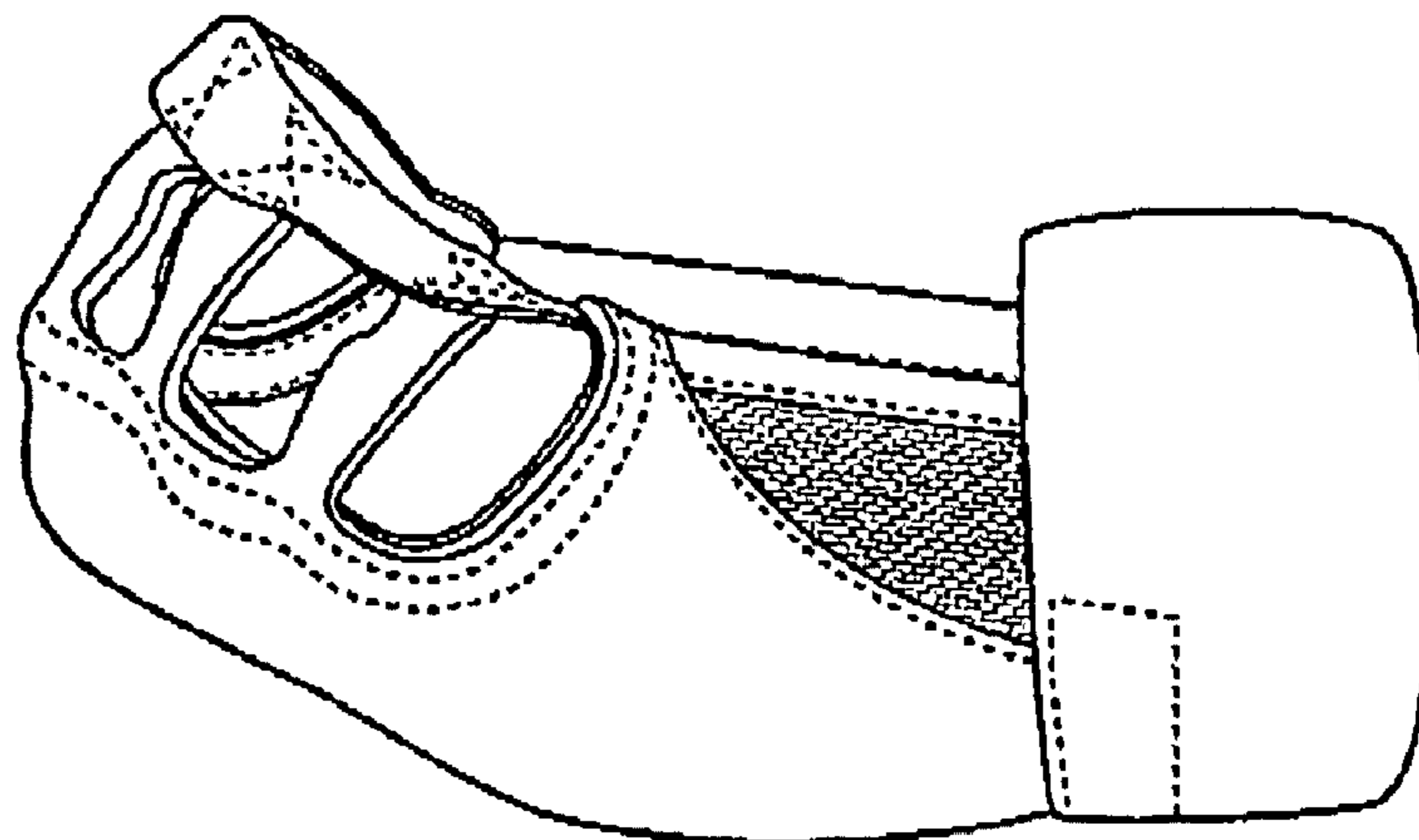

Fig. 4

Fig. 5



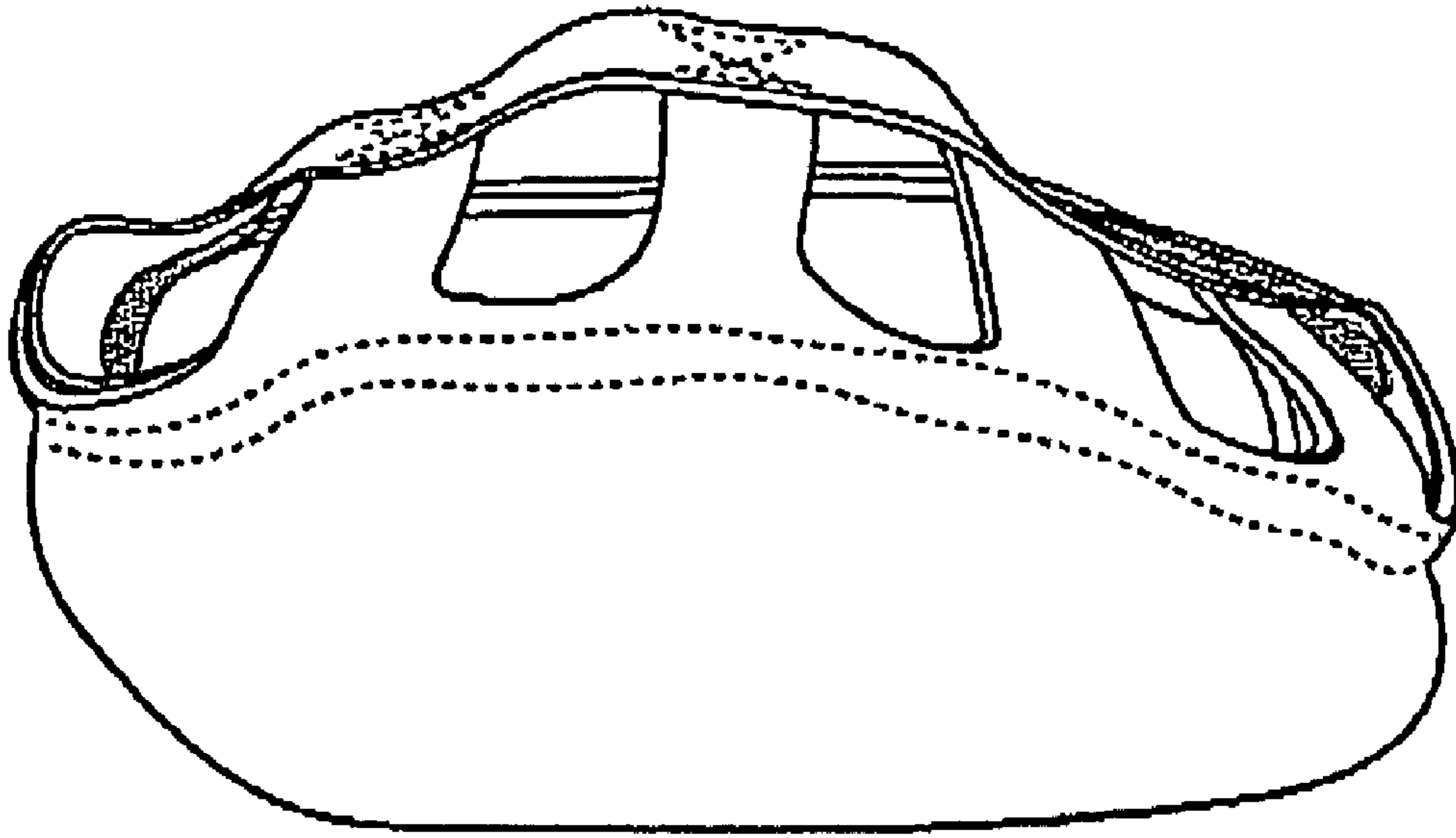

Fig. 6

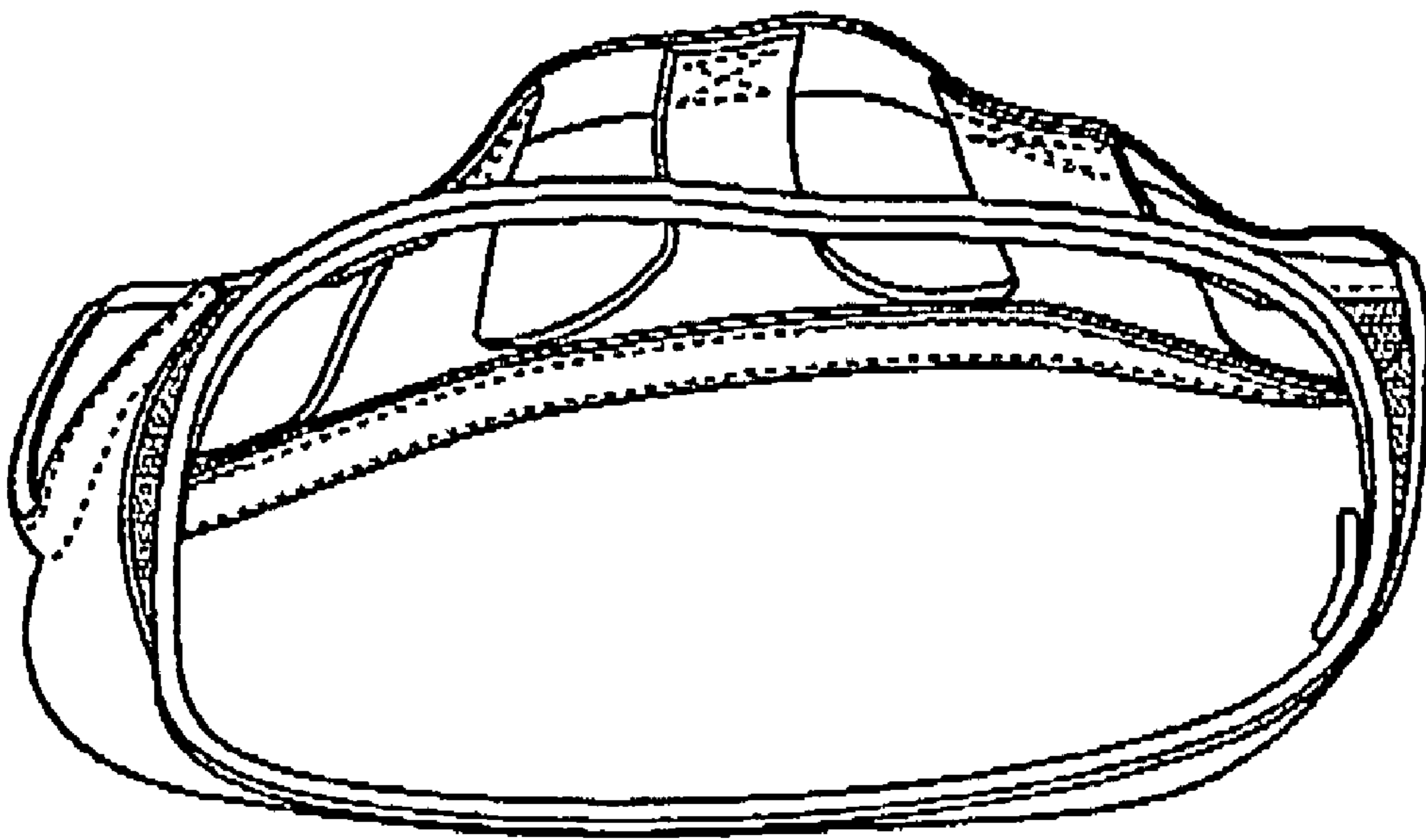

Fig. 7

Fig. 8

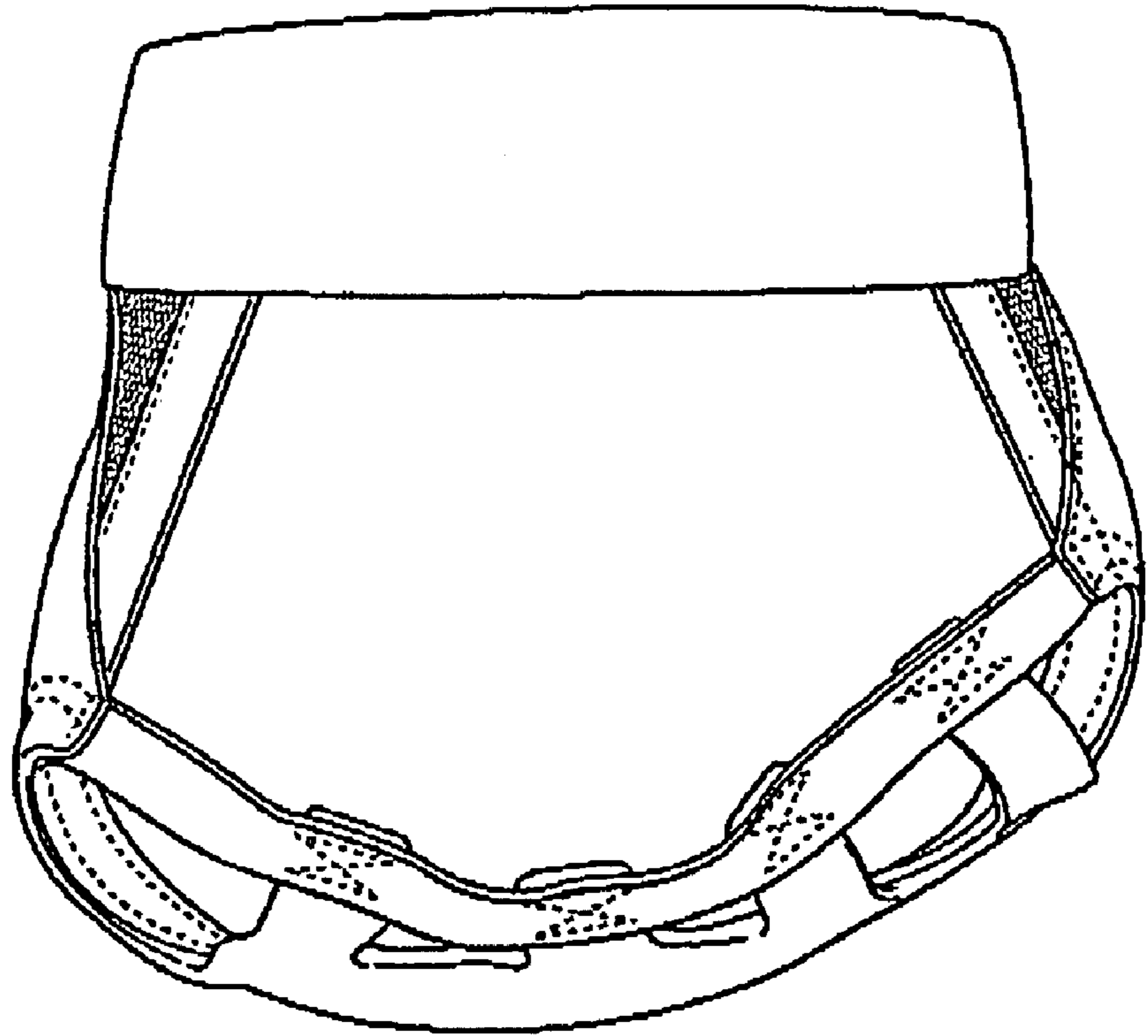

Fig. 9

