



US00D558653S

(12) **United States Design Patent** (10) **Patent No.:** **US D558,653 S**
Leclercq (45) **Date of Patent:** **** Jan. 1, 2008**

(54) **SURFACE CONFIGURATION OF A REAR FENDER FOR A VEHICLE**

Primary Examiner—Melody N. Brown
(74) *Attorney, Agent, or Firm*—Crowell & Moring LLP

(75) Inventor: **Pierre Leclercq**, Munich (DE)

(57) **CLAIM**

(73) Assignee: **Bayerische Motoren Werke Aktiengesellschaft**, Munich (DE)

The ornamental design for a surface configuration of a rear fender for a vehicle, as shown and described.

(**) Term: **14 Years**

DESCRIPTION

(21) Appl. No.: **29/270,232**

(22) Filed: **Dec. 19, 2006**

(30) **Foreign Application Priority Data**

Jun. 20, 2006 (DE) 4 06 03 285

(51) **LOC (8) Cl.** **12-16**

(52) **U.S. Cl.** **D12/184**

(58) **Field of Classification Search** D12/173,
D12/96, 97, 184; 180/69.2, 89.12, 89.13,
180/89.67, 89.7; 296/184.1

See application file for complete search history.

(56) **References Cited**

U.S. PATENT DOCUMENTS

D418,791 S *	1/2000	Gabath	D12/196
D491,857 S *	6/2004	Velazco	D12/196
D505,899 S *	6/2005	Boyer	D12/196
D522,424 S *	6/2006	Nordmann	D12/196
D542,201 S *	5/2007	Hiruta et al.	D12/196

* cited by examiner

This application is related to the following co-pending application, of the inventor, filed on even date herewith: application Ser. No. 29/270,222, entitled "Surface Configuration of a Vehicle, Toy, and/or Other Replicas".

FIG. 1 is a front perspective view a first embodiment of a surface configuration of a rear fender for a vehicle according to my novel design;

FIG. 2 is a rear perspective view thereof;

FIG. 3 is a side view thereof; and

FIG. 4 is a rear view thereof.

FIG. 5 is a front perspective view a second embodiment of the surface configuration of a rear fender for a vehicle according to my novel design;

FIG. 6 is a rear perspective view FIG. 5;

FIG. 7 is a side view FIG. 5; and,

FIG. 8 is a rear view FIG. 5.

The broken lines are for illustrative purposes only and form no part of the claimed design.

1 Claim, 4 Drawing Sheets

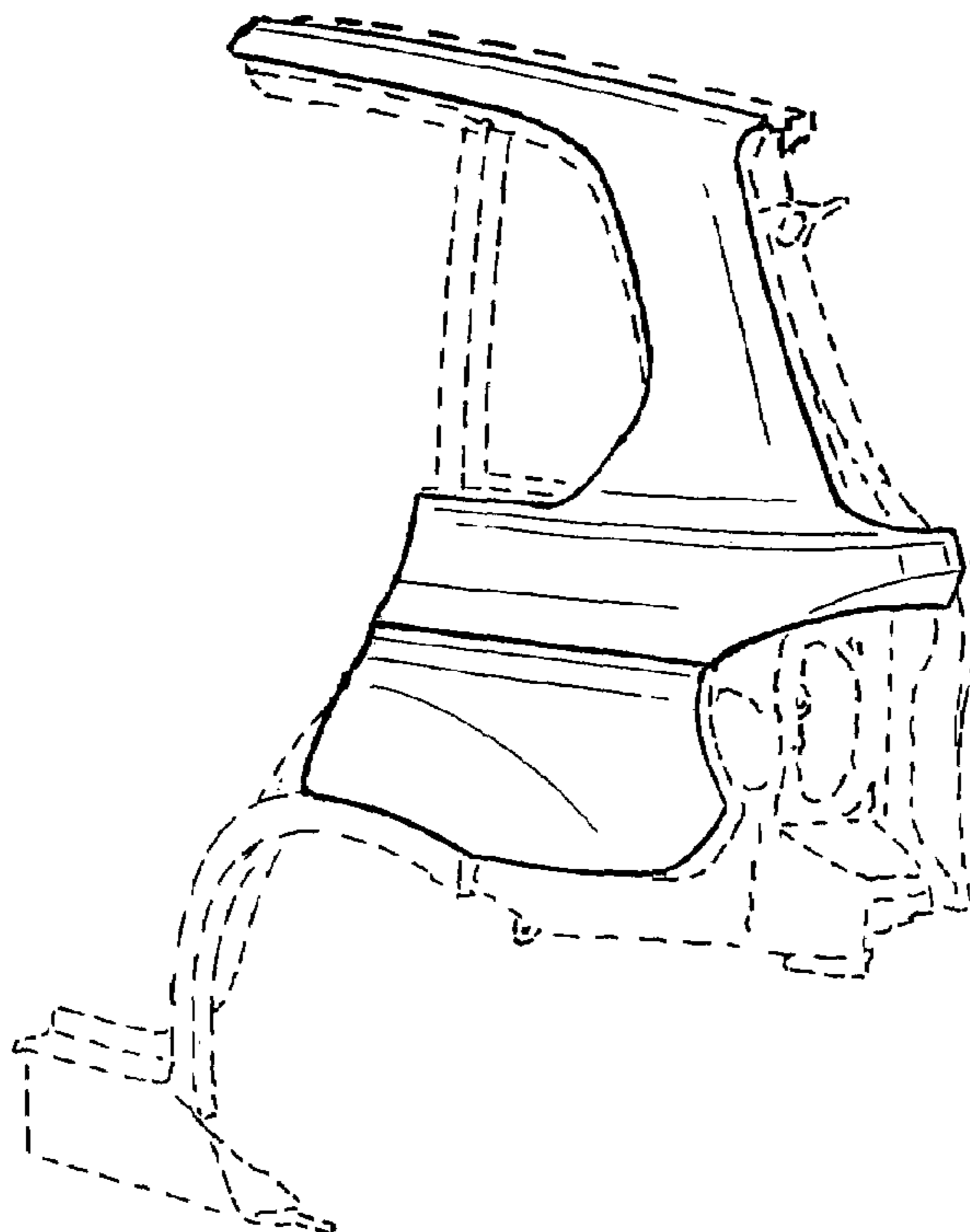

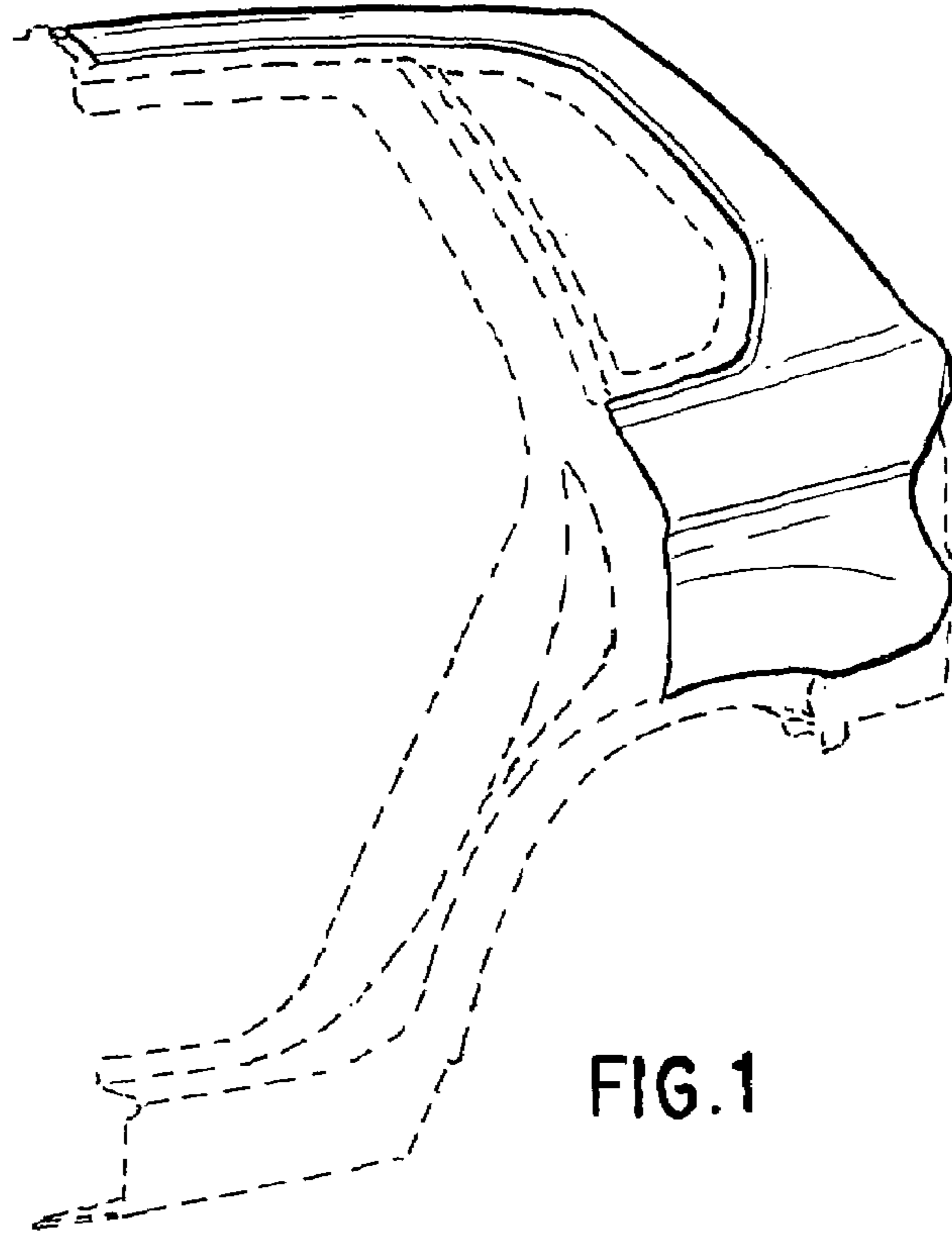

FIG. 1

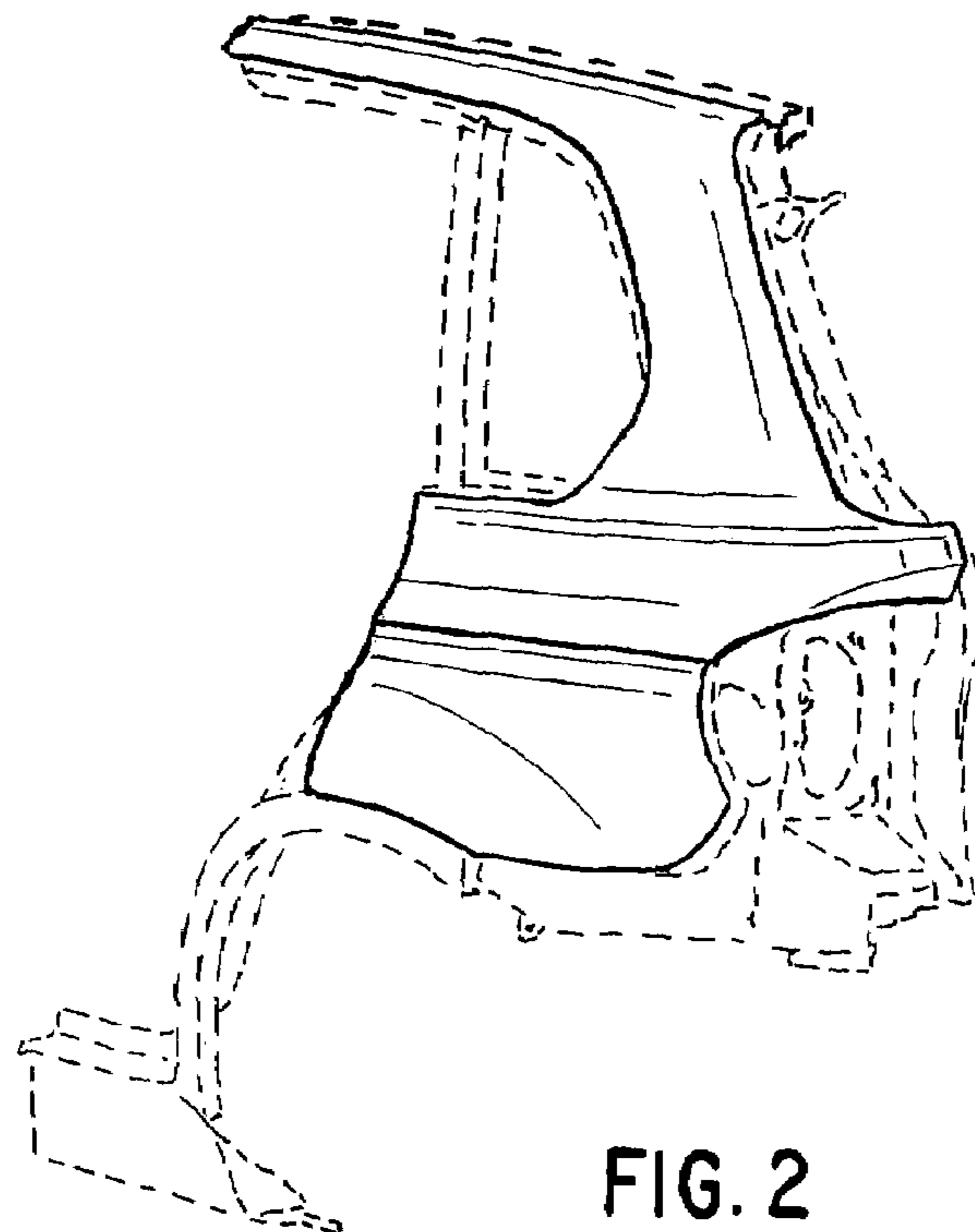

FIG. 2

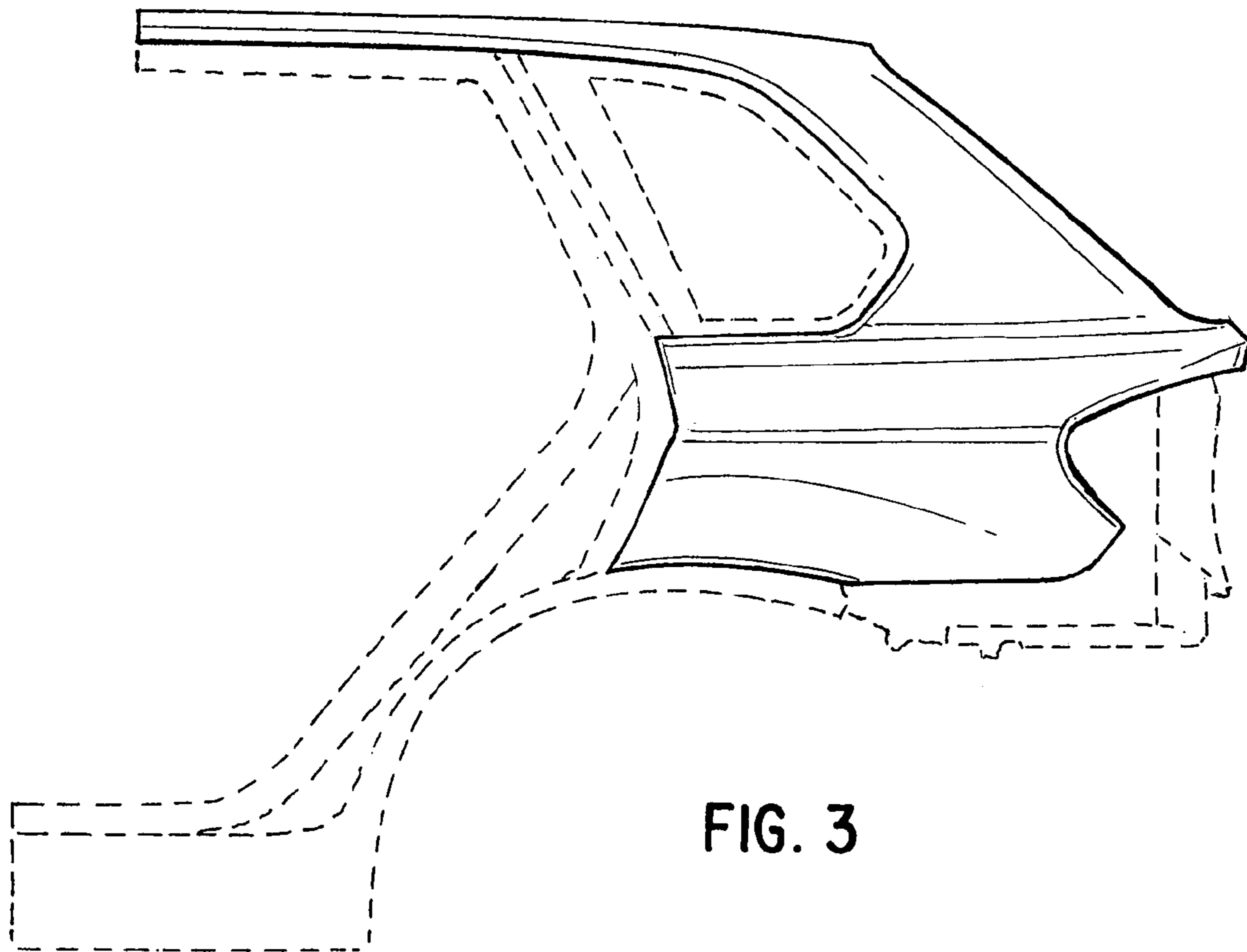

FIG. 3

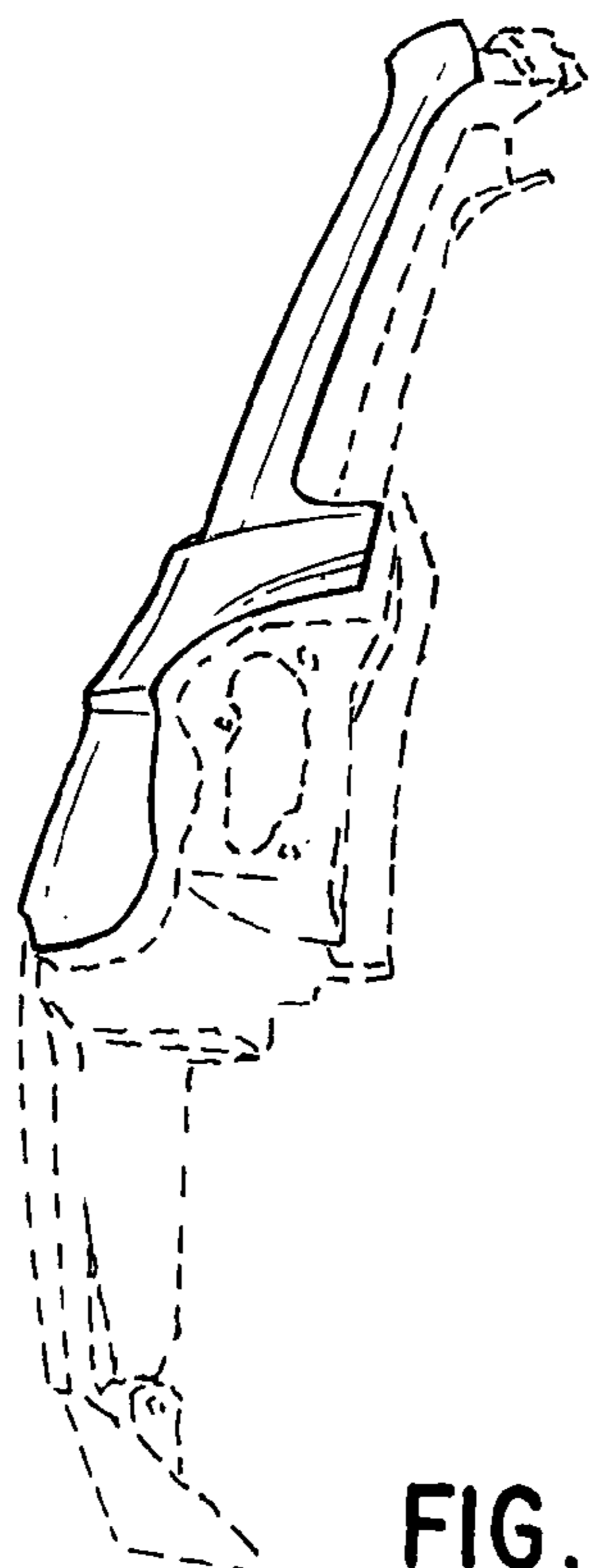

FIG. 4

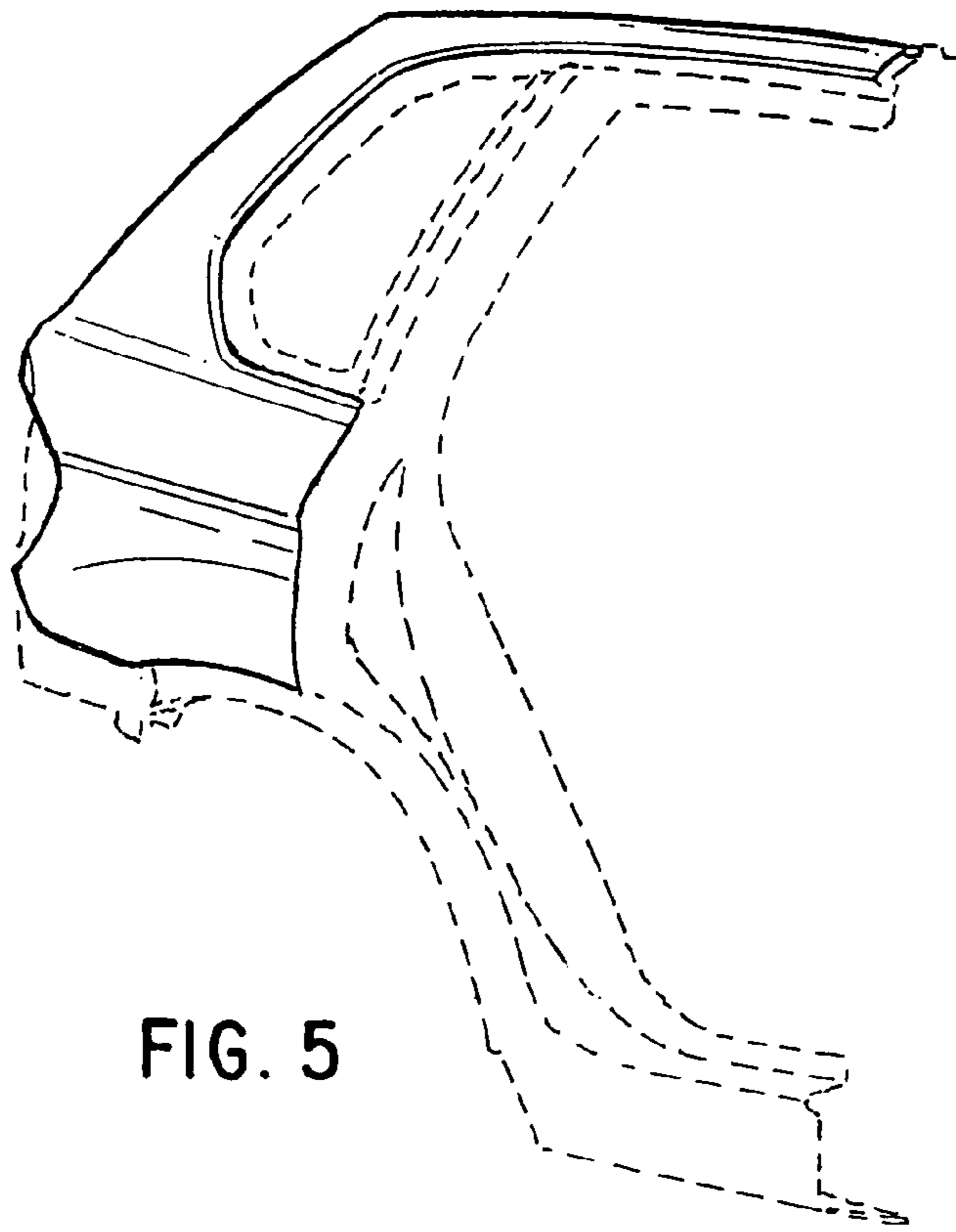

FIG. 5

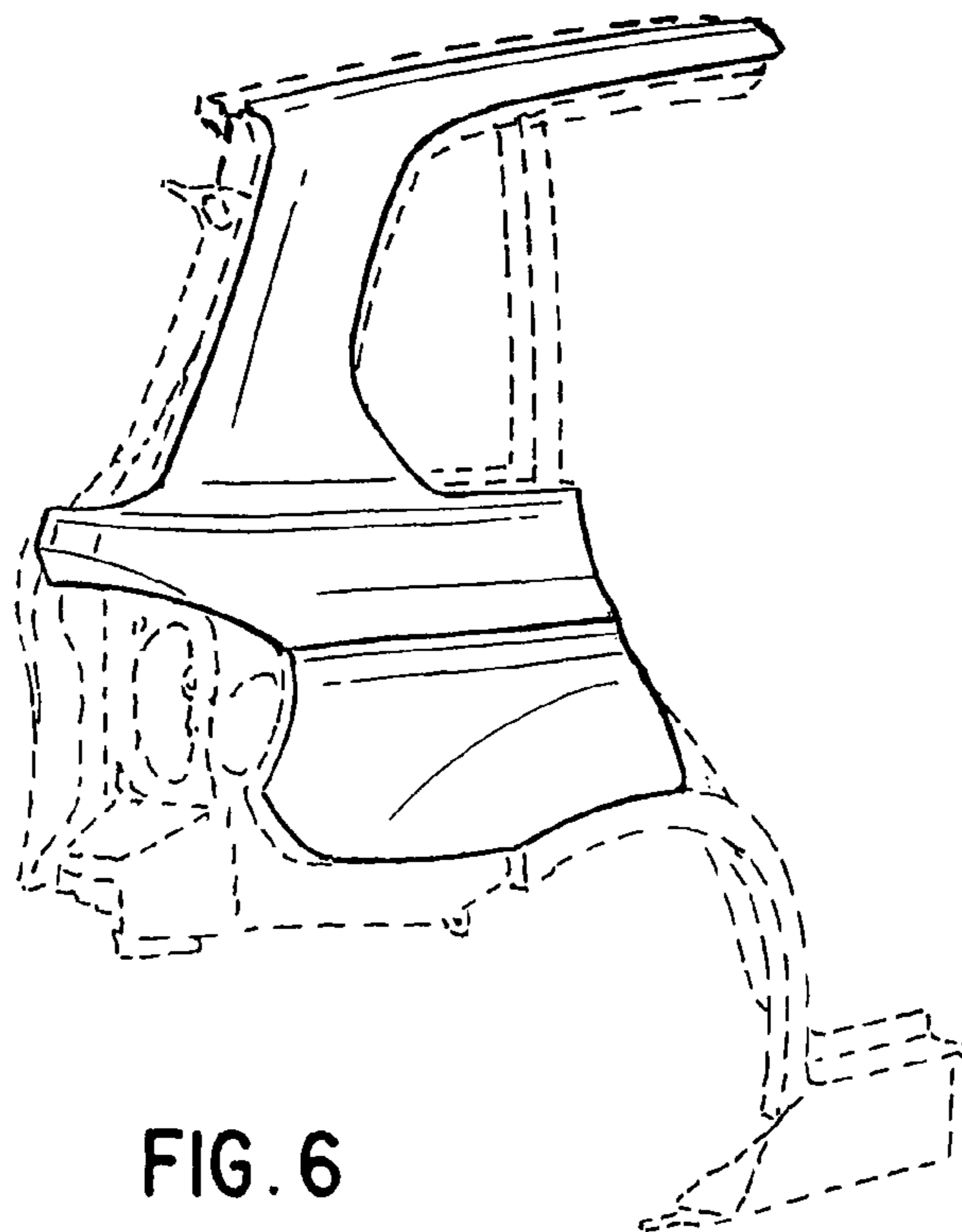

FIG. 6

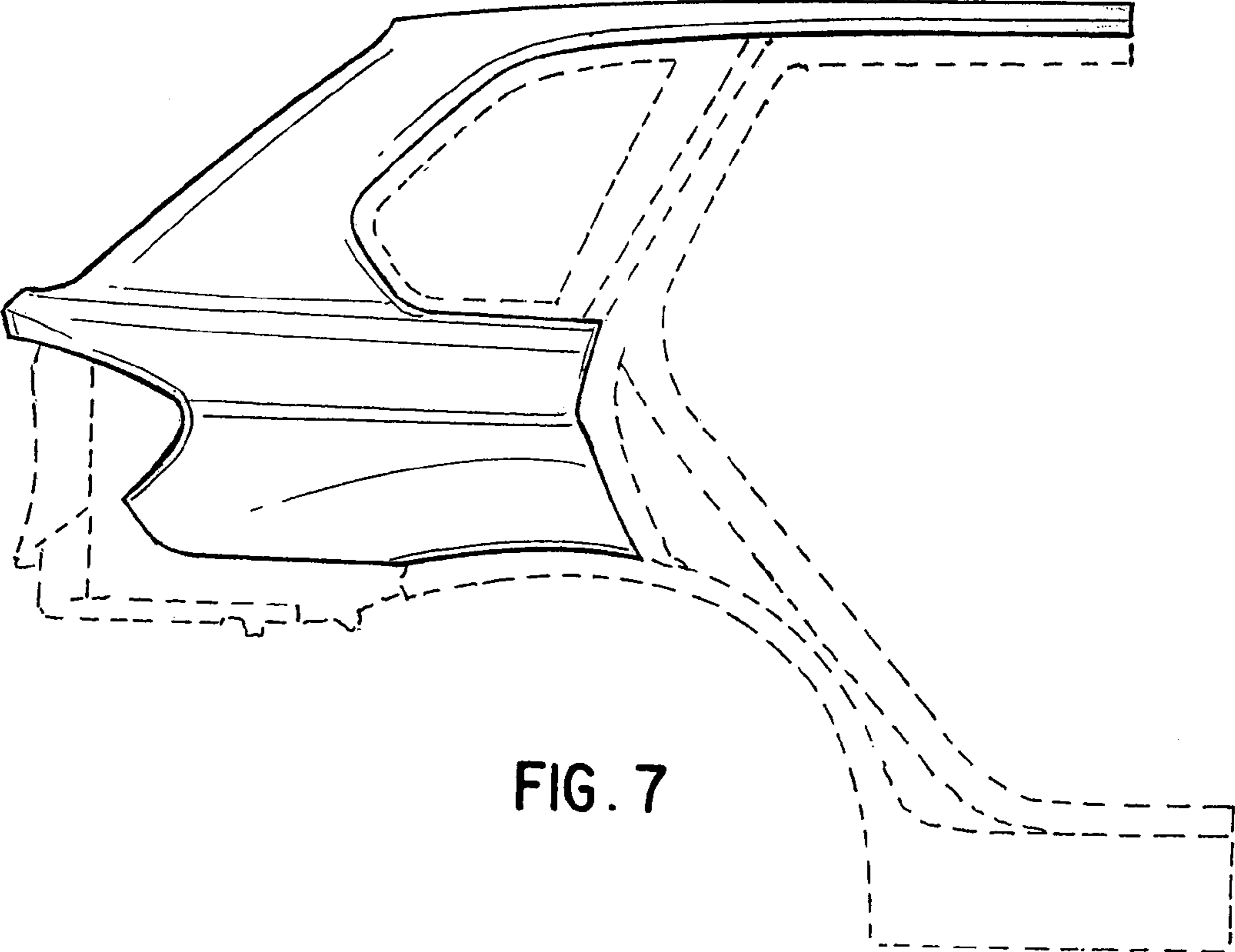

FIG. 7

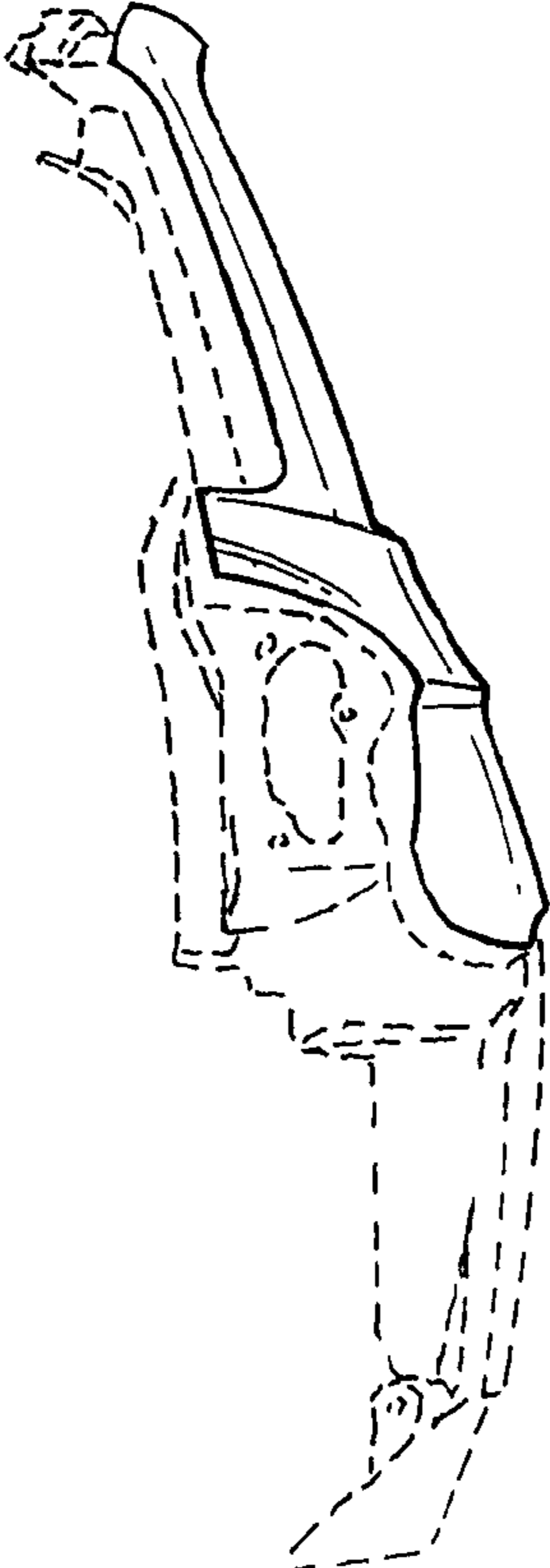

FIG. 8