

US00D558643S

(12) **United States Design Patent**
Beigel et al.

(10) **Patent No.:** **US D558,643 S**

(45) **Date of Patent:** **** Jan. 1, 2008**

(54) **TRUCK VEHICLE**

(75) Inventors: **David J. Beigel**, Payne, OH (US); **L. David Allendorph**, Fort Wayne, IN (US); **Craig L. Randolph**, Fort Wayne, IN (US); **Floyd A. Etzler**, Convoy, OH (US); **Jerry J. Connett**, Fort Wayne, IN (US); **Kris K. Timmerman**, Huntertown, IN (US); **Craig S. Tsukayama**, Fort Wayne, IN (US); **Ronald F. Mitchell**, Taylor, MI (US); **Franz Mueller**, Fort Wayne, IN (US); **Charles W. Kipfer**, Payne, OH (US); **Sunil K. Jain**, Fort Wayne, IN (US); **Travis E. Dennison**, Fort Wayne, IN (US); **James P. Pennell**, Naples, FL (US); **James M. Oleson**, Palm Coast, FL (US); **Eric J. Ognian**, Canton, MI (US); **Eric A. Magda**, Milan, MI (US); **Michael F. Mazziotti**, Farmington Hills, MI (US)

(73) Assignee: **International Truck and Engine Corporation Canada**, Warrenville, IL (US)

(**) Term: **14 Years**

(21) Appl. No.: **29/233,161**

(22) Filed: **Jun. 28, 2005**

(51) **LOC (8) Cl.** **12-16**

(52) **U.S. Cl.** **D12/96**

(58) **Field of Classification Search** D12/96,
D12/93; 296/190.1-190.3; D34/34-37; D15/23,
D15/25

See application file for complete search history.

(56) **References Cited**

U.S. PATENT DOCUMENTS

D401,198 S 11/1998 Mueller et al.

D409,965 S 5/1999 Mueller et al.
D416,221 S * 11/1999 Sutton et al. D12/196
D433,966 S * 11/2000 Beigel D12/96
D437,574 S 2/2001 Beigel
D442,898 S 5/2001 Beigel
D445,073 S 7/2001 Tirey et al.
D445,361 S 7/2001 Tirey et al.
D445,384 S 7/2001 Tirey et al.
D447,099 S 8/2001 Tirey et al.
D452,464 S 12/2001 Beigel
6,364,389 B1 4/2002 Beigel
D460,023 S 7/2002 Beigel
D465,749 S 11/2002 Beigel
D525,567 S * 7/2006 Beigel et al. D12/96

* cited by examiner

Primary Examiner—Melody N. Brown

(74) *Attorney, Agent, or Firm*—Gerald W. Askew; Jeffrey P. Calfa; Susan L. Lukasik

(57) **CLAIM**

The ornamental design for a truck vehicle, as shown and described.

DESCRIPTION

FIG. 1 is a left, front perspective view of a truck vehicle showing our new design, it may be understood that the broken lines are for illustrative purposes only and form no part of the claimed design;

FIG. 2 is a front view thereof, it may be understood that the broken lines are for illustrative purposes only and form no part of the claimed design;

FIG. 3 is a top view thereof, it may be understood that the broken lines are for illustrative purposes only and form no part of the claimed design;

FIG. 4 is a left view thereof, it may be understood that the broken lines are for illustrative purposes only and form no part of the claimed design; and,

FIG. 5 is a rear view thereof, it may be understood that the broken lines are for illustrative purposes only and form no part of the claimed design.

1 Claim, 5 Drawing Sheets





FIG. 1

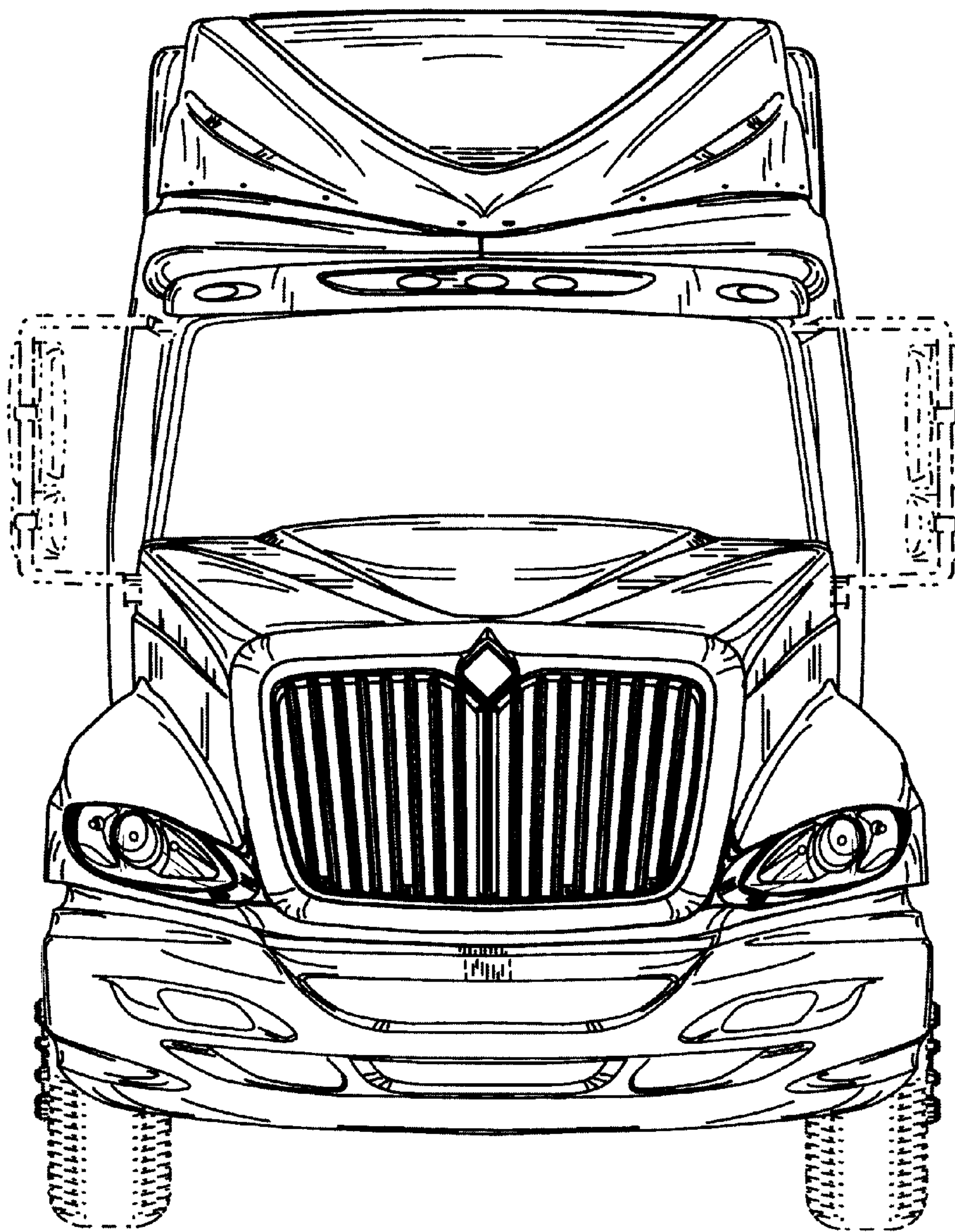

FIG. 2

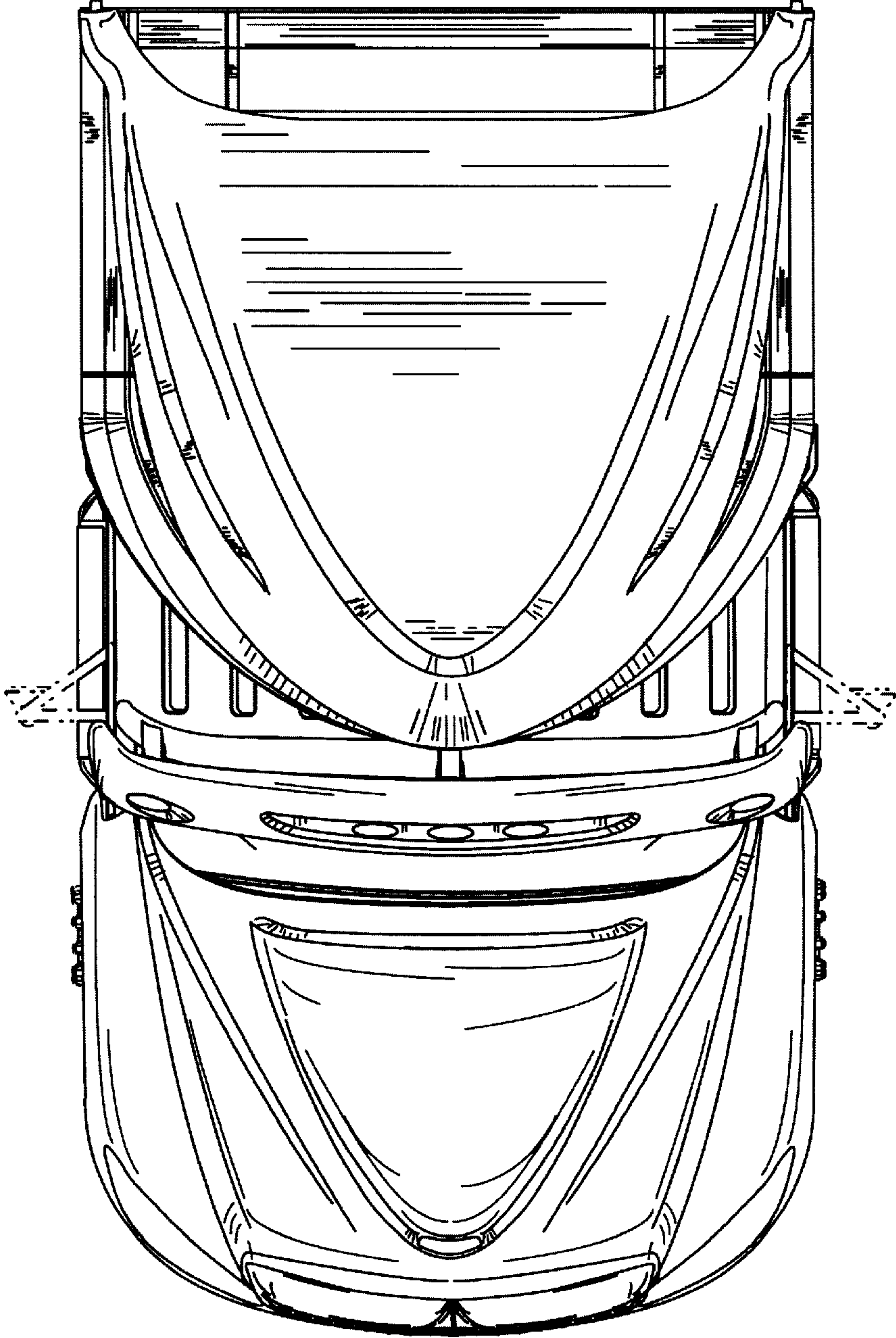

FIG. 3

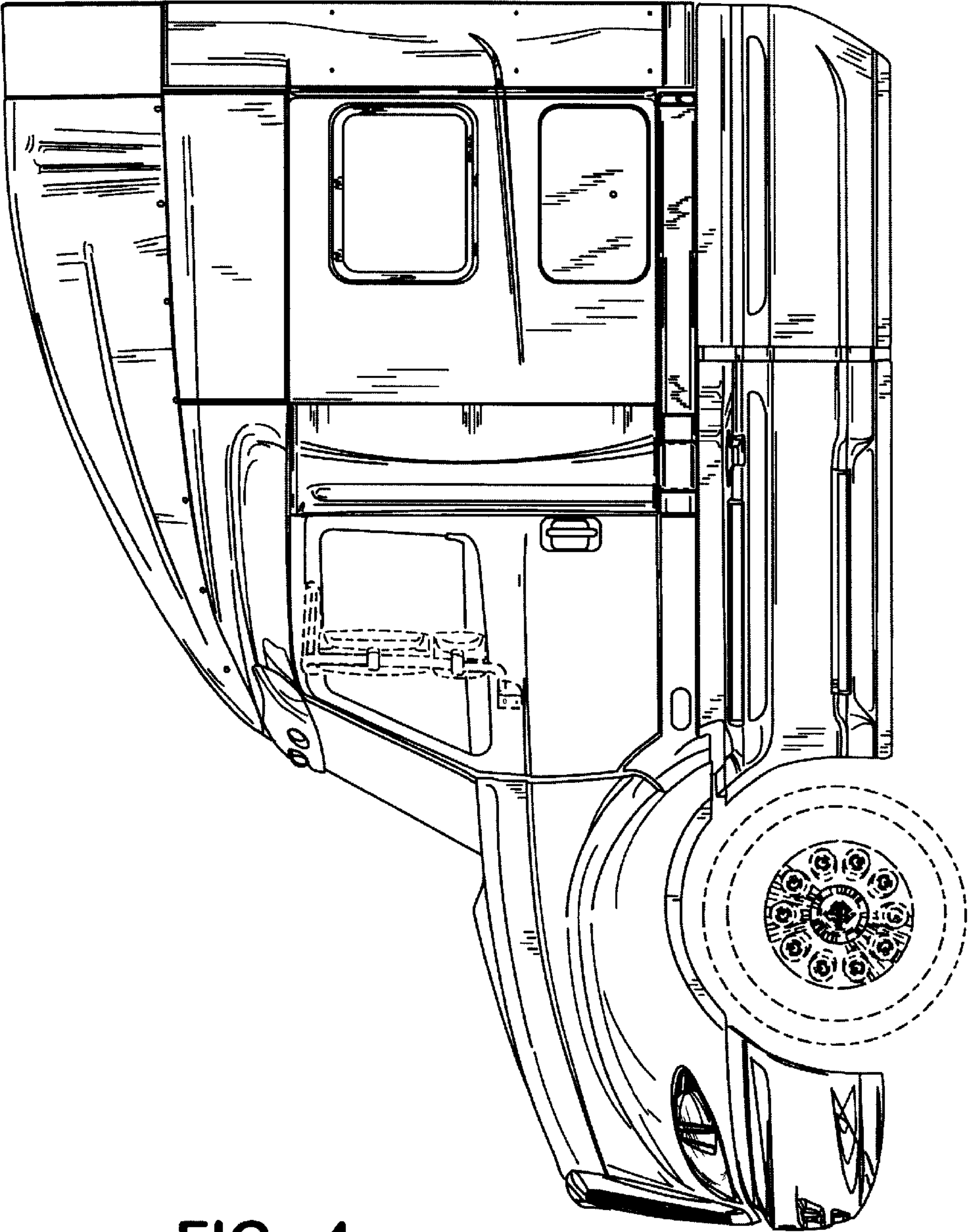

FIG. 4

FIG. 5

