



US00D558551S

(12) **United States Design Patent**
Okuda et al.

(10) **Patent No.:** **US D558,551 S**
(45) **Date of Patent:** **** Jan. 1, 2008**

(54) **PORTABLE ELECTRIC HAMMER DRILL**

(75) Inventors: **Shinsuke Okuda**, Anjo (JP); **Kiyonobu Yoshikane**, Anjo (JP)

(73) Assignee: **Makita Corporation**, Anjo-Shi (JP)

(**) Term: **14 Years**

(21) Appl. No.: **29/272,806**

(22) Filed: **Feb. 20, 2007**

(30) **Foreign Application Priority Data**

Sep. 26, 2006 (JP) 2006-025692

(51) **LOC (8) Cl.** **08-01**

(52) **U.S. Cl.** **D8/69**

(58) **Field of Classification Search** D8/14.1,
D8/61-70; 81/57.11, 429, 454-456, 469,
81/489; 173/13, 104, 114, 168-171, 178,
173/201, 211, 213, 217; 408/20, 124, 125,
408/234, 241 R; 451/358; 310/50; 227/8,
227/113, 114, 120, 130, 136, 142

See application file for complete search history.

(56) **References Cited**

U.S. PATENT DOCUMENTS

D378,654 S * 4/1997 Matsuoka et al. D8/69
D396,789 S * 8/1998 Murray D8/68
6,543,549 B1 * 4/2003 Riedl et al. 310/50
D538,619 S * 3/2007 Okuda D8/69

D540,135 S * 4/2007 Okuda D8/68
2003/0094294 A1 * 5/2003 Fritz 173/171
2006/0000627 A1 * 1/2006 Frauhammer et al. 173/217

FOREIGN PATENT DOCUMENTS

GB 2105552 S * 10/2001
GB 3011894 S * 3/2003
JP S 1280931 9/2006
JP S 1280952 9/2006

* cited by examiner

Primary Examiner—T. Chase Nelson

(74) *Attorney, Agent, or Firm*—Oliff & Berridge, PLC

(57) **CLAIM**

The ornamental design for a portable electric hammer drill, as shown and described.

DESCRIPTION

FIG. 1 is a perspective view of top, front and right side of a portable electronic hammer drill showing our new design; FIG. 2 is a right side view thereof; FIG. 3 is a left side view thereof; FIG. 4 is a front view thereof; FIG. 5 is a rear view thereof; FIG. 6 is a top plan view thereof; and, FIG. 7 is a bottom view thereof.

1 Claim, 5 Drawing Sheets

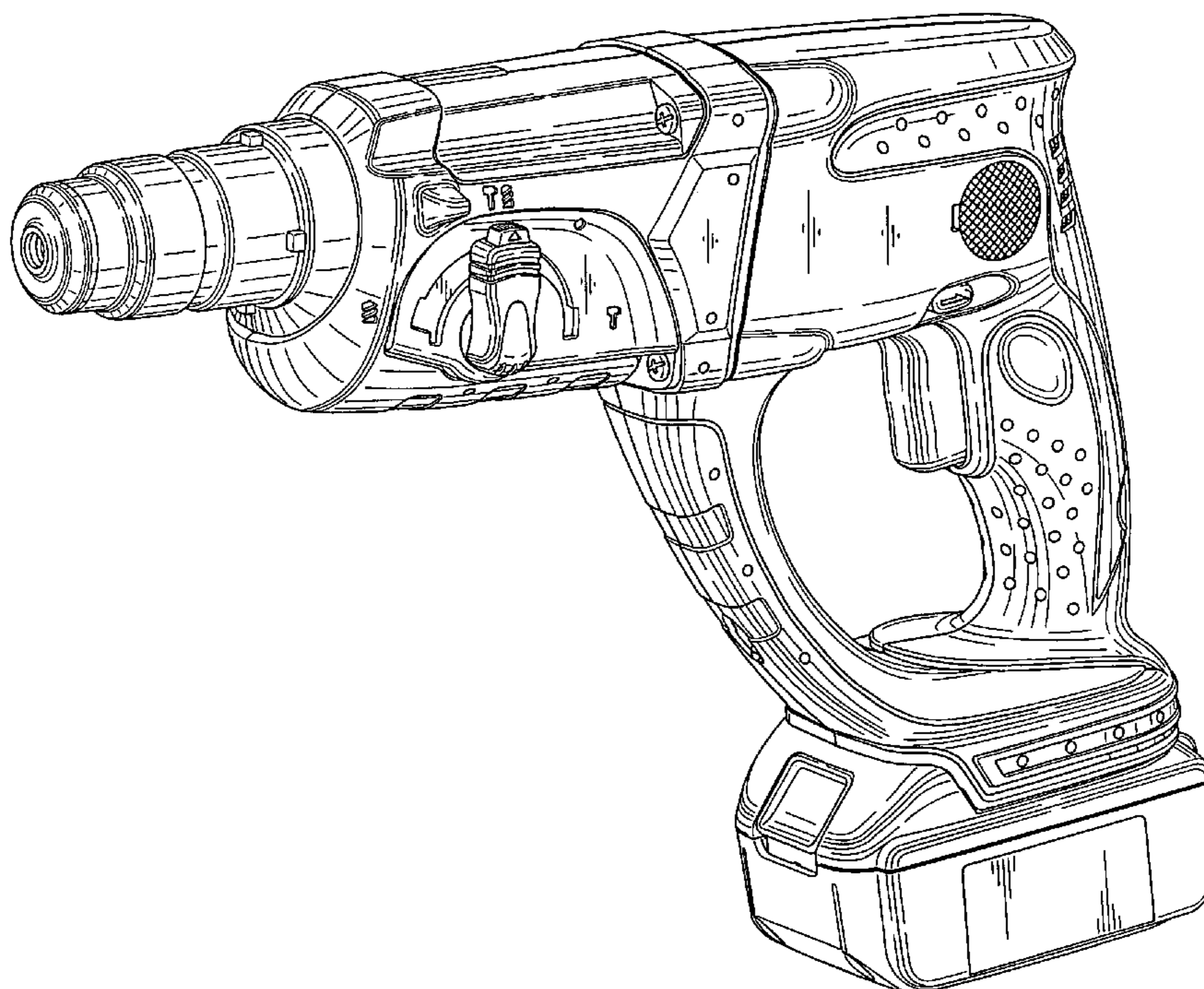

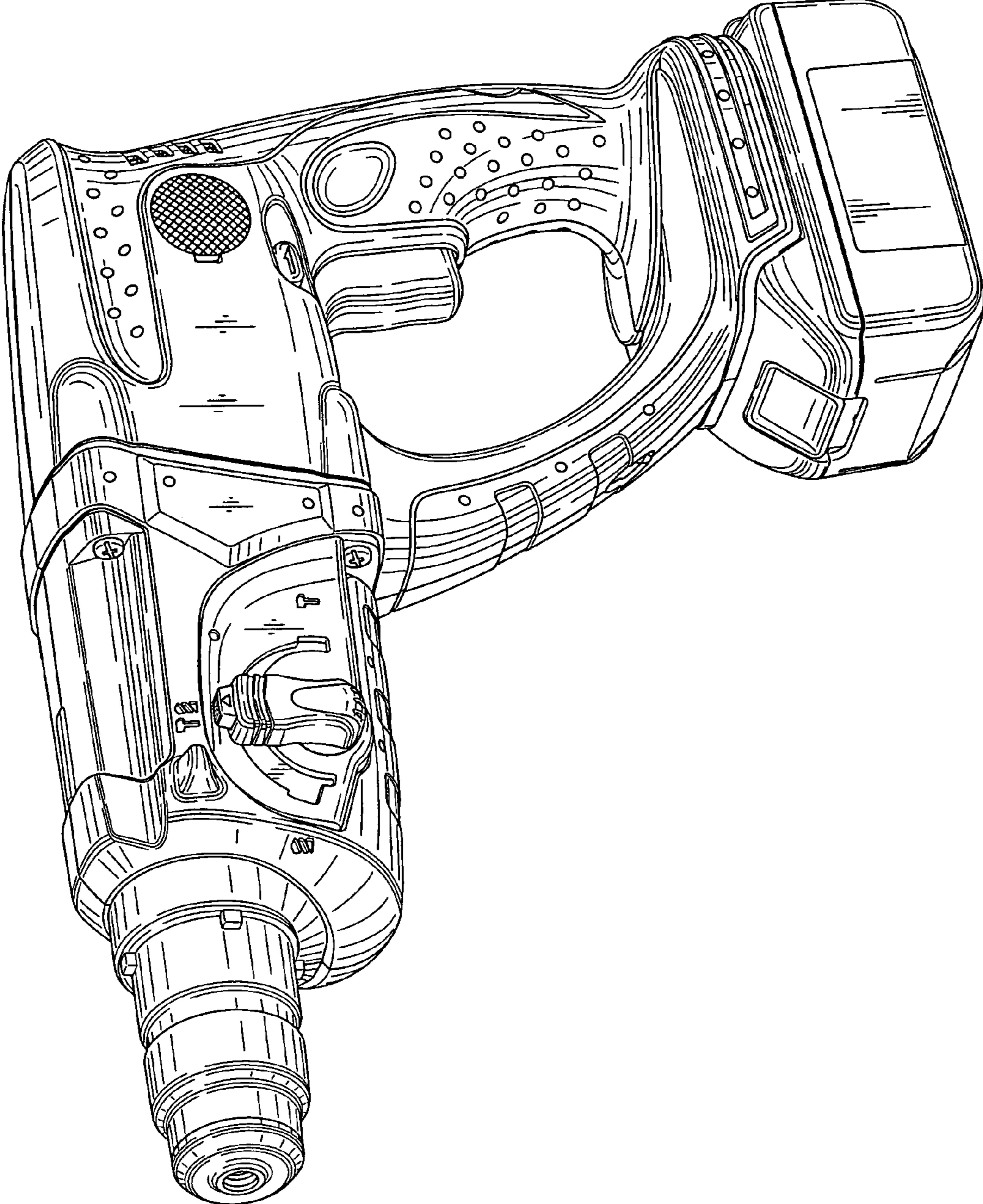

FIG. 1

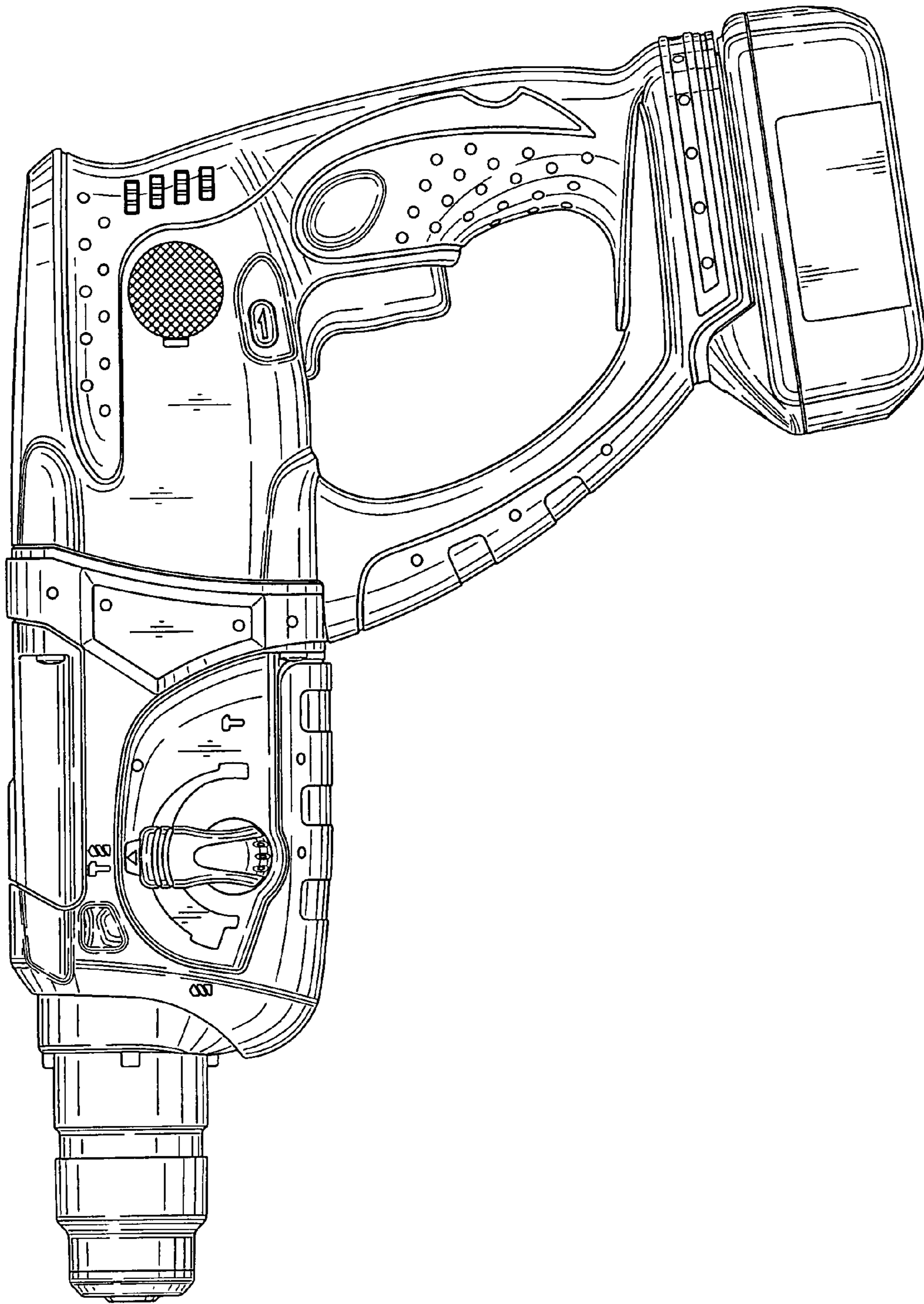

FIG. 2

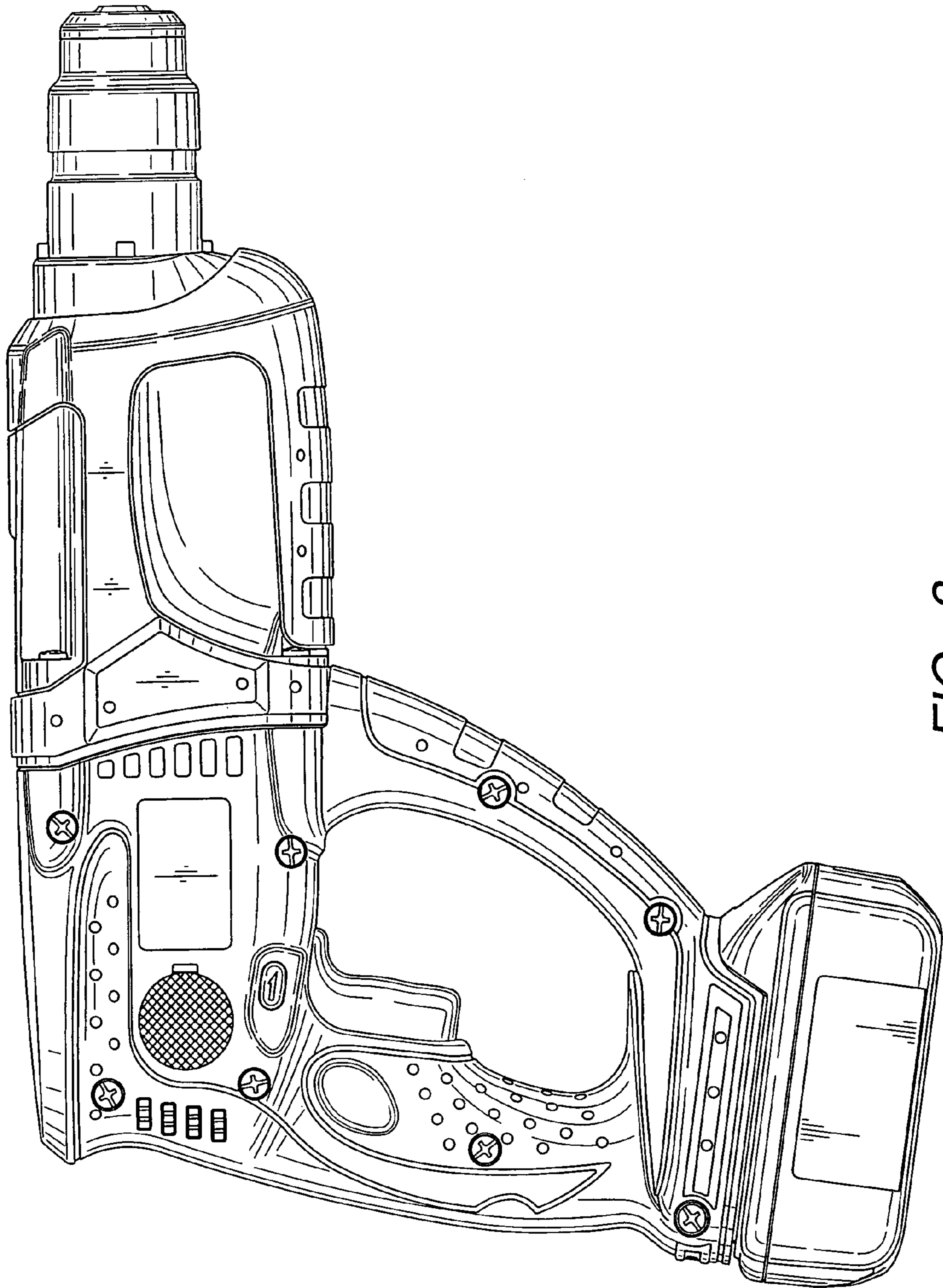

FIG. 3

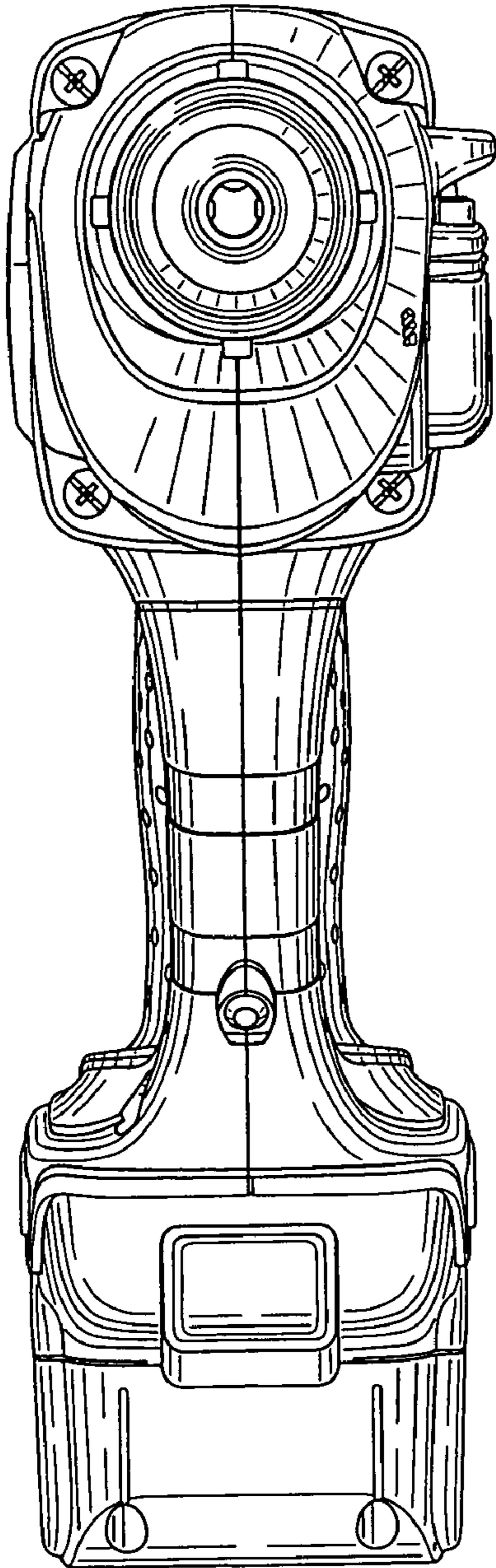

FIG. 4

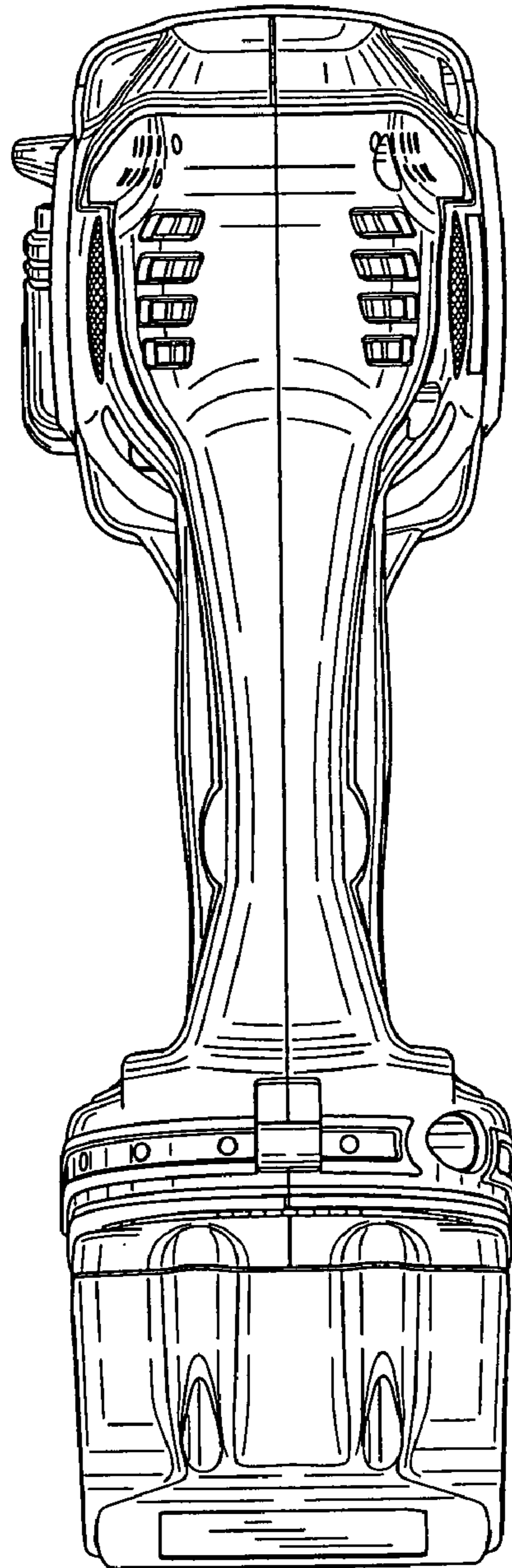

FIG. 5

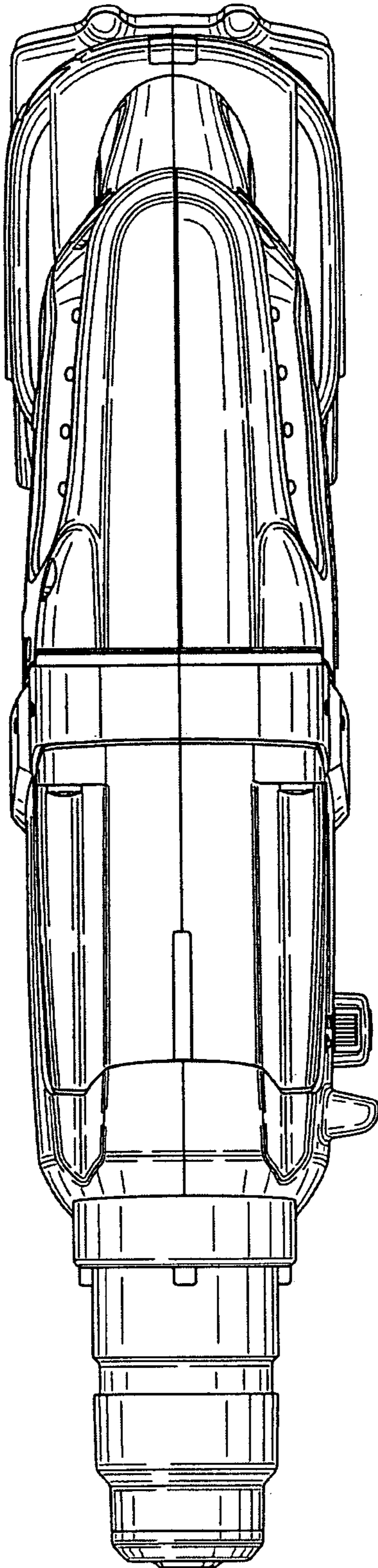

FIG. 6

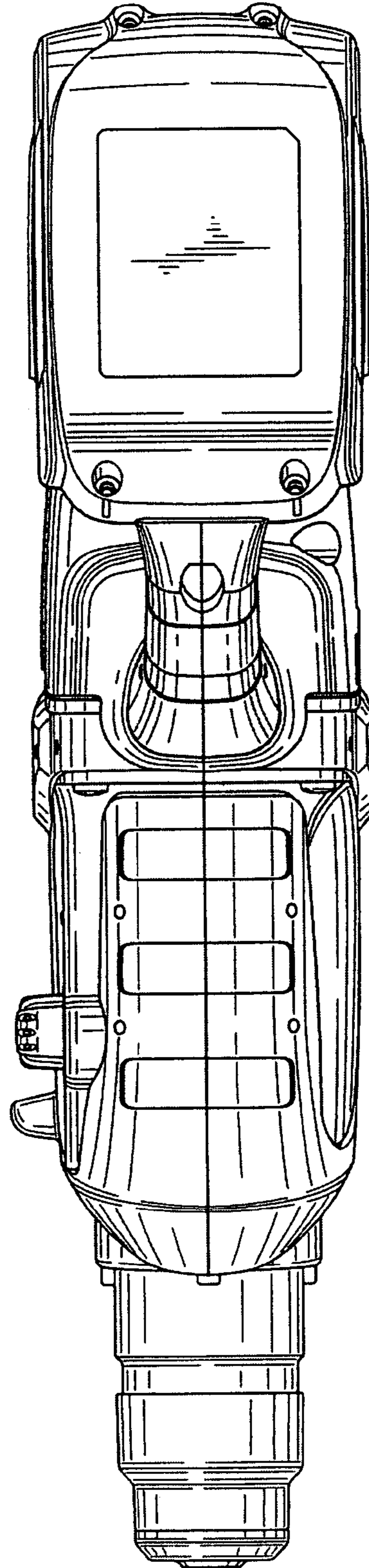

FIG. 7