



US00D558368S

(12) **United States Design Patent**
Koyama

(10) **Patent No.:** **US D558,368 S**

(45) **Date of Patent:** **** Dec. 25, 2007**

(54) **REAR COMBINATION LAMP FOR AN
AUTOMOBILE**

D506,842 S * 6/2005 Nagura et al. D26/28
D526,428 S * 8/2006 Yagihashi D26/28
D542,443 S * 5/2007 Matsunami D26/28

(75) Inventor: **Gou Koyama**, Saitama (JP)

* cited by examiner

(73) Assignee: **Honda Motor Co., Ltd.**, Tokyo (JP)

Primary Examiner—Marcus A. Jackson

(**) Term: **14 Years**

(74) *Attorney, Agent, or Firm*—Westerman, Hattori, Daniels
& Adrian, LLP.

(21) Appl. No.: **29/281,200**

(57) **CLAIM**

(22) Filed: **Jun. 18, 2007**

What is claimed is; the ornamental design for, a rear
combination lamp for an automobile, as shown and
described.

(30) **Foreign Application Priority Data**

Dec. 21, 2006 (JP) 2006-035114

DESCRIPTION

(51) **LOC (8) Cl.** **26-06**

(52) **U.S. Cl.** **D26/28**

(58) **Field of Classification Search** D26/28-36;
362/459-468, 475-478, 485-487
See application file for complete search history.

FIG. 1 is a perspective view of a rear combination lamp for
an automobile, showing our new design;
FIG. 2 is a front elevation view thereof;
FIG. 3 is a top plan view thereof; and,
FIG. 4 is a right side elevation view thereof.

The broken lines are for illustrative purposes only and form
no part of the claimed design.

(56) **References Cited**

U.S. PATENT DOCUMENTS

D476,758 S * 7/2003 Lin D26/28
D481,476 S * 10/2003 Liu D26/28
D489,835 S * 5/2004 Lin D26/28

1 Claim, 4 Drawing Sheets

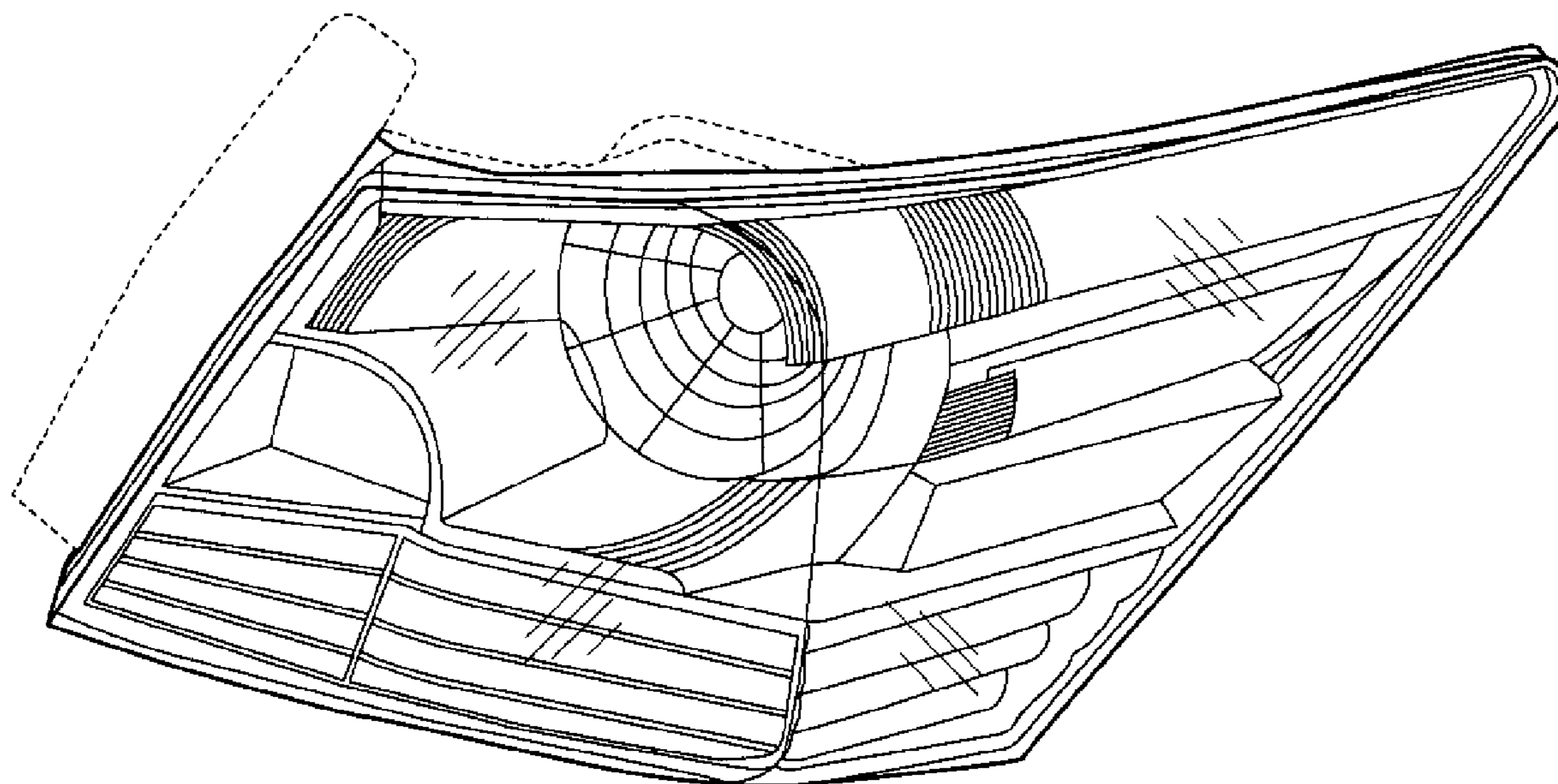

Fig.1

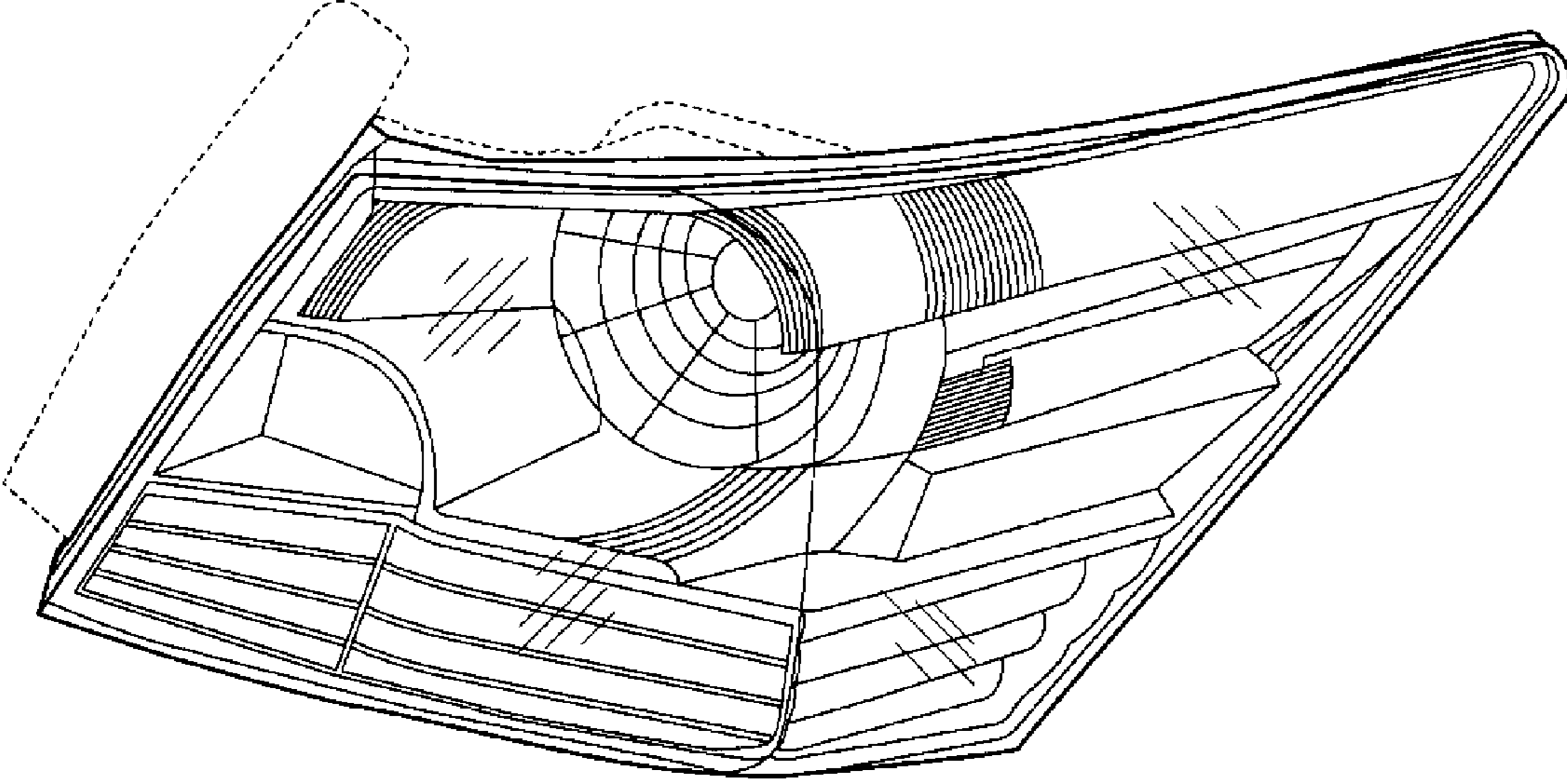

Fig.2

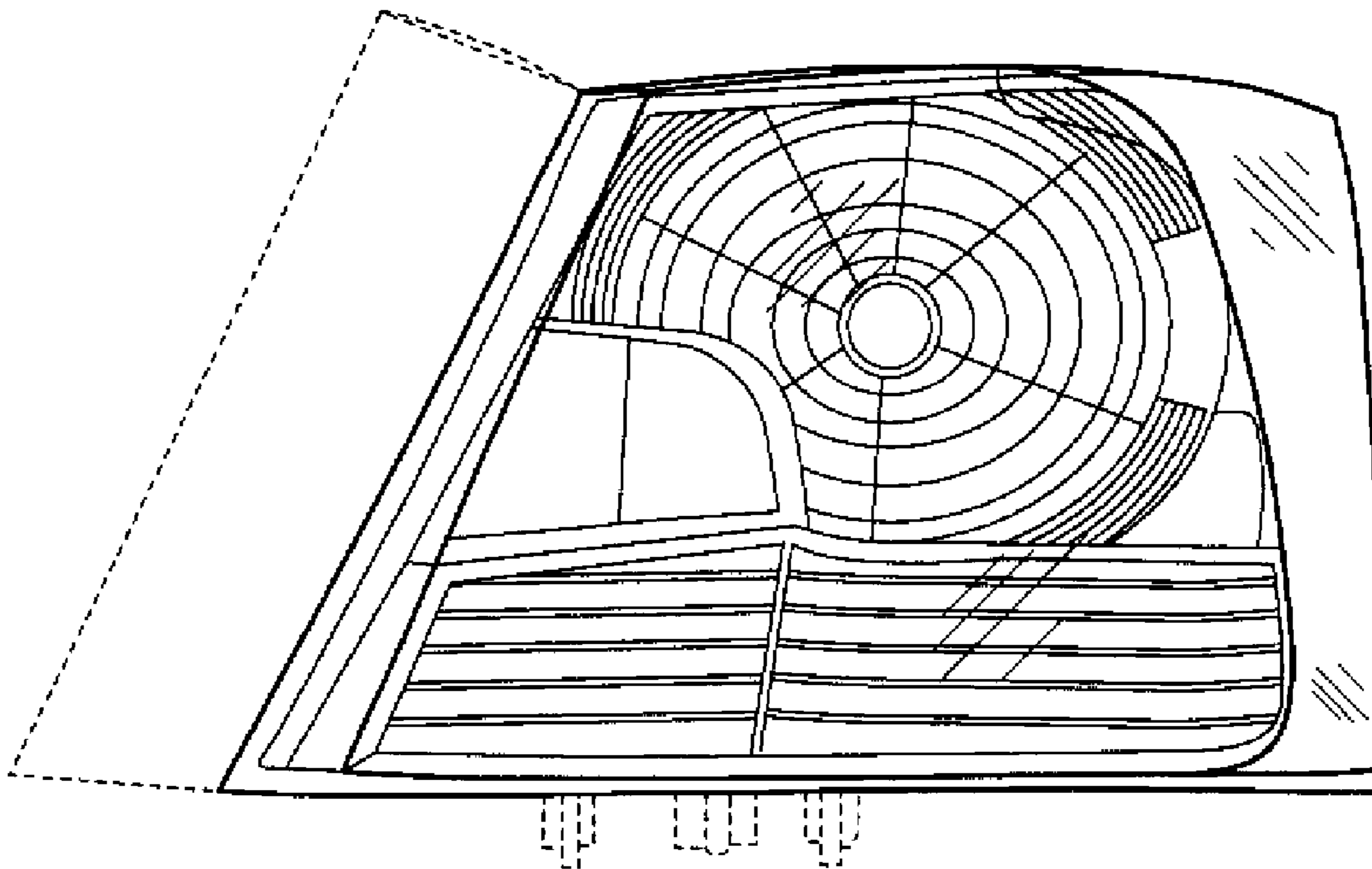

Fig.3

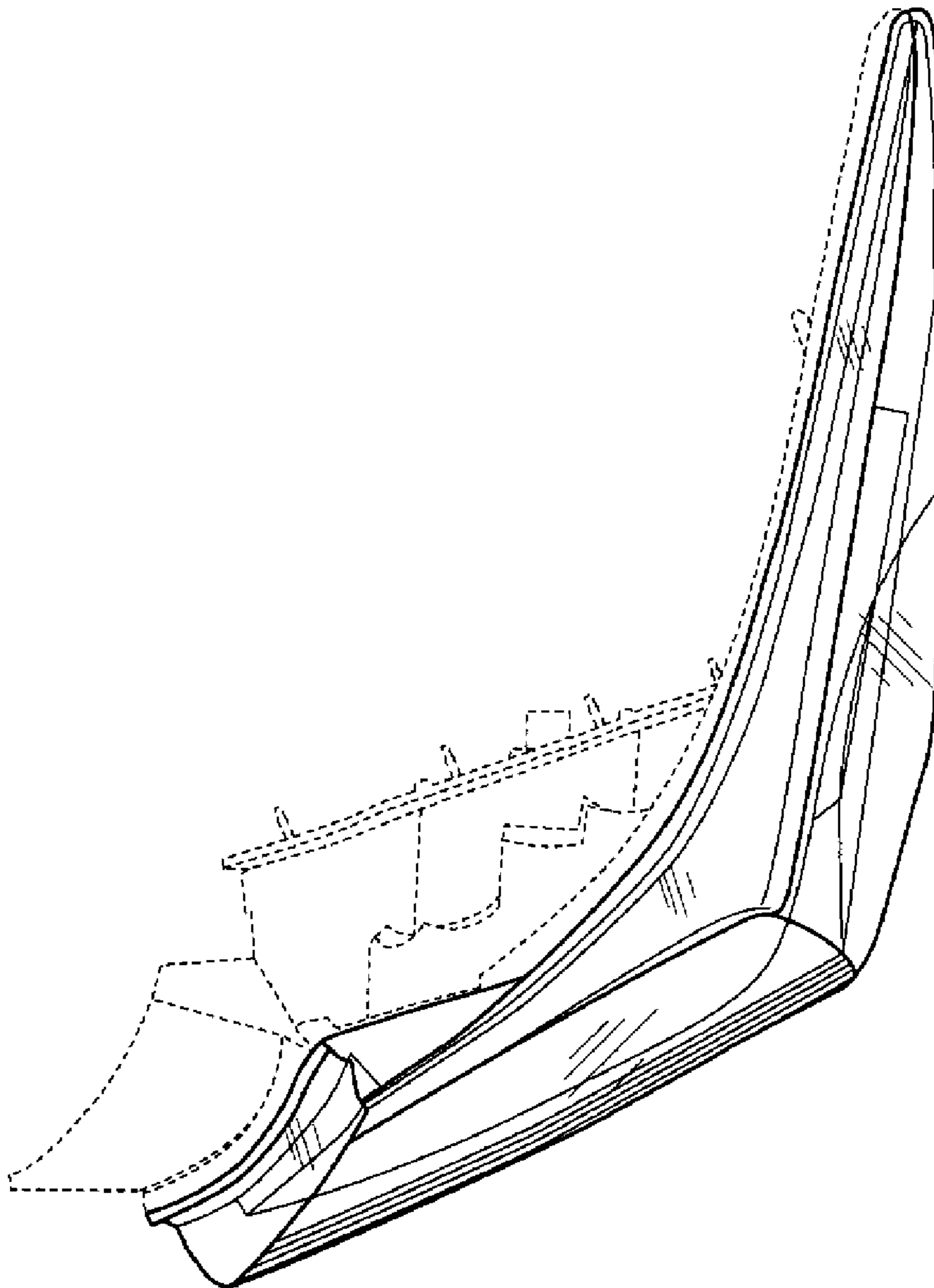

Fig.4

