



US00D558286S

(12) **United States Design Patent** (10) **Patent No.:** **US D558,286 S**
Hoffman et al. (45) **Date of Patent:** **** Dec. 25, 2007**

(54) **GOLF CLUB HEAD**

(75) Inventors: **Joseph Henry Hoffman**, Carlsbad, CA (US); **Steven D. Gray**, Poway, CA (US); **Todd P. Beach**, San Diego, CA (US); **Robert Nunez**, San Pedro, CA (US); **Craig Kevin Barez**, Temecula, CA (US); **Thomas Olsavsky**, Oceanside, CA (US); **Sean Toulon**, Vista, CA (US)

(73) Assignee: **Taylor Made Golf Company, Inc.**, Carlsbad, CA (US)

(**) Term: **14 Years**

(21) Appl. No.: **29/268,247**

(22) Filed: **Oct. 31, 2006**

(51) **LOC (8) Cl.** **21-02**

(52) **U.S. Cl.** **D21/752**

(58) **Field of Classification Search** D21/733,

D21/752, 759; 473/324-331, 343-346

See application file for complete search history.

(56) **References Cited**

U.S. PATENT DOCUMENTS

| | | |
|------------|---------|---------------|
| D247,922 S | 5/1978 | Sheldon |
| D469,141 S | 1/2003 | Poynor et al. |
| D479,867 S | 9/2003 | Saliba et al. |
| D482,093 S | 11/2003 | Imamoto |
| D499,158 S | 11/2004 | Imamoto |
| D501,235 S | 1/2005 | Imamoto |
| D513,051 S | 12/2005 | Barez et al. |
| D514,185 S | 1/2006 | Barez et al. |
| D516,652 S | 3/2006 | Barez et al. |

(Continued)

OTHER PUBLICATIONS

“r5 Dual TI Fairway Woods,” TaylorMade 2005 Catalog #35767001, p. 10 (2005).

“r7 Fairway Woods,” TaylorMade 2005 Catalog #88357101, 3 pp. (2005).

“R5 Dual Driver Type D,” <http://www.tmgolfshop.com/r5d.html>, 1 p., printed Jul. 12, 2006.

“R5 Dual Driver Type N,” <http://www.tmgolfshop.com/r5n.html>, 1 p., printed Jul. 12, 2006.

“R7 Quad Driver,” <http://www.tmgolfshop.com/r7quad.html>, 2 pp., printed Jul. 12, 2006.

“R7 HT Quad Driver,” <http://www.tmgolfshop.com/r7quadht.html>, 2 pp., printed Jul. 12, 2006.

“TaylorMade R7 TP Fairway Wood,” <http://www.eprolinegolf.com/tayr7tpfw.aspx>, 2 pp., printed Jul. 13, 2006.

“TaylorMade r5 Dual Fairway Woods,” http://www.bhmgolf.com/desc.ydev?prod_id=8172, 2 pp., printed Jul. 13, 2006.

(Continued)

Primary Examiner—Mitchell Siegel

(74) *Attorney, Agent, or Firm*—Klarquist Sparkman, LLP

(57) **CLAIM**

We claim the ornamental design for a golf club head, as shown and described.

DESCRIPTION

FIG. 1 is a perspective view of a golf club head, as viewed from the rear, bottom and one side thereof, according to one embodiment.

FIG. 2 is a bottom plan view of the golf club head of FIG. 1.

FIG. 3 is a side elevation view of the heel of the golf club head of FIG. 1.

FIG. 4 is a side elevation view of the toe of the golf club head of FIG. 1.

FIG. 5 is a rear elevation view of the golf club head of FIG. 1.

FIG. 6 is a top plan view of the golf club head of FIG. 1; and, FIG. 7 is a front elevation view of the golf club head of FIG. 1.

The dashed lines in the drawings are for illustrative purpose only and form no part of the claimed design.

1 Claim, 3 Drawing Sheets

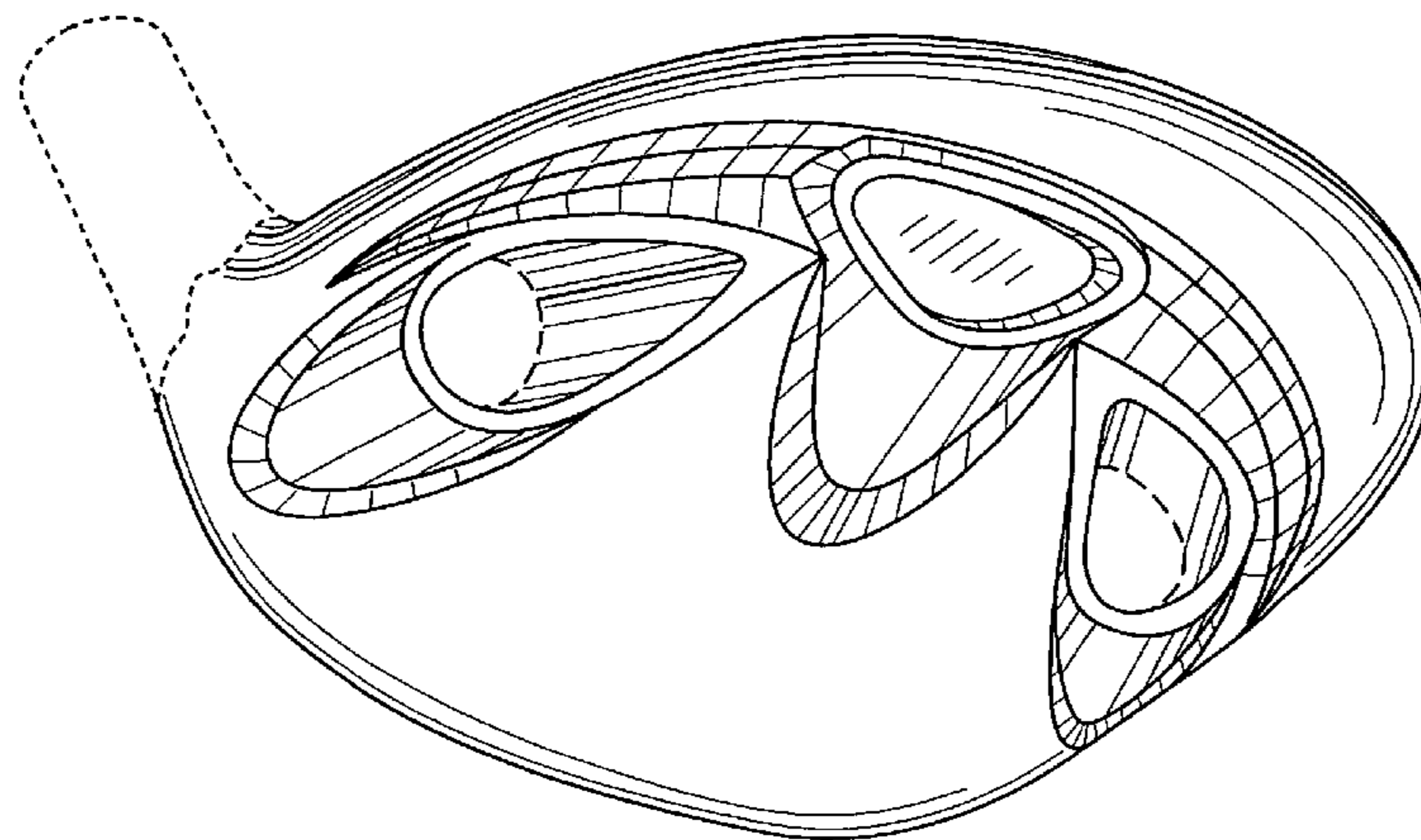

US D558,286 S

Page 2

U.S. PATENT DOCUMENTS

D518,129 S 3/2006 Poynor et al.
D519,177 S 4/2006 Barez et al.
D519,589 S 4/2006 Barez et al.
D520,090 S 5/2006 Imamoto
D520,586 S 5/2006 Bingman
D521,091 S 5/2006 Mahaffey et al.
D524,892 S 7/2006 Wilson et al.
D527,064 S 8/2006 Breier et al.
D533,611 S 12/2006 Mahaffey et al.
D534,229 S 12/2006 Barez et al.
D535,713 S * 1/2007 Barez et al. D21/752

D537,497 S * 2/2007 Hoffman et al. D21/752
D542,367 S * 5/2007 Hoffman et al. D21/759
D543,602 S * 5/2007 Hoffman et al. D21/759

OTHER PUBLICATIONS

“r5 dual Type N,” TaylorMade Rescue Dual Catalog #88357101, 3 pp., 2005.

“r7 TP Fairway Woods,” TaylorMade Rescue Dual Catalog #88357101, 3 pp., 2005.

“r7 Quad Driver,” TaylorMade 2005 Catalog #35767001, p. 3, 2005.

* cited by examiner

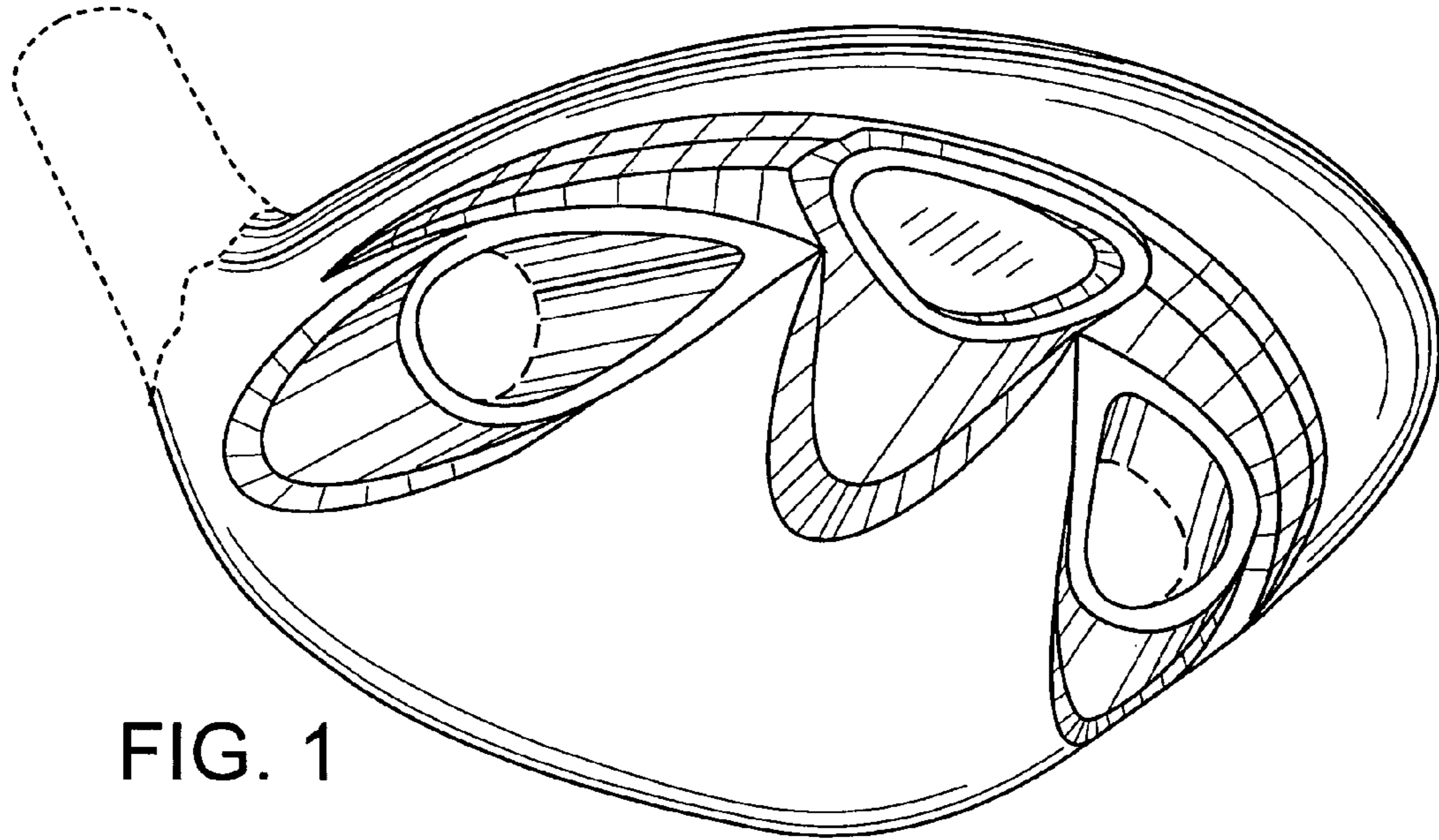

FIG. 1

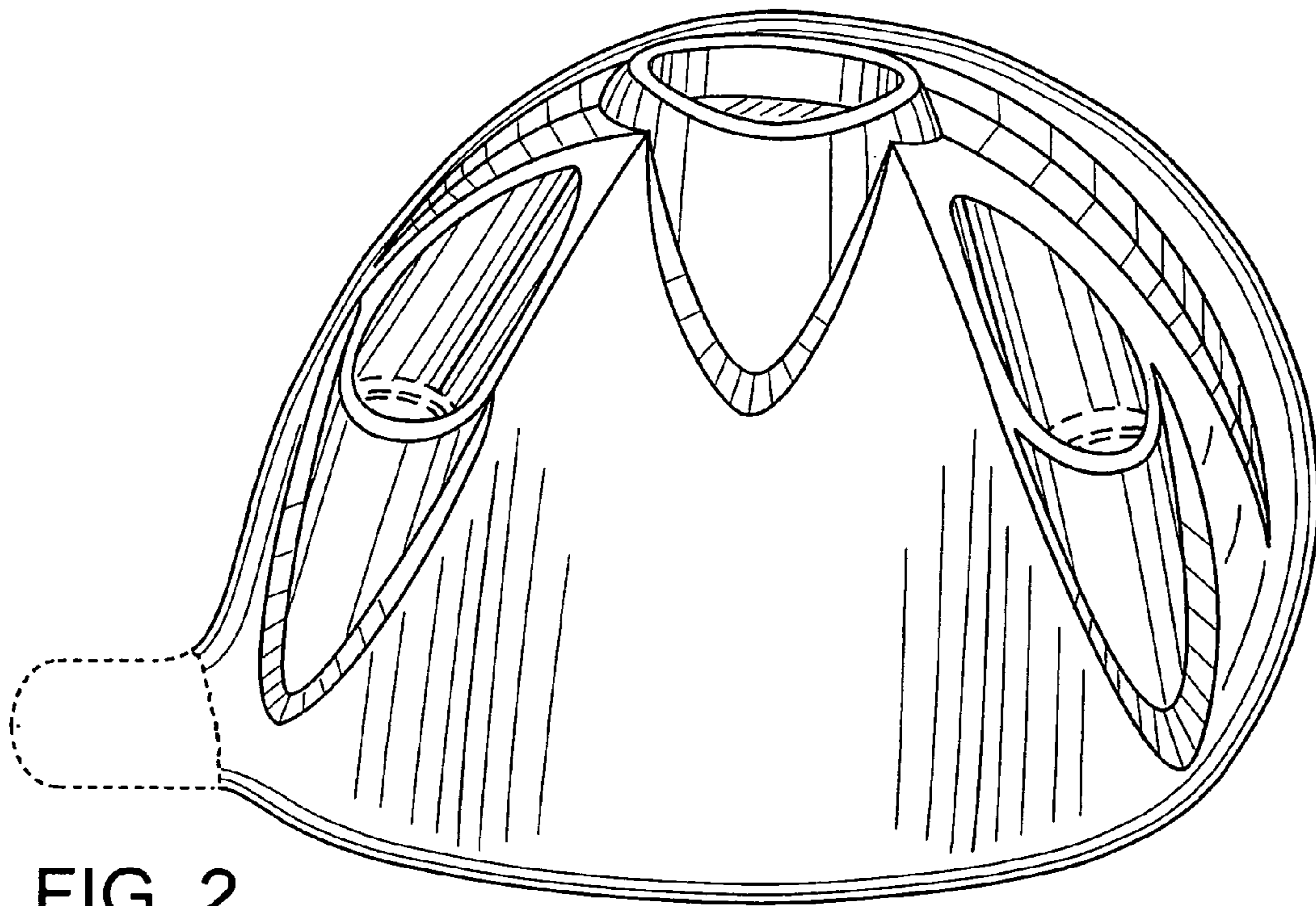

FIG. 2

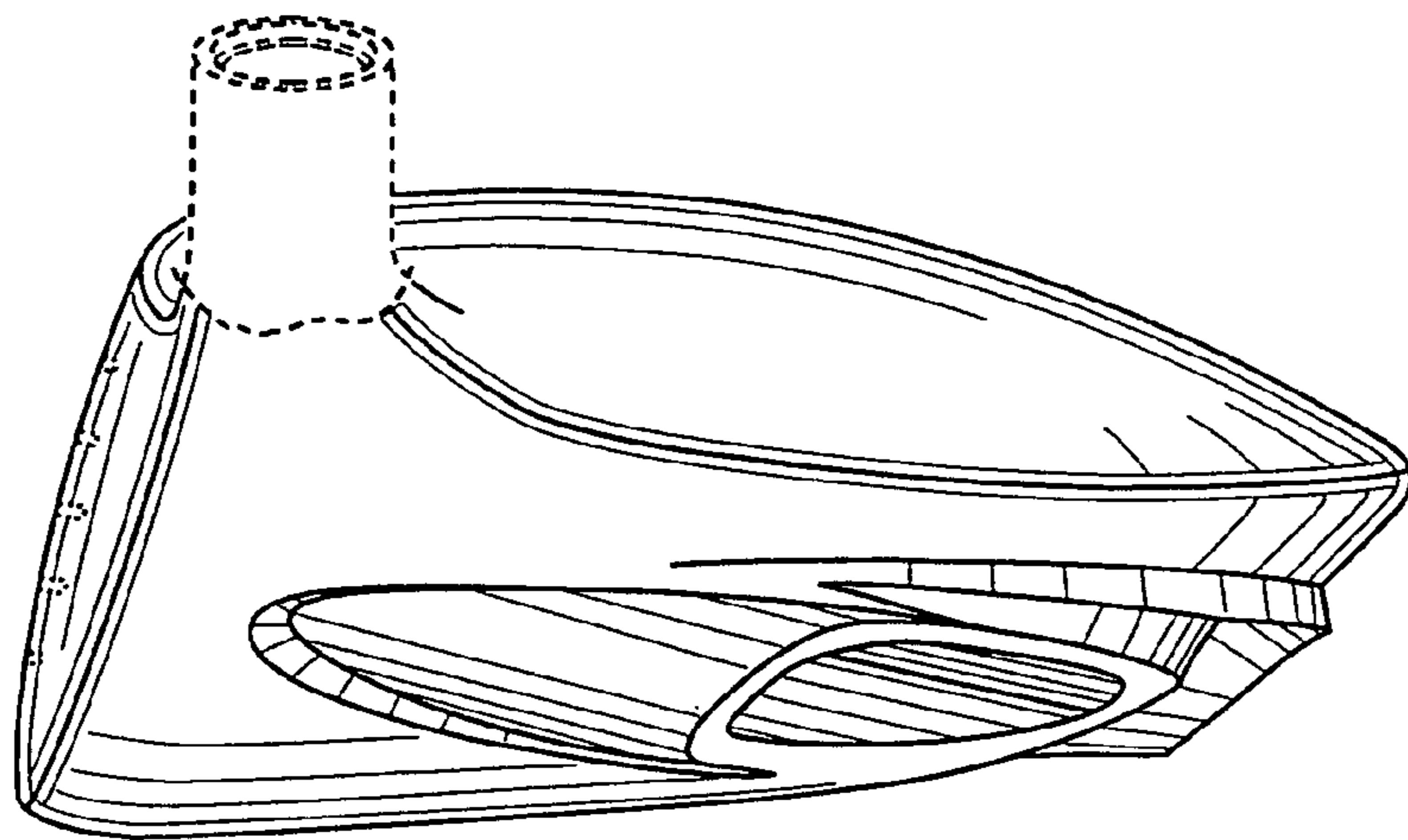

FIG. 3

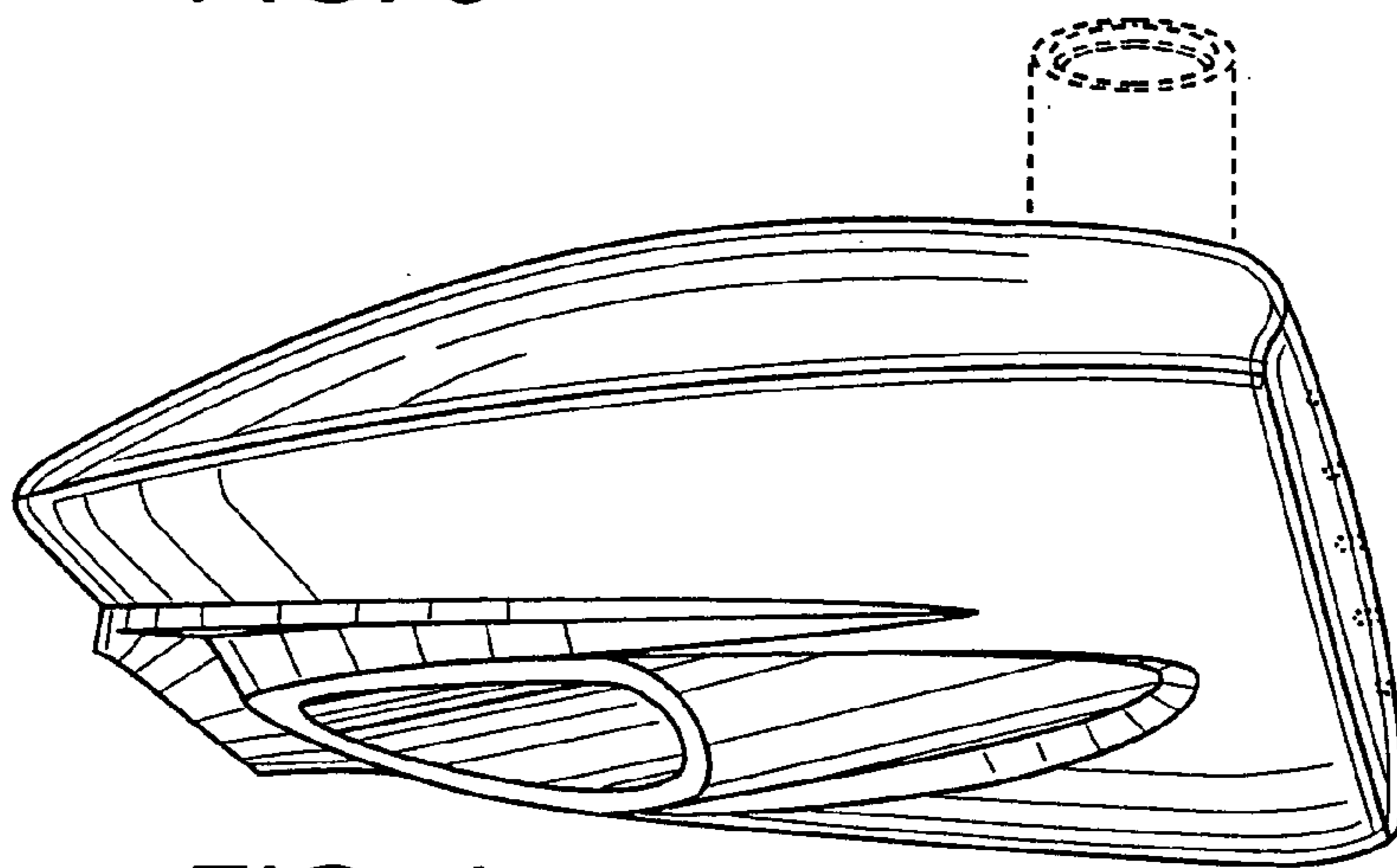

FIG. 4

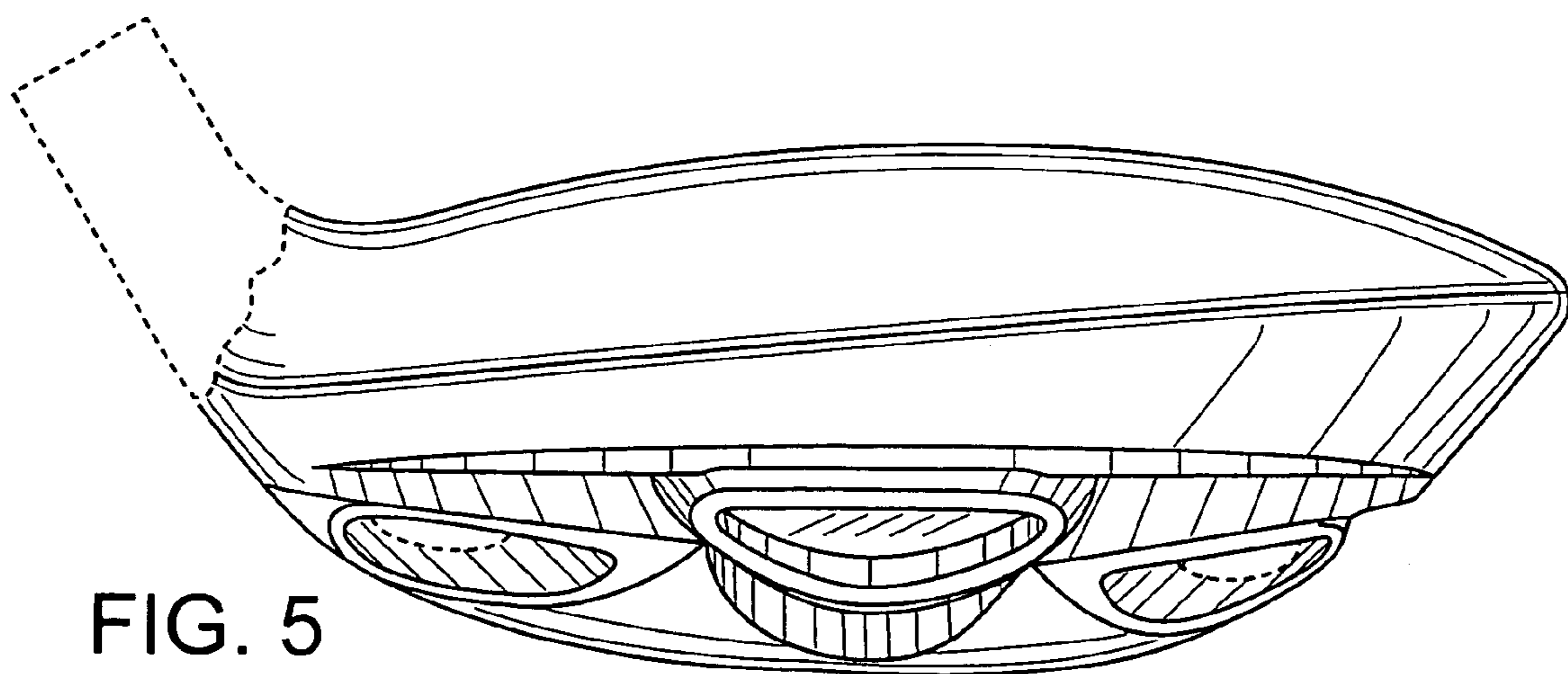

FIG. 5

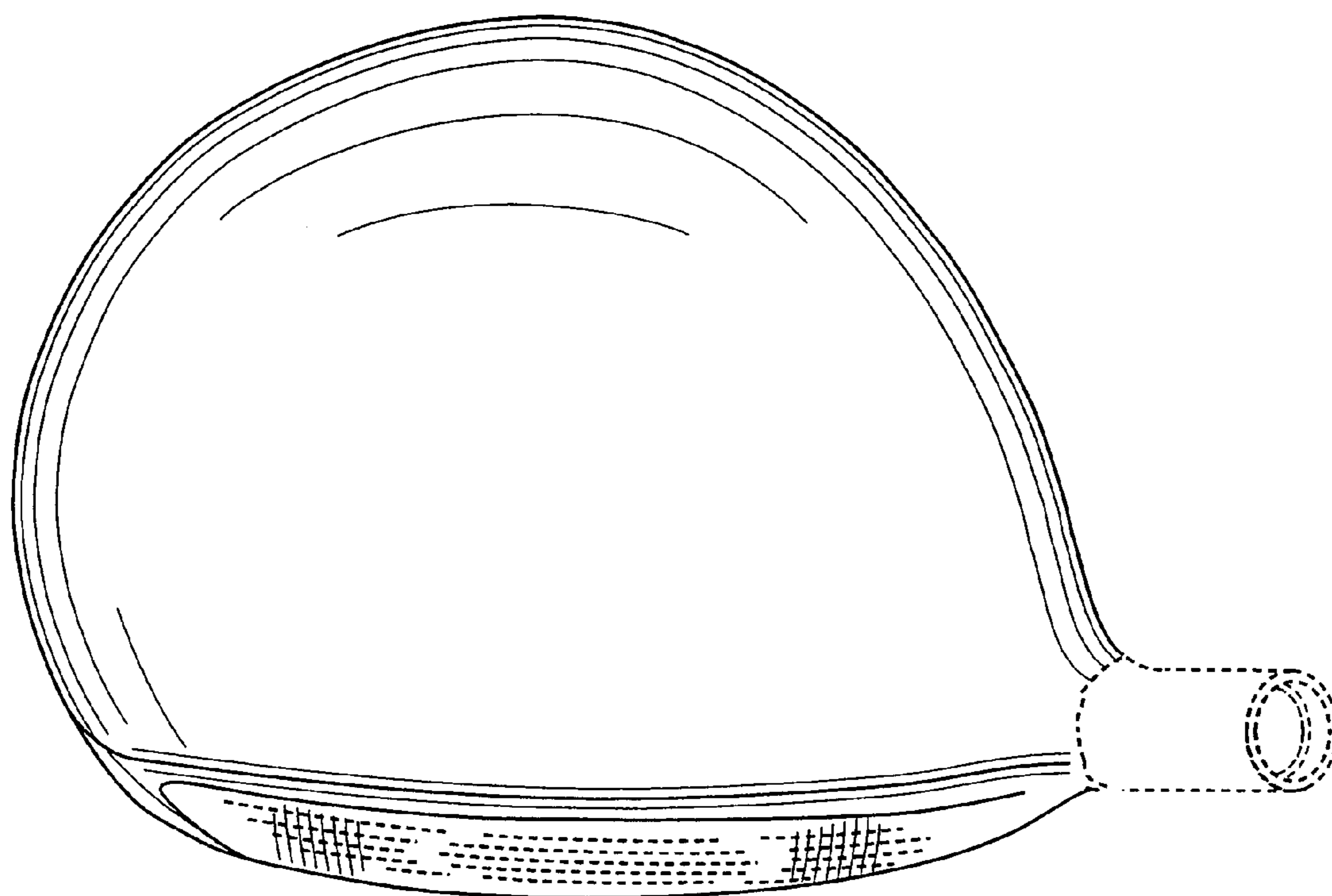

FIG. 6

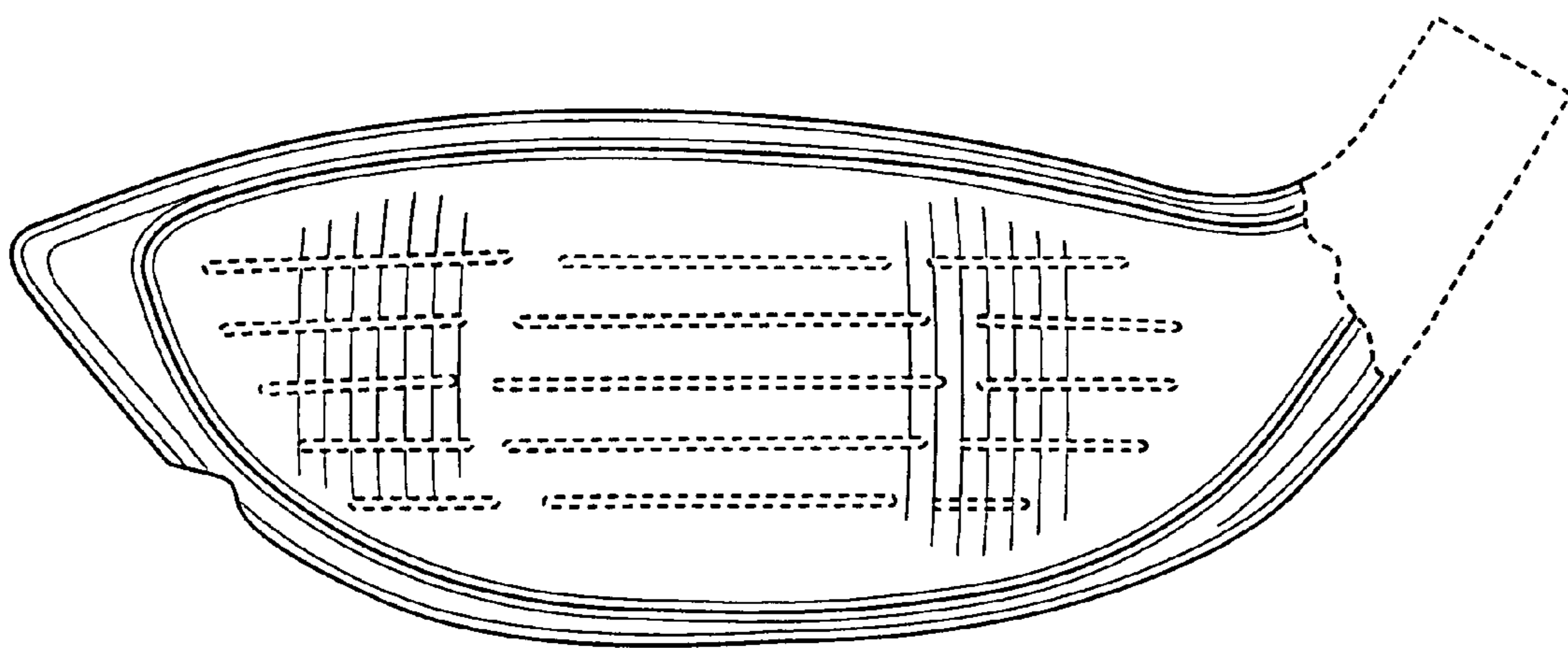

FIG. 7