



US00D558113S

(12) **United States Design Patent** (10) **Patent No.:** **US D558,113 S**
Leclercq (45) **Date of Patent:** **** Dec. 25, 2007**

(54) **SURFACE CONFIGURATION OF A DOOR FOR A VEHICLE**

(74) *Attorney, Agent, or Firm*—Crowell & Moring LLP

(75) **Inventor:** **Pierre Leclercq**, Munich (DE)

(57) **CLAIM**

(73) **Assignee:** **Bayerische Motoren Werke Aktiengesellschaft**, Munich (DE)

The ornamental design for a surface configuration of a door for a vehicle, as shown and described.

(**) **Term:** **14 Years**

DESCRIPTION

(21) **Appl. No.:** **29/270,228**

This application is related to the following co-pending application, of the inventor, filed on even date herewith:

(22) **Filed:** **Dec. 19, 2006**

Application Ser. No. 29/270,222, entitled “Surface Configuration of a Vehicle, Toy, and/or Other Replicas”.

(30) **Foreign Application Priority Data**

Jun. 20, 2006 (DE) 40603285

FIG. 1 is a left perspective view of a first embodiment of a surface configuration of a door for a vehicle according to my novel design;

(51) **LOC (8) Cl.** **12-16**

FIG. 2 is a right perspective view thereof;

(52) **U.S. Cl.** **D12/196**

FIG. 3 is a front view thereof;

(58) **Field of Classification Search** D12/196,

FIG. 4 is a right side view thereof; and

D12/86, 90–92; 296/181.1, 181.5

FIG. 5 is a left side view thereof.

See application file for complete search history.

FIG. 6 is a left perspective view of a second embodiment of the surface configuration of a door for a vehicle according to my novel design;

(56) **References Cited**

U.S. PATENT DOCUMENTS

D418,471 S *	1/2000	Gabath	D12/196
D467,849 S *	12/2002	Murkett	D12/196
D479,170 S *	9/2003	Boyer	D12/196
D491,859 S *	6/2004	Velazco	D12/196
D491,860 S *	6/2004	Velazco	D12/196
D511,128 S *	11/2005	Nagashima	D12/196
D511,129 S *	11/2005	Nagashima	D12/196

FIG. 7 is a right perspective view FIG. 6;

FIG. 8 is a front view FIG. 6;

FIG. 9 is a right side view FIG. 6; and,

FIG. 10 is a left side view FIG. 6.

The broken lines are for illustrative purposes only and form no part of the claimed design.

* cited by examiner

Primary Examiner—Melody N. Brown

1 Claim, 4 Drawing Sheets

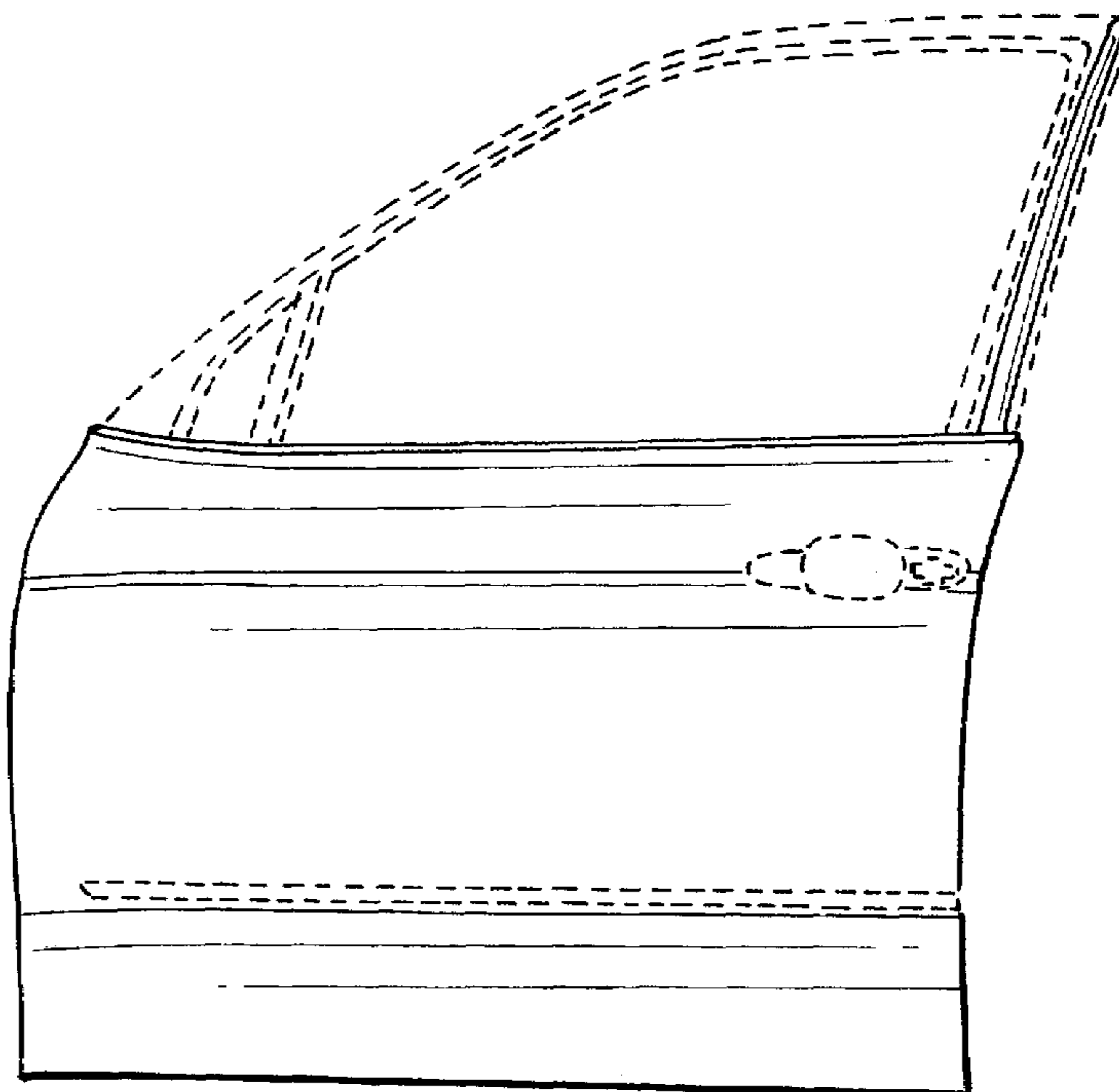

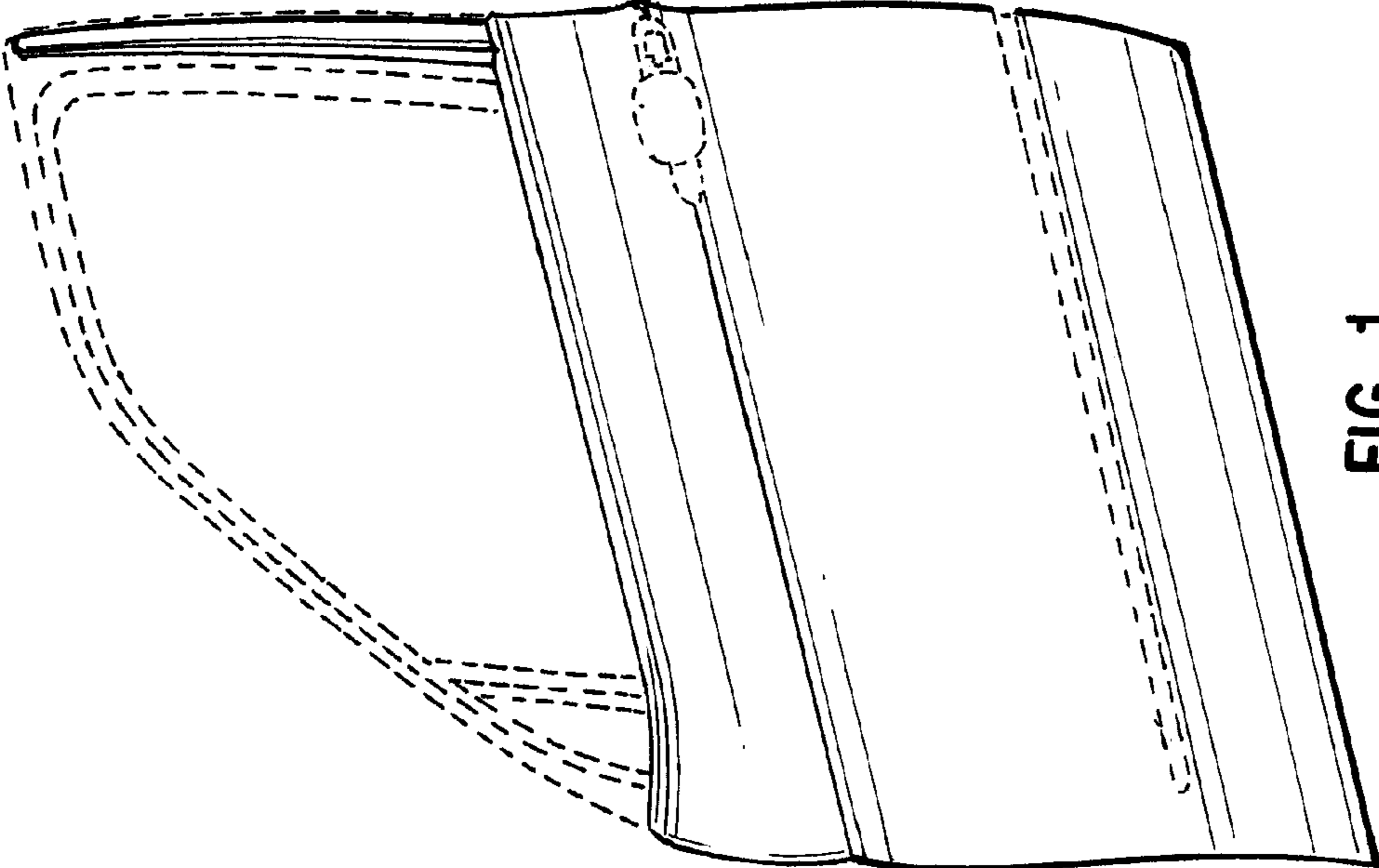

FIG. 1

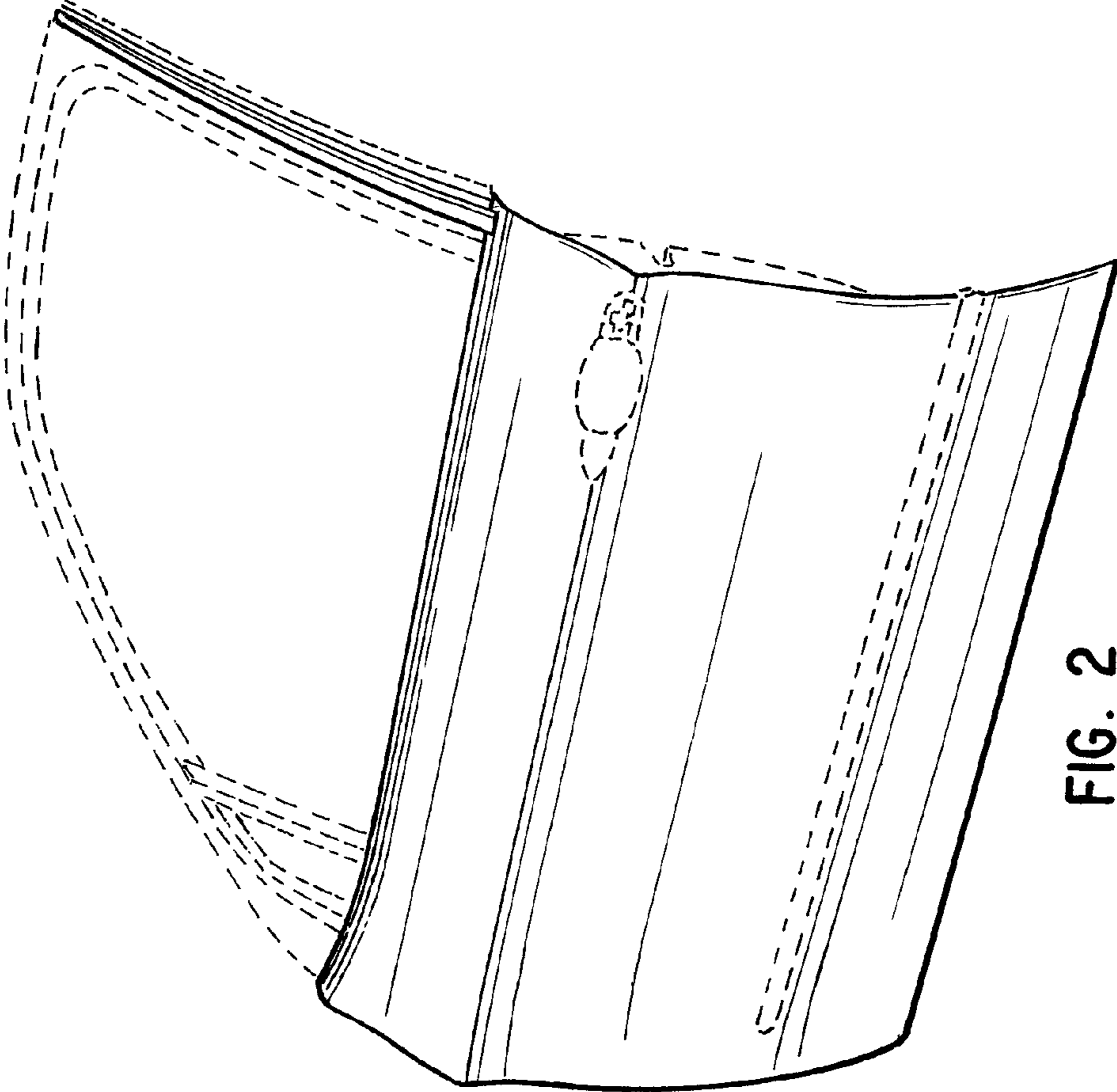
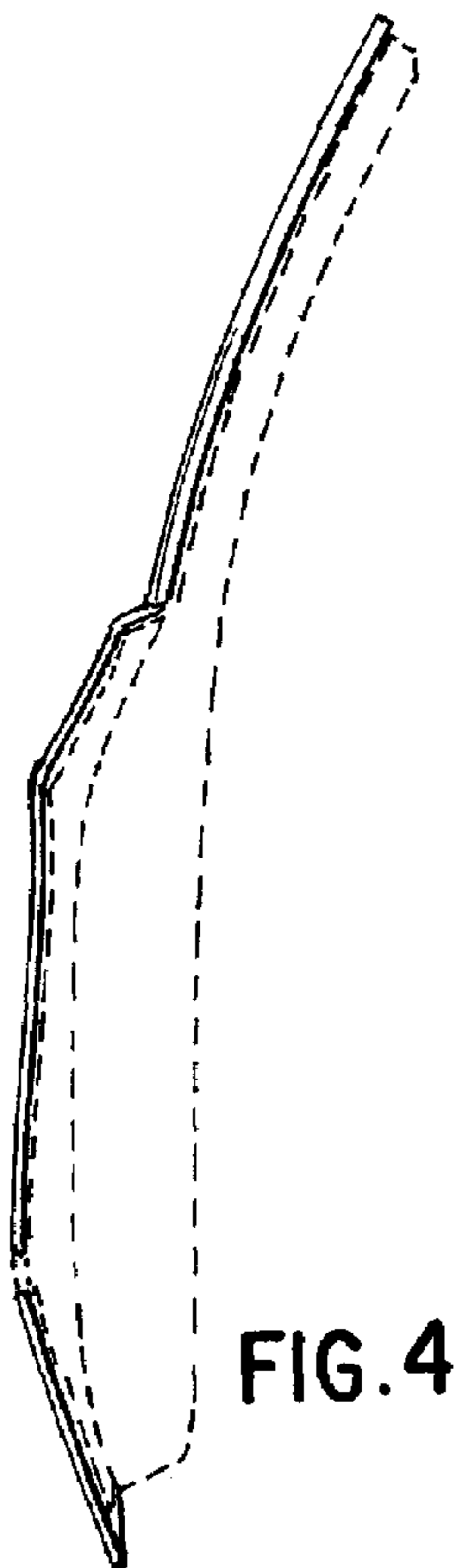
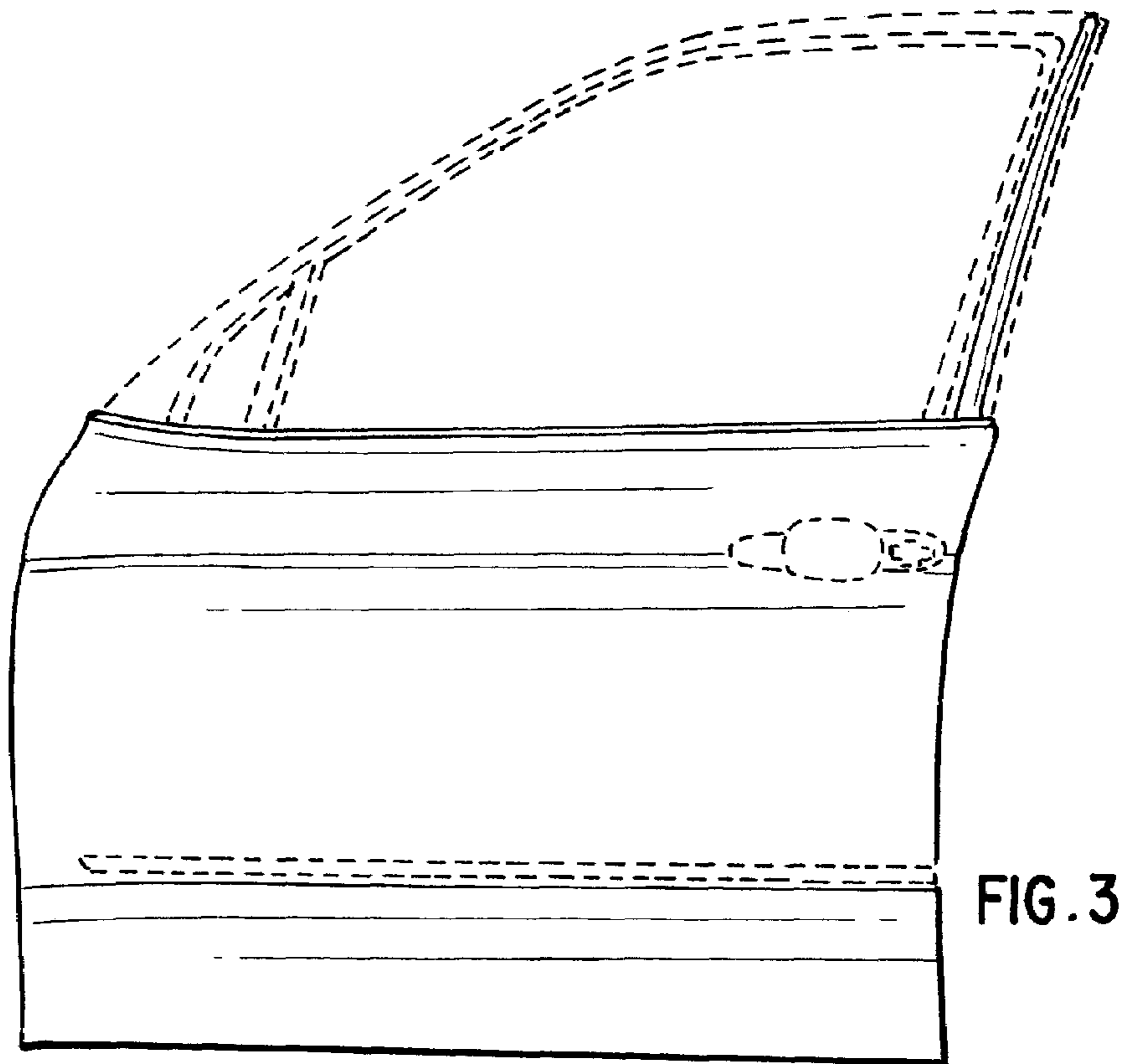

FIG. 2



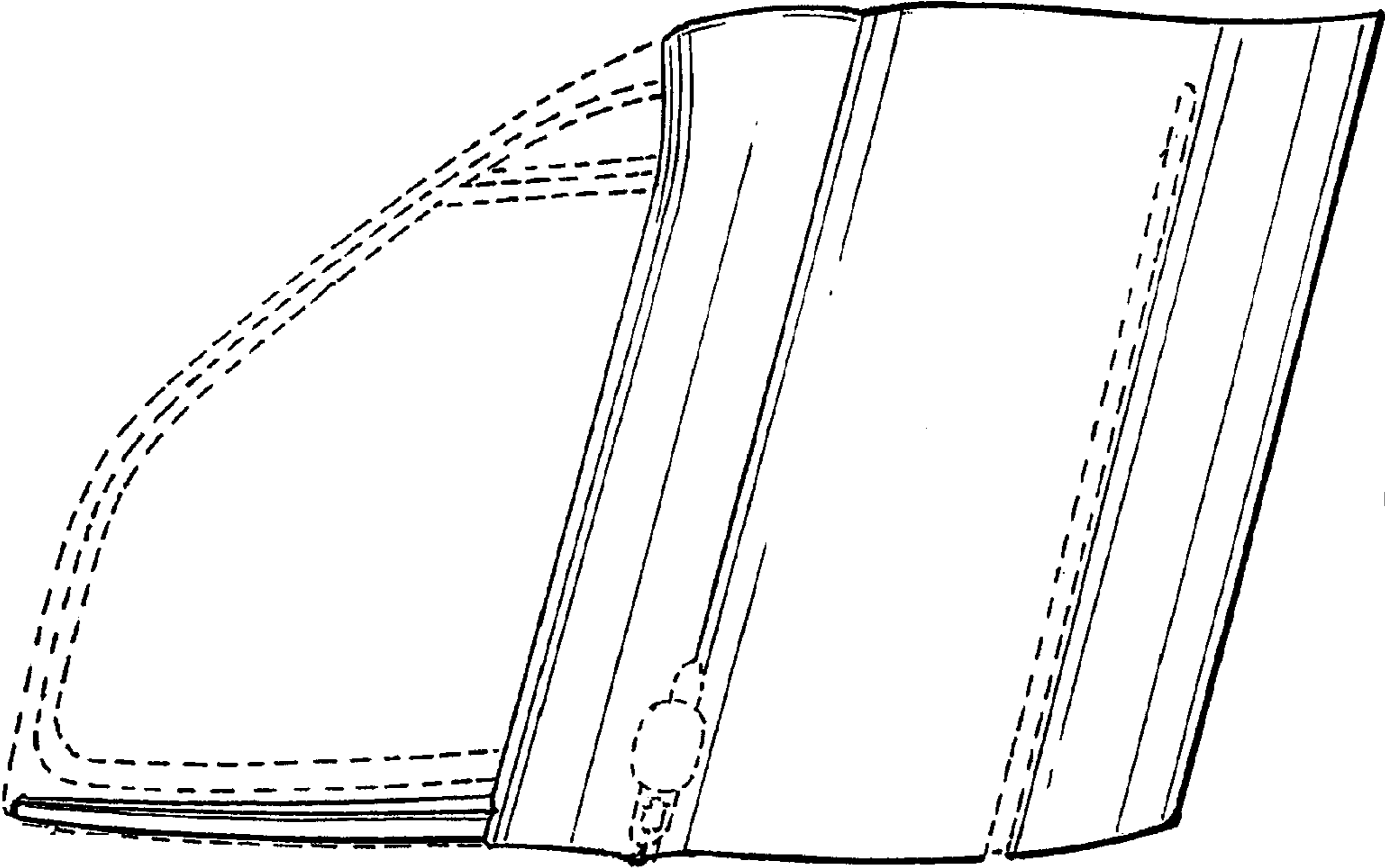

FIG. 7

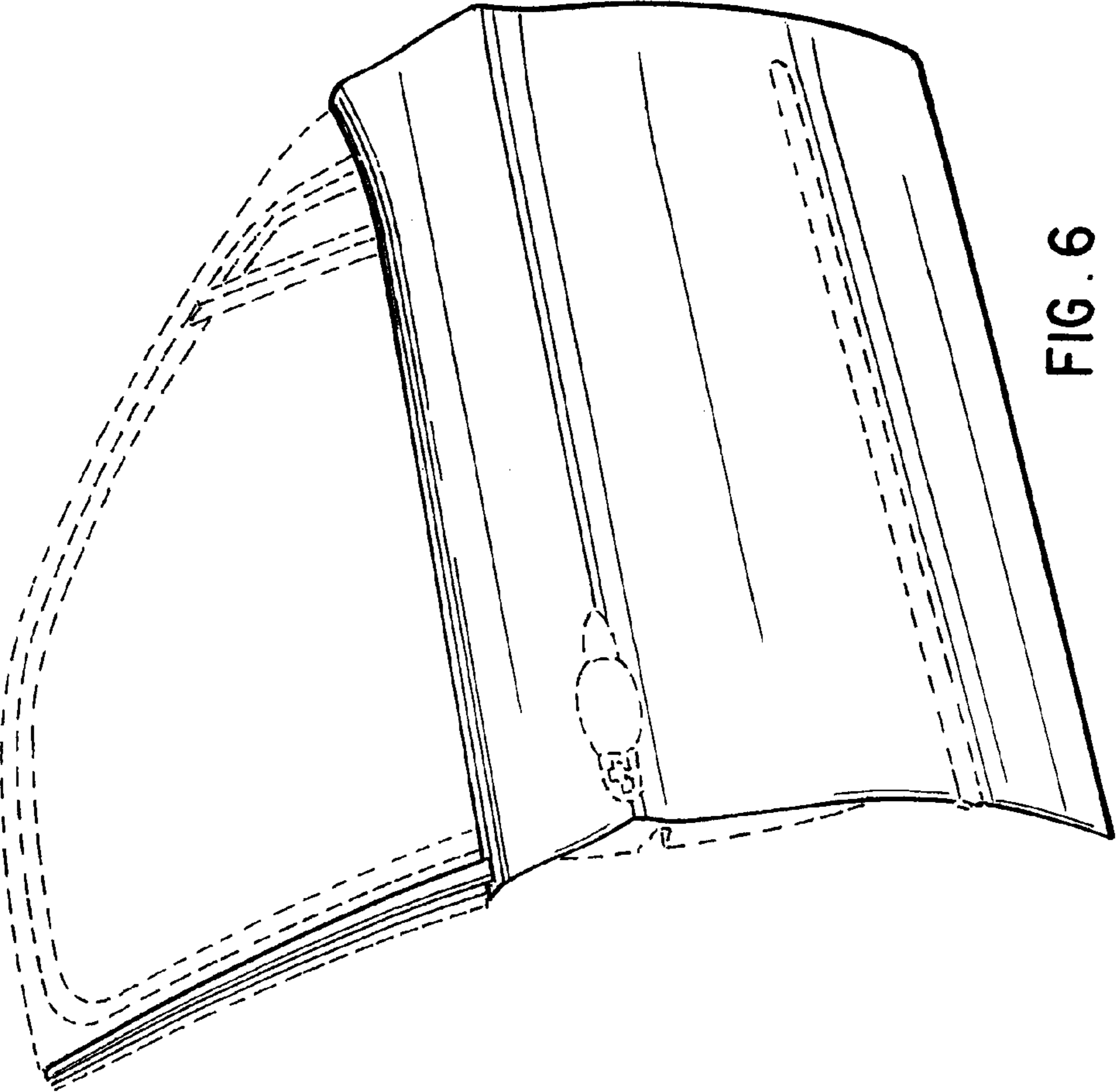

FIG. 6

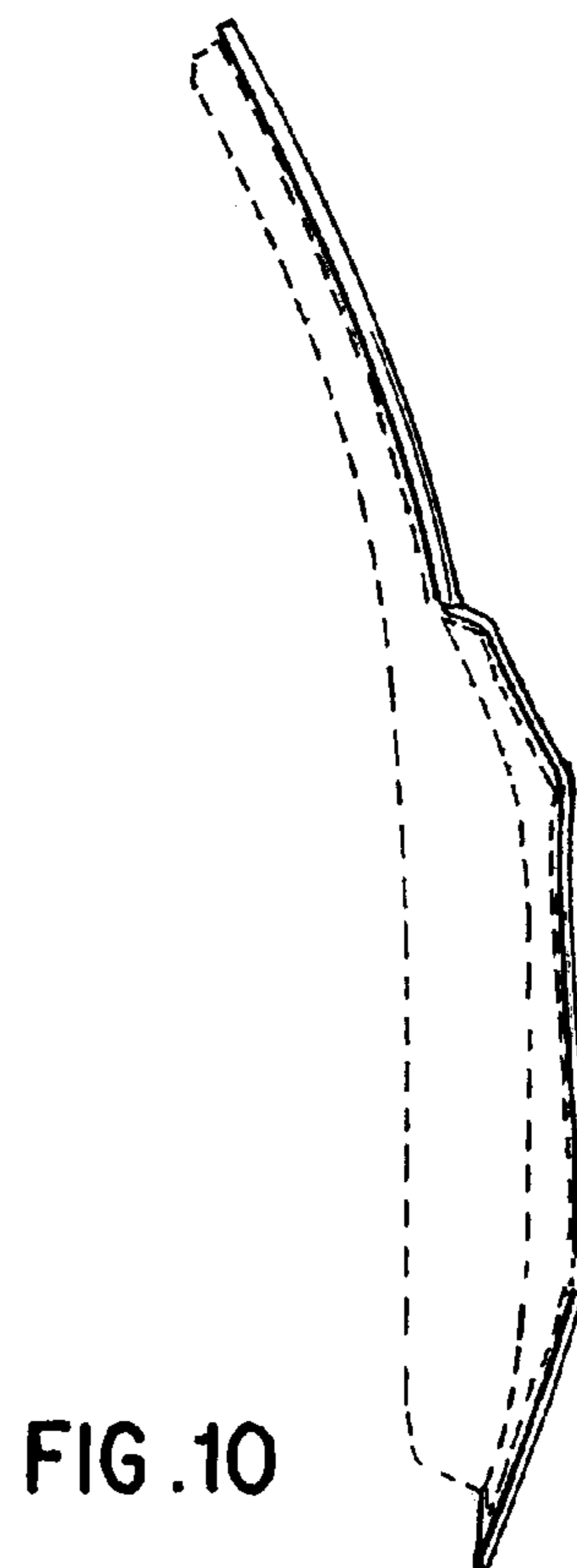
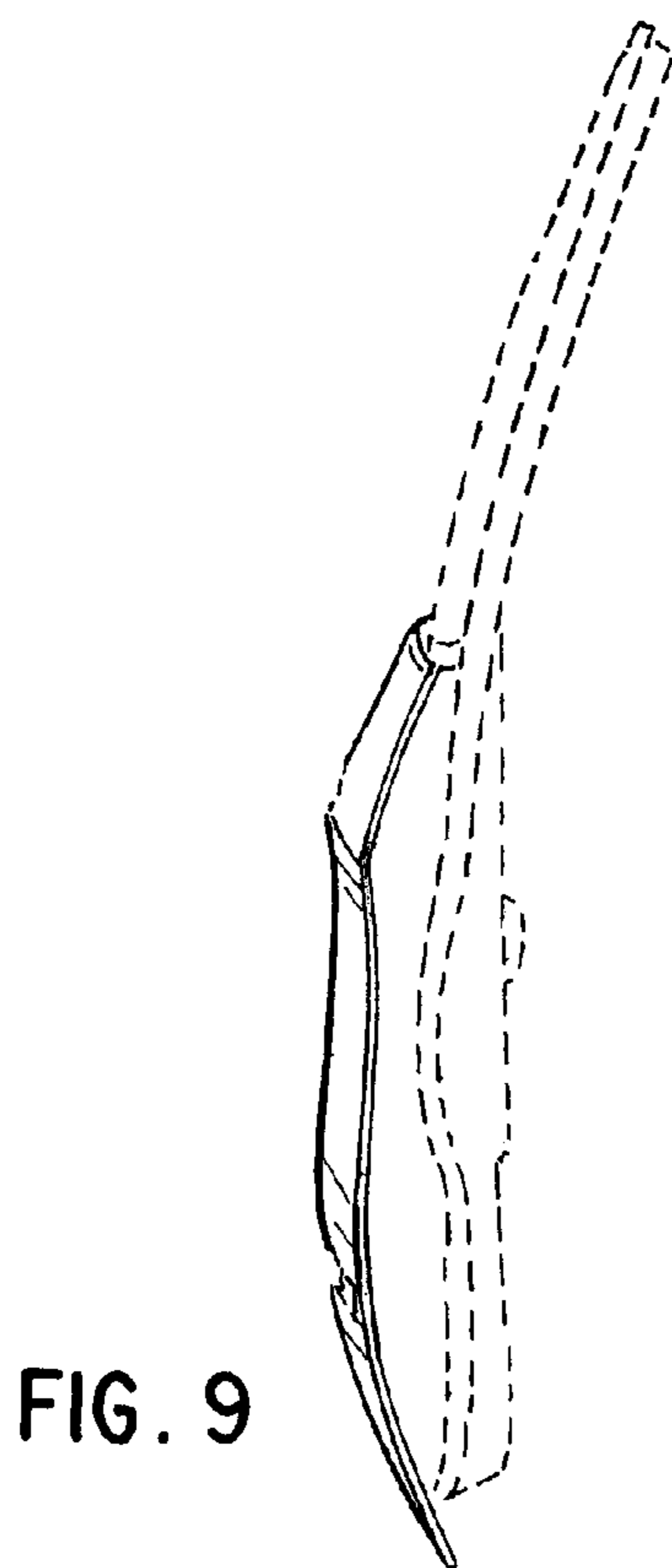
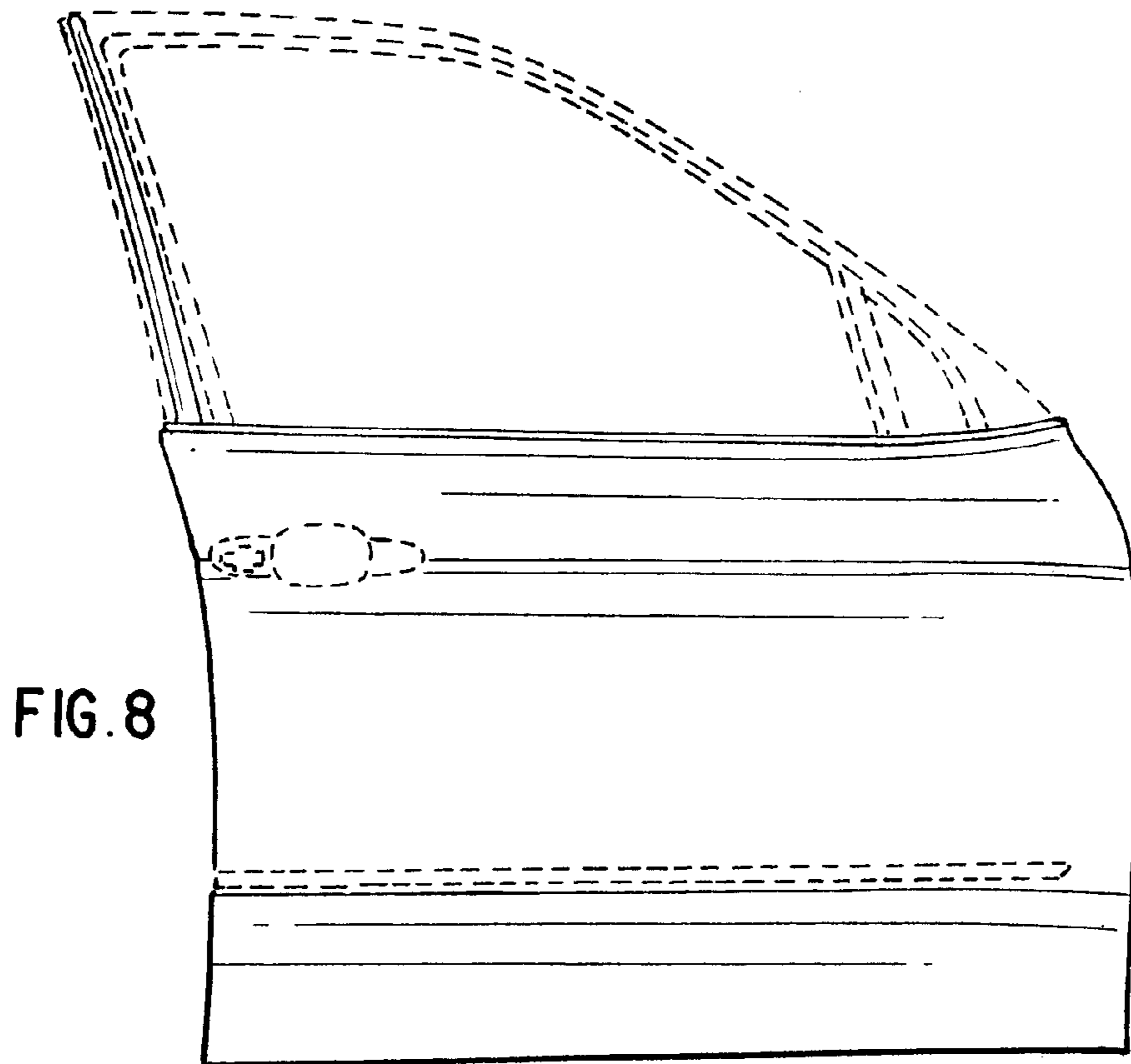

FIG. 9

FIG. 10