



US00D558107S

(12) **United States Design Patent**  
**Horner et al.**

(10) **Patent No.:** **US D558,107 S**

(45) **Date of Patent:** **\*\* Dec. 25, 2007**

(54) **HUB FOR A BRAKE BOOSTER**

(75) Inventors: **Charles Horner**, South Bend, IN (US);  
**Wayne Hewitt**, Laport, IN (US);  
**Joseph Whicker**, Elkhart, IN (US)

(73) Assignee: **Robert Bosch GmbH**, Stuttgart (DE)

(\*\*) Term: **14 Years**

(21) Appl. No.: **29/252,899**

(22) Filed: **Jan. 30, 2006**

(51) **LOC (8) Cl.** ..... **12-16**

(52) **U.S. Cl.** ..... **D12/180**

(58) **Field of Classification Search** ..... D12/180,  
D12/400; 91/369.2, 369.3, 376 R; 192/107 R,  
192/70.16; 188/24.11–24.13, 24.22, 73.2,  
188/209–211, 218 XL

See application file for complete search history.

(56) **References Cited**

**U.S. PATENT DOCUMENTS**

- D347,415 S \* 5/1994 Rossigno et al. .... D12/180
- D348,036 S \* 6/1994 Rossigno et al. .... D12/180
- 5,699,713 A \* 12/1997 Mortimer ..... 91/369.2
- 6,334,384 B1 \* 1/2002 Hoerner ..... 91/369.2

- D462,927 S \* 9/2002 Horner ..... D12/180
- 6,691,602 B1 \* 2/2004 Harth et al. .... 91/369.2
- 6,739,234 B2 \* 5/2004 Zinndorf et al. .... 91/369.2
- 6,931,979 B2 \* 8/2005 Bacardit et al. .... 91/369.2
- D512,945 S 12/2005 Hewitt et al. .... D12/180

\* cited by examiner

*Primary Examiner*—Stacia Cadmus

(74) *Attorney, Agent, or Firm*—Leo H. McCormick, Jr.;  
Sarah Taylor

(57) **CLAIM**

The ornamental design of a hub for a brake booster, as shown and described.

**DESCRIPTION**

FIG. 1 is a front perspective view of a hub for a brake booster showing our new design;

FIG. 2 is a rear perspective view of the hub for a brake booster of FIG. 1;

FIG. 3 is a top view of FIG. 1;

FIG. 4 is a bottom view of FIG. 1;

FIG. 5 is a front elevation view of FIG. 3; and,

FIG. 6 is a rear elevation of FIG. 3.

**1 Claim, 3 Drawing Sheets**

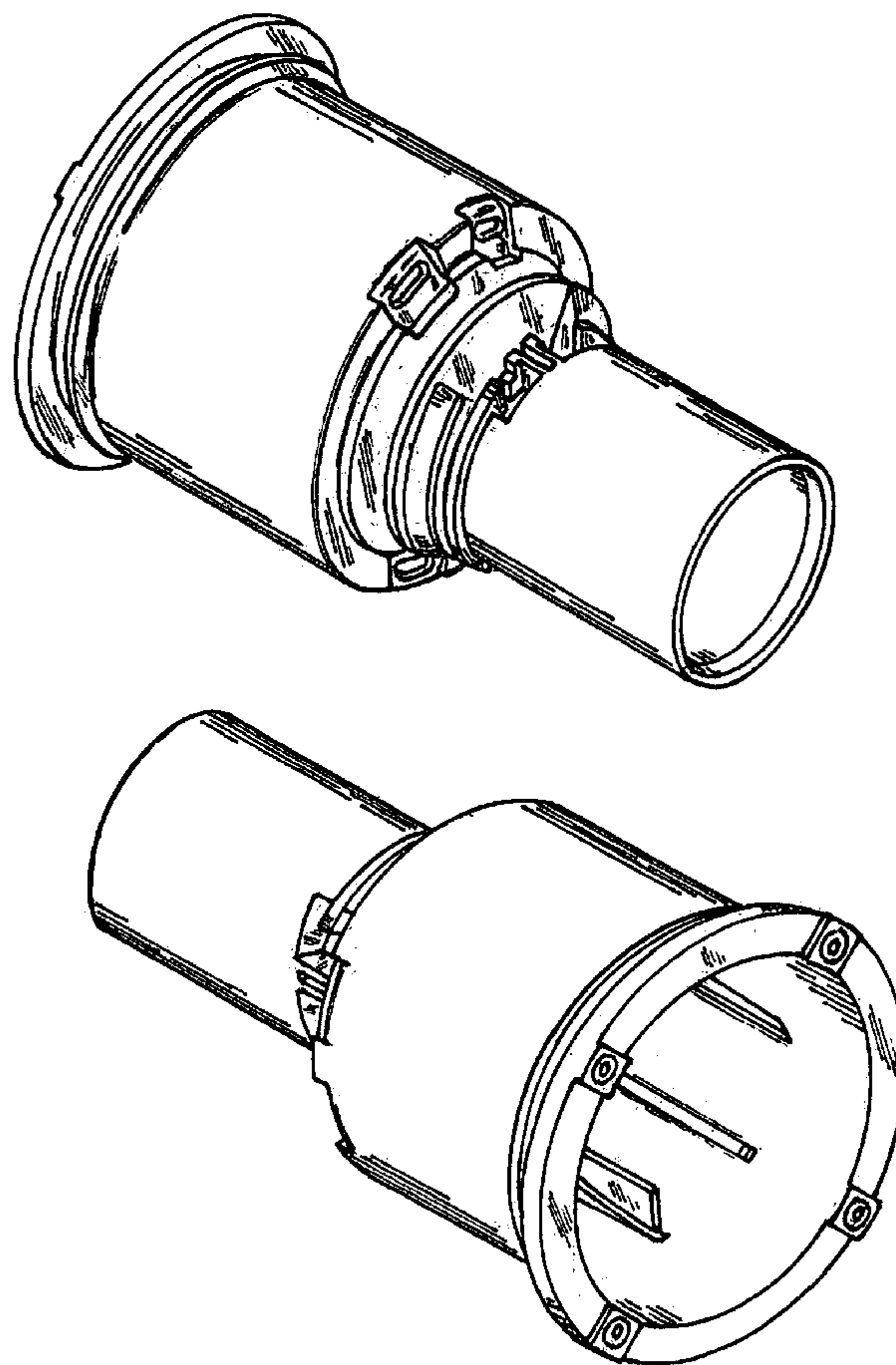

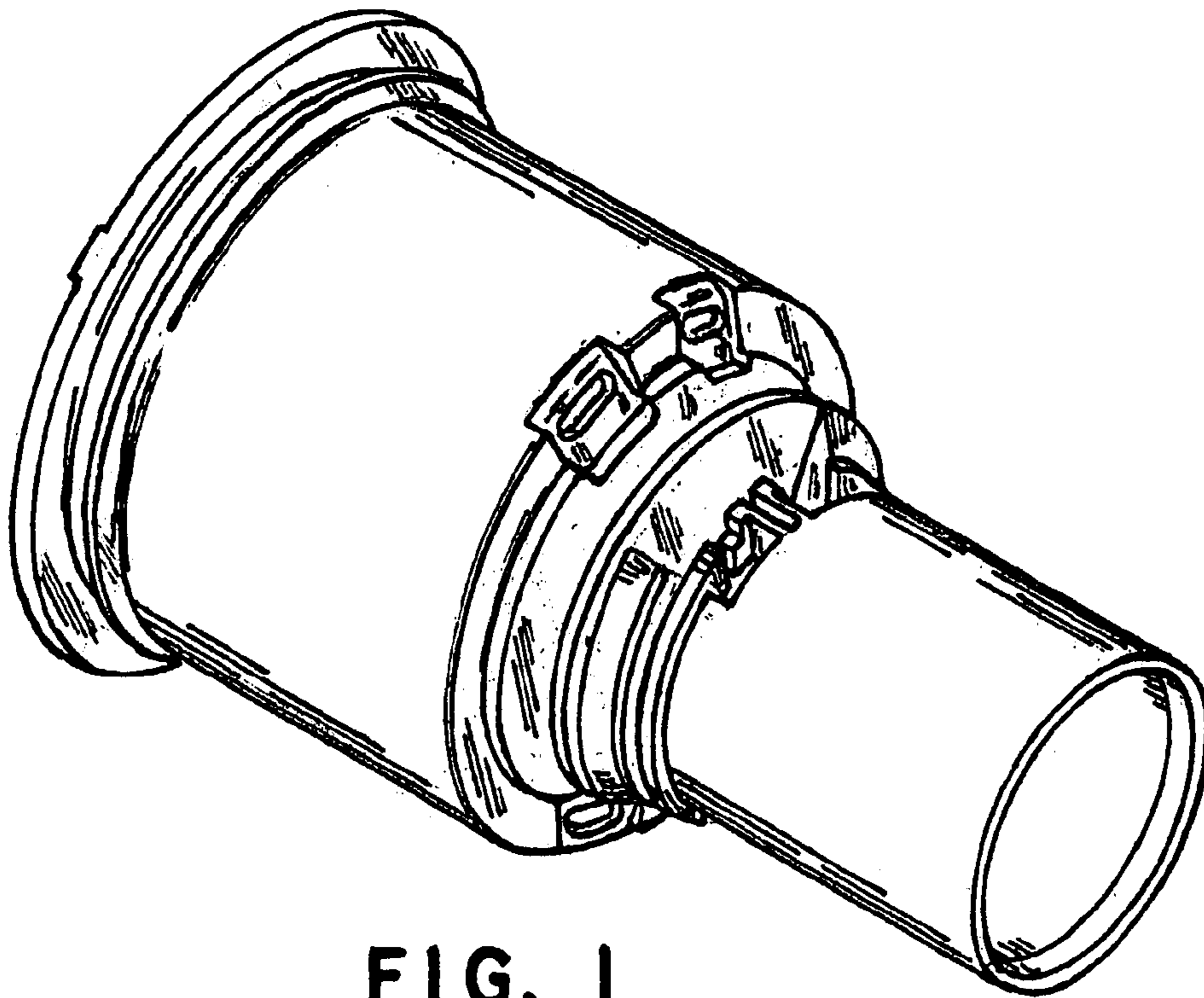

FIG. 1

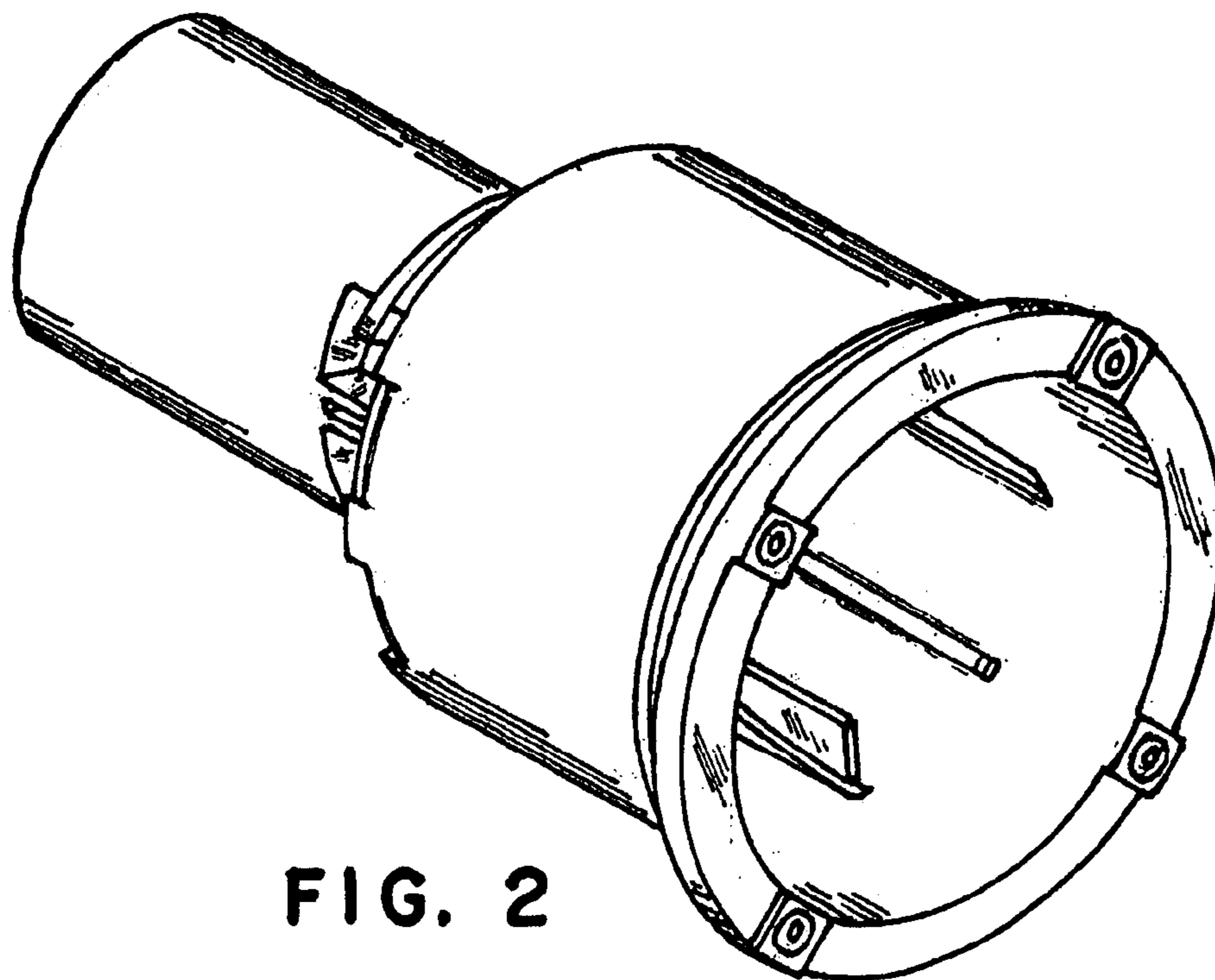

FIG. 2

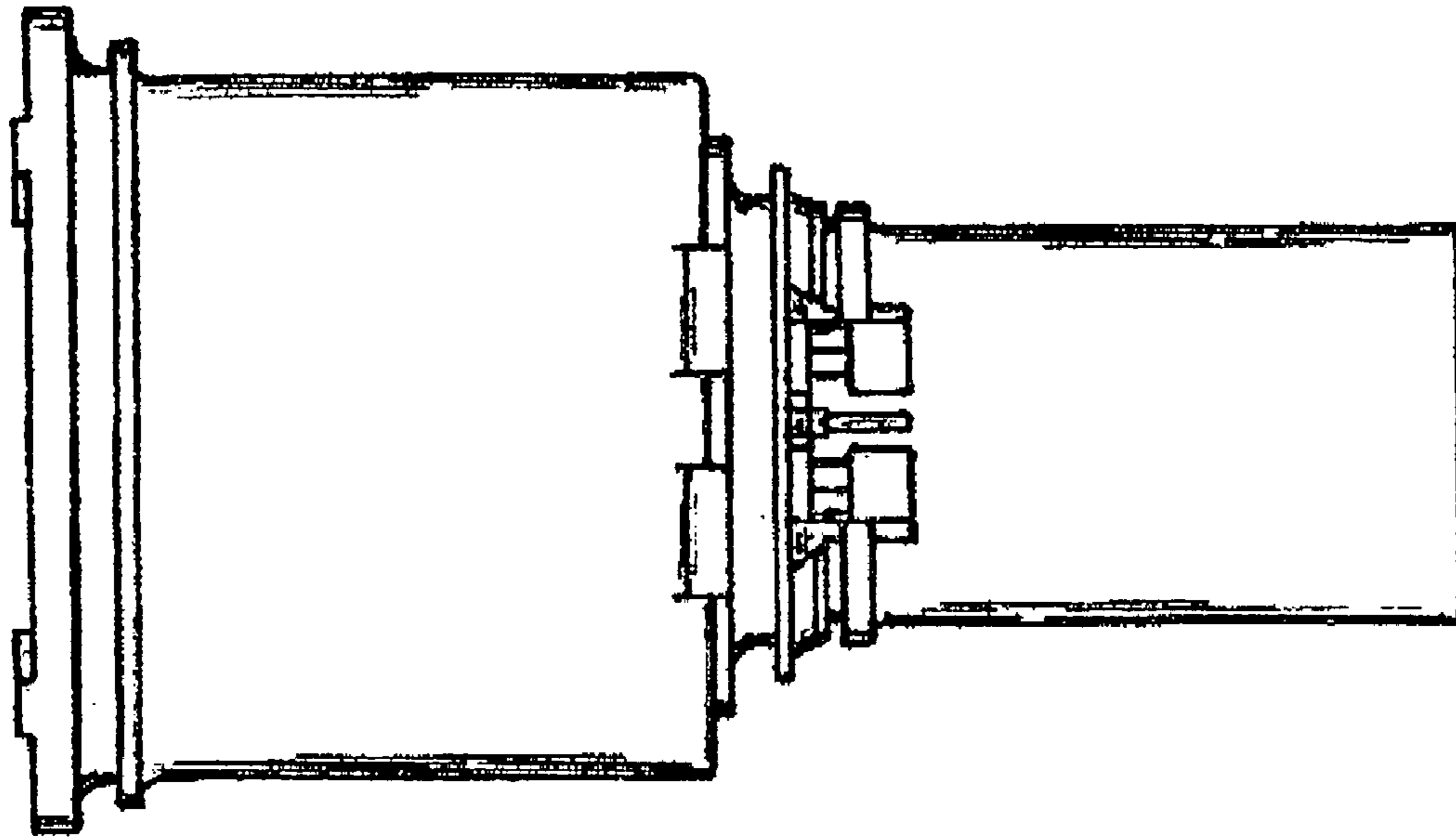

FIG. 3

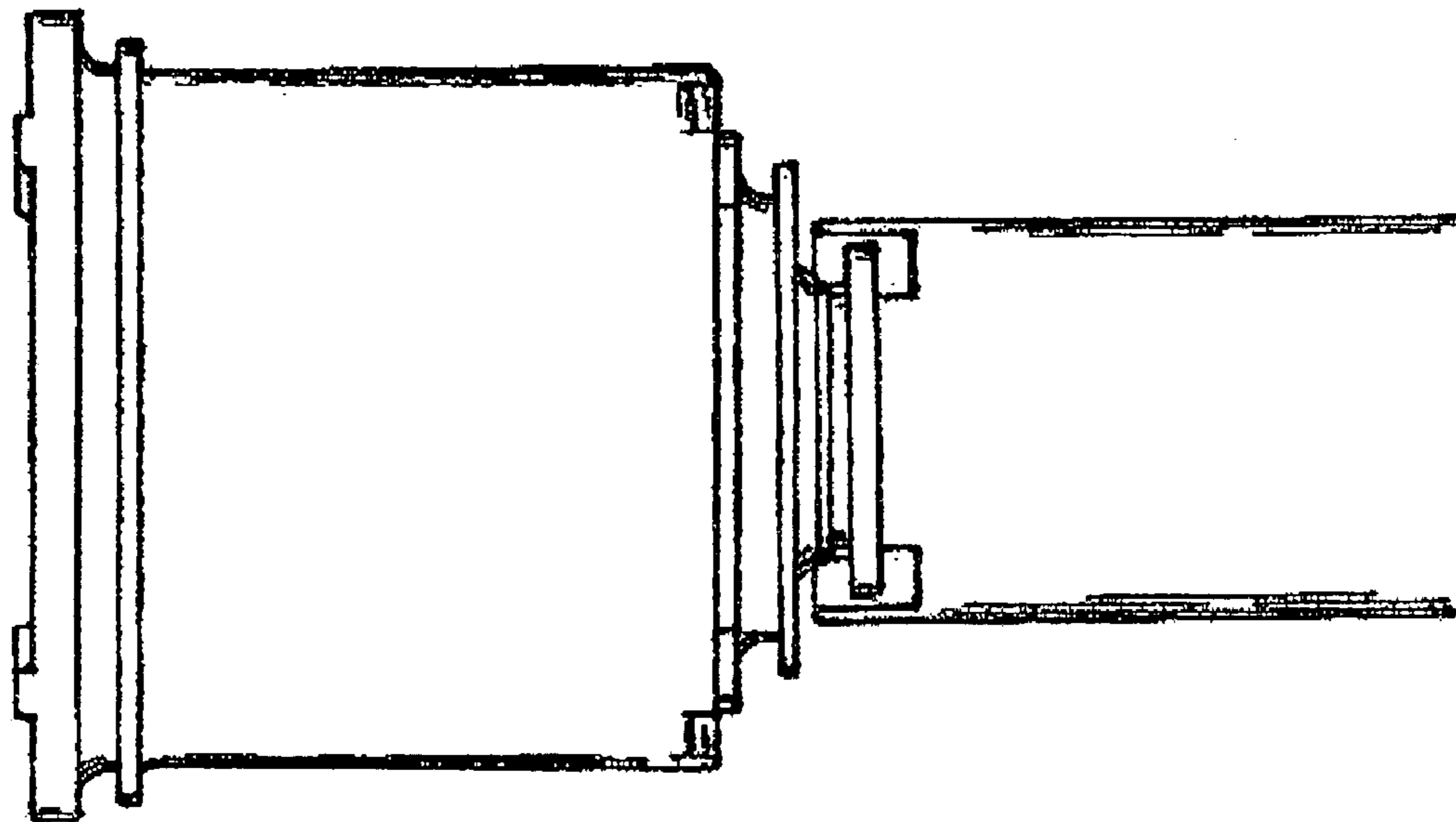
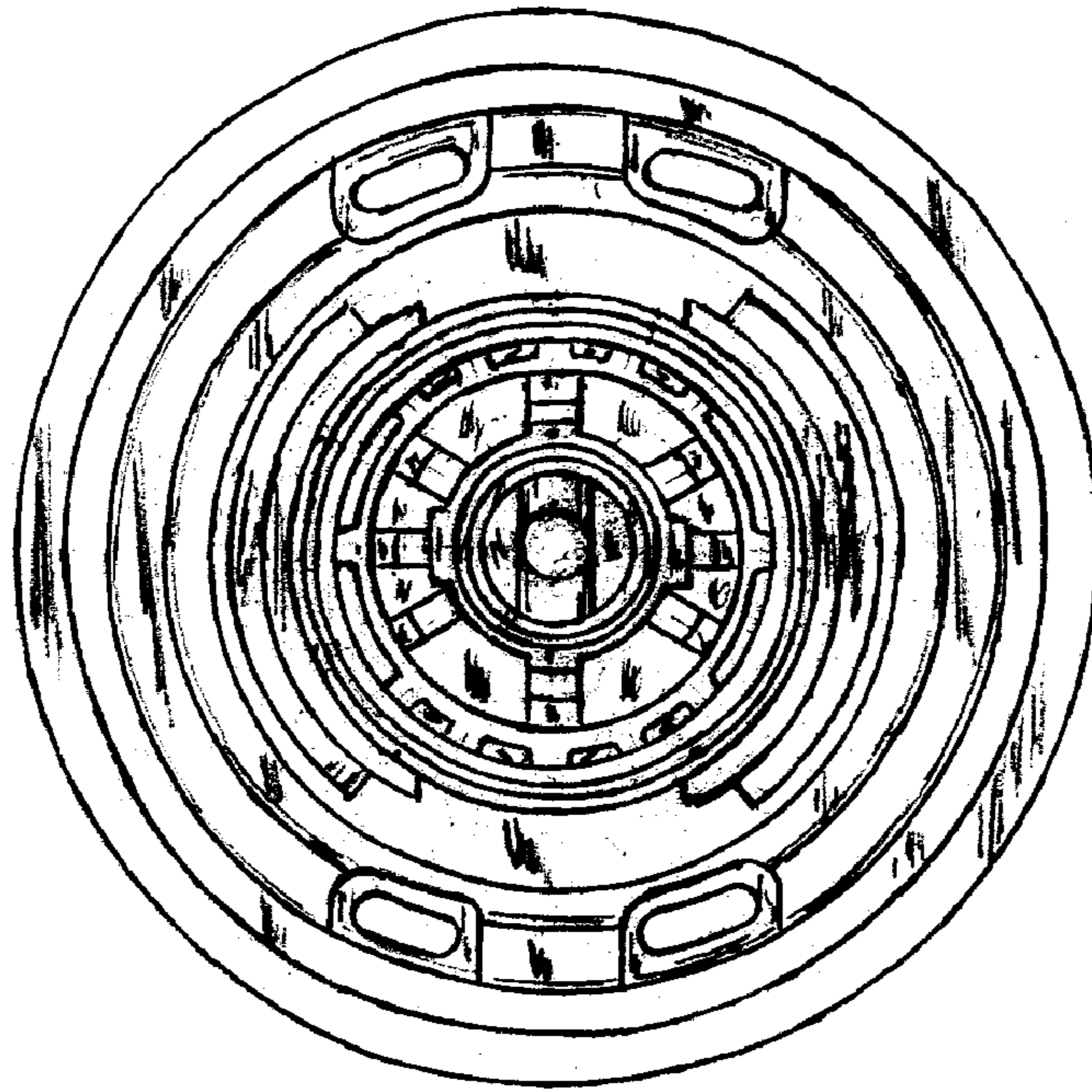
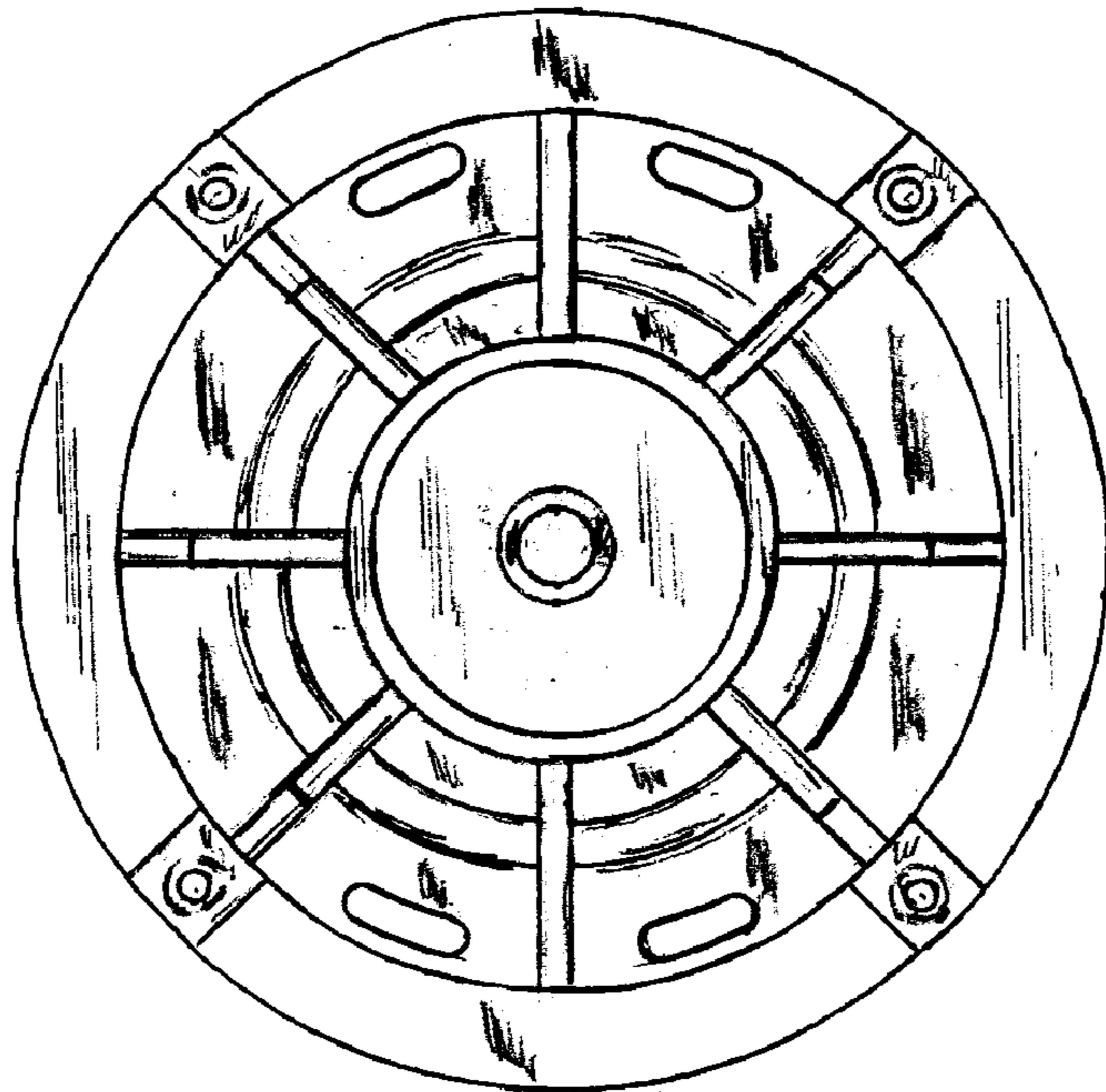

FIG. 4



*Fig. 5*



*Fig. 6*