



US00D557180S

(12) **United States Design Patent**
Thiers et al.

(10) **Patent No.:** **US D557,180 S**
(45) **Date of Patent:** **** Dec. 11, 2007**

(54) **SADDLE BAG GUARD FOR A MOTORCYCLE**

(75) Inventors: **Jean-Michel Thiers**, Cypress, CA (US);
Mark Blankers, Cypress, CA (US)

(73) Assignee: **Yamaha Motor Corporation, U.S.A.**,
Cypress, CA (US)

(**) Term: **14 Years**

(21) Appl. No.: **29/261,392**

(22) Filed: **Jun. 12, 2006**

(51) **LOC (8) Cl.** **12-11**

(52) **U.S. Cl.** **D12/126**

(58) **Field of Classification Search** D12/110,
D12/126, 409, 410, 222, 223, 190; 180/219;
296/37.1; 280/288.4, 304.3, 770; 224/412-435,
224/441, 442, 42.11, 447-449, 457
See application file for complete search history.

(56) **References Cited**

U.S. PATENT DOCUMENTS

D459,275 S *	6/2002	Price	D12/114
6,419,039 B1 *	7/2002	Wagner	180/219
6,837,509 B2 *	1/2005	Welch et al.	280/304.3
7,025,368 B2 *	4/2006	Barnes	280/291

* cited by examiner

Primary Examiner—Cathron C. Brooks

Assistant Examiner—Linda Brooks

(74) *Attorney, Agent, or Firm*—Knobbe Martens Olson &
Bear LLP

(57) **CLAIM**

The ornamental design for a saddle bag guard for a motorcycle, as shown and described.

DESCRIPTION

FIG. 1 is a front perspective view of a saddle bag guard for a motorcycle configured in accordance with a first embodi-

ment of the present invention, for placement on a left side saddle bag;

FIG. 2 is a front plan view of the saddle bag guard for a motorcycle of FIG. 1;

FIG. 3 is a rear plan view of the saddle bag guard for a motorcycle of FIG. 1;

FIG. 4 is a top view of the saddle bag guard for a motorcycle of FIG. 1;

FIG. 5 is a bottom view of the saddle bag guard for a motorcycle of FIG. 1;

FIG. 6 is a left side view of the saddle bag guard for a motorcycle of FIG. 1;

FIG. 7 is a right side view of the saddle bag guard for a motorcycle of FIG. 1;

FIG. 8 is a front perspective view of a saddle bag guard for a motorcycle configured in accordance with a second embodiment of the present invention, for placement on a right side saddle bag;

FIG. 9 is a front plan view of the saddle bag guard for a motorcycle of FIG. 8;

FIG. 10 is a rear plan view of the saddle bag guard for a motorcycle of FIG. 8;

FIG. 11 is a top view of the saddle bag guard for a motorcycle of FIG. 8;

FIG. 12 is a bottom view of the saddle bag guard for a motorcycle of FIG. 8;

FIG. 13 is a left side view of the saddle bag guard for a motorcycle of FIG. 8; and,

FIG. 14 is a right side view of the saddle bag guard for a motorcycle of FIG. 8.

1 Claim, 8 Drawing Sheets

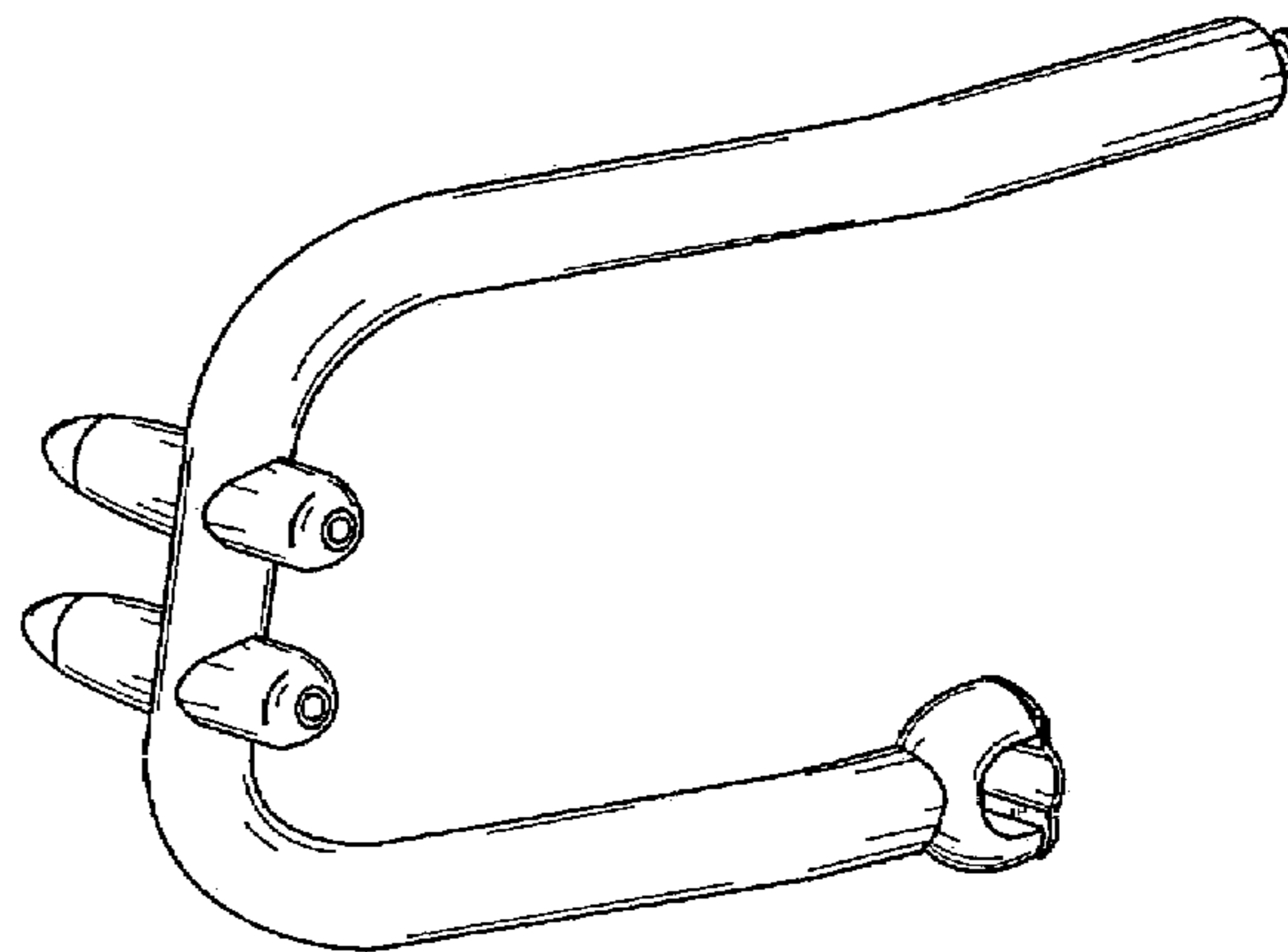
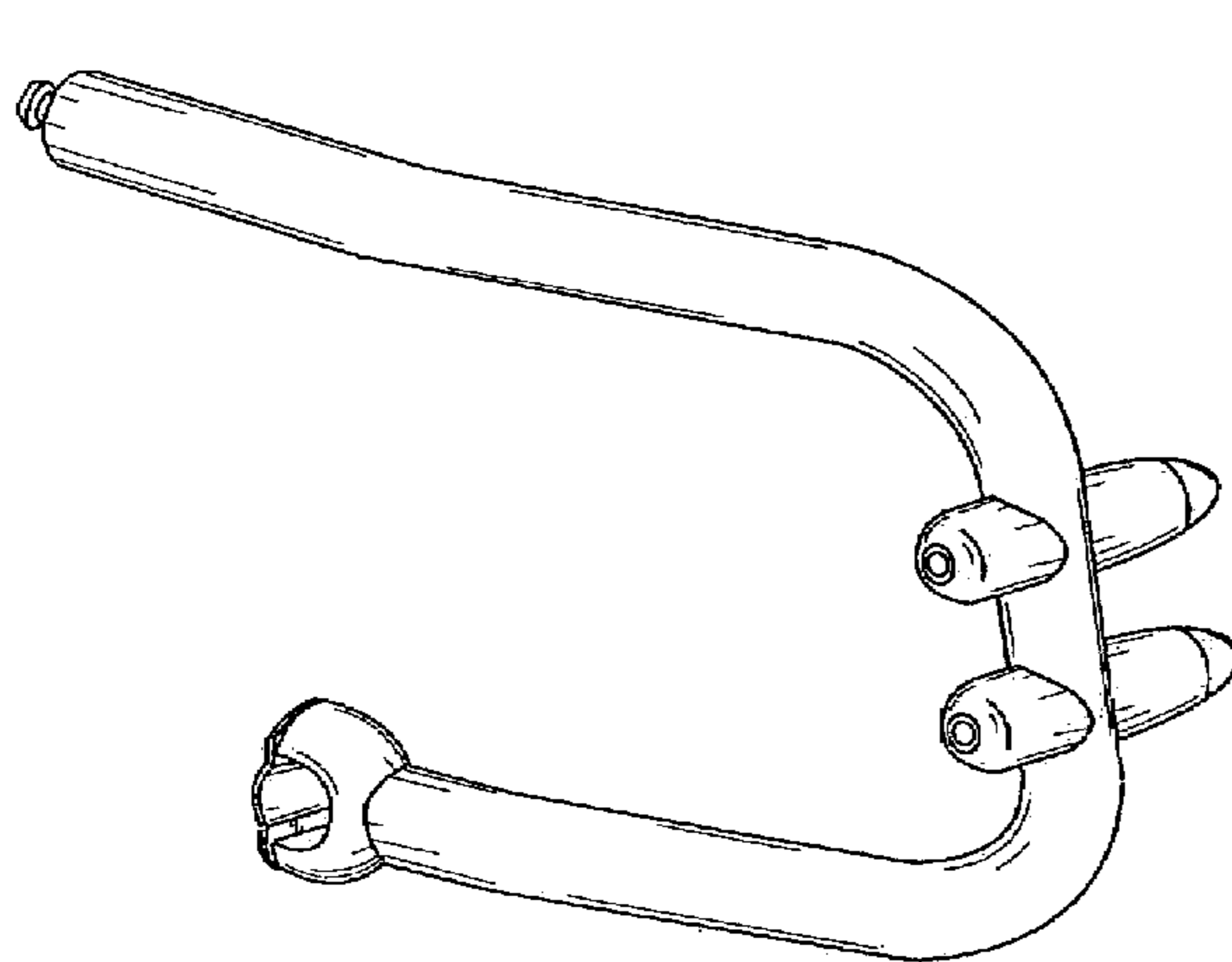

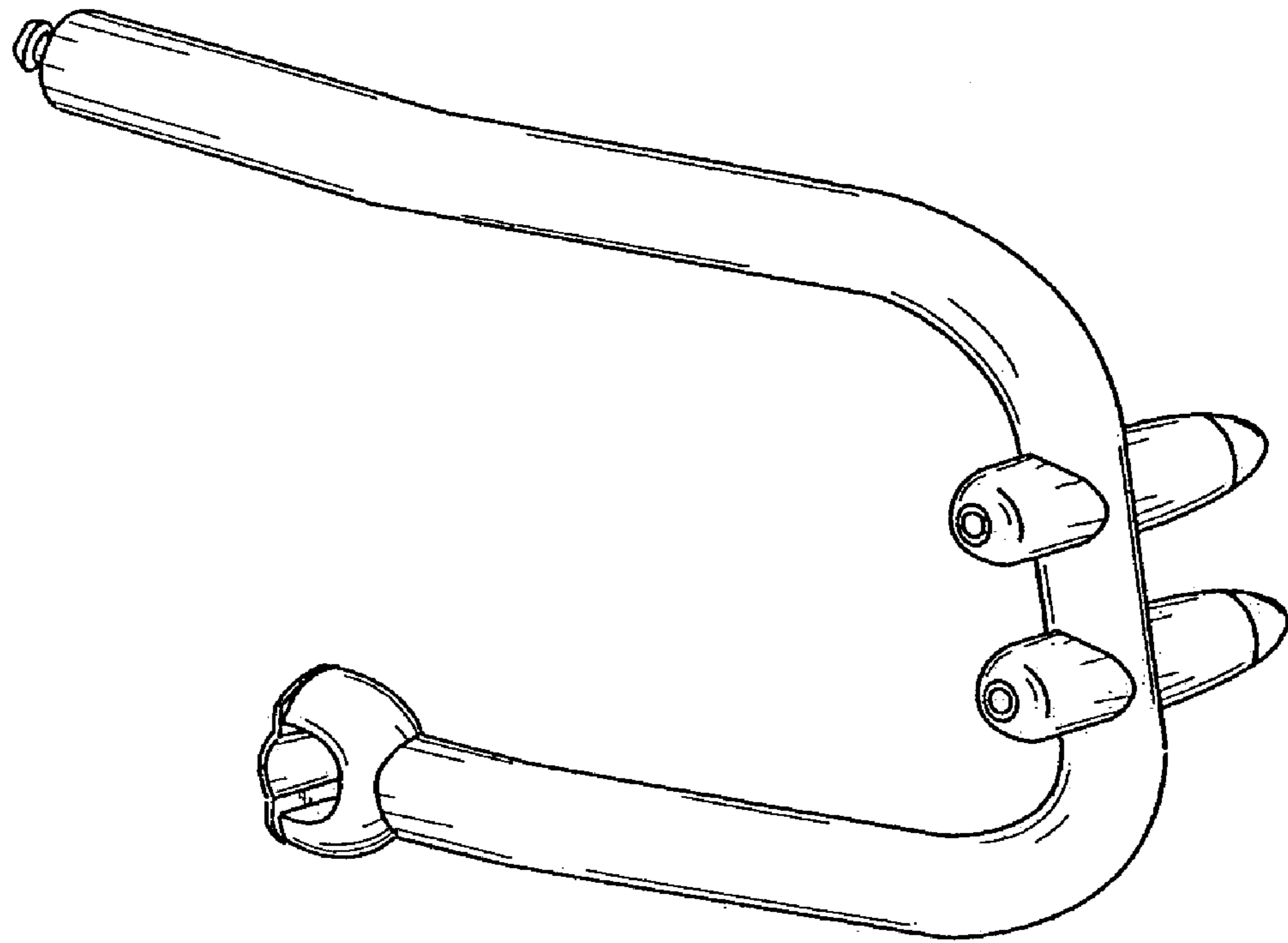

Figure 1

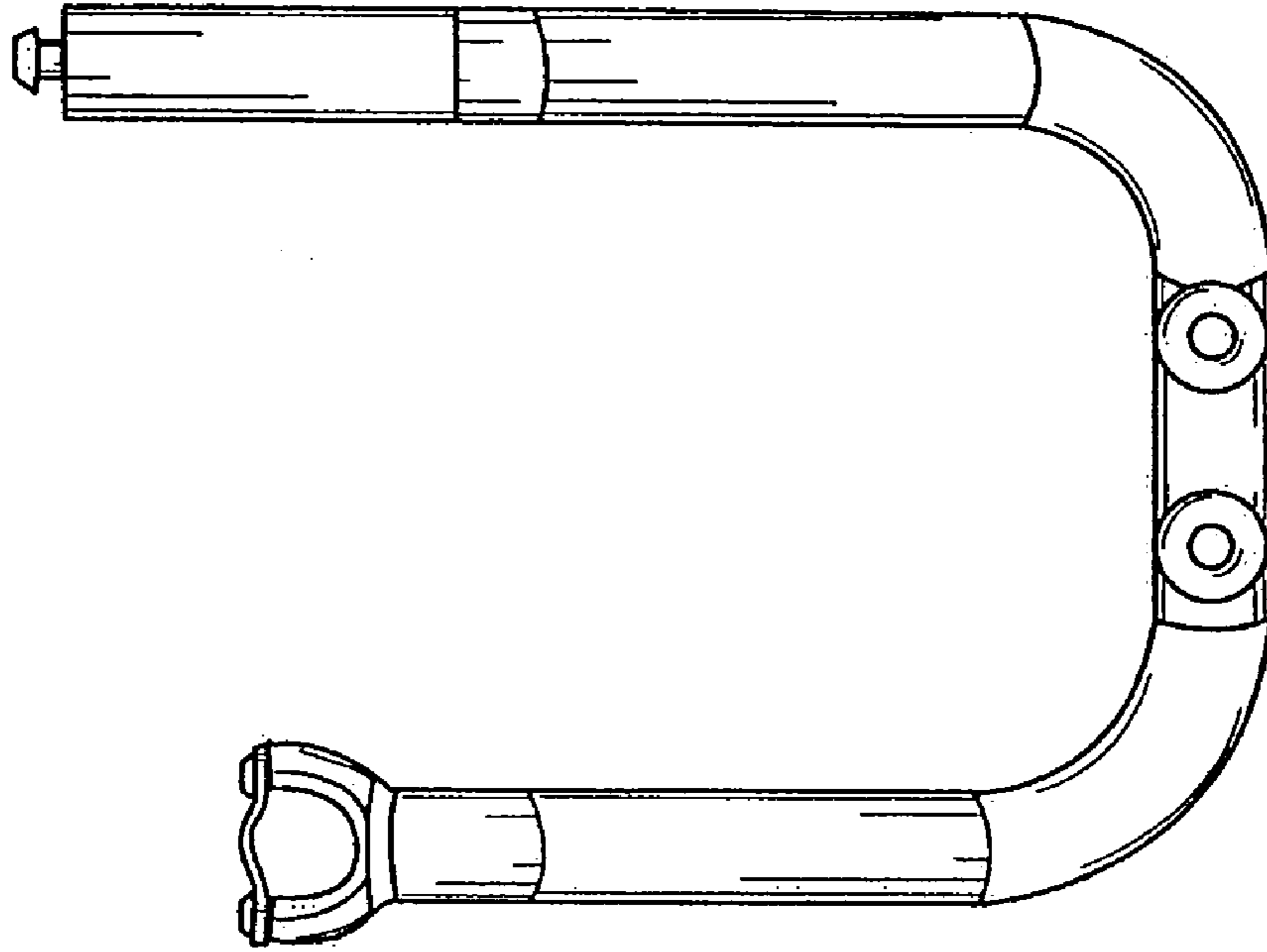

Figure 2

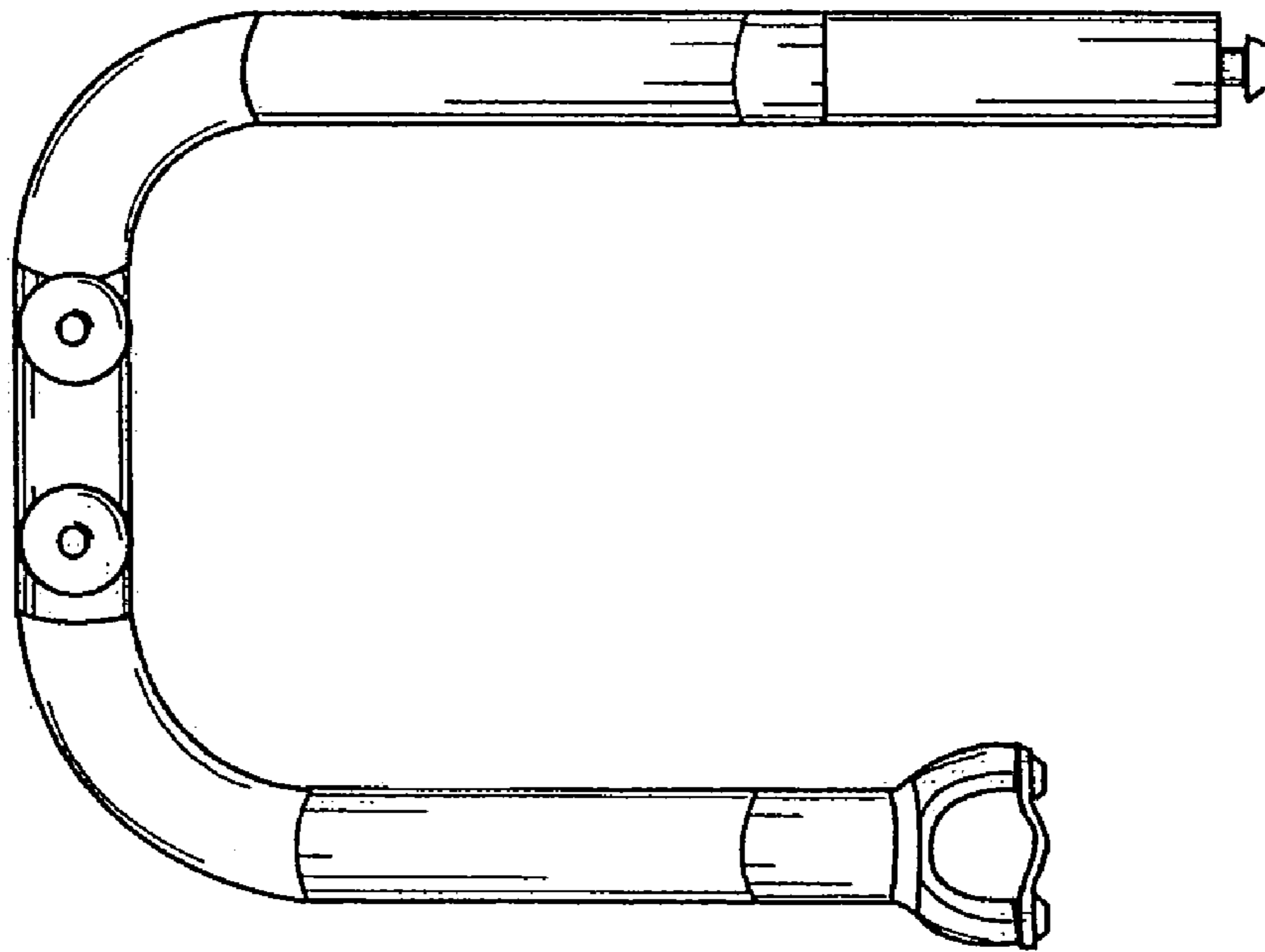

Figure 3

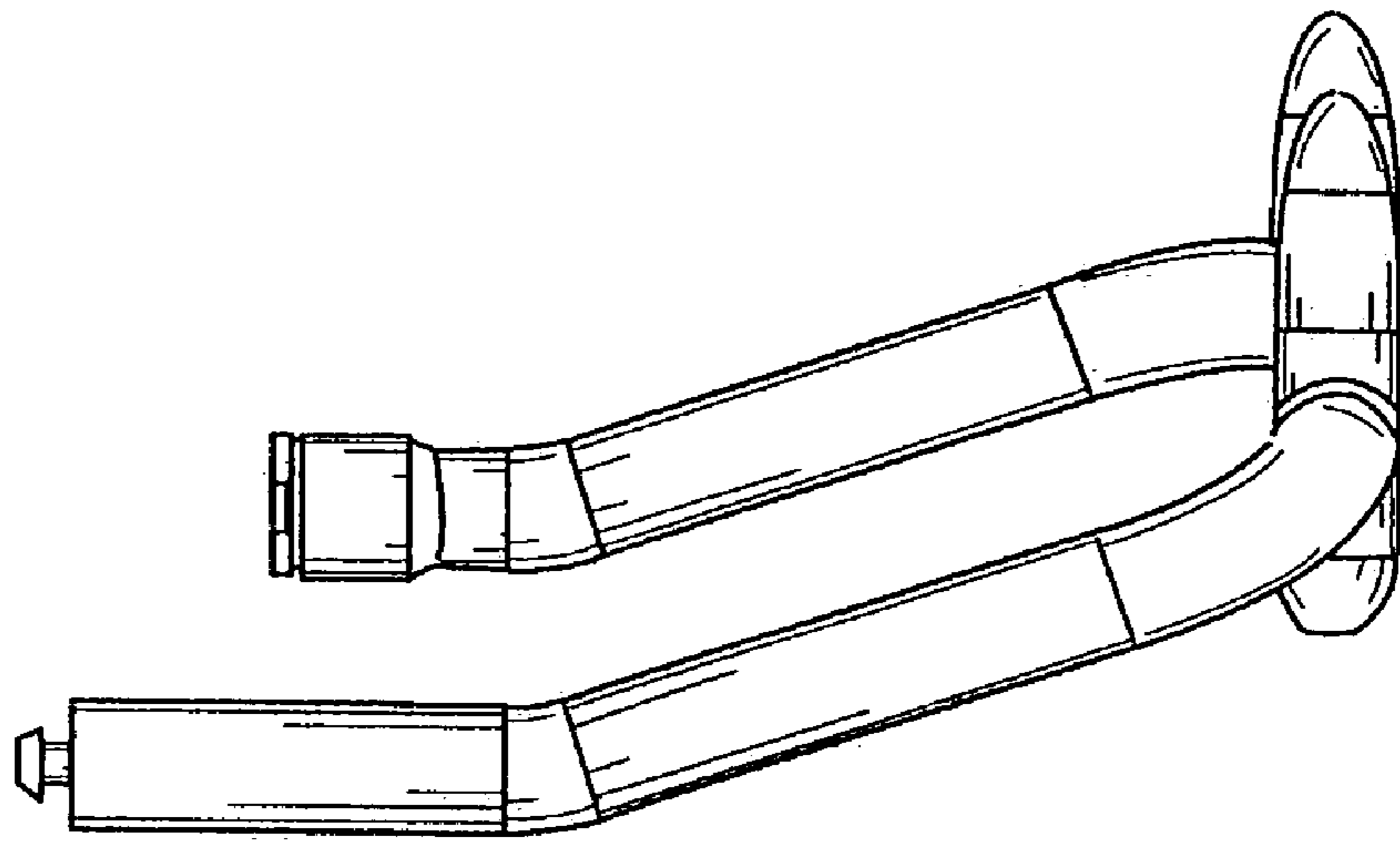

Figure 4

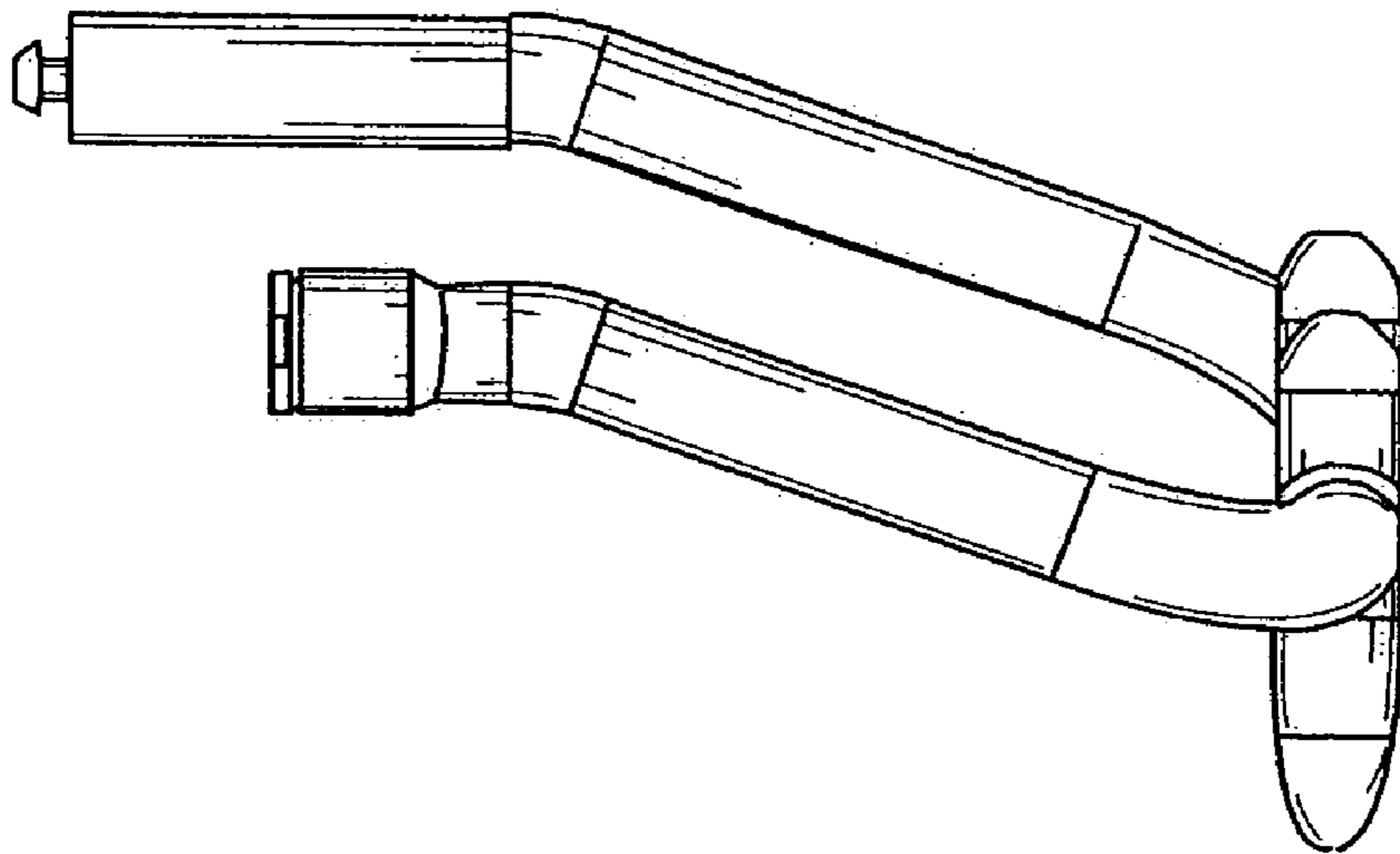

Figure 5

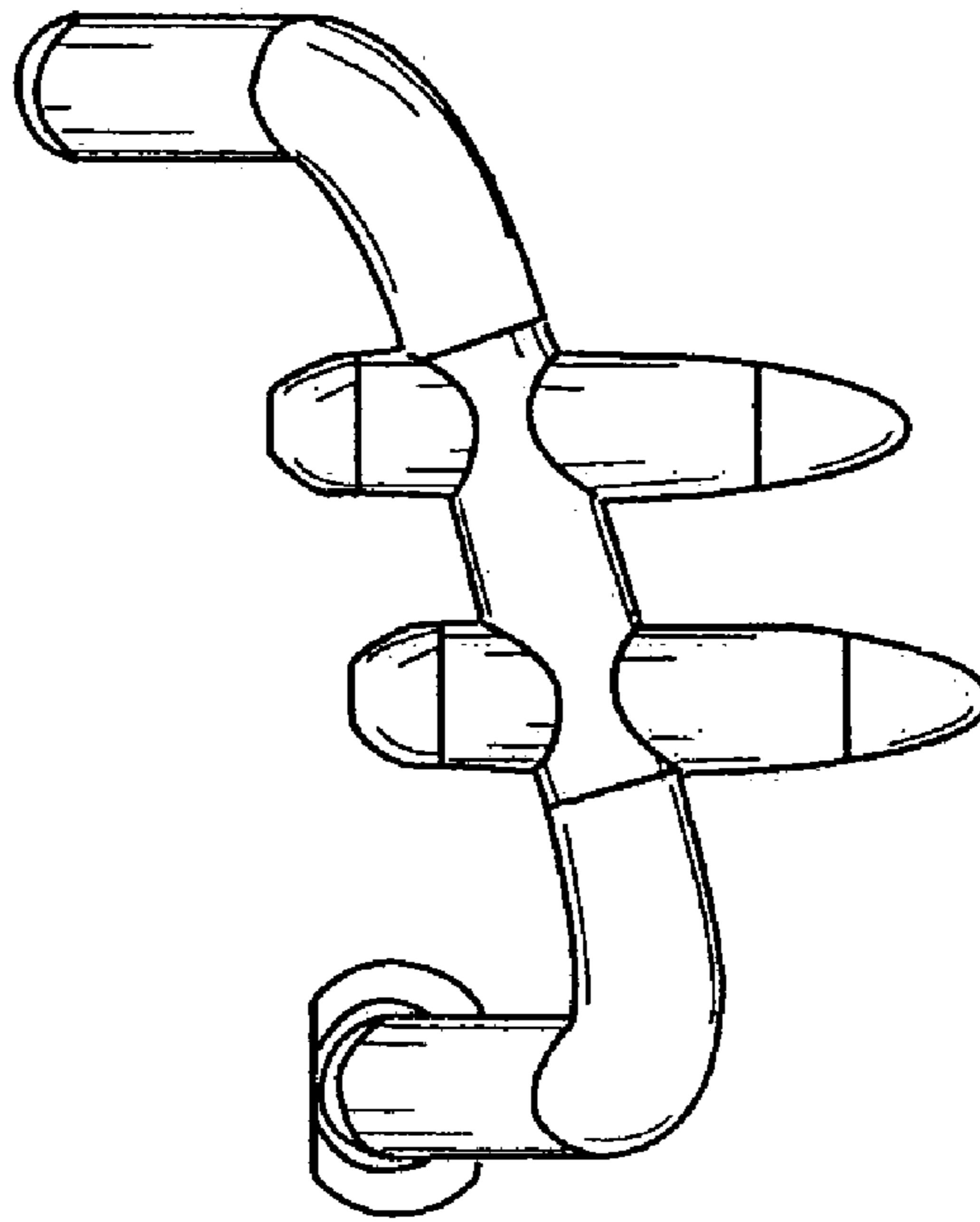

Figure 6

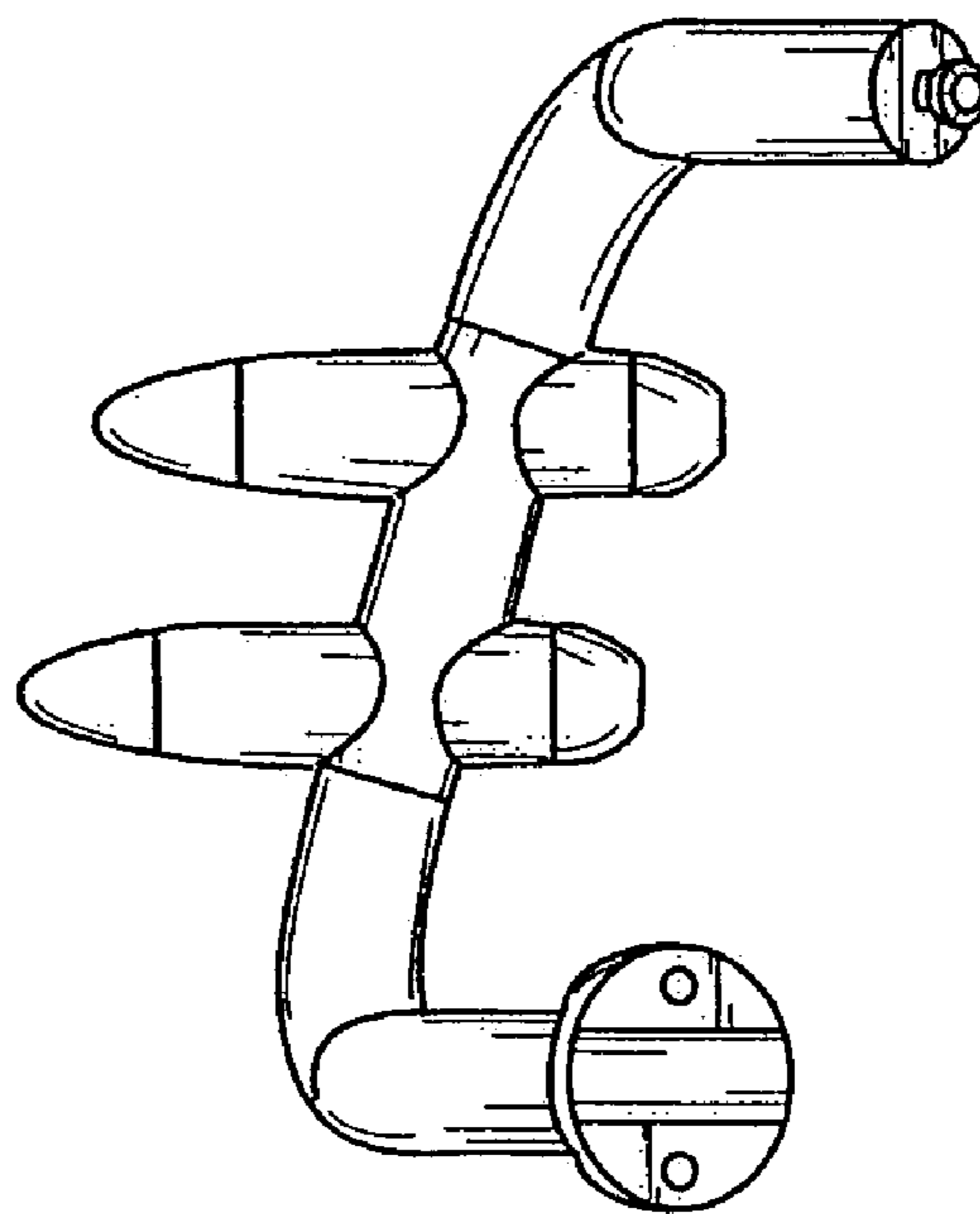

Figure 7

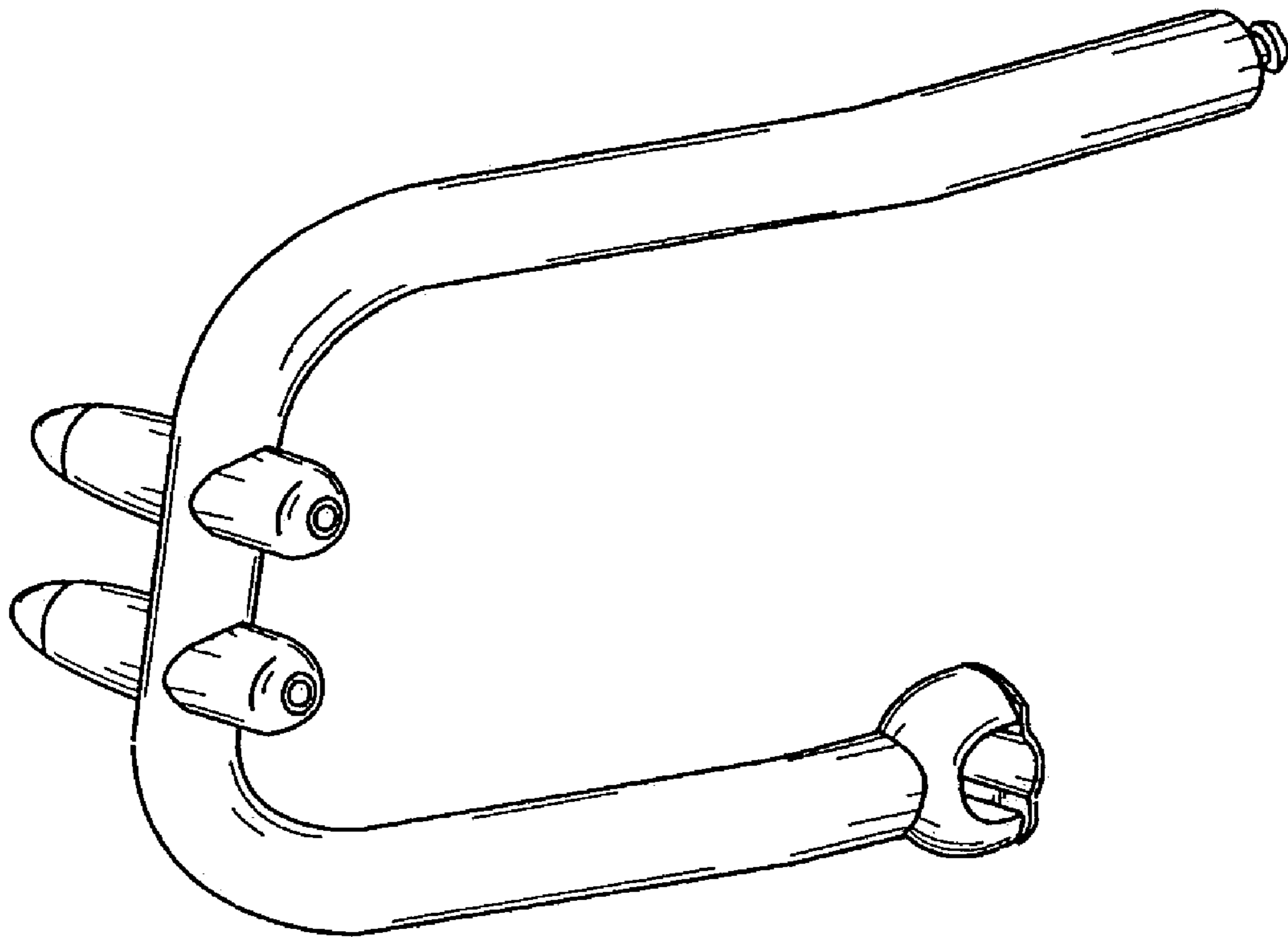

Figure 8

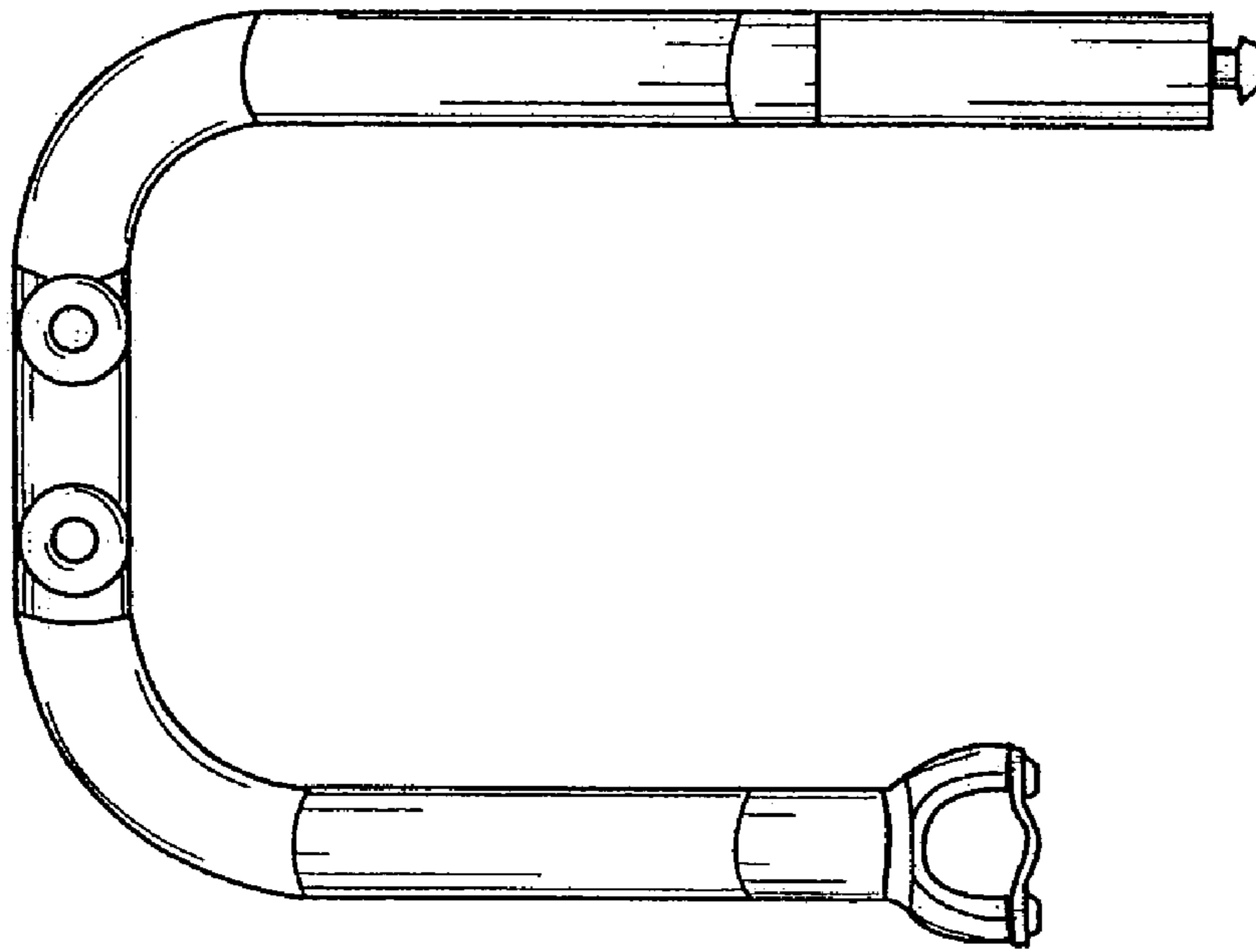

Figure 9

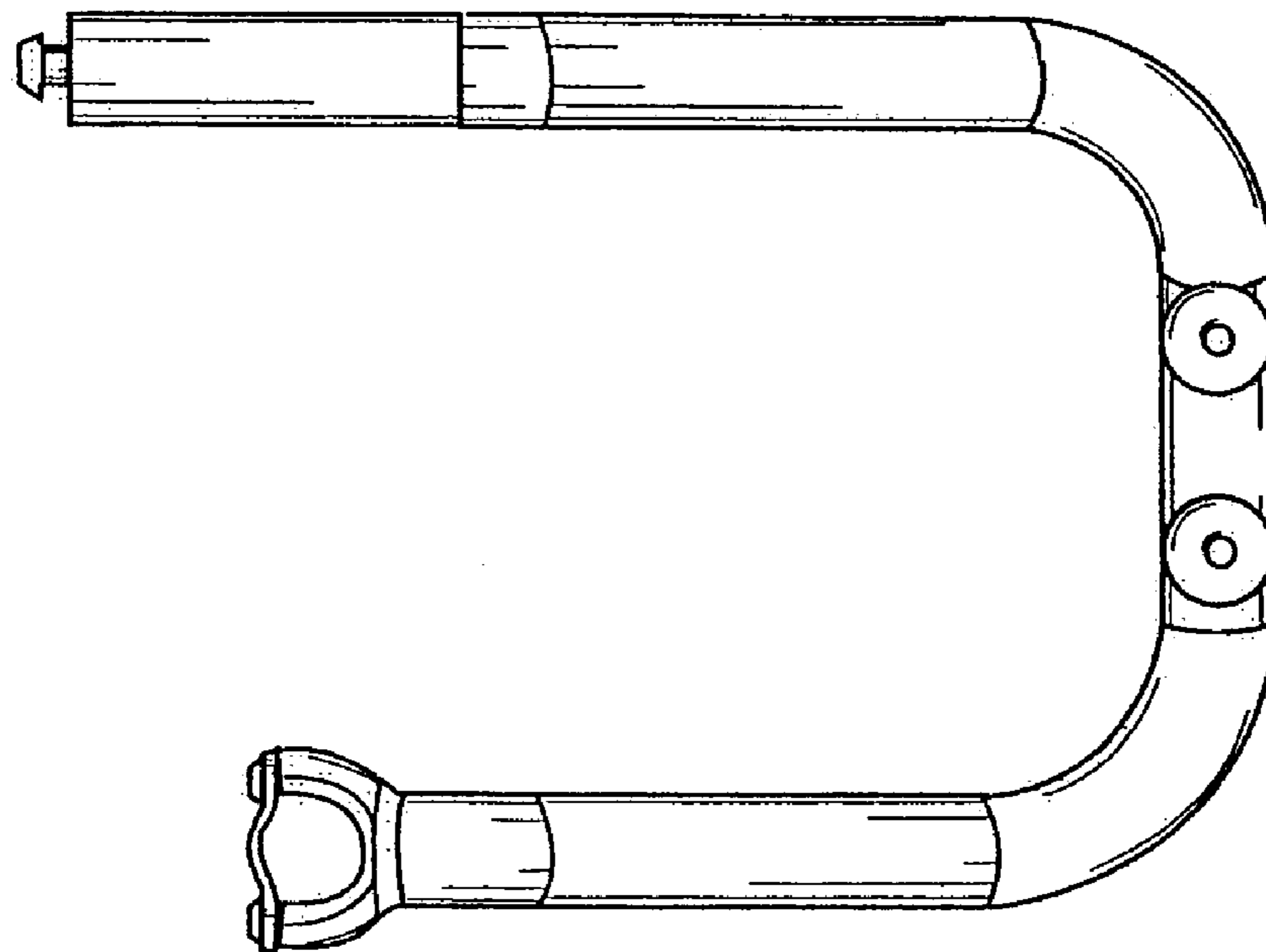

Figure 10

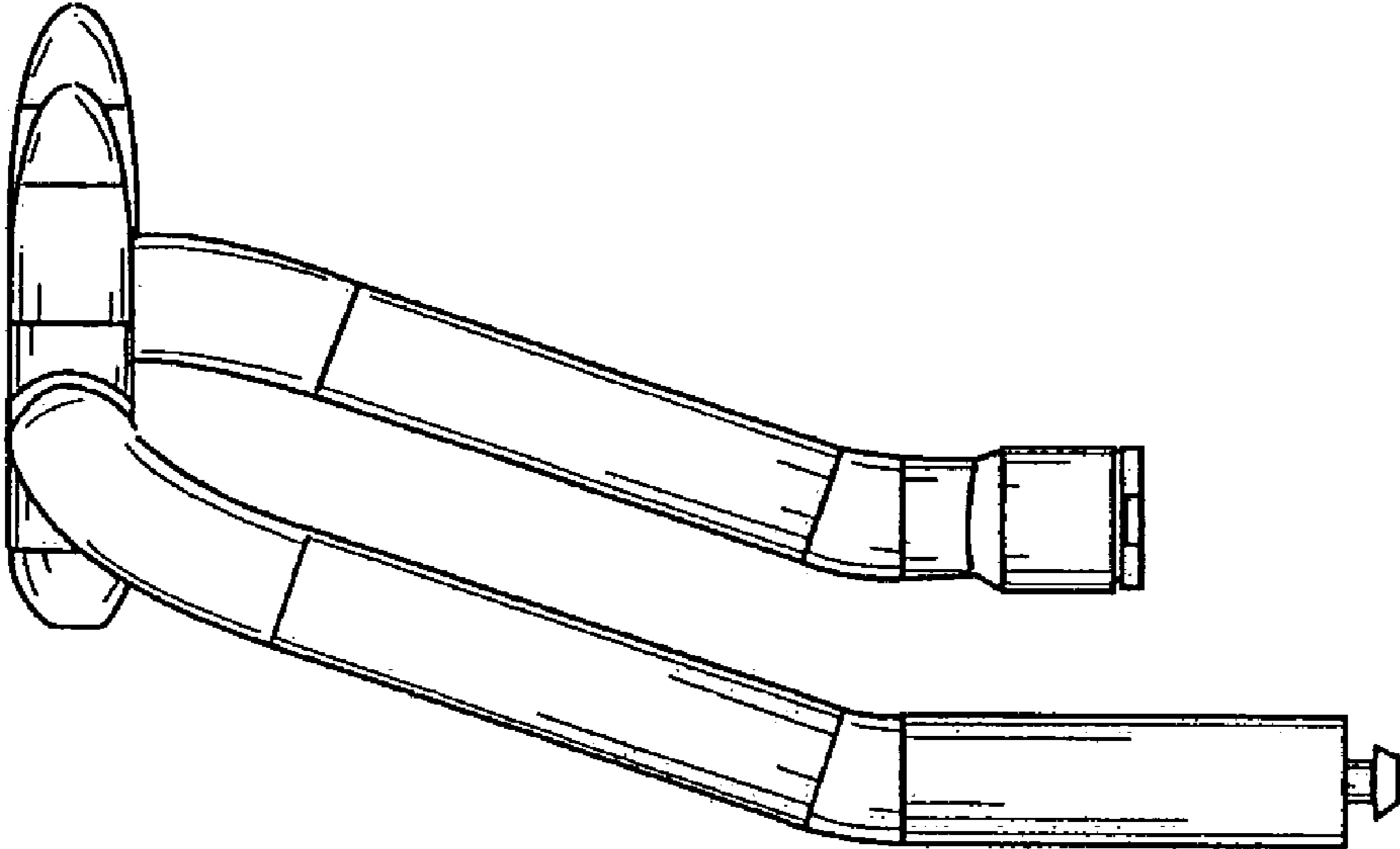

Figure 11

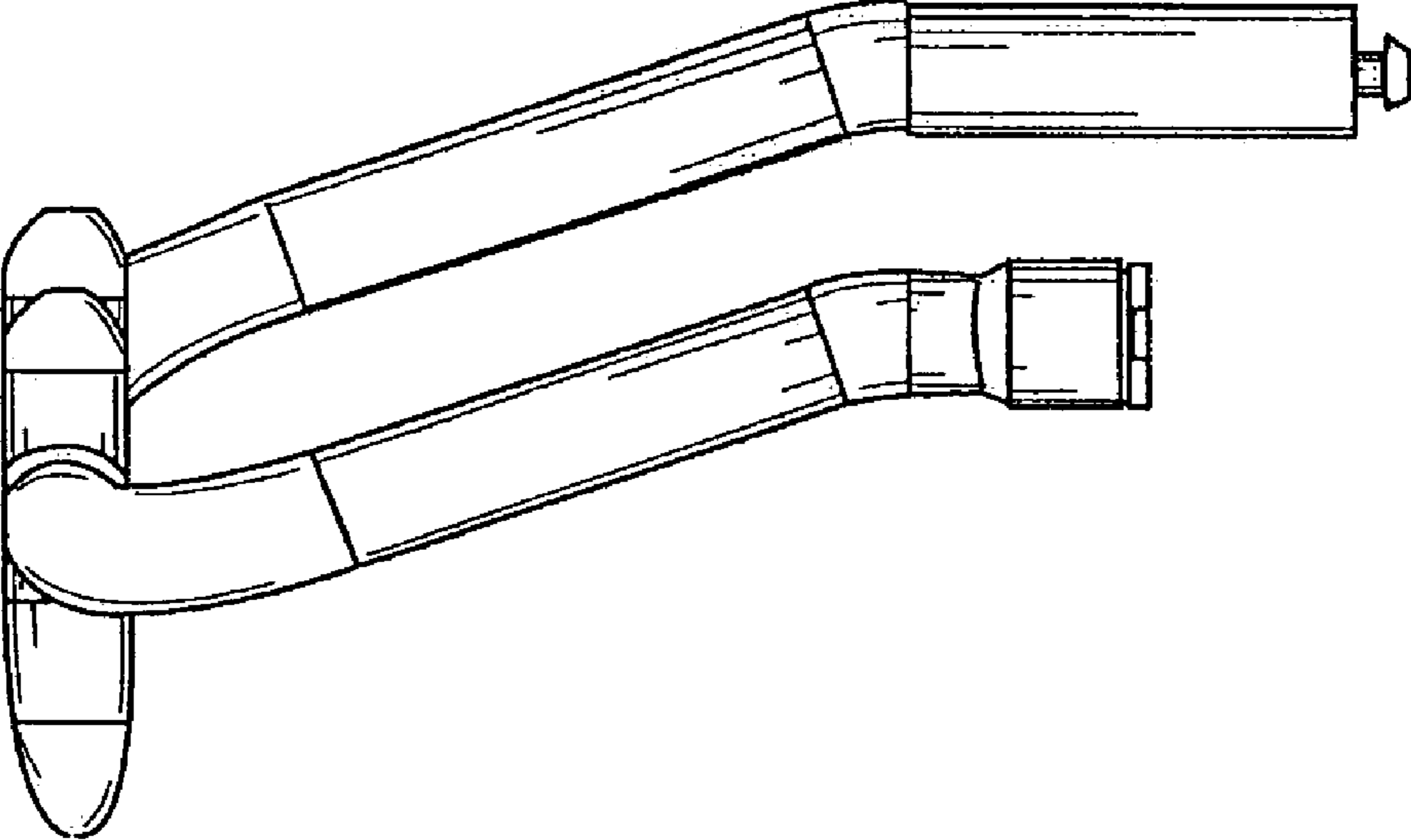

Figure 12

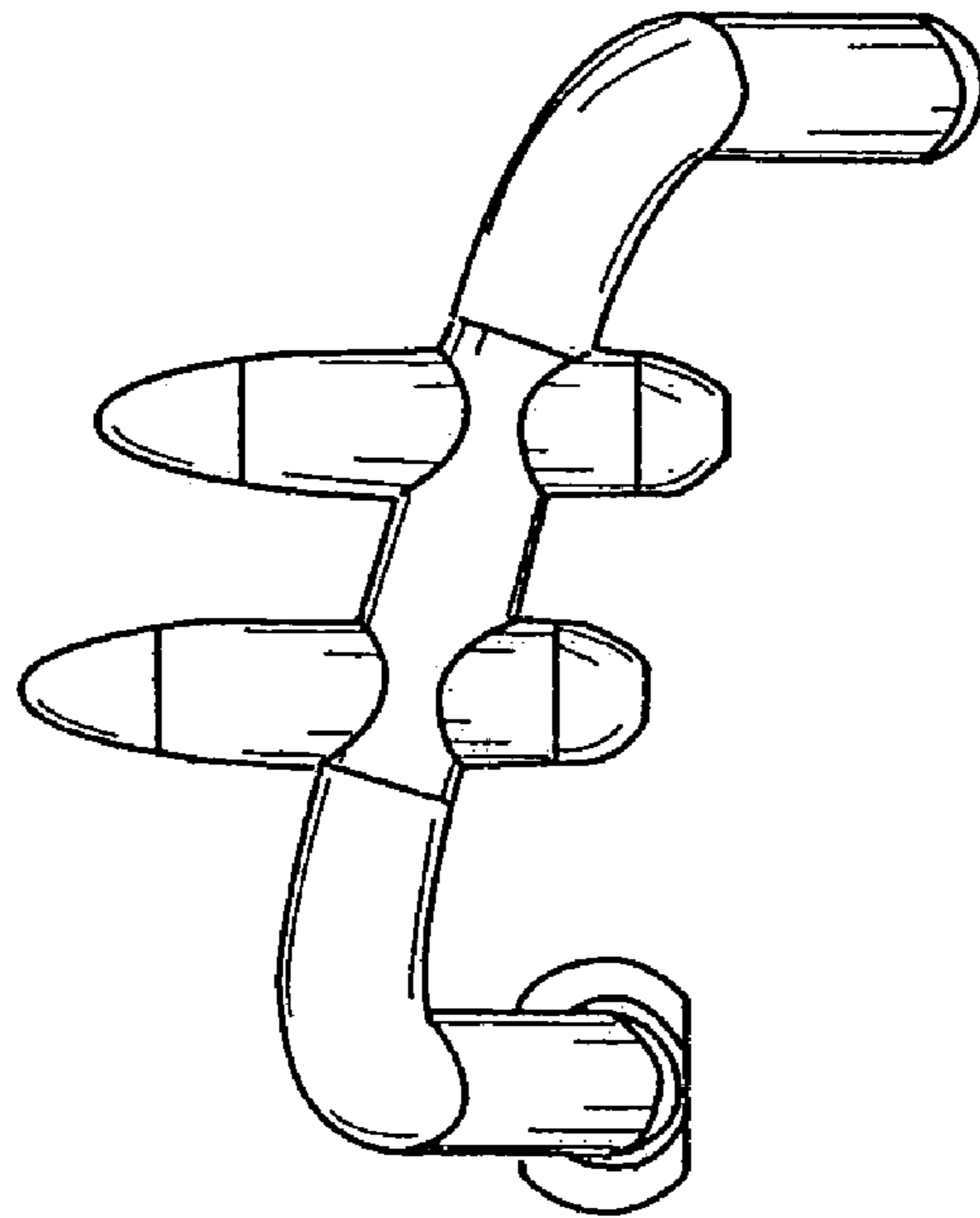

Figure 13

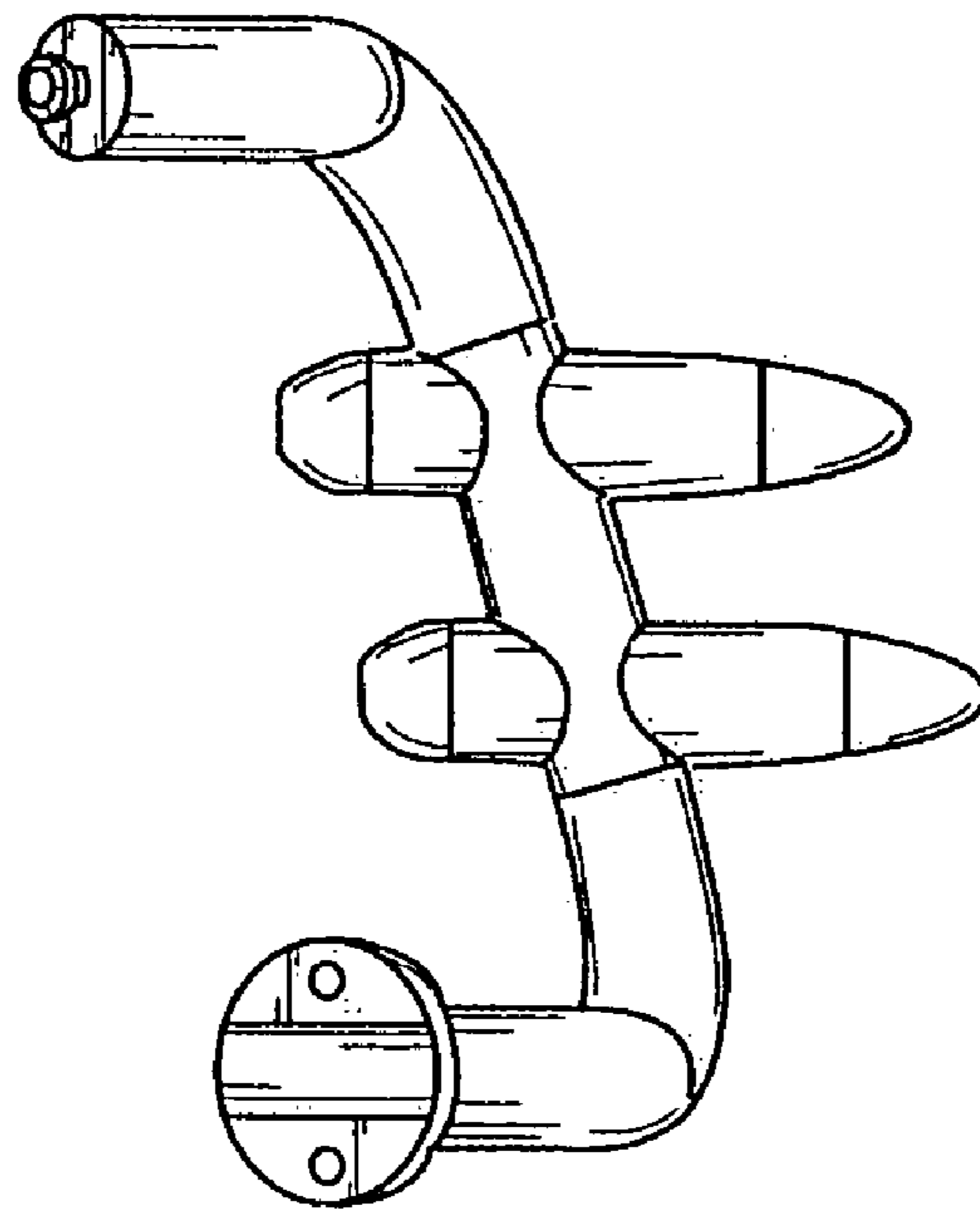

Figure 14