



US00D557035S

(12) **United States Design Patent** (10) **Patent No.:** **US D557,035 S**
Huang (45) **Date of Patent:** **** Dec. 11, 2007**

(54) **MUSIC STAND**

(76) Inventor: **Shujia Huang**, No. 3, Jianye Road,
Dadu Industrial Zone, Chencun Town,
Shunde District, Foshan City,
Guangdong Province (CN)

(**) Term: **14 Years**

(21) Appl. No.: **29/208,475**

(22) Filed: **Jun. 29, 2004**

(30) **Foreign Application Priority Data**

Dec. 30, 2003 (CN) 2003 3 0120303

(51) **LOC (8) Cl.** **06-03**

(52) **U.S. Cl.** **D6/419**

(58) **Field of Classification Search** D6/419,
D6/449, 462; 248/157, 411, 441.1, 444,
248/445, 447-449, 451-454, 457, 459, 460,
248/461.1, 462-464, 465.1; 211/13.1, 42.3,
211/85.6

See application file for complete search history.

(56) **References Cited**

U.S. PATENT DOCUMENTS

575,729	A *	1/1897	Palmer	248/448
824,596	A *	6/1906	Smith	248/457
1,359,811	A *	11/1920	Kirkendall et al.	248/462
1,879,865	A *	9/1932	Wright	248/157
1,905,109	A *	4/1933	Krauth	248/462
D120,114	S *	4/1940	Waechter	D6/496
D139,445	S *	11/1944	Barger	D6/419
6,260,812	B1 *	7/2001	Auke	248/460
D477,930	S *	8/2003	Minus	D6/419

OTHER PUBLICATIONS

K&M Sheet Music Stand 10010 black, with 1999 source code, 9 pages, www.musik-service.de, http://www.musik-service.de/KM--Sheet-Music-Stand--10010-black-prx762en.aspx.*

Music Stand Delux With Bag (Chrome), 1 page, www.Free-scores.com, http://www.free-scores.com/boutique-uk-frame-eur-acc.php?clef=52417&CATEGORIE=600.*

Yamaha Light weight black folding music stand, 2 pages, Dec. 30, 2002, www.concordmusic.com, http://www.concordmusic.com/dynamic_acc.asp?srch_category=Music+Stands.*

* cited by examiner

Primary Examiner—Robert M. Spear

Assistant Examiner—Mary Ann Calabrese

(74) *Attorney, Agent, or Firm*—Greer, Burns & Crain, Ltd.

(57) **CLAIM**

The ornamental design for a music stand, as shown and described.

DESCRIPTION

FIG. 1 is a top perspective view of the present music stand; FIG. 2 is a front view of the present music stand in an alternate position of use, with the arms in an up position and the central support unextended;

FIG. 3 is a top view of the music stand of FIG. 1;

FIG. 4 is a left side view of same;

FIG. 5 is a right side view of the music stand of FIG. 1;

FIG. 6 is a bottom view of the present music stand;

FIG. 7 is a rear view of the music stand of FIG. 1; and,

FIG. 8 is a top perspective view of the music stand of FIG. 1 shown in an alternate position with the arms slanted half up and the central support extended.

1 Claim, 8 Drawing Sheets

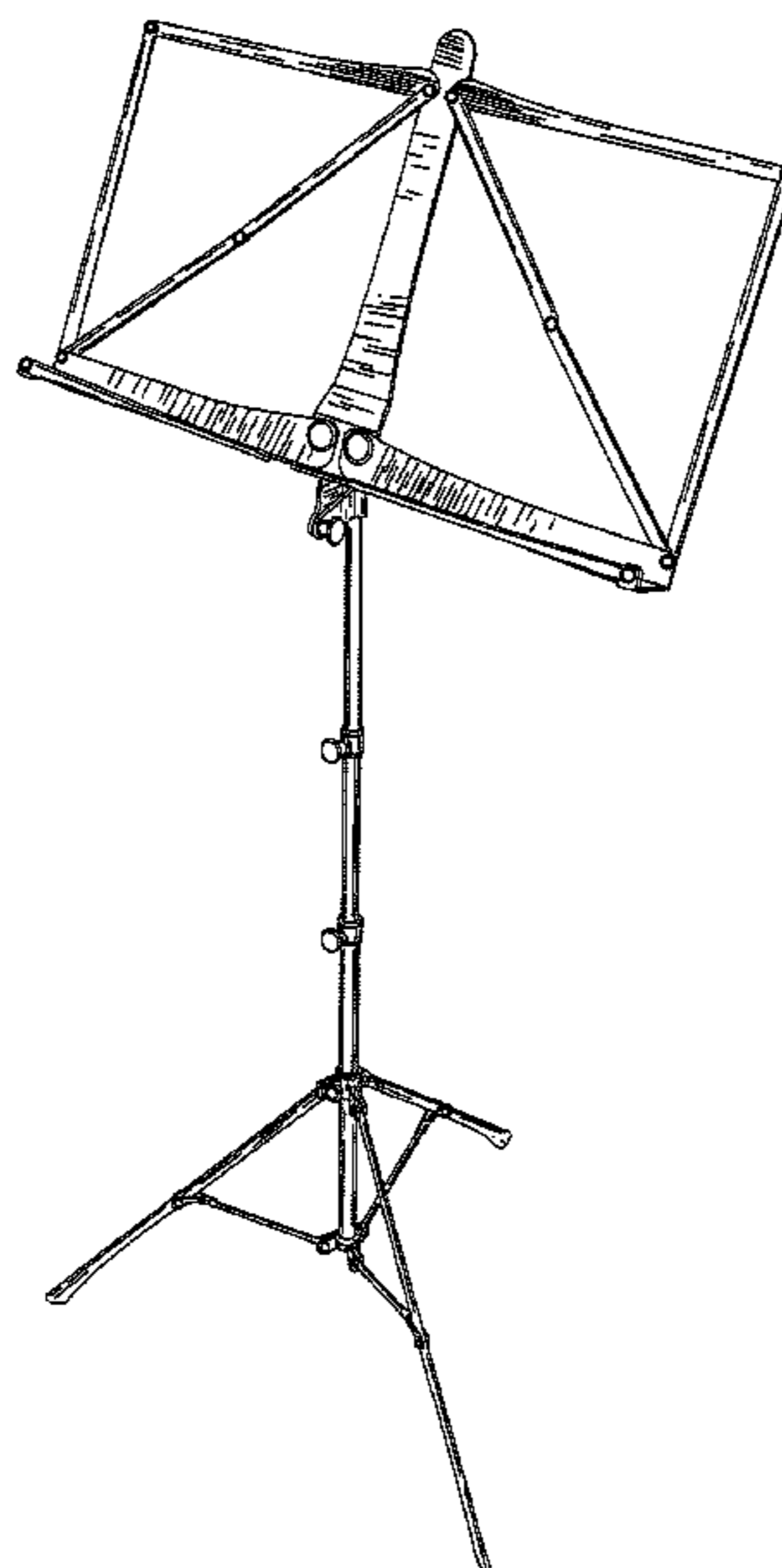

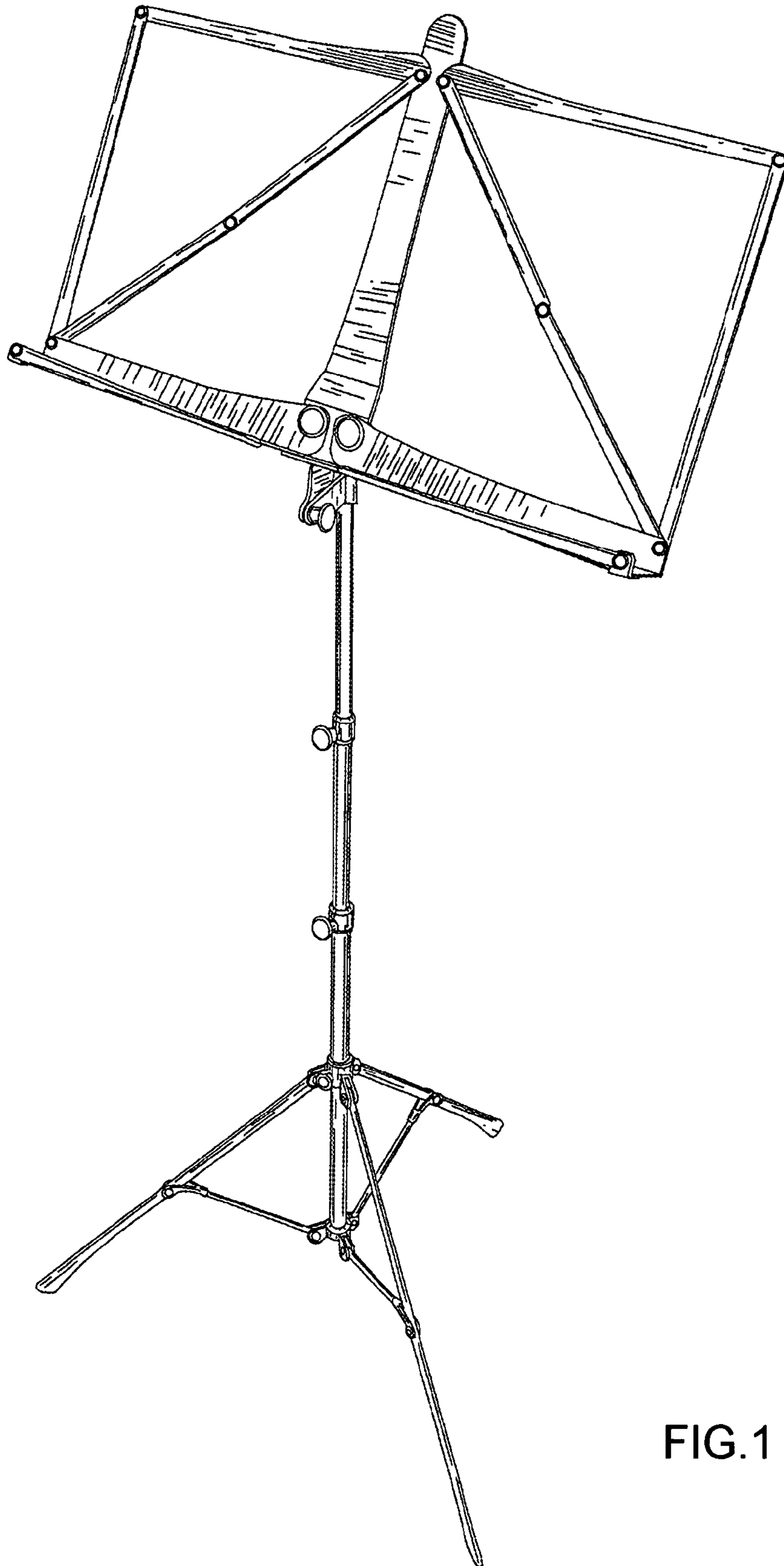

FIG.1

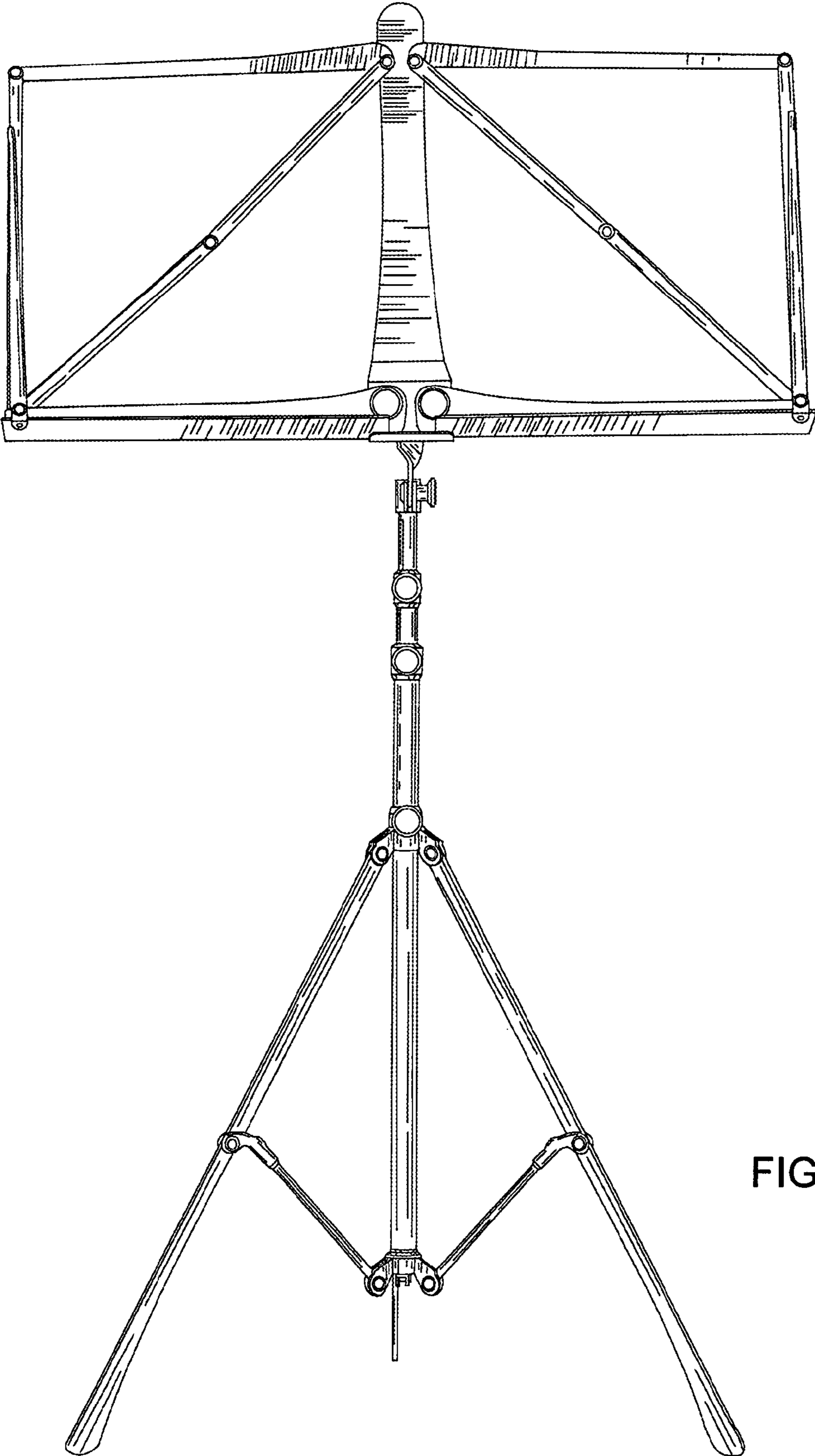

FIG.2

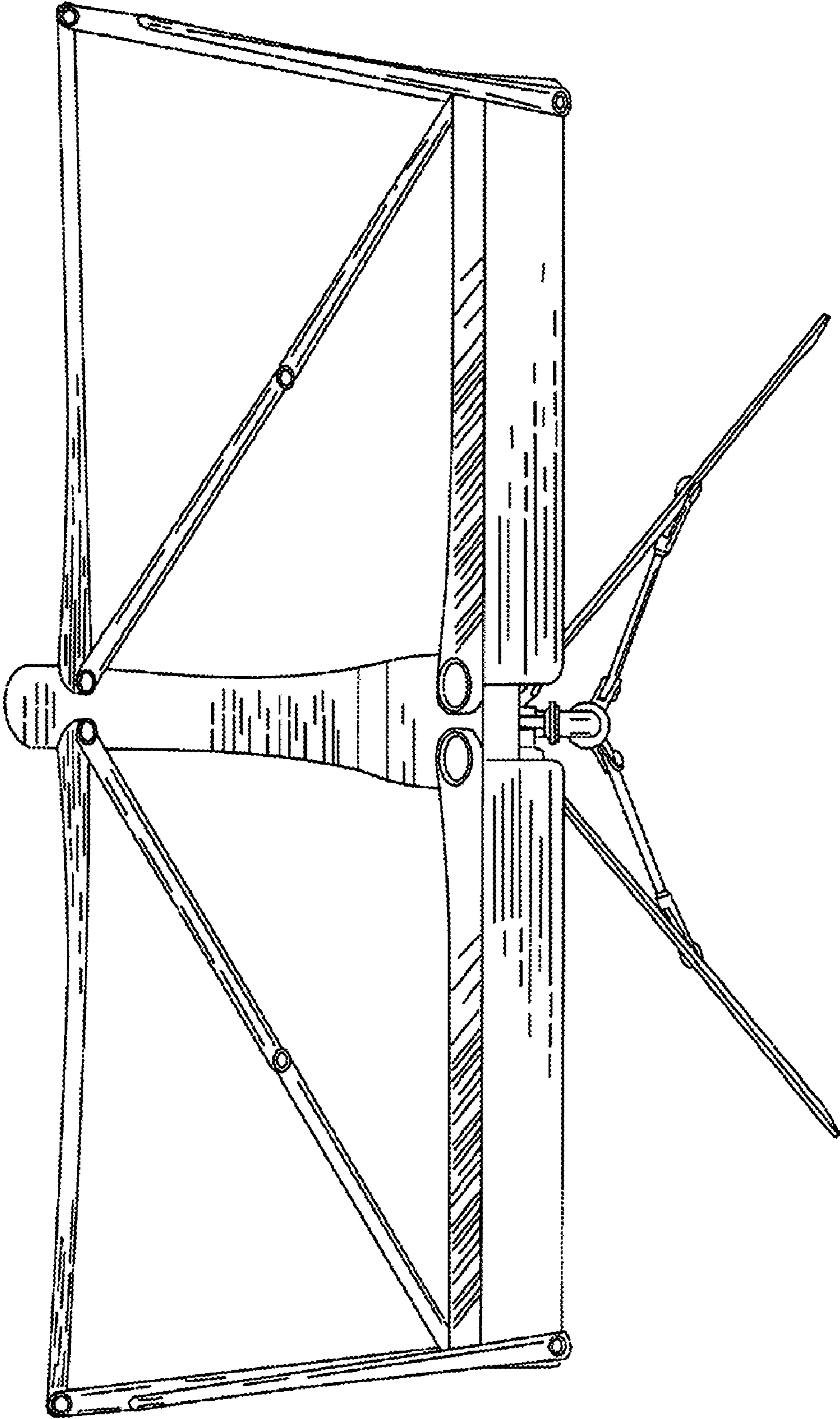

FIG.3

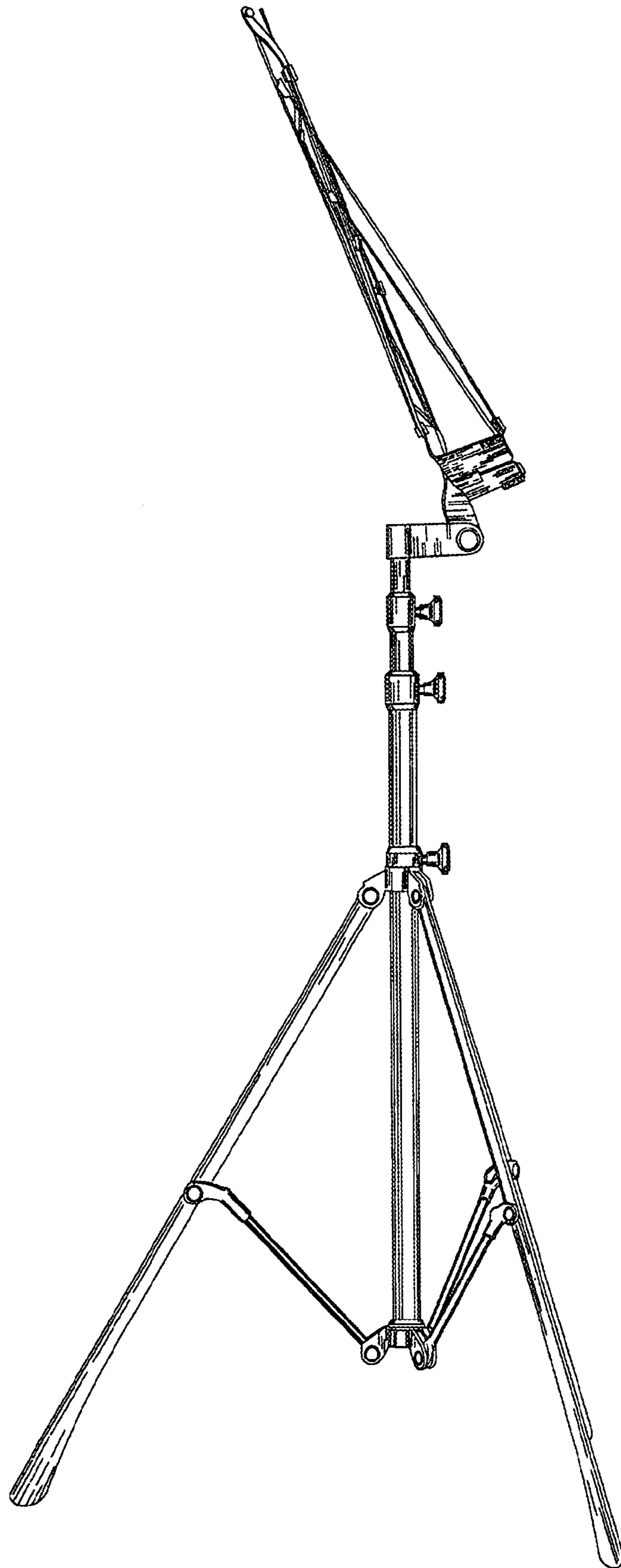

FIG.4

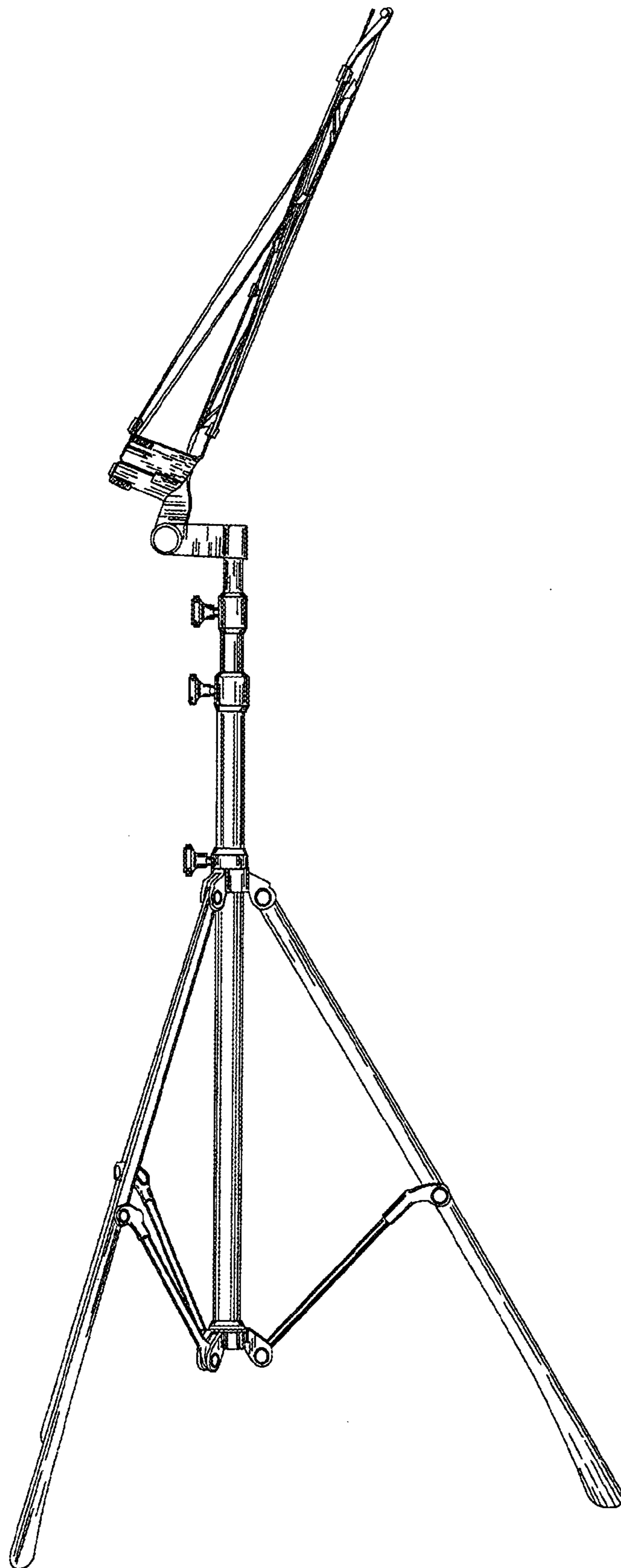

FIG.5

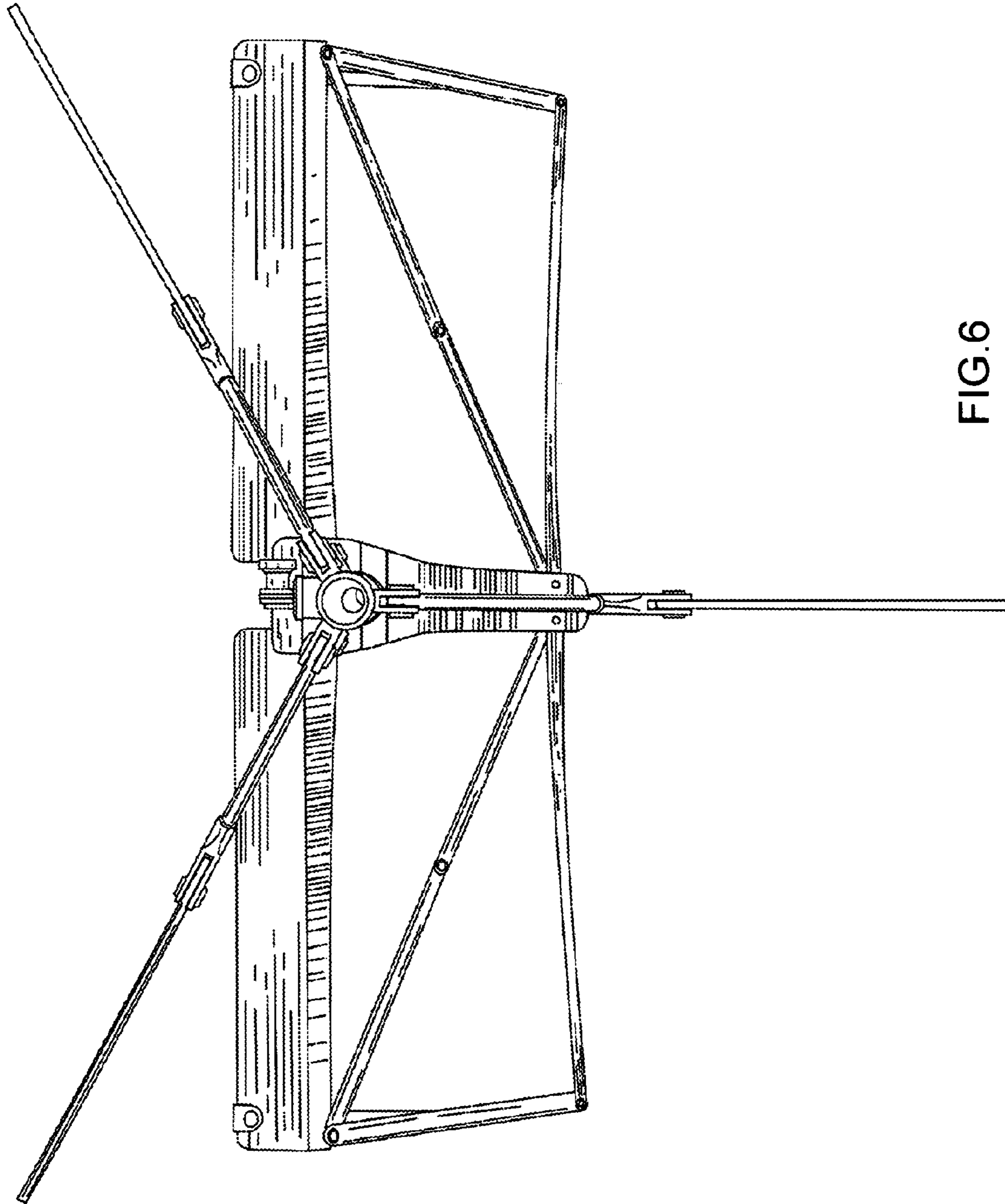

FIG.6

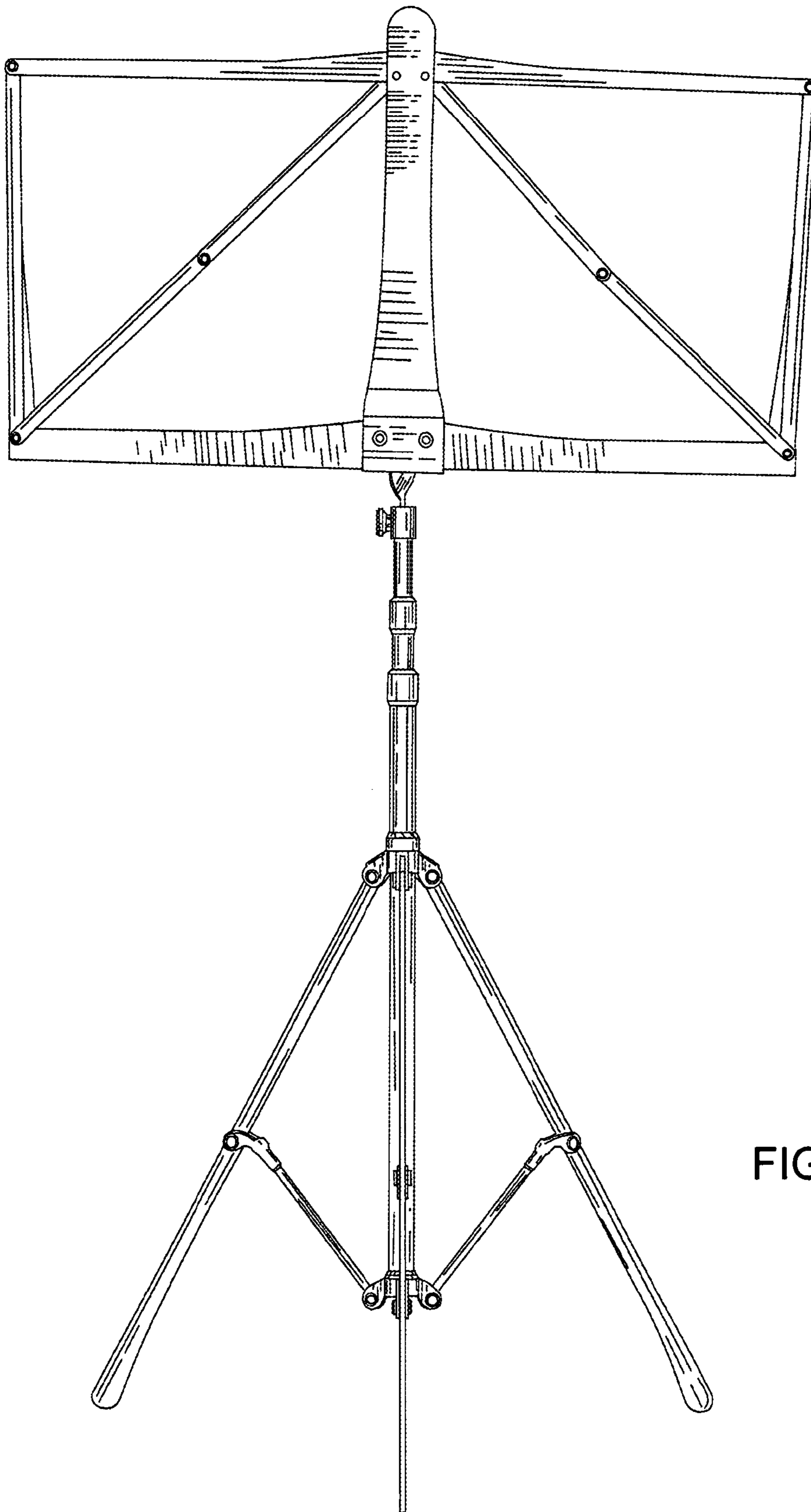

FIG.7

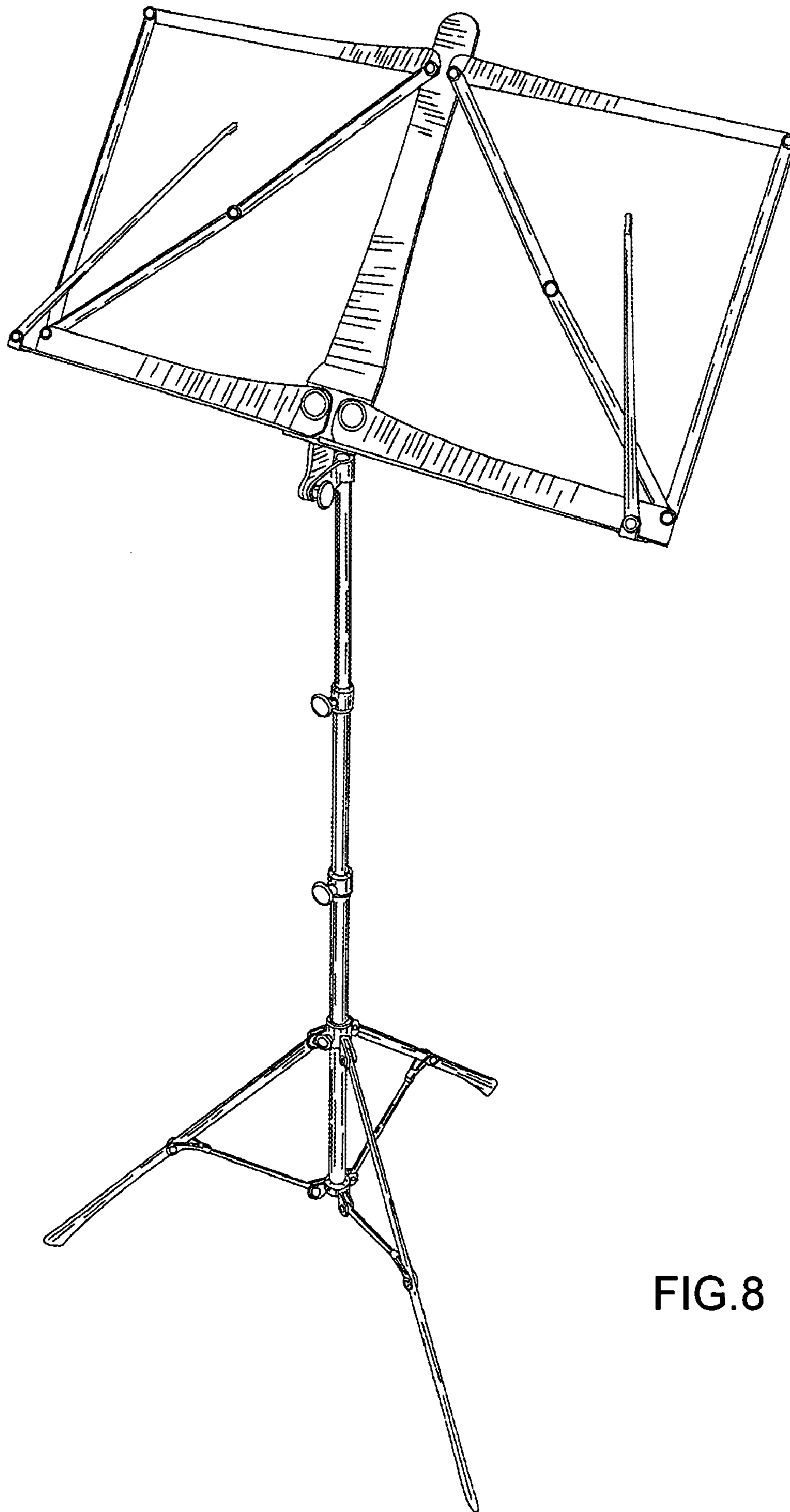

FIG.8