



US00D556648S

(12) **United States Design Patent** (10) **Patent No.:** **US D556,648 S**
Nelson et al. (45) **Date of Patent:** **** Dec. 4, 2007**

(54) **TAPERED DRIVE SHAFT HOUSING**

D491,843 S * 6/2004 Giugiaro D12/88
7,073,824 B2 * 7/2006 Uhara et al. D12/218

(75) Inventors: **Gary Alan Nelson**, Concord, NC (US);
Michael Dean Horton, Concord, NC
(US); **Donald E. Krueger**, Stony Point,
NC (US)

* cited by examiner

Primary Examiner—Ian Simmons
Assistant Examiner—Michael A. Pratt
(74) *Attorney, Agent, or Firm*—Alston & Bird LLP

(73) Assignee: **National Association for Stock Car
Auto Racing, Inc.**, Daytona Beach, FL
(US)

(57) **CLAIM**

The ornamental design for a tapered drive shaft housing, as
shown and described.

(**) Term: **14 Years**

(21) Appl. No.: **29/229,256**

DESCRIPTION

(22) Filed: **May 5, 2005**

FIG. 1 is a perspective view of a tapered drive shaft housing
according to our new design;

(51) **LOC (8) Cl.** **12-16**

FIG. 2 is another perspective view thereof;

(52) **U.S. Cl.** **D12/159**

FIG. 3 is a top plan view thereof;

(58) **Field of Classification Search** D12/87,
D12/88, 93, 159, 160, 161, 400; 280/5.5–5.524;
296/181.1, 187.01, 187.08, 204, 205
See application file for complete search history.

FIG. 4 is a bottom plan view thereof;

FIG. 5 is a left side elevation view thereof;

FIG. 6 is a right side elevation view thereof;

FIG. 7 is a rear elevation view thereof; and,

FIG. 8 is a front elevation view thereof.

(56) **References Cited**

The broken lines shown herein are for illustrative purposes
only and form no part of the claimed design.

U.S. PATENT DOCUMENTS

D26,223 S * 10/1896 Studebaker D12/160
2,908,528 A * 10/1959 Richter D12/87
3,366,411 A * 1/1968 Vittone D12/87

1 Claim, 7 Drawing Sheets

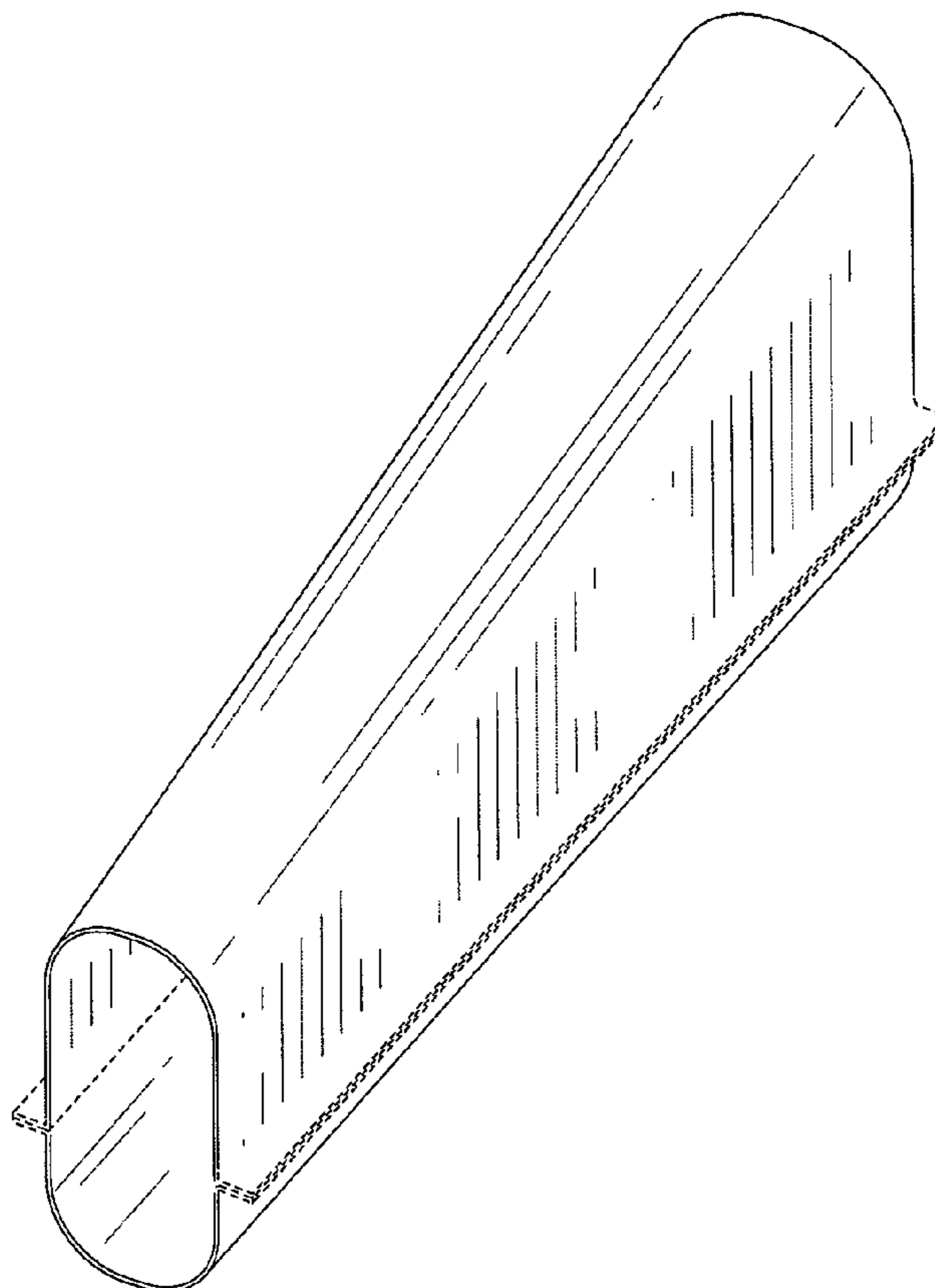

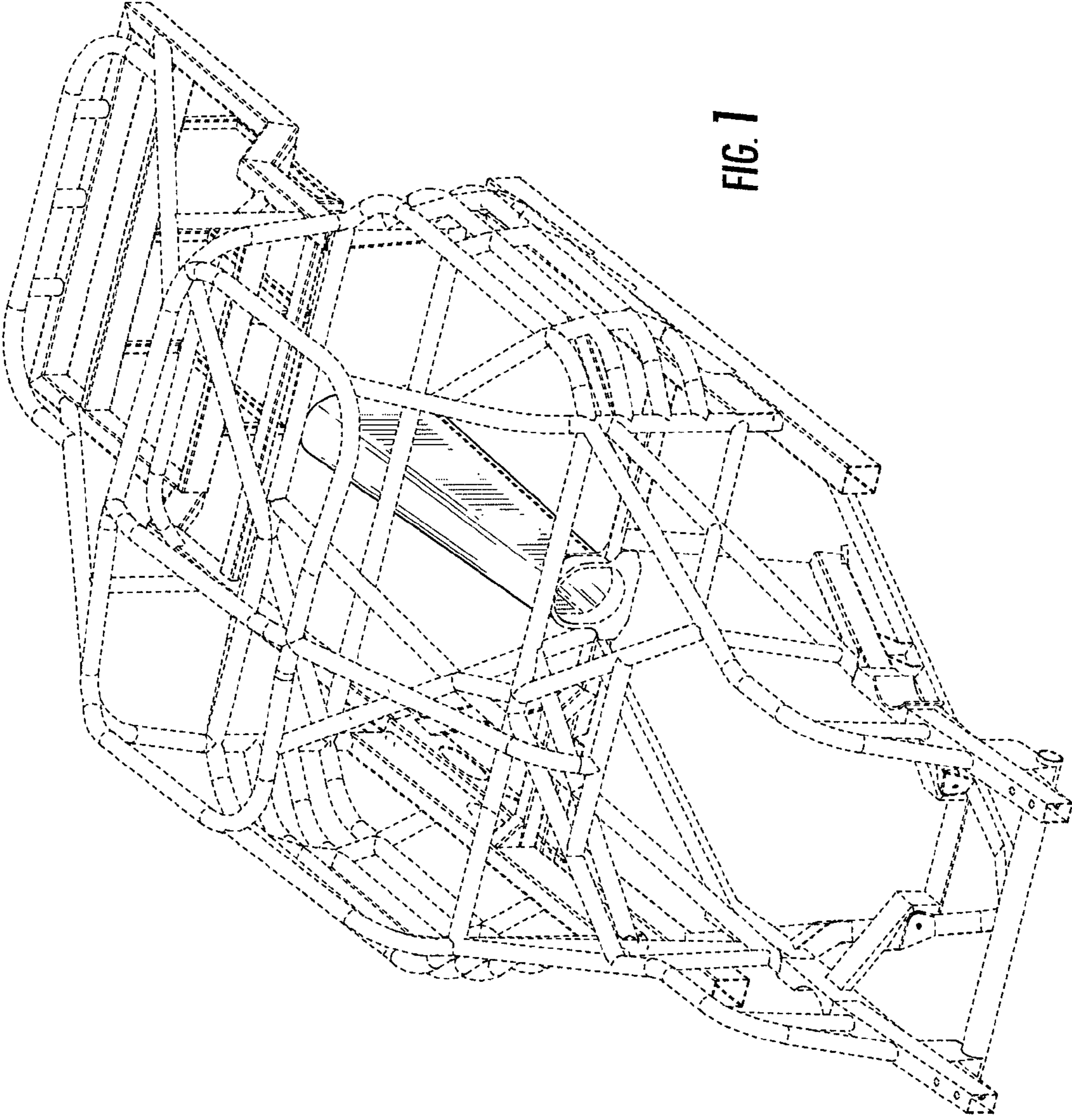

FIG. 7

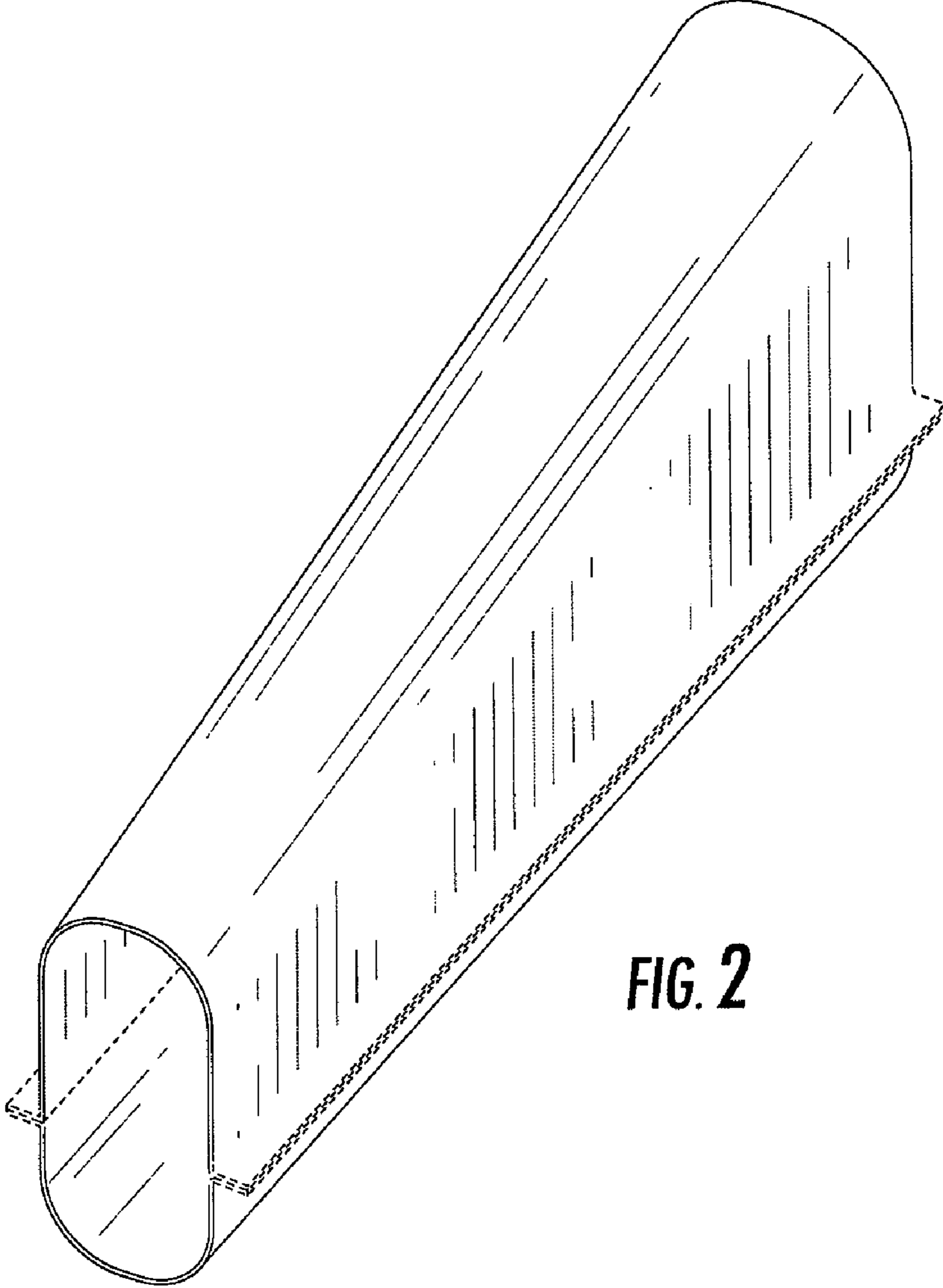

FIG. 2

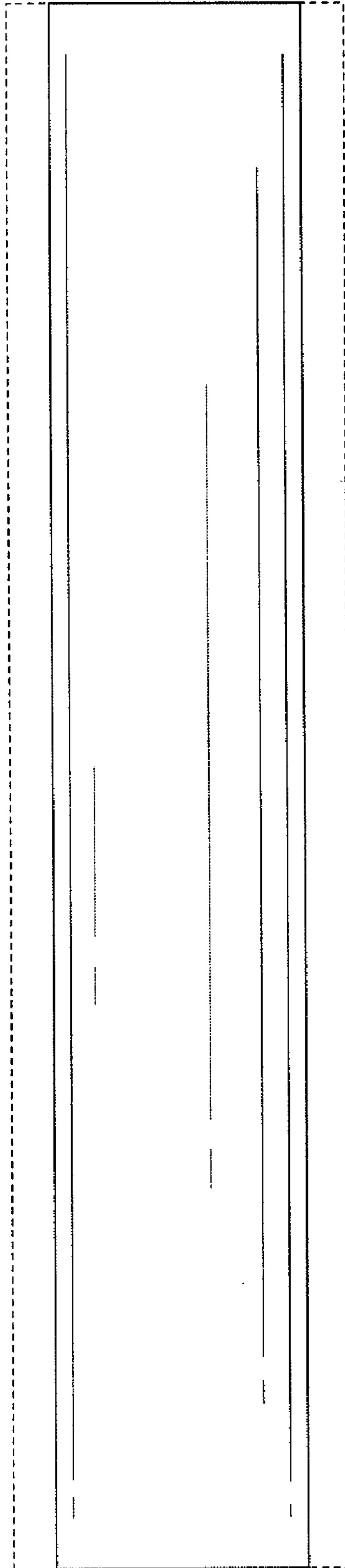

FIG. 3

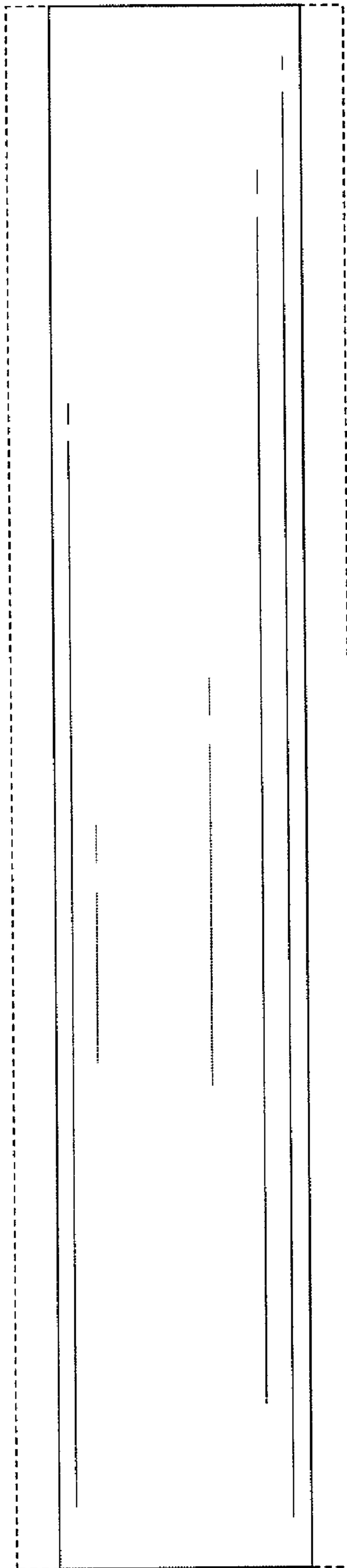

FIG. 4

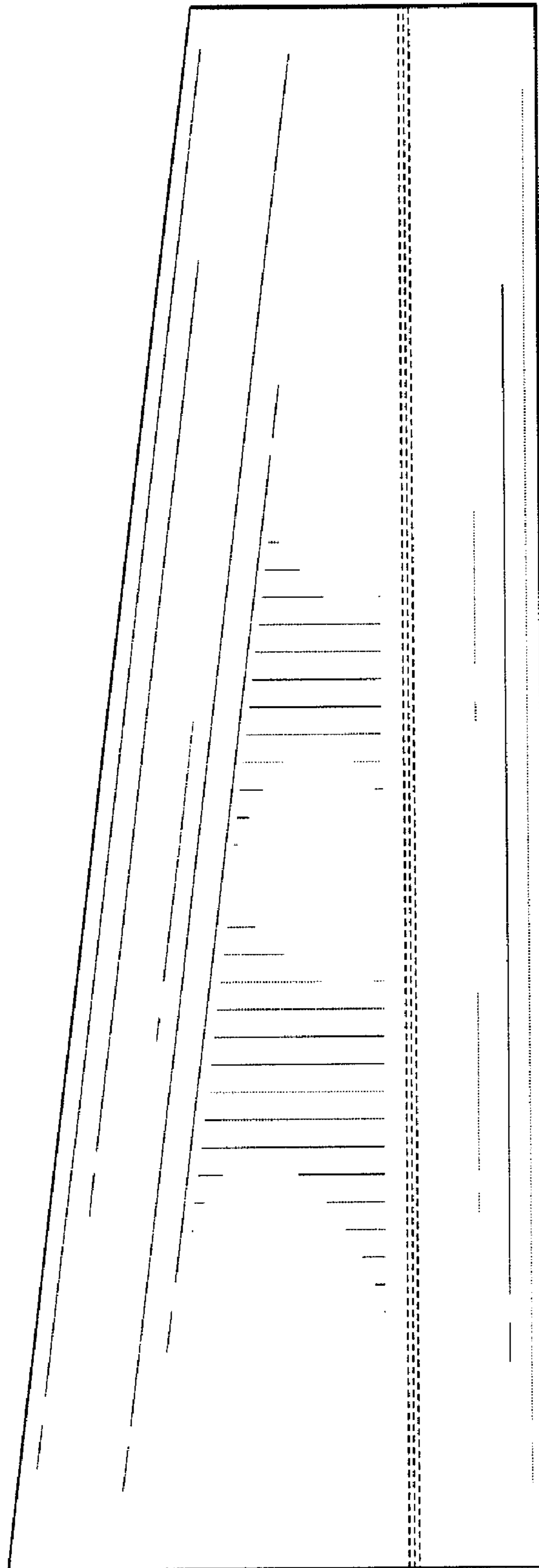

FIG. 5

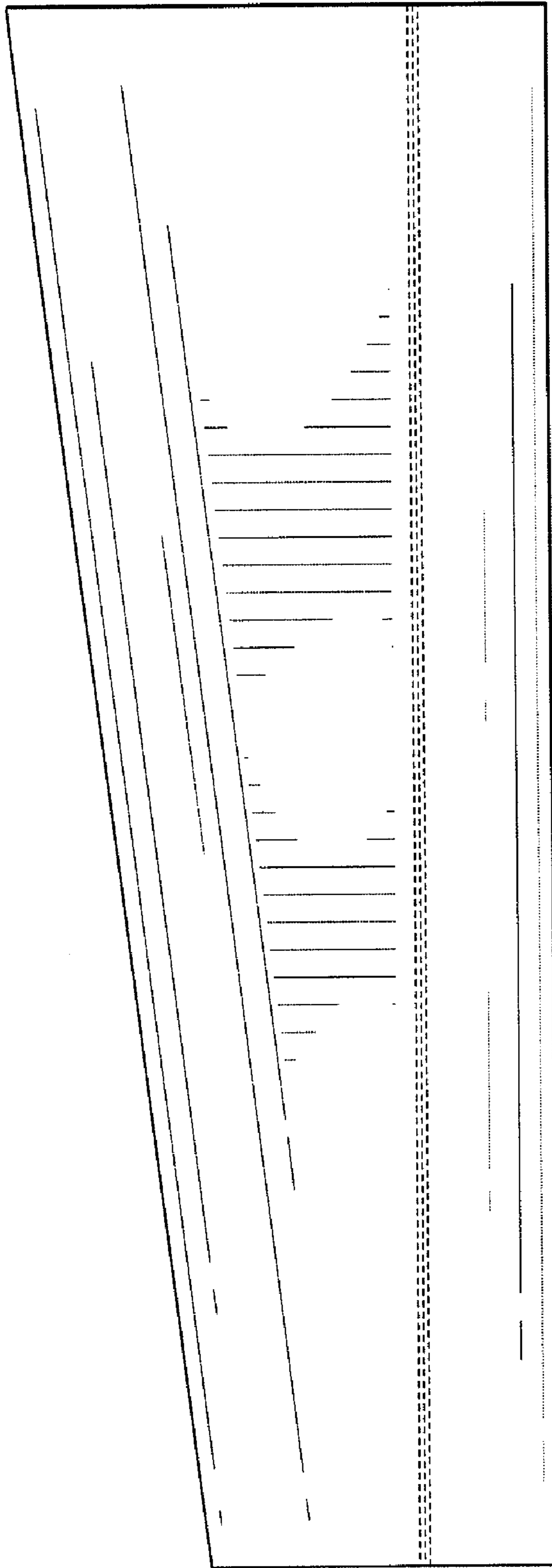

FIG. 6

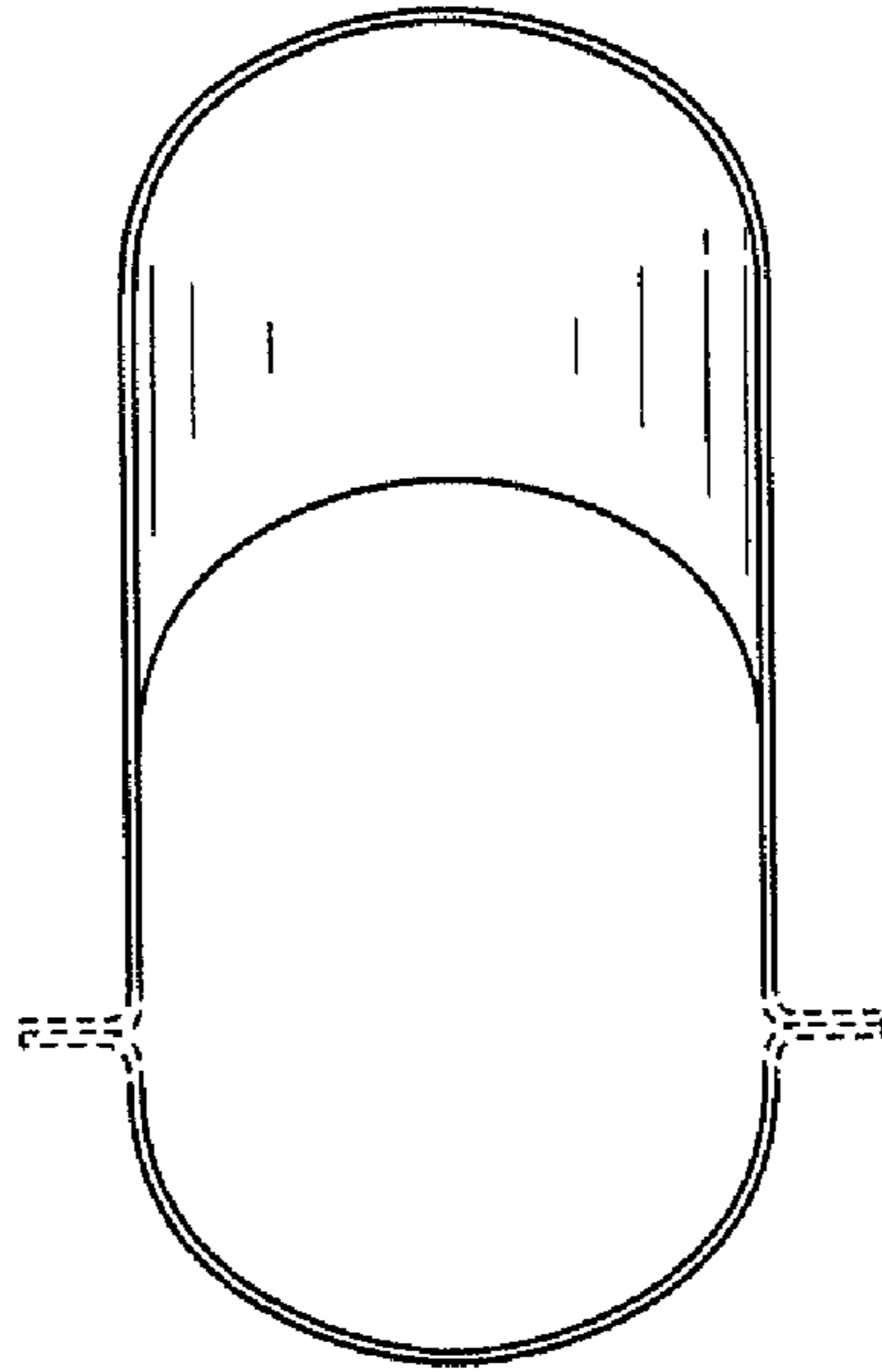

FIG. 7

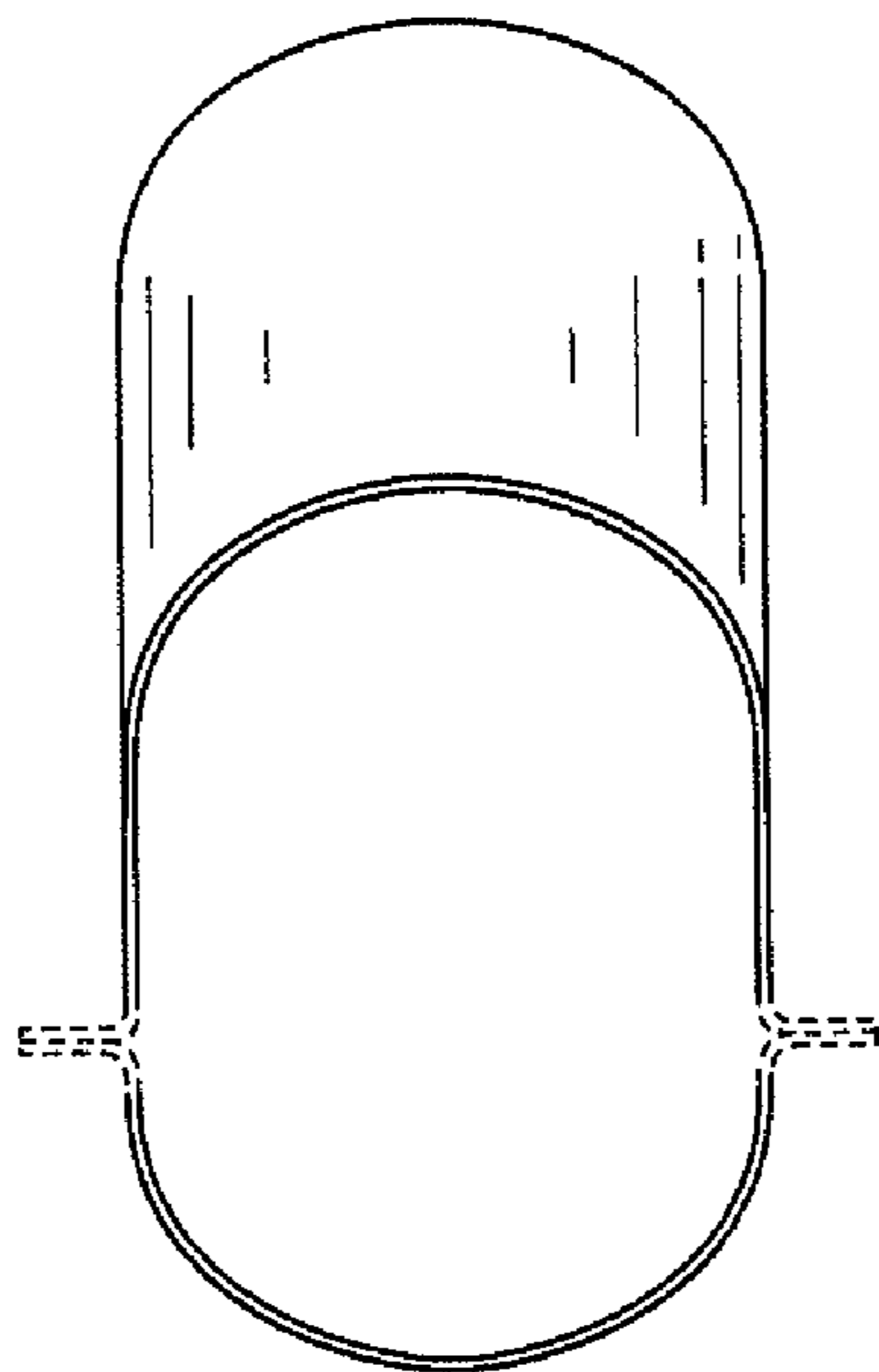

FIG. 8