



US00D556110S

(12) **United States Design Patent** (10) **Patent No.:** **US D556,110 S**
Schiavone et al. (45) **Date of Patent:** **** Nov. 27, 2007**

(54) **VEHICLE TAILGATE**

(75) Inventors: **Patrick Schiavone**, Bloomfield, MI (US); **Gordon Platto**, Troy, MI (US); **Michael Smith**, Plymouth, MI (US)

(73) Assignee: **Ford Global Technologies, LLC**, Dearborn, MI (US)

(**) Term: **14 Years**

(21) Appl. No.: **29/246,016**

(22) Filed: **Dec. 21, 2005**

(51) **LOC (8) Cl.** **12-16**

(52) **U.S. Cl.** **D12/196**

(58) **Field of Classification Search** D12/196, D12/98, 93; 296/57.1, 3, 26, 50, 37.1, 37.6

See application file for complete search history.

(56) **References Cited**

U.S. PATENT DOCUMENTS

D352,262 S	*	11/1994	Hawkes et al.	D12/196
D391,545 S	*	3/1998	Arndt et al.	D12/221
D474,727 S	*	5/2003	Scheffert	D12/196
D481,339 S	*	10/2003	McClellan et al.	D12/196
D494,521 S	*	8/2004	Metros et al.	D12/196
D494,910 S	*	8/2004	Metros et al.	D12/196
D527,697 S	*	9/2006	Metros et al.	D12/196

OTHER PUBLICATIONS

Pickup Truck.com, *Caught! 2005 Ford F-350 Super Duty*, Aug. 4, 2003 <http://www.pickuptruck.com/html/2005/ford/superduty/caught.html>.

Automotive News Online, *Ford modifies '05 F-series Super Duty pickups*, May 24, 2004 <http://www.autonews.com/article.cms?articleId=48362>.

Detroit News Online, *Ford tests a hydrogen F-350*, Sep. 7, 2004 <http://www.detnews.com/2004/autoinsider/0409/07/b01-265187.htm>.

Detroit News Online, *Ford's Super Duty pickups due for major makeover*, Dec. 22, 2004 <http://info.detnews.com/autoinsider/sneakpeek/index.cfm?id=17263>.

FordForums.com, *US: Spy Shot: 2007 Ford F-Series Super Duty*, Dec. 24, 2004 <http://www.fordforums.com/showthread.php?t=93973>.

Motor Trend's Truck Trend, News Front: *Spied—2007 Super Duty*, p. 16, Mar./Apr. 2005.

CarSpyShots.net, *2007 Ford SuperDutys (f250,f350)*, Jul. 23, 2005 <http://www.carspyshots.net/zerthread?id=16073>.

CarSpyShots.net, *Re: (CD-BP)*, Sep. 1, 2005 <http://www.carspyshots.net/zerthread?id=16073>.

TheCarConnection.com, *Ford Excursion Sinks into History*, Sep. 25, 2005 http://www.thecarconnection.com/Auto_News/Daily_Edition/Daily_Edition_Sept_30%20Oct_3_2005.S173.A9375.html.

The Detroit News (detnews.com), *Autos Insider: Out of Gas: Ford's fuel-guzzling Excursion reaches end of line*, Sep. 30, 2005 <http://www.detnews.com/2005/autosinsider/0509/30/C01-332800.htm?r=truckblog.com>.

(Continued)

Primary Examiner—Melody N. Brown

(74) *Attorney, Agent, or Firm*—Damian Porcari

(57) **CLAIM**

The ornamental design for a vehicle tailgate, as shown and described.

DESCRIPTION

FIG. 1 is a rear perspective view of a vehicle tailgate showing our new design;

FIG. 2 is a rear elevational view thereof;

FIG. 3 is a front elevational view thereof;

FIG. 4 is a right side elevational view thereof;

FIG. 5 is a left side elevational view thereof;

FIG. 6 is a top plan view thereof; and,

FIG. 7 is a bottom plan view thereof.

The broken lines shown throughout the drawing are for illustrative purposes only and form no part of the claimed design.

1 Claim, 6 Drawing Sheets

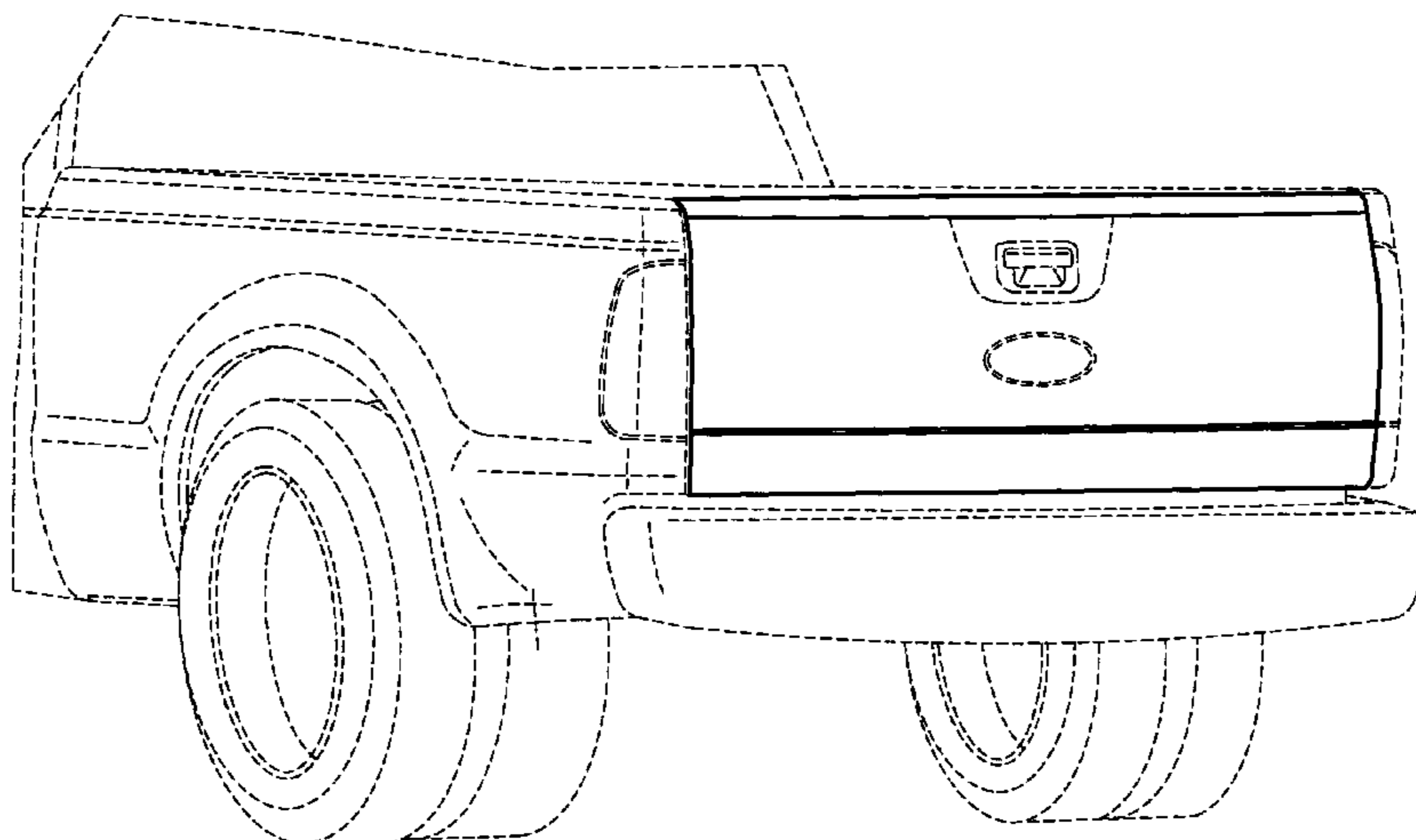

OTHER PUBLICATIONS

Edmunds.com, *2007 Ford F250/F350 Large Truck*, date unknown <http://www.edmunds.com/future/2007/ford/f250f350/100491426/preview.html>.

Edmunds.com, *Inside Line: 2005 Excursion*, date unknown <http://www.edmunds.com/insideline/do/ViewModelDetail/make=Ford/model=Excursion>.

Ford Vehicles, *2005 Ford Excursion*, date unknown <http://www.fordvehicles.com/suvs/excursion/>.

Chevrolet S10 LS Ext. Cab Fleetside –198–Detroit 2000.

Chevrolet Silverado 2000 LS 1500 –198 –Detroit 2000.

Dodge Dakota Quad Cab Sport Plus –198 –Detroit 2000.

Dodge Maxx Caab Concept –198 –Detroit 2000.

Dodge Ram 1500 SLT Laramie V8 Magnum –198 –Detroit 2000.

Ford Concept 24.7 Orange –198 –Detroit 2000.

Ford Concept Super Shief F350 –Back –Detroit 2006.

Ford Explorer Sport Trac –198 –Detroit 2000.

Ford F150 Harley Davidson –Trunk –Chicago 2005.

Ford F150 Lariat 5.4 Triton –Back –Detroit 2006.

Ford F250 2004 Crew Cab –Back –Detroit 2004.

Ford F250 XL Super Duty –Back –Chicago 2001.

Ford F350 Diesel V8 –Open door –Detroit 2002.

Ford F350 Mighty –Back –New York 2002.

Ford F350 Super crewzer –Back –Detroit 2000.

Ford Ranger XLT –198 –Detroit 2000.

* cited by examiner

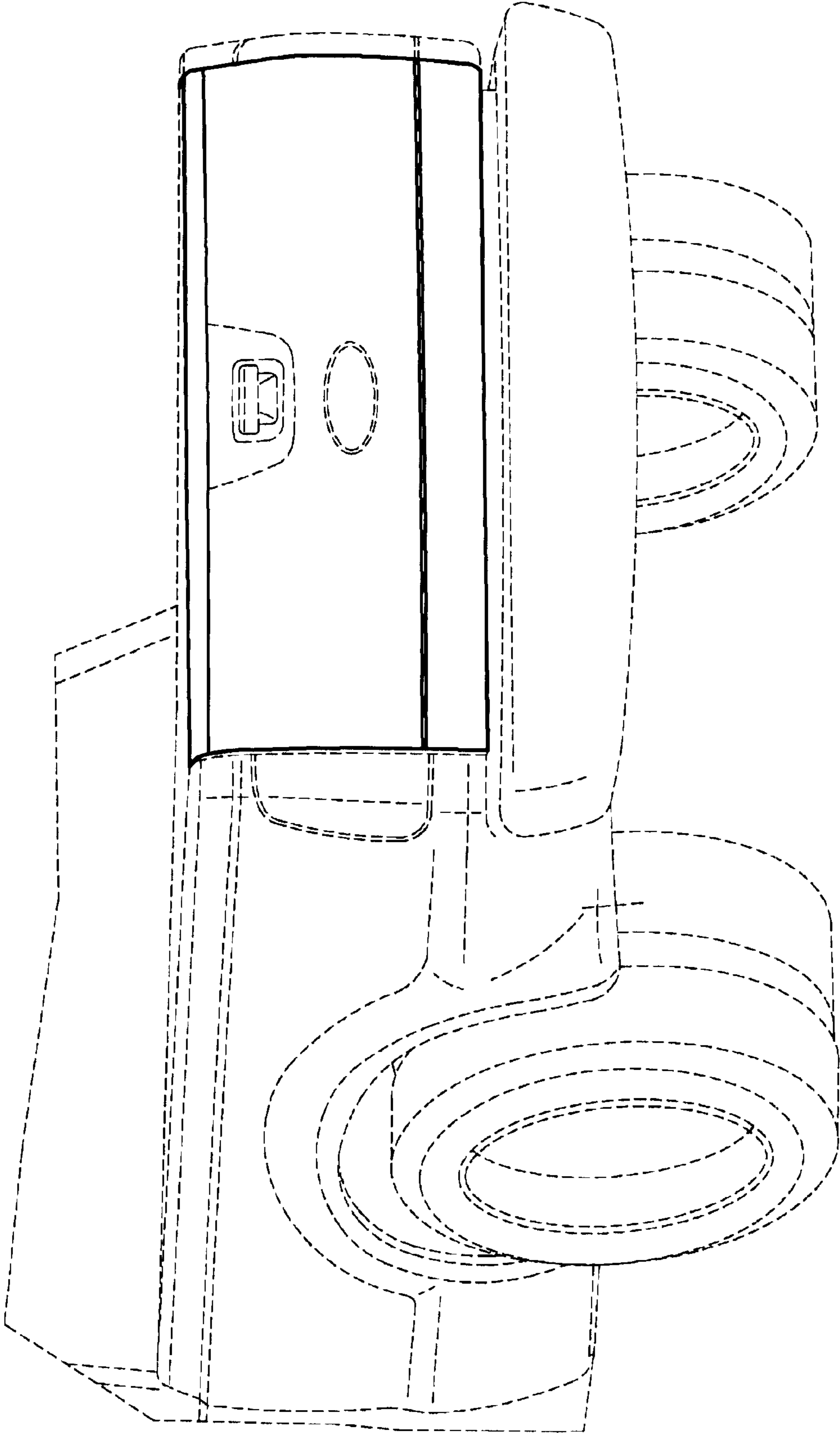

FIG - 1

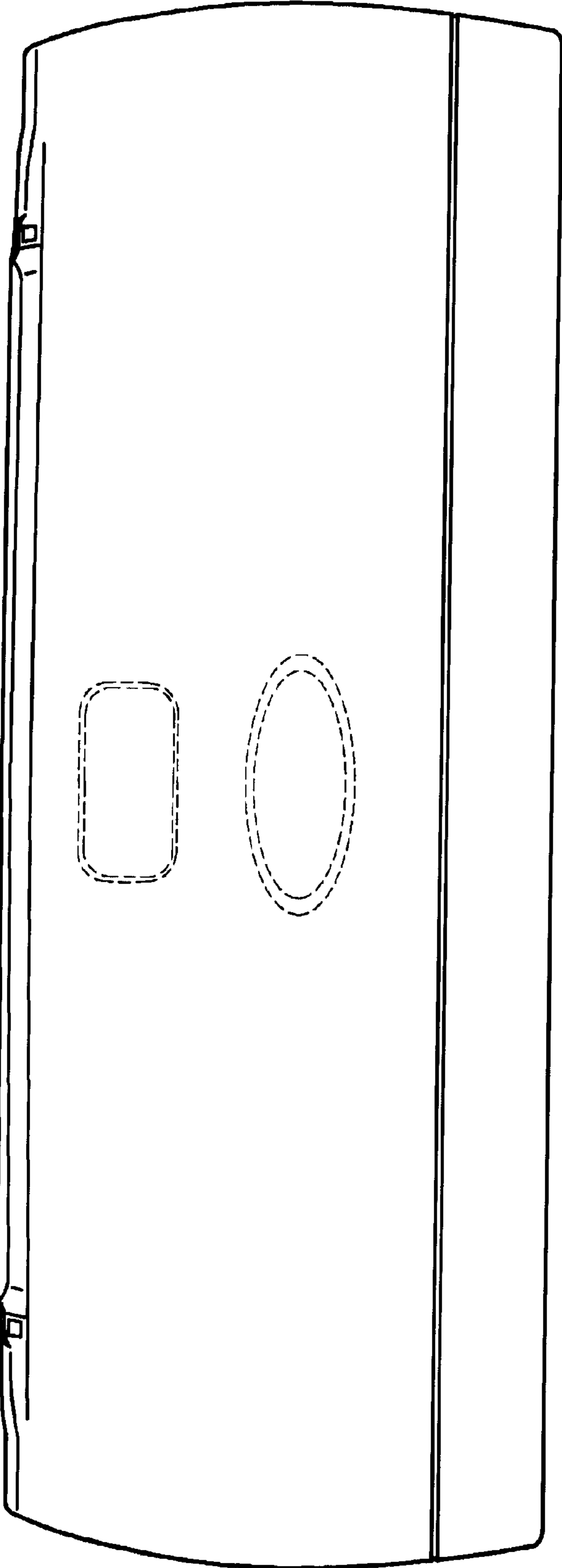

FIG - 2

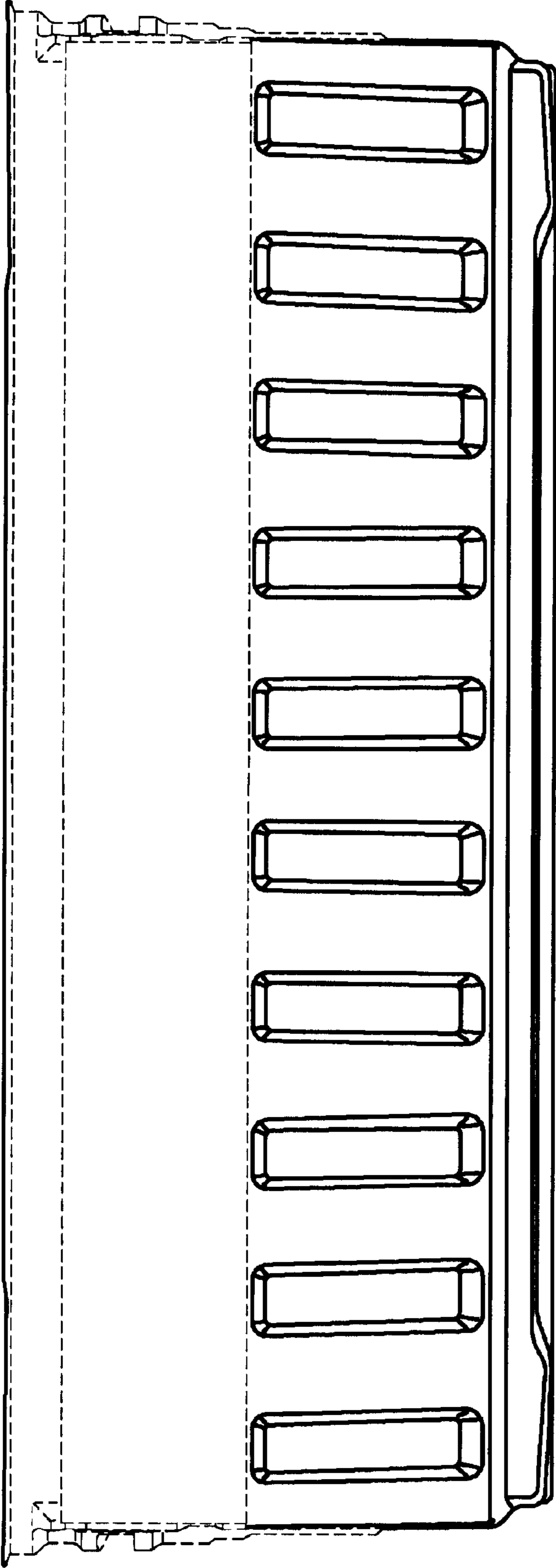

FIG - 3



FIG - 4

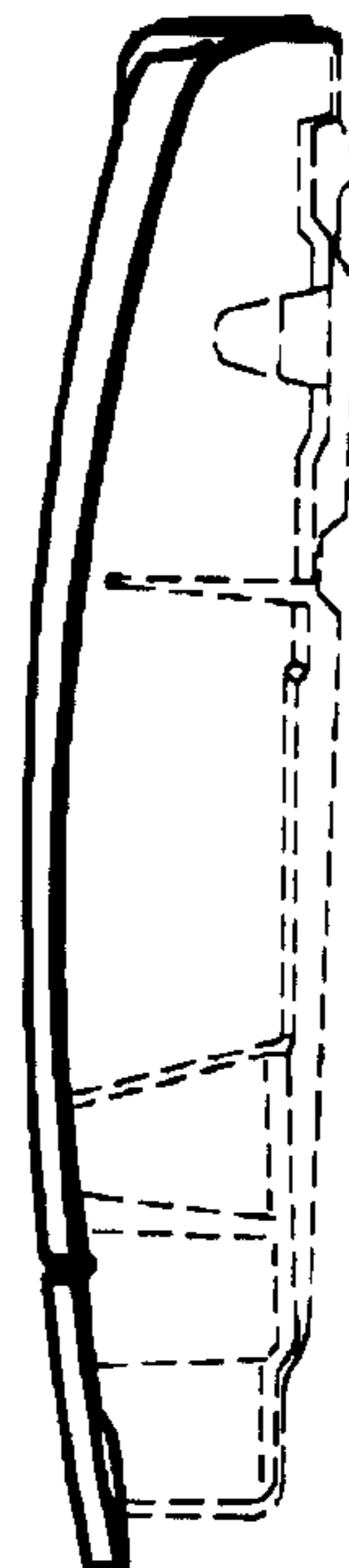

FIG - 5

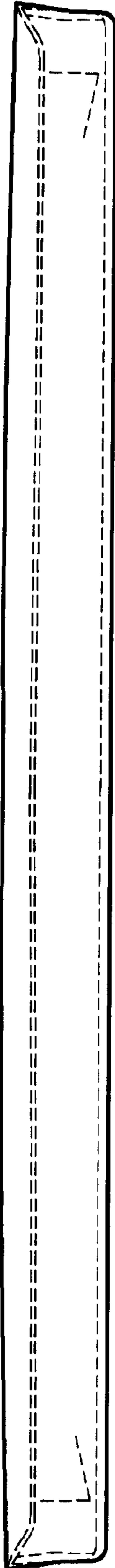

FIG - 6

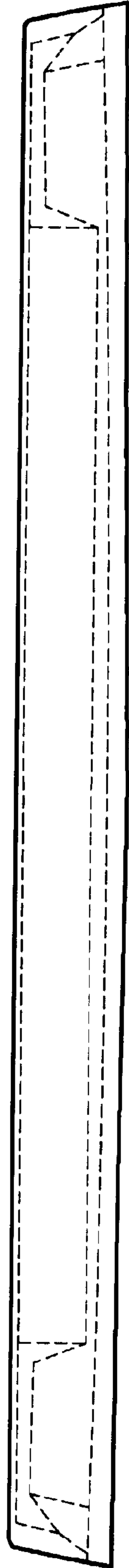

FIG-7