



US00D556002S

(12) **United States Design Patent** (10) **Patent No.:** **US D556,002 S**
Ino (45) **Date of Patent:** **** Nov. 27, 2007**

(54) **ELECTRIC IMPACT DRIVER BODY**

D533,422 S * 12/2006 Ino et al. D8/68
D533,423 S * 12/2006 Ino et al. D8/68
D535,536 S * 1/2007 Ghode et al. D8/68

(75) Inventor: **Tomoaki Ino**, Hikone (JP)

(Continued)

(73) Assignee: **Matsushita Electric Works, Ltd.**,
Osaka (JP)

FOREIGN PATENT DOCUMENTS

(**) Term: **14 Years**

GB 3003854 S * 5/2002

(21) Appl. No.: **29/285,396**

OTHER PUBLICATIONS

(22) Filed: **Mar. 28, 2007**

Japanese Design Publication No. 1187790 dated Oct. 20, 2003, 5 pages.

(30) **Foreign Application Priority Data**

Primary Examiner—T. Chase Nelson

Oct. 24, 2006 (JP) 2006-029037

(74) *Attorney, Agent, or Firm*—Osha Liang LLP

(51) **LOC (8) Cl.** **08-05**

(57) **CLAIM**

(52) **U.S. Cl.** **D8/68**

The ornamental design for an electric impact driver body, as shown and described.

(58) **Field of Classification Search** D8/14.1,
D8/61-70; 81/57.11, 429, 454-456, 469,
81/489; 173/13, 104, 114, 168-171, 178,
173/201, 211, 213, 217; 408/20, 124, 125,
408/234, 241 R; 451/358; 310/50; 227/8,
227/113, 114, 120, 130, 136, 142

DESCRIPTION

See application file for complete search history.

FIG. 1 is a front perspective view of the design according to the invention.

(56) **References Cited**

U.S. PATENT DOCUMENTS

D392,863 S * 3/1998 Sugimoto et al. D8/68
6,227,308 B1 * 5/2001 Ghode et al. 173/211
D462,594 S * 9/2002 Flickinger D8/68
D477,205 S * 7/2003 Sakai et al. D8/68
D484,384 S * 12/2003 Ghode et al. D8/68
D494,435 S * 8/2004 Hayakawa et al. D8/68
6,860,342 B1 * 3/2005 Wu et al. 173/170
6,883,621 B1 * 4/2005 Lin 173/217
D505,055 S * 5/2005 Nagasaka et al. D8/68
D508,642 S * 8/2005 Kokawa et al. D8/68
D512,891 S * 12/2005 Aglassinger D8/68
D514,910 S * 2/2006 Nagasaka et al. D8/68
D515,375 S * 2/2006 Tsang et al. D8/68
D519,808 S * 5/2006 Otsuka et al. D8/68
D525,099 S * 7/2006 Nagasaka et al. D8/68
D525,100 S * 7/2006 Huang et al. D8/68

FIG. 2 is a back perspective view of the design according to the invention.

FIG. 3 is a front view of the design according to the invention.

FIG. 4 is a rear view of the design according to the invention.

FIG. 5 is a left view of the design according to the invention.

FIG. 6 is a right view of the design according to the invention.

FIG. 7 is a top view of the design according to the invention.

FIG. 8 is a bottom view of the design according to the invention; and,

FIG. 9 is a front perspective view of the design showing an attached battery pack in broken lines according to the invention.

The elements shown in broken lines are for illustrative purposes only and form no part of the claimed design.

1 Claim, 7 Drawing Sheets

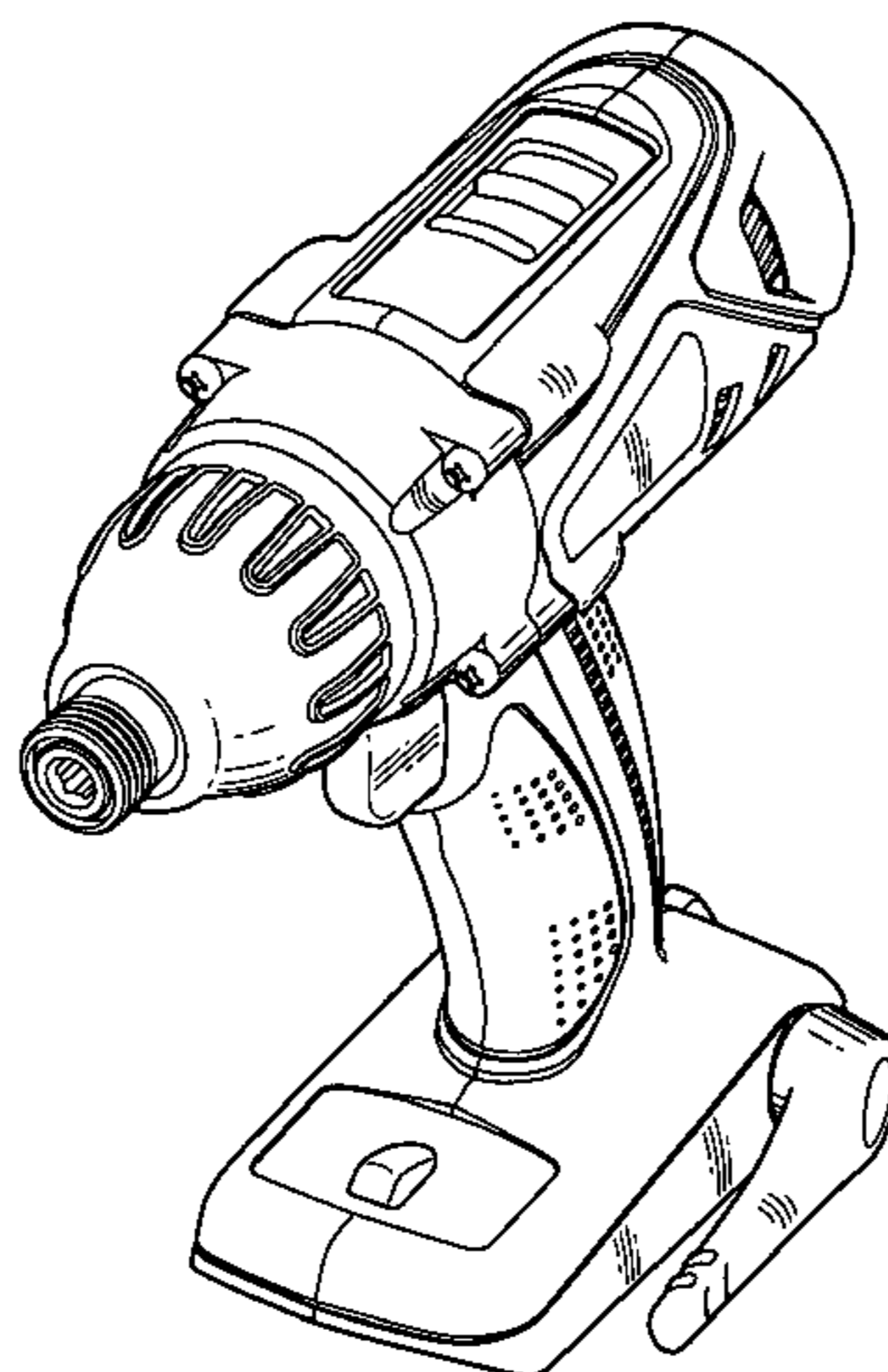

US D556,002 S

Page 2

U.S. PATENT DOCUMENTS			
7,186,117	B2 *	3/2007	Chen 173/217
2005/0121209	A1 *	6/2005	Shimizu et al. 173/217
2005/0155778	A1 *	7/2005	Ishida et al. 173/170
2006/0113100	A1 *	6/2006	Hsu et al. 173/217
2006/0175069	A1 *	8/2006	Sakakibara et al. 173/217
2007/0056760	A1 *	3/2007	Yoshimizu et al. 173/217

* cited by examiner

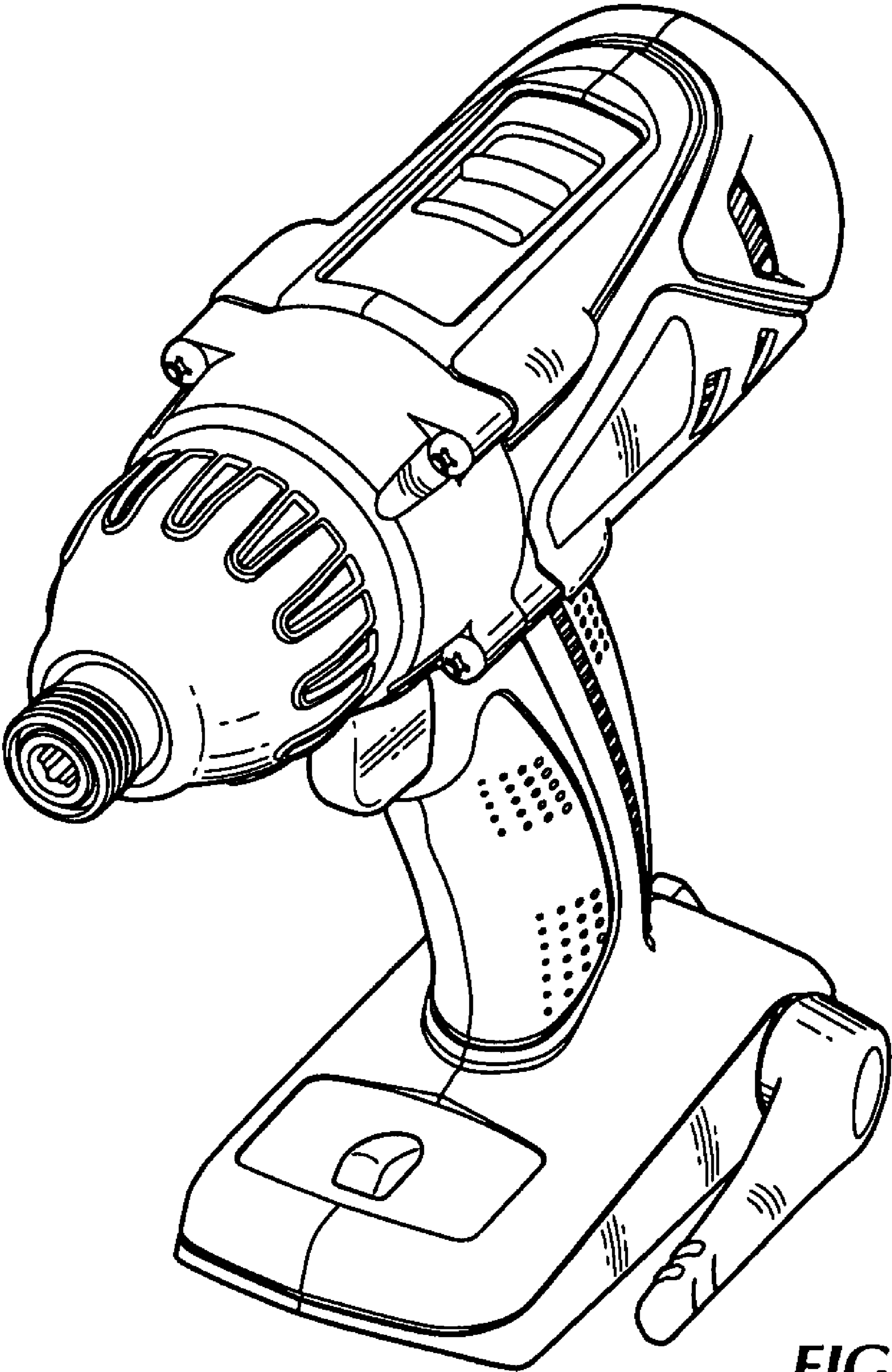

FIG. 1

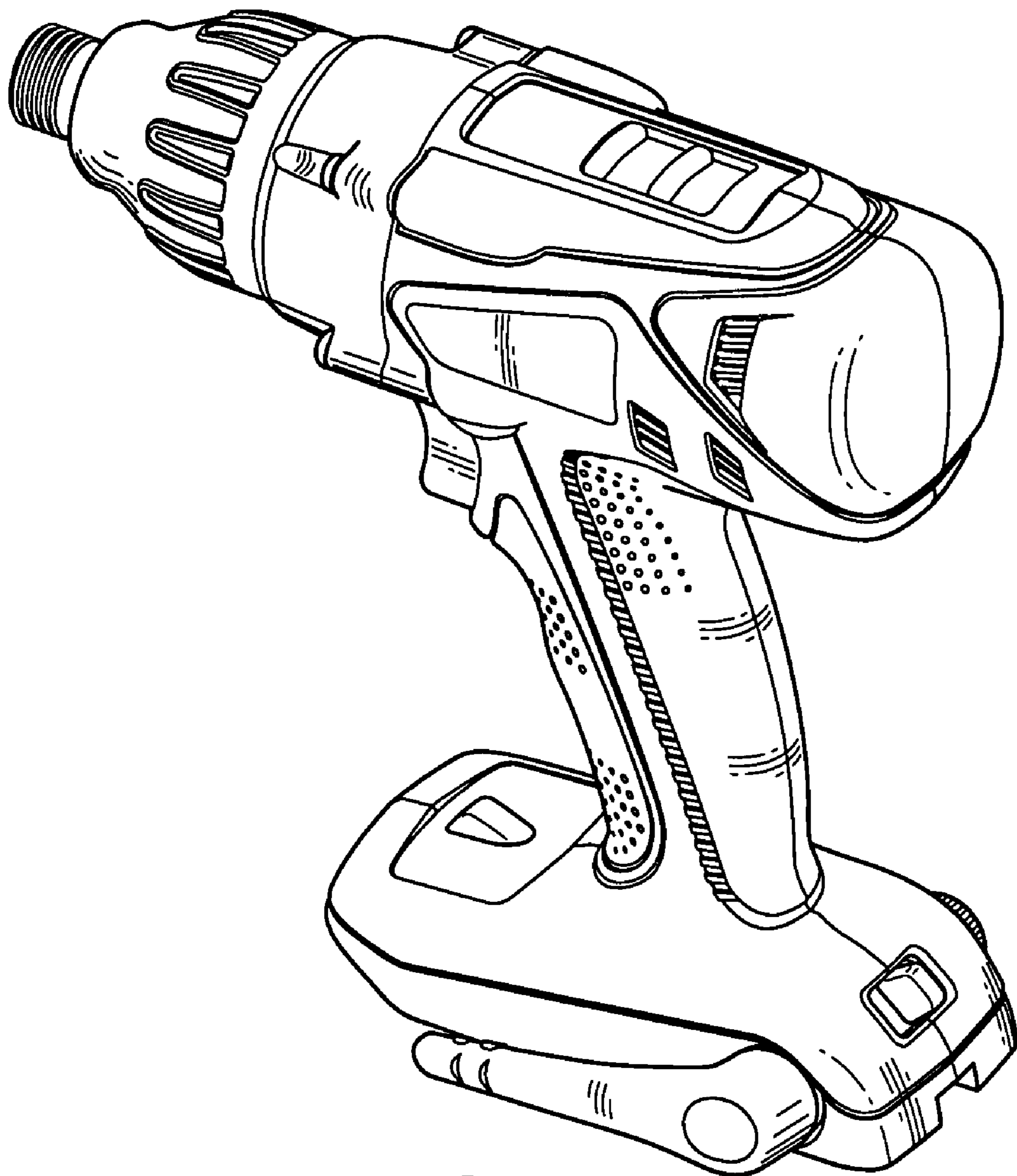

FIG. 2

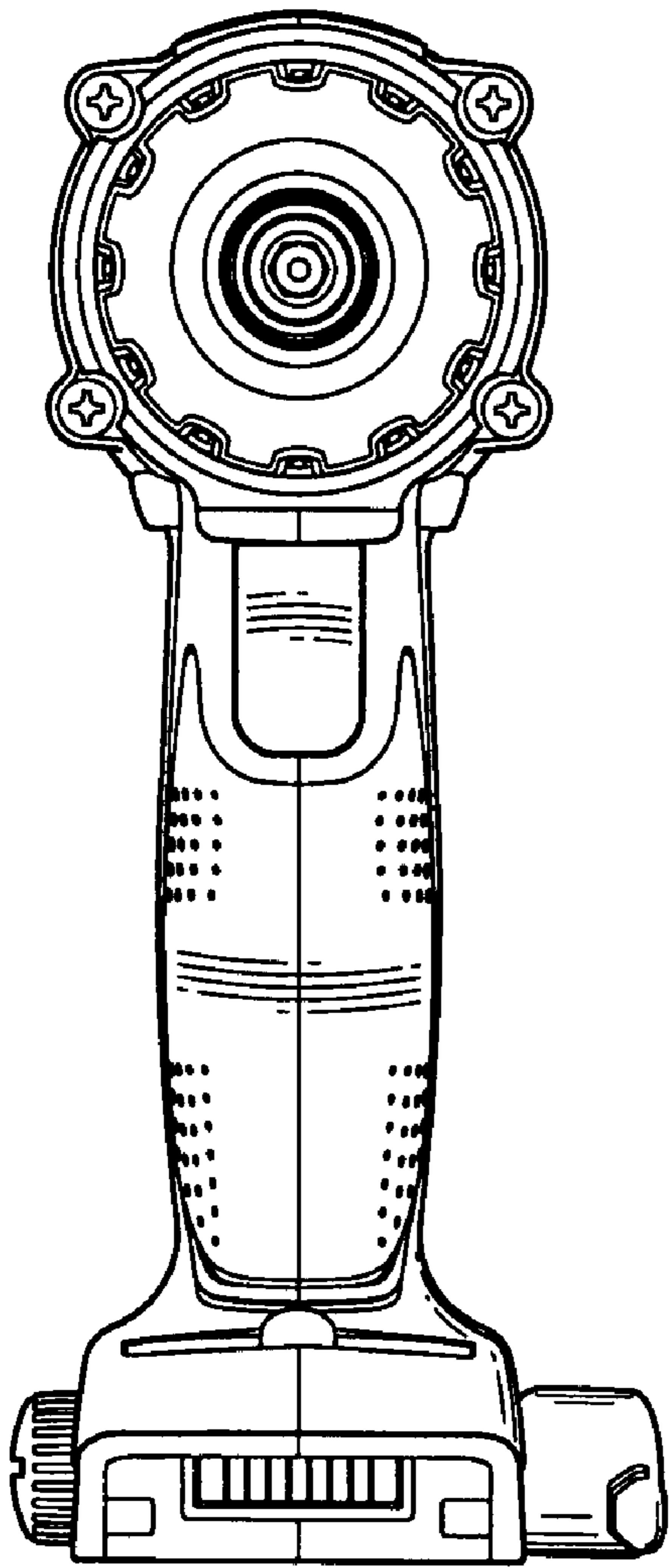

FIG. 3

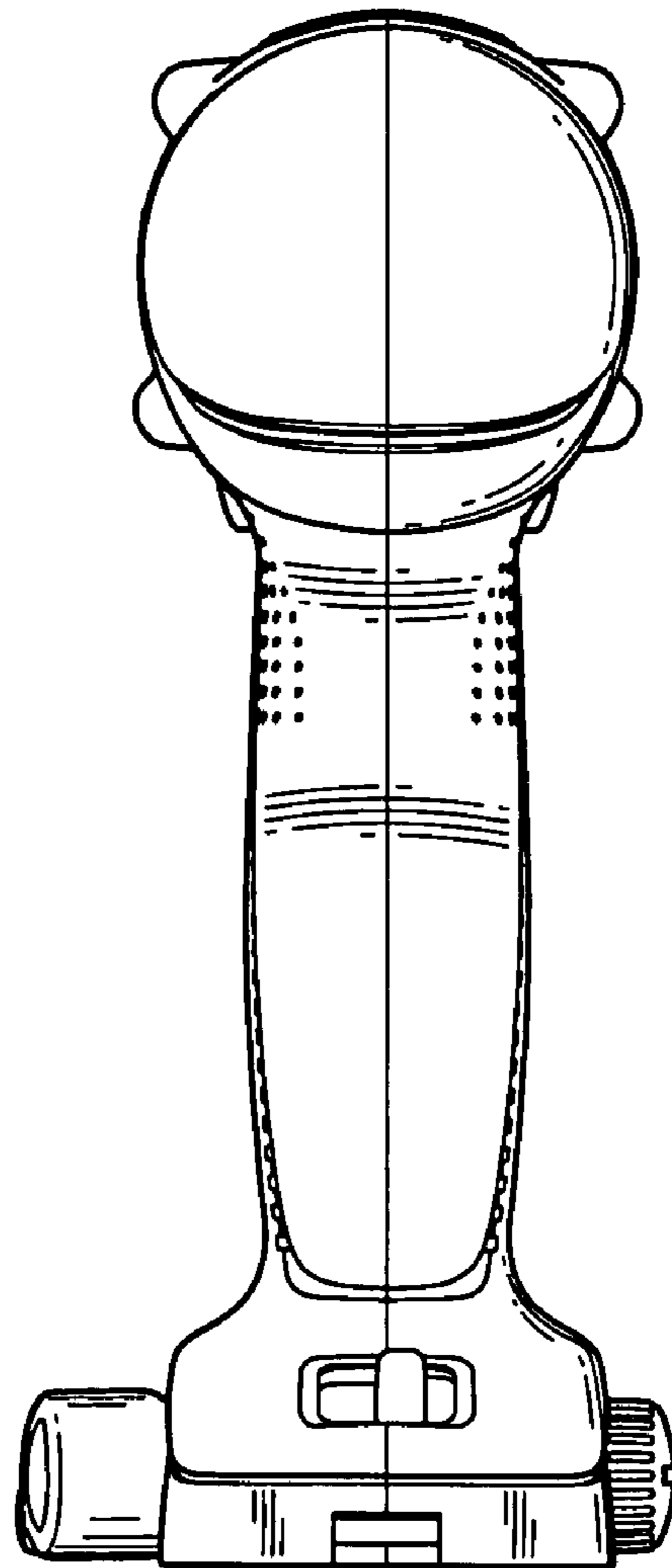

FIG. 4

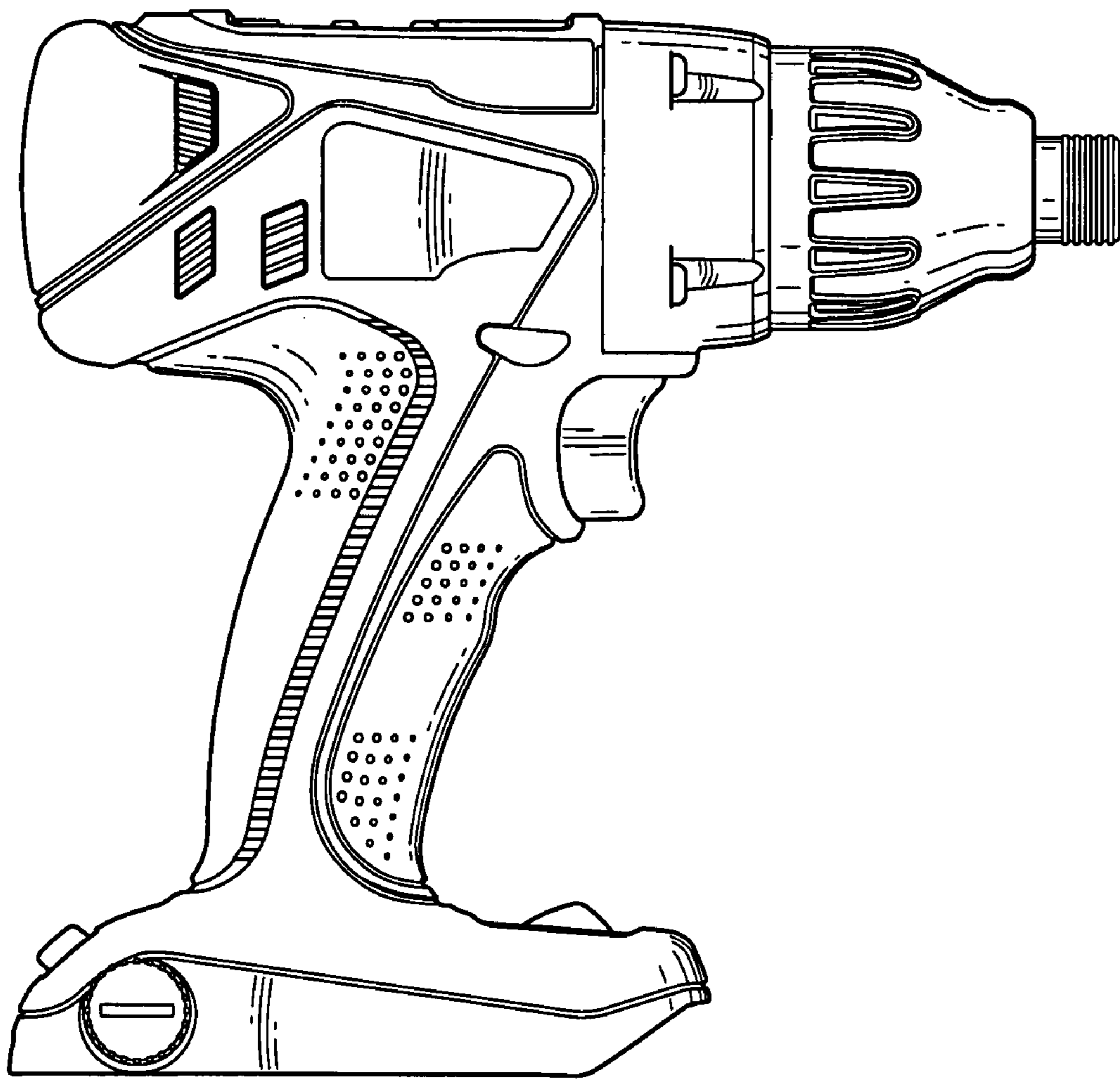

FIG. 5

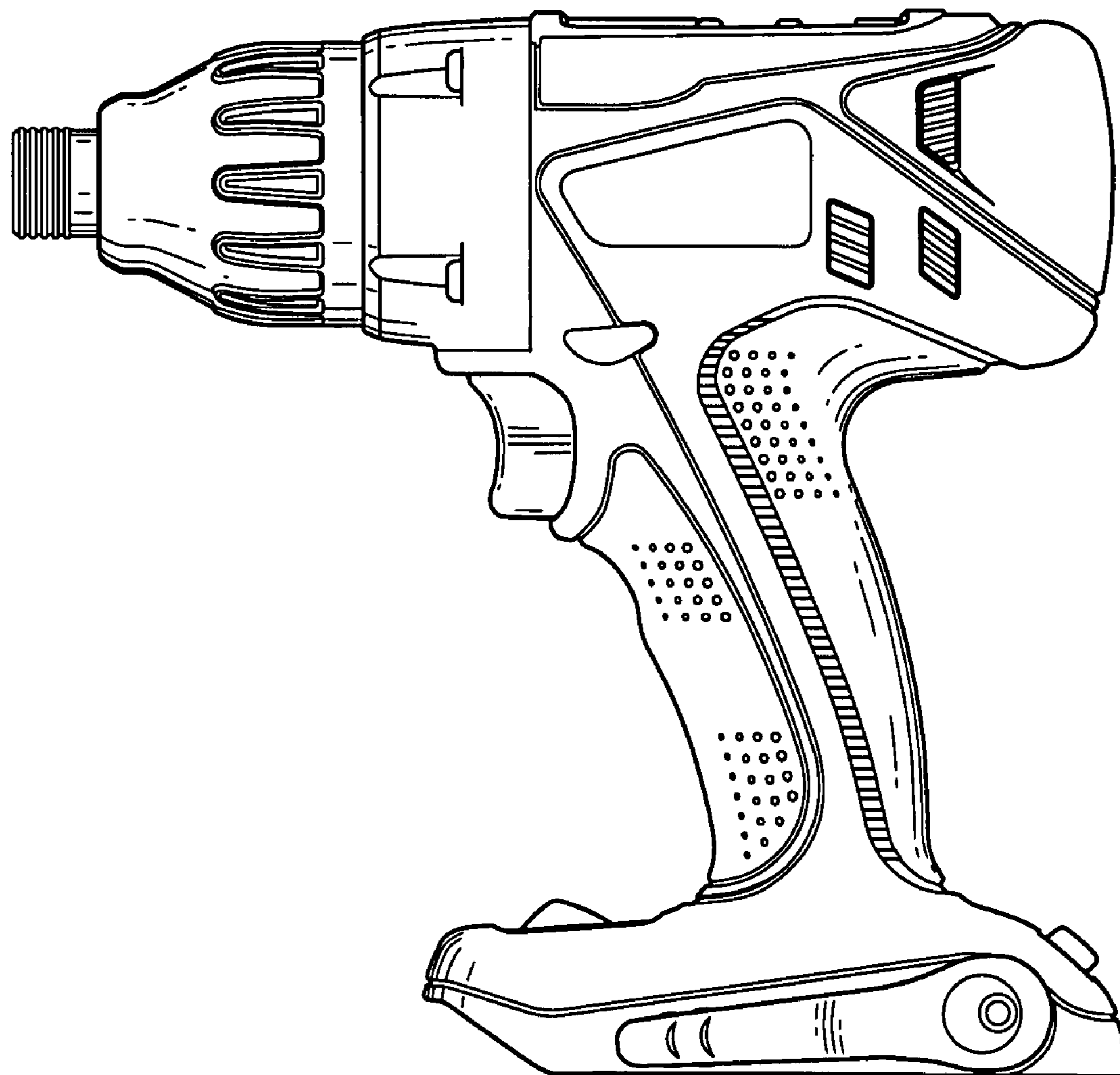

FIG. 6

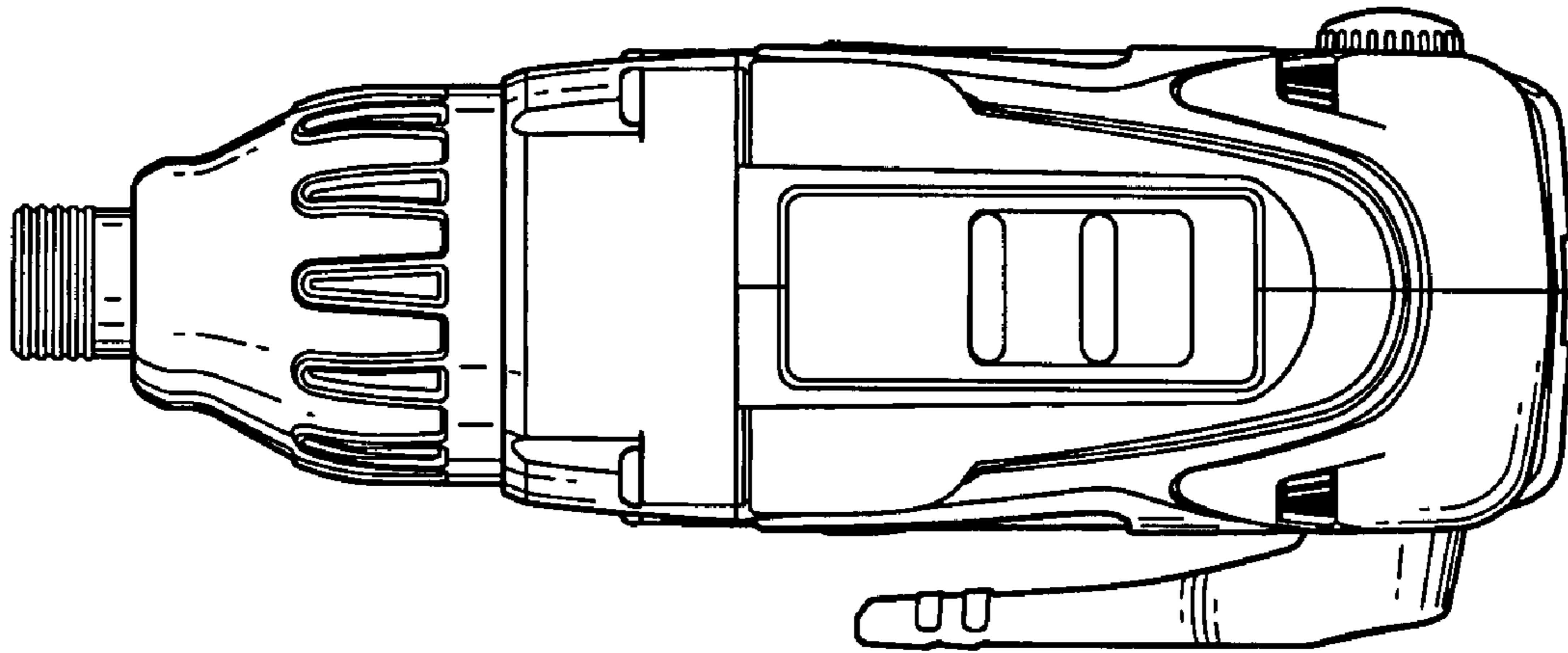

FIG. 7

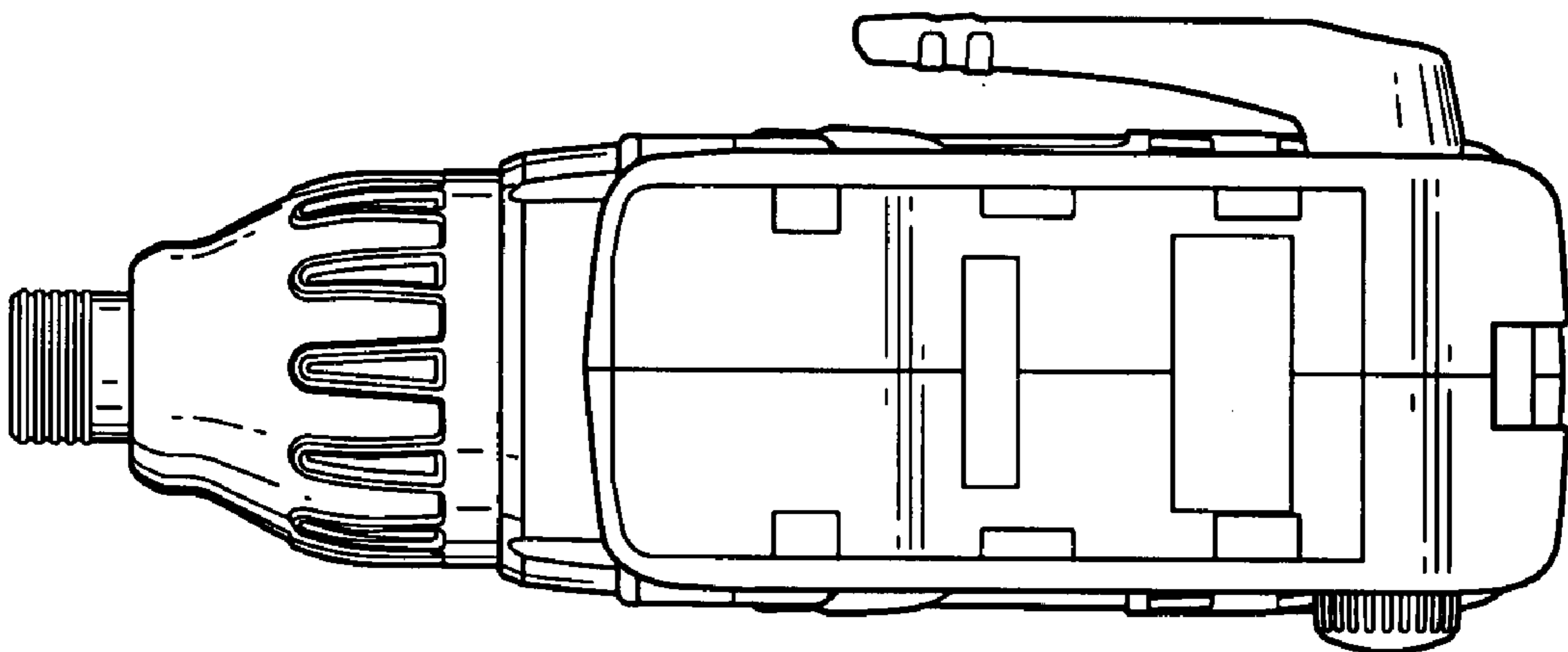

FIG. 8

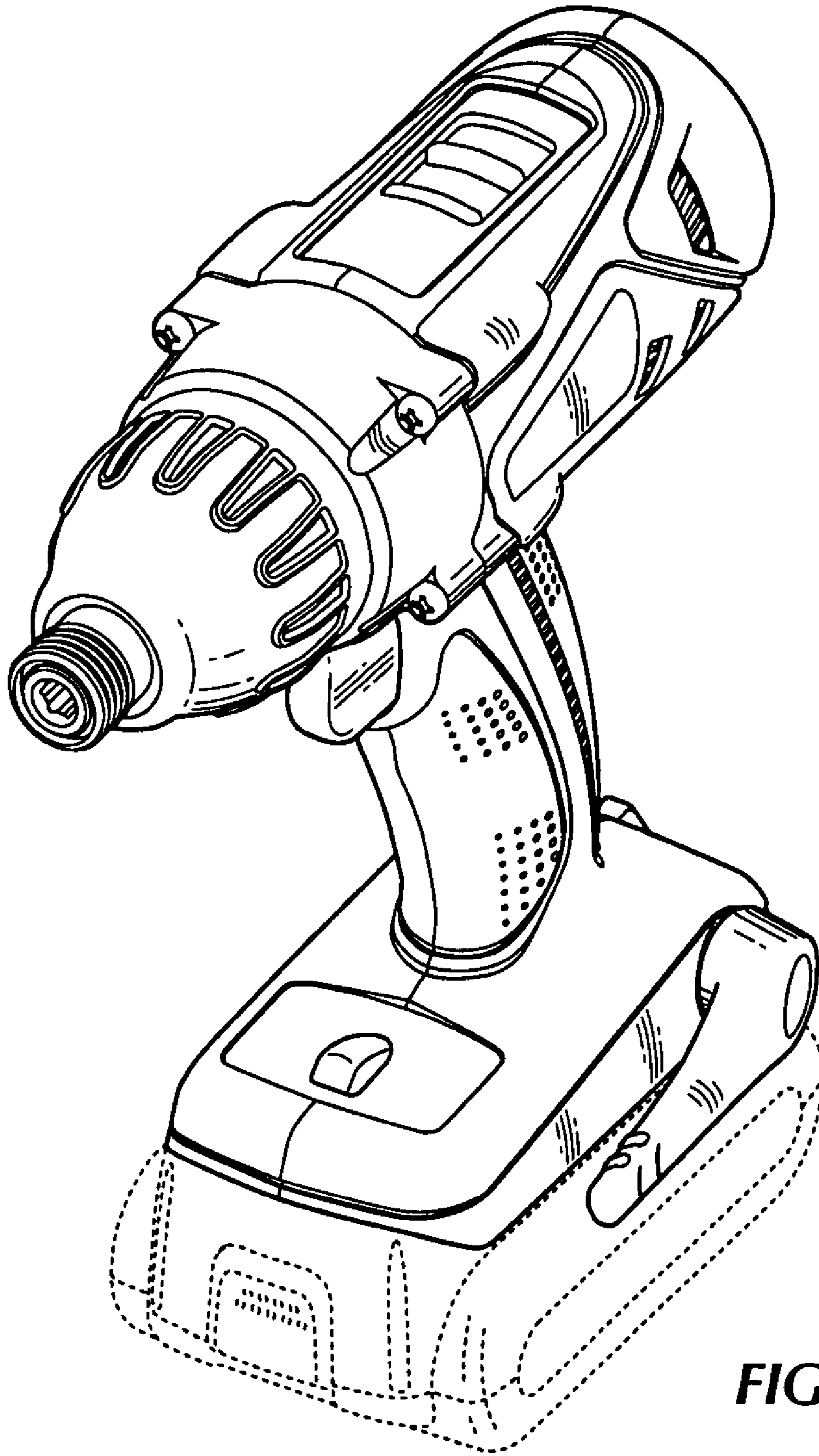

FIG. 9