



US00D555782S

(12) **United States Design Patent**
Parker et al.

(10) **Patent No.:** **US D555,782 S**

(45) **Date of Patent:** **** Nov. 20, 2007**

(54) **HIGH EFFICIENCY AIR CONDITIONER
CONDENSER TWISTED FAN BLADES AND
HUB**

6,185,954 B1 2/2001 Smiley 62/426
D510,998 S * 10/2005 Parker et al. D23/411
D539,413 S * 3/2007 Parker et al. D23/411

(75) Inventors: **Danny S. Parker**, Cocoa Beach, FL
(US); **John Sherwin**, Cocoa Beach, FL
(US); **Bart Hibbs**, Simi Valley, CA
(US)

* cited by examiner

Primary Examiner—Lisa Lichtenstein

(74) *Attorney, Agent, or Firm*—Brian S. Steinberger; Law
Offices of Brian S. Steinberger, P.A.

(73) Assignee: **Research Foundation of the
University of Central Florida, Inc.**,
Orlando, FL (US)

(57) **CLAIM**

(**) Term: **14 Years**

The ornamental design for a high efficiency air conditioner
condenser twisted fan blades and hub, as shown and
described.

(21) Appl. No.: **29/268,980**

(22) Filed: **Nov. 17, 2006**

DESCRIPTION

Related U.S. Application Data

(62) Division of application No. 29/231,433, filed on Jun.
3, 2005, now Pat. No. Des. 539,413, which is a
division of application No. 29/178,526, filed on Mar.
27, 2003, now Pat. No. Des. 510,998.

FIG. 1 is a perspective view of a high efficiency air condi-
tioner condenser twisted fan blades with hub.

FIG. 2 is a front side elevation view of the high efficiency air
conditioner condenser twisted fan blades and hub of FIG. 1.

FIG. 3 is a left side end view of the high efficiency air
conditioner condenser twisted fan blades and hub of FIG. 1.

FIG. 4 is a right side end view of the high efficiency air
conditioner condenser twisted fan blades and hub of FIG. 1.

FIG. 5 is a bottom elevation view of the high efficiency air
conditioner condenser twisted fan blades and hub of FIG. 1.

FIG. 6 is a top elevation view of the high efficiency air
conditioner condenser twisted fan blades and hub of FIG. 1.

FIG. 7 is a perspective view of a high efficiency air condi-
tioner condenser twisted fan blades with hub.

FIG. 8 is a front side elevation view of the high efficiency air
conditioner condenser twisted fan blades and hub of FIG. 7.

FIG. 9 is a left side end view of the high efficiency air
conditioner condenser twisted fan blades and hub of FIG. 7.

FIG. 10 is a right side end view of the high efficiency air
conditioner condenser twisted fan blades and hub of FIG. 7.

FIG. 11 is a bottom elevation view of the high efficiency air
conditioner condenser twisted fan blades and hub of FIG. 7.

(51) **LOC (8) Cl.** **23-04**
(52) **U.S. Cl.** **D23/411**
(58) **Field of Classification Search** D23/411,
D23/413, 370, 378, 379; 416/223 R, 238,
416/244 R; D12/214; 62/426
See application file for complete search history.

(56) **References Cited**

U.S. PATENT DOCUMENTS

2,638,757 A	5/1953	Borgerd	62/140
3,995,442 A	12/1976	Cavezza	62/259
4,470,271 A	9/1984	Draper	62/259.1
4,526,506 A	7/1985	Koger	415/98
4,971,143 A	11/1990	Hogan	165/122
4,971,520 A	11/1990	Van Houten	416/169
5,320,493 A	6/1994	Shih	416/223
5,624,234 A	4/1997	Neely	416/238
5,809,800 A	9/1998	Deal	62/507
6,129,528 A	10/2000	Bradbury	417/423

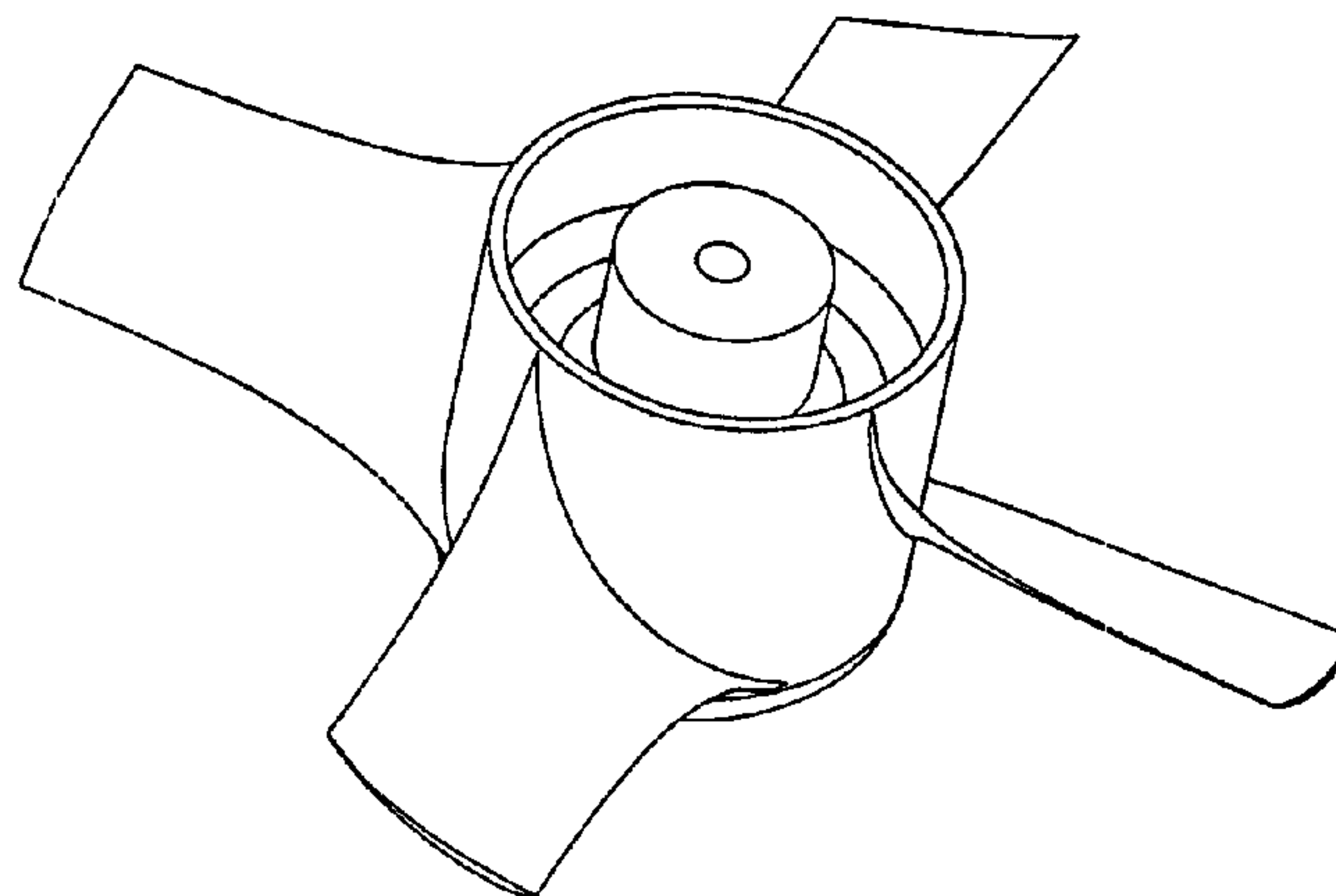

FIG. **12** is a top elevation view of the high efficiency air conditioner condenser twisted fan blades and hub of FIG. **7**.

FIG. **13** is a perspective view of a high efficiency air conditioner condenser twisted fan blades with hub.

FIG. **14** is a front side elevation view of the fifth embodiment of the high efficiency air conditioner condenser twisted fan blades and hub of FIG. **13**.

FIG. **15** is a left side end view of the fifth embodiment of the high efficiency air conditioner condenser twisted fan blades and hub of FIG. **13**.

FIG. **16** is a right side end view of the fifth embodiment of the high efficiency air conditioner condenser twisted fan blades and hub of FIG. **13**.

FIG. **17** is a bottom elevation view of the fifth embodiment of the high efficiency air conditioner condenser twisted fan blades and hub of FIG. **13**; and,

FIG. **18** is a top elevation view of the fifth embodiment of the high efficiency air conditioner condenser twisted fan blades and hub of FIG. **14**.

1 Claim, 9 Drawing Sheets

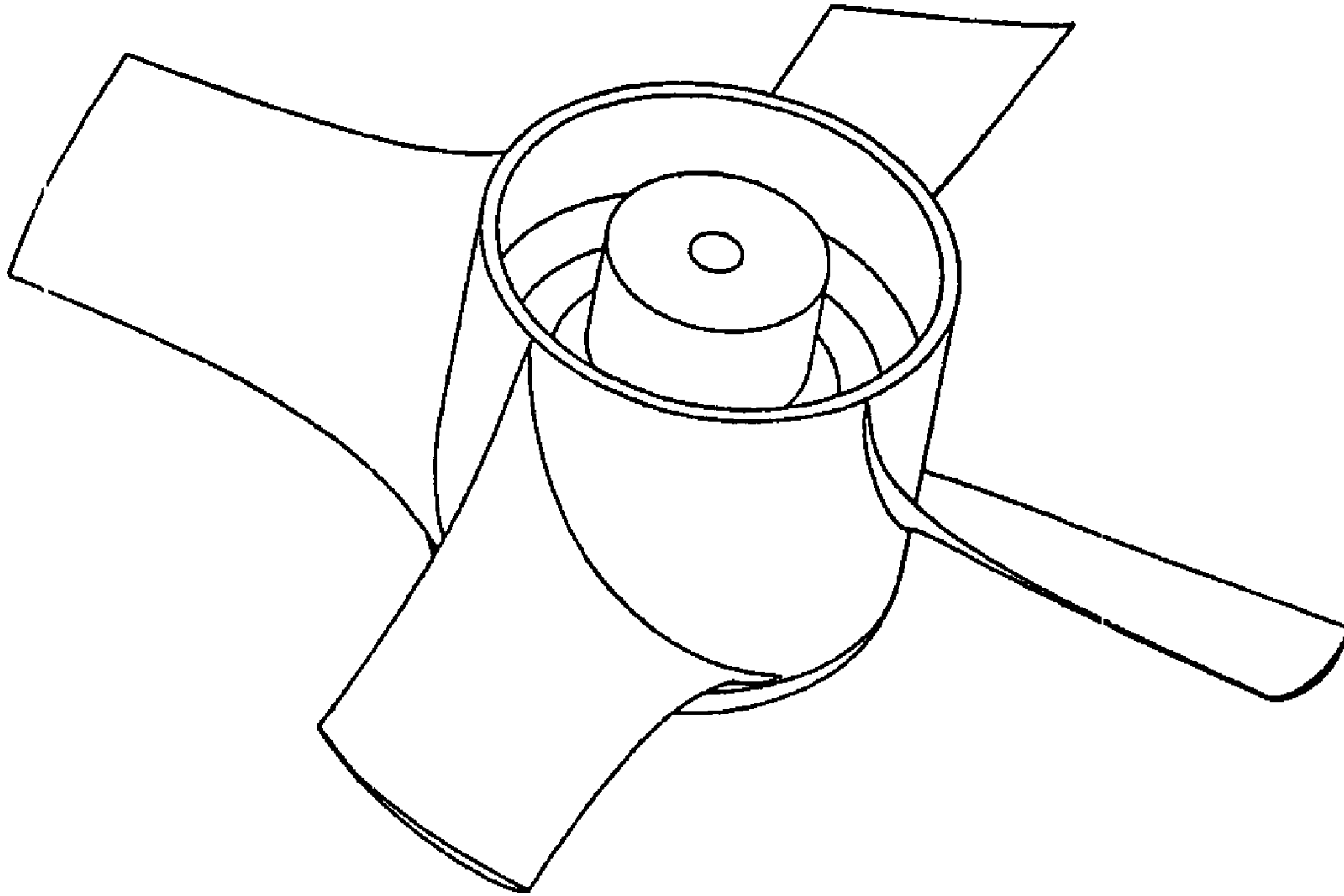

FIG. 1

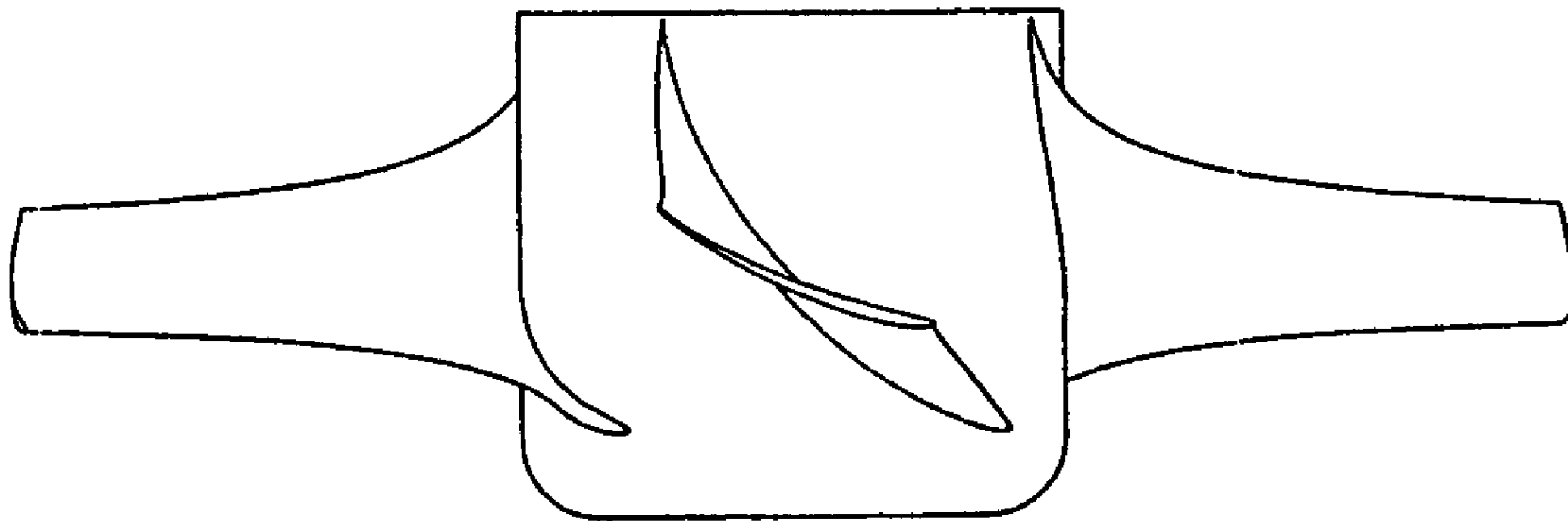

FIG. 2

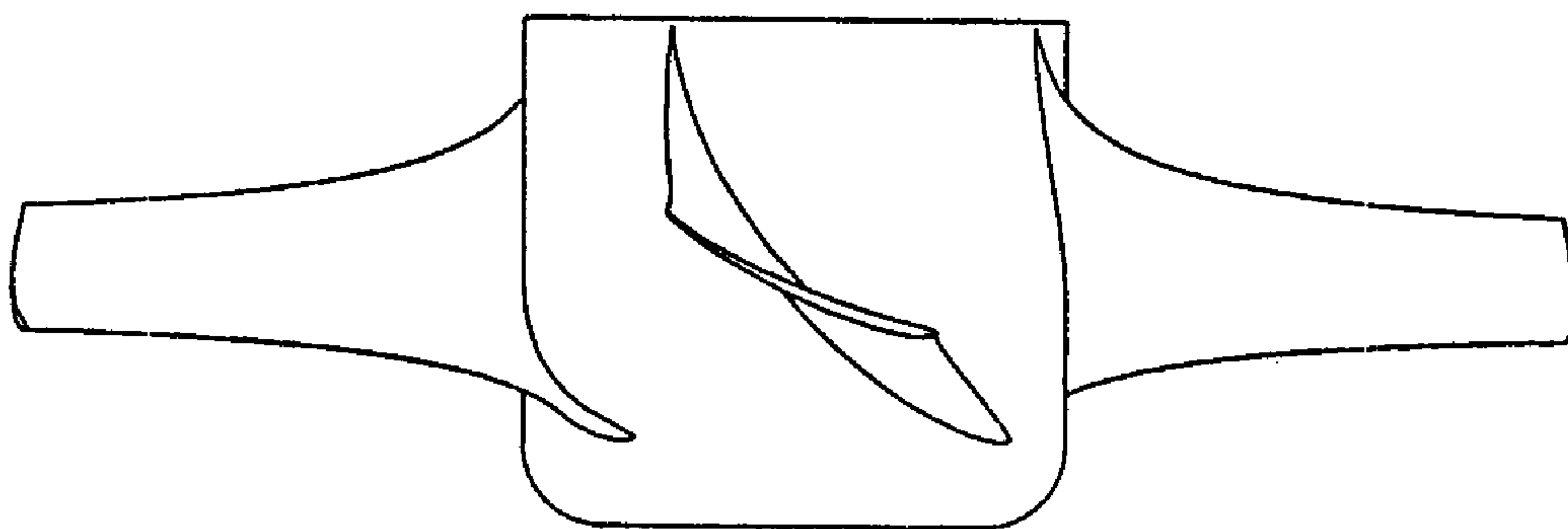

FIG. 3

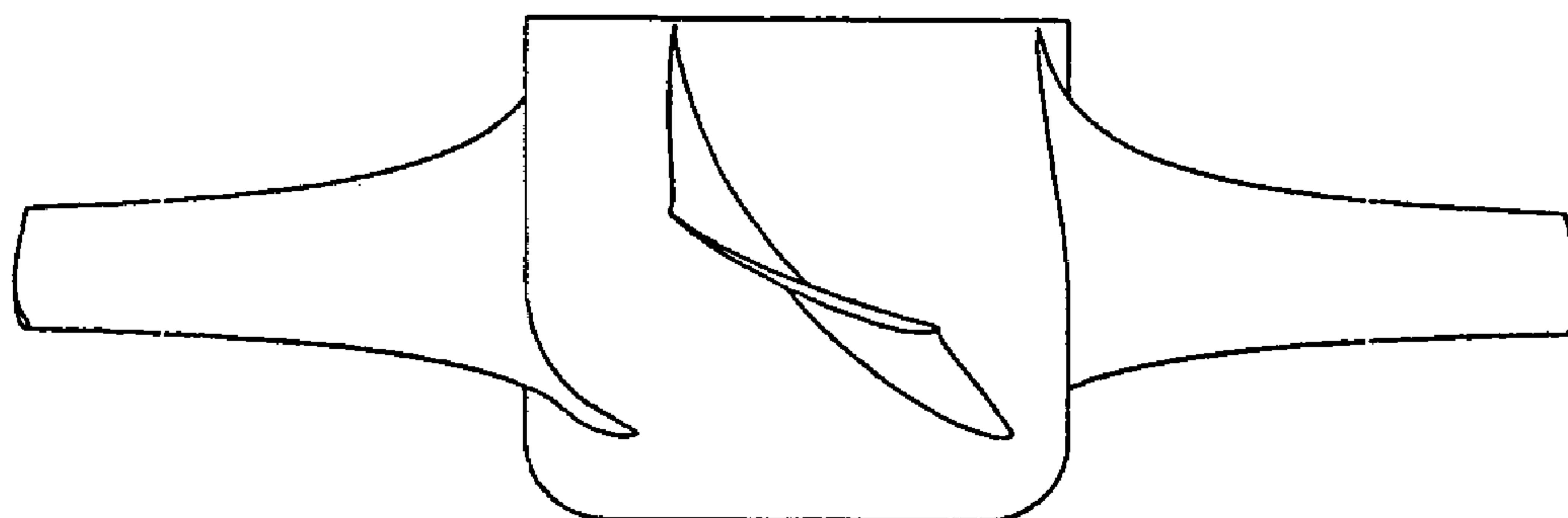

FIG. 4

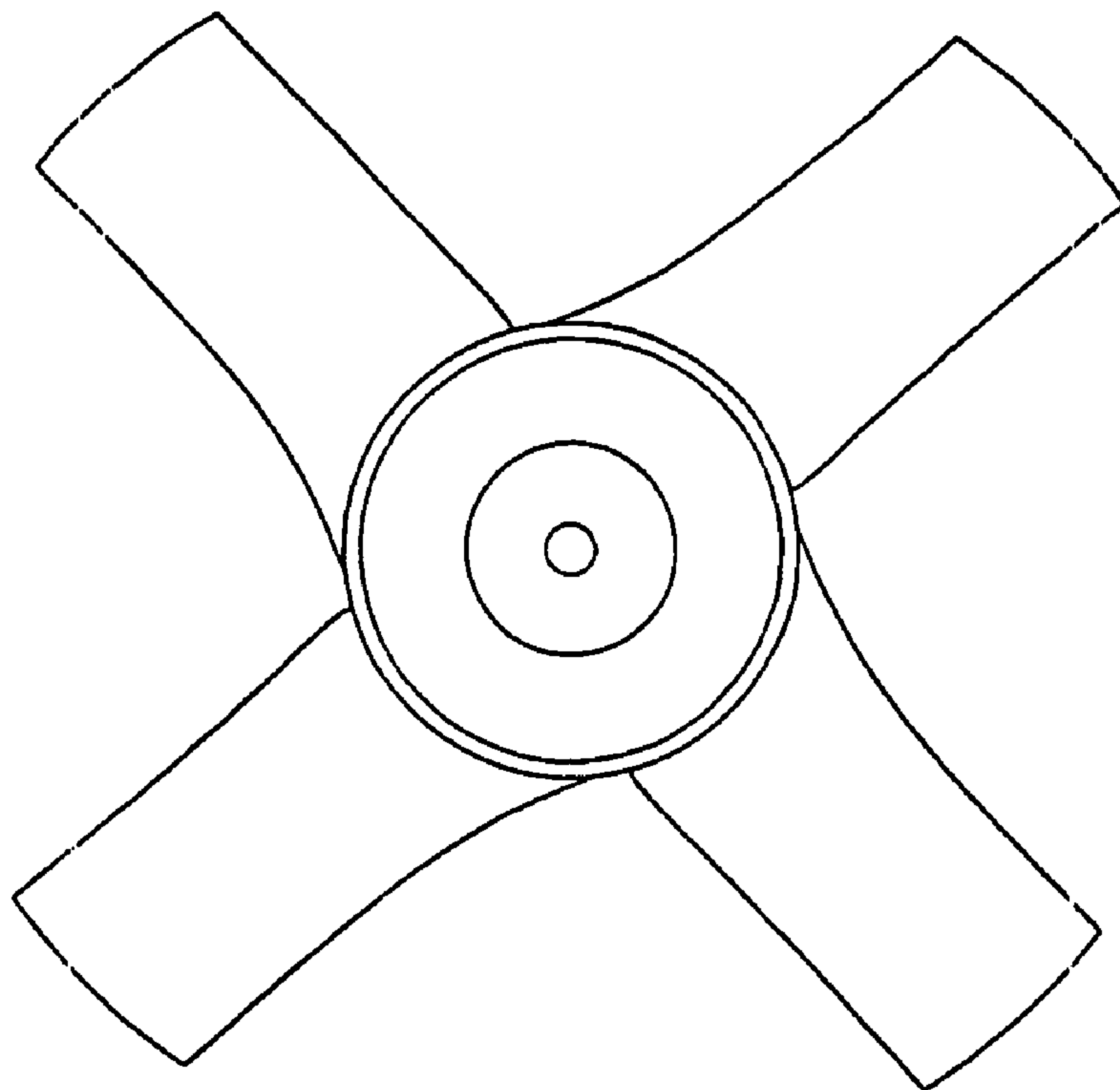

FIG. 5

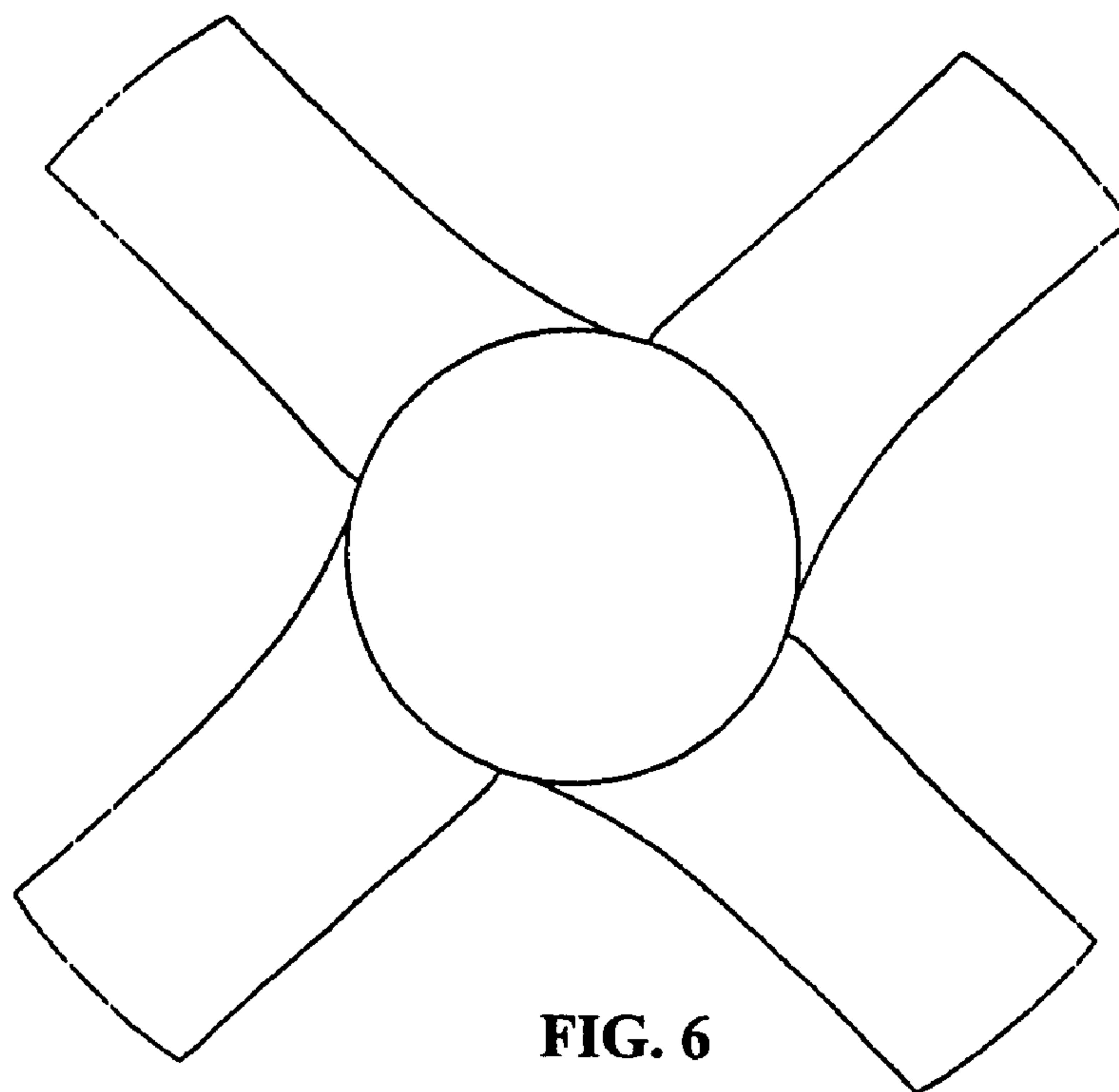

FIG. 6

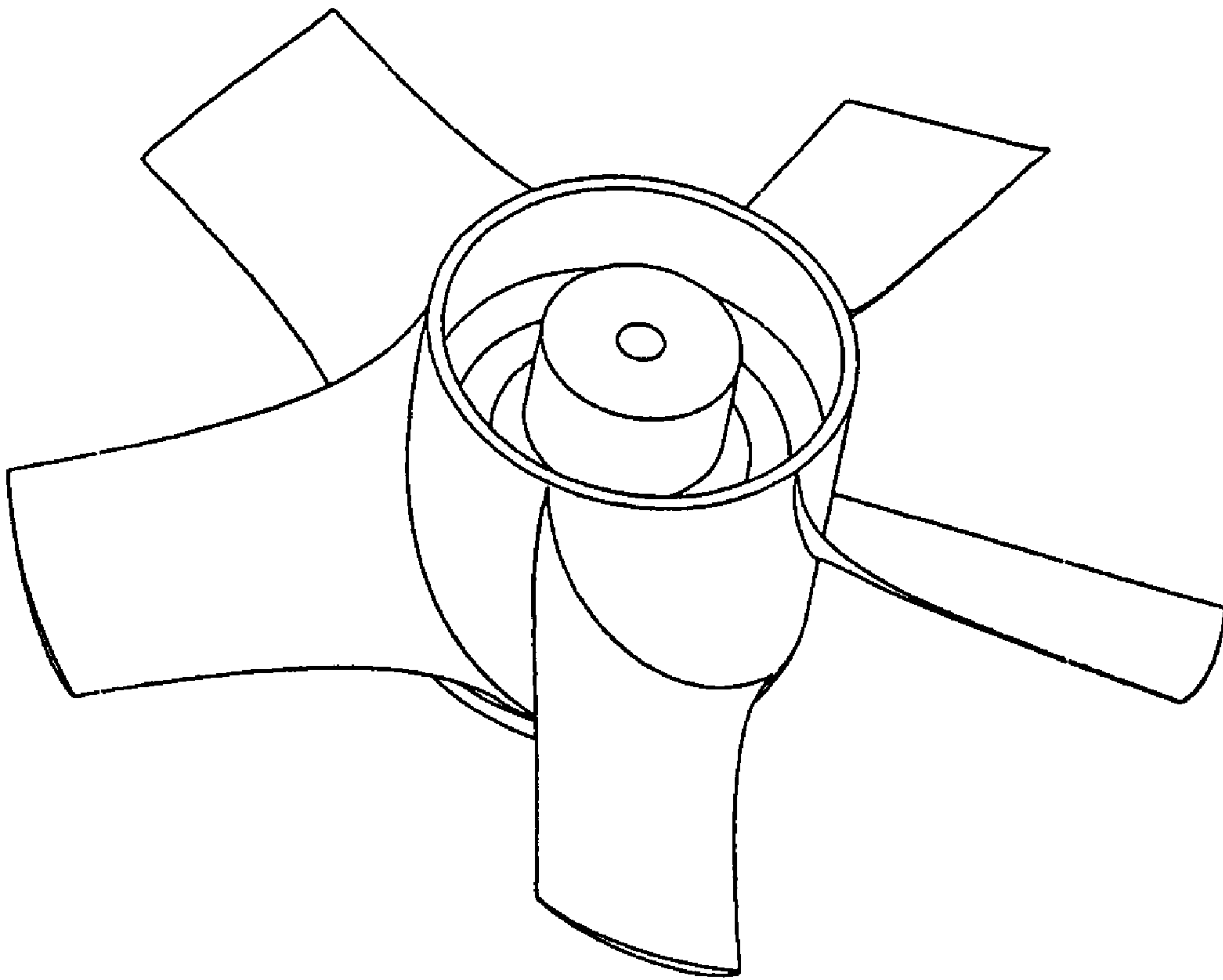

FIG. 7

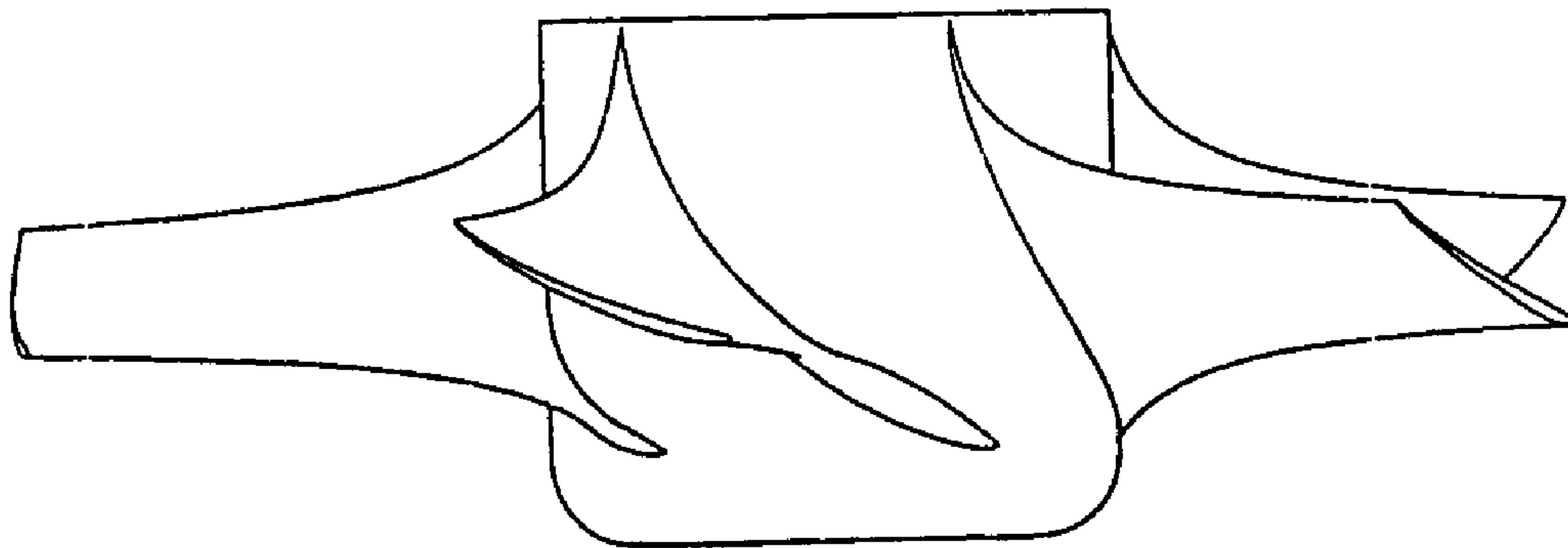

FIG. 8

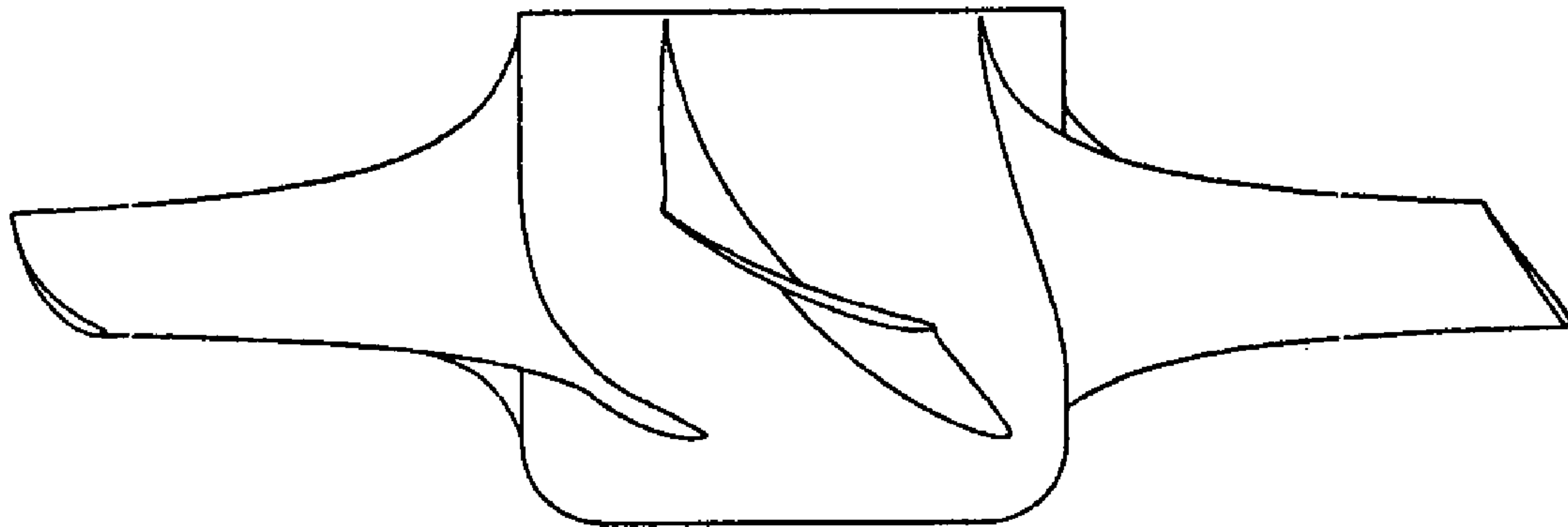

FIG. 9

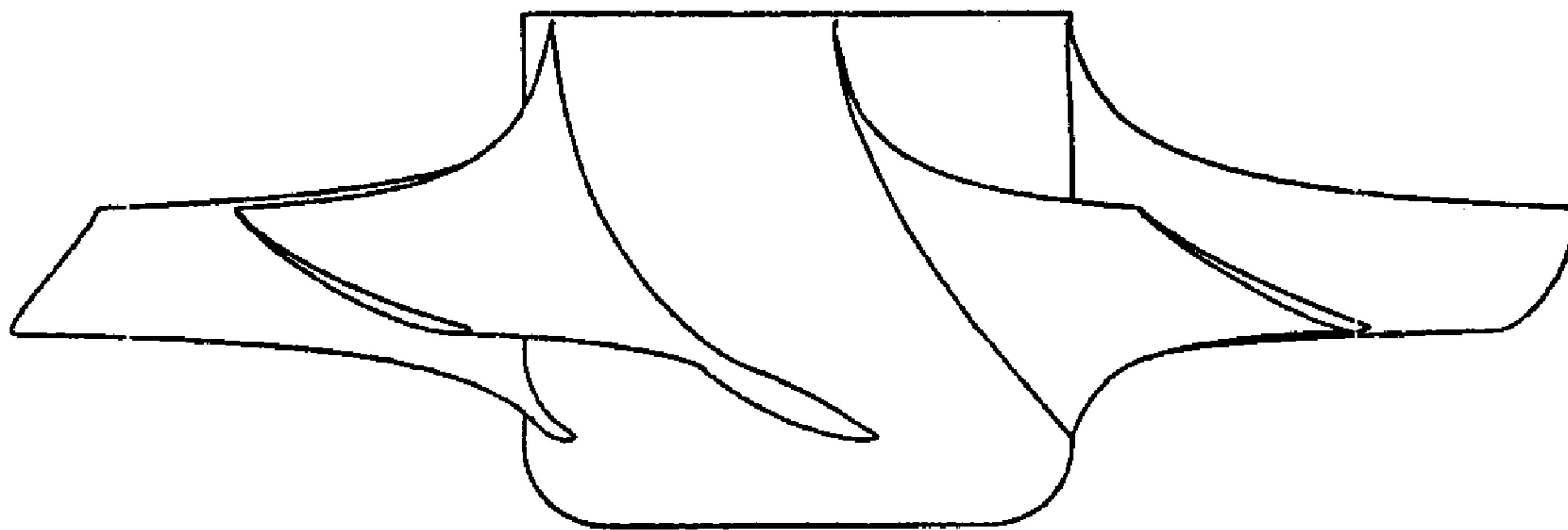

FIG. 10

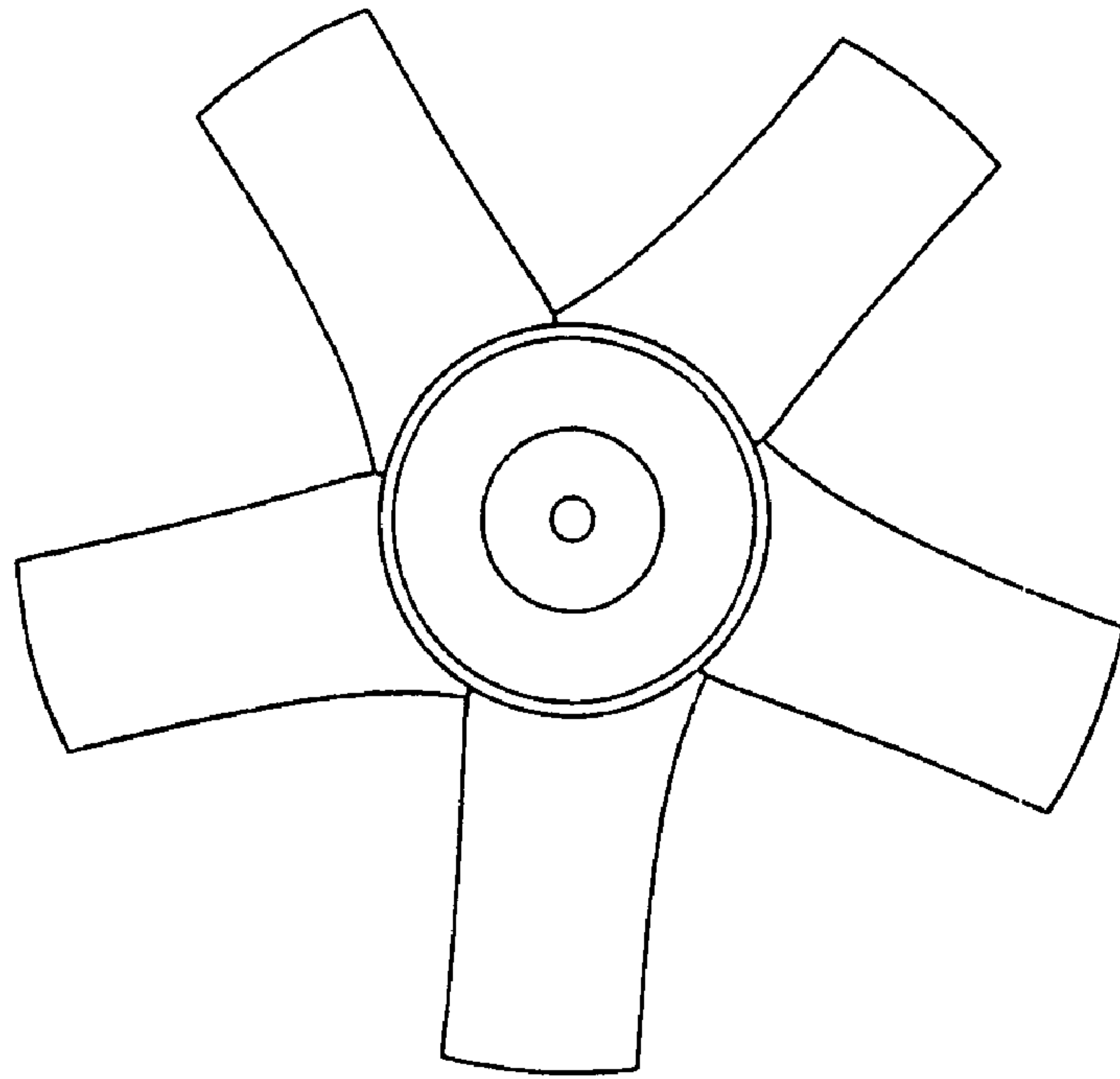

FIG. 11

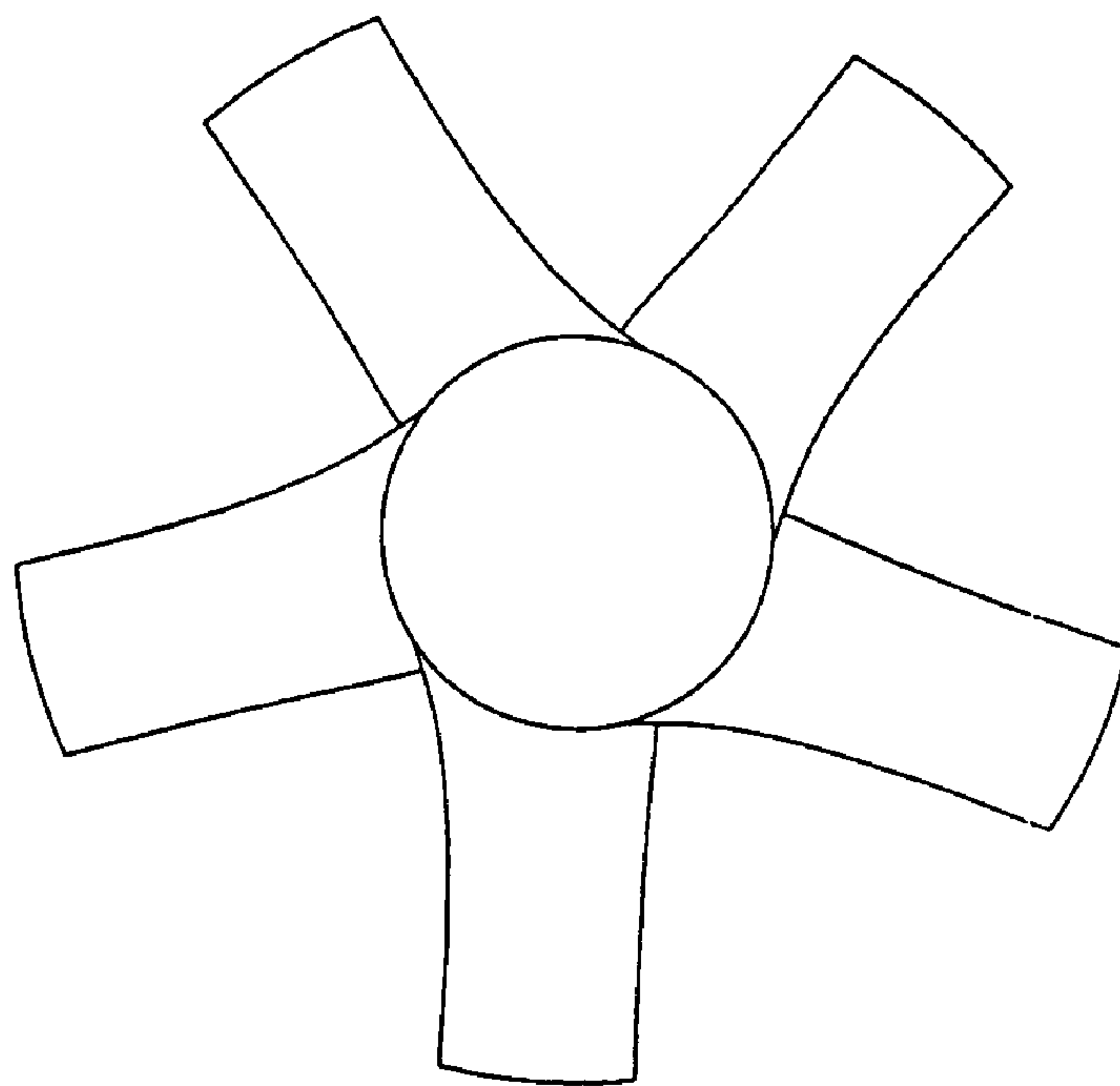

FIG. 12

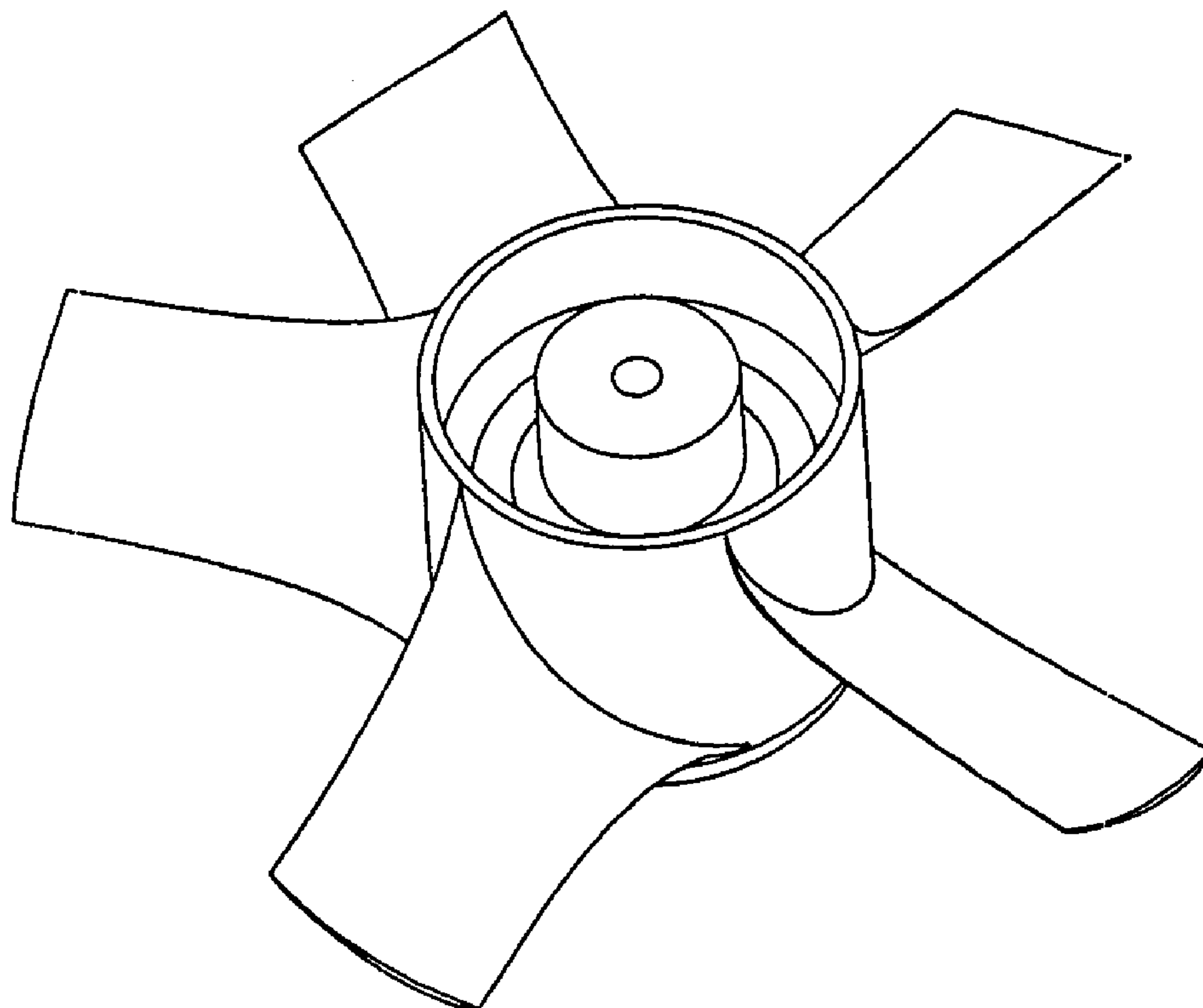

FIG. 13

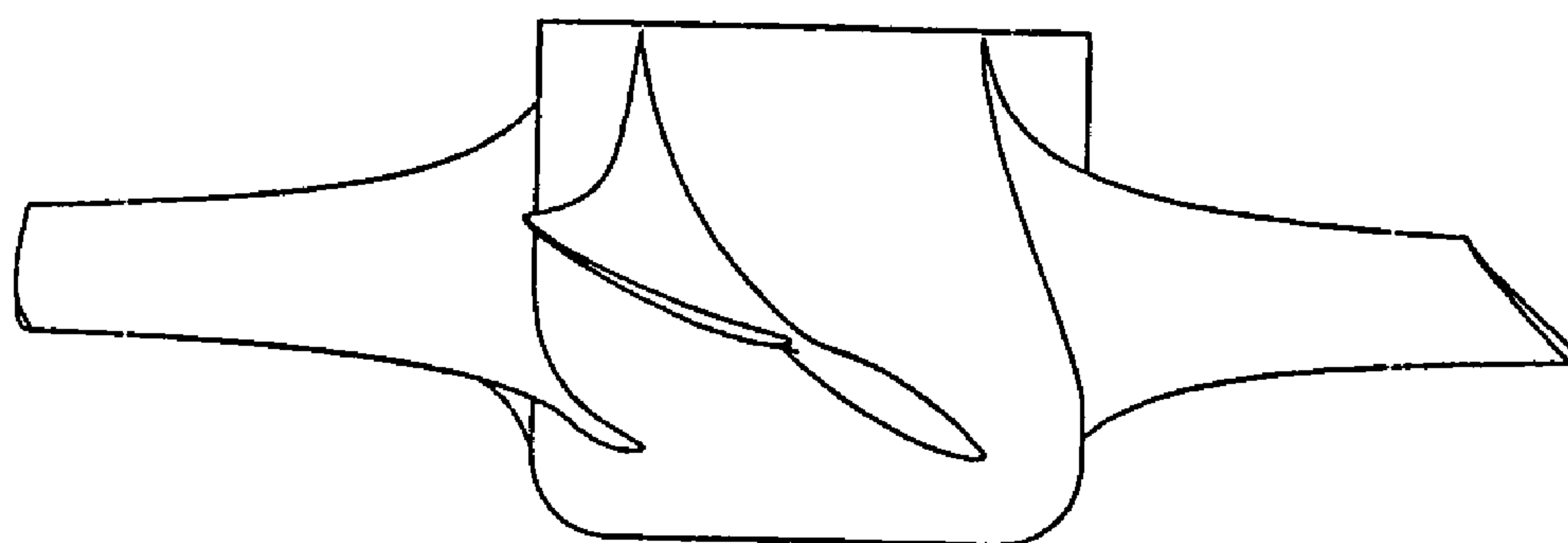

FIG. 14

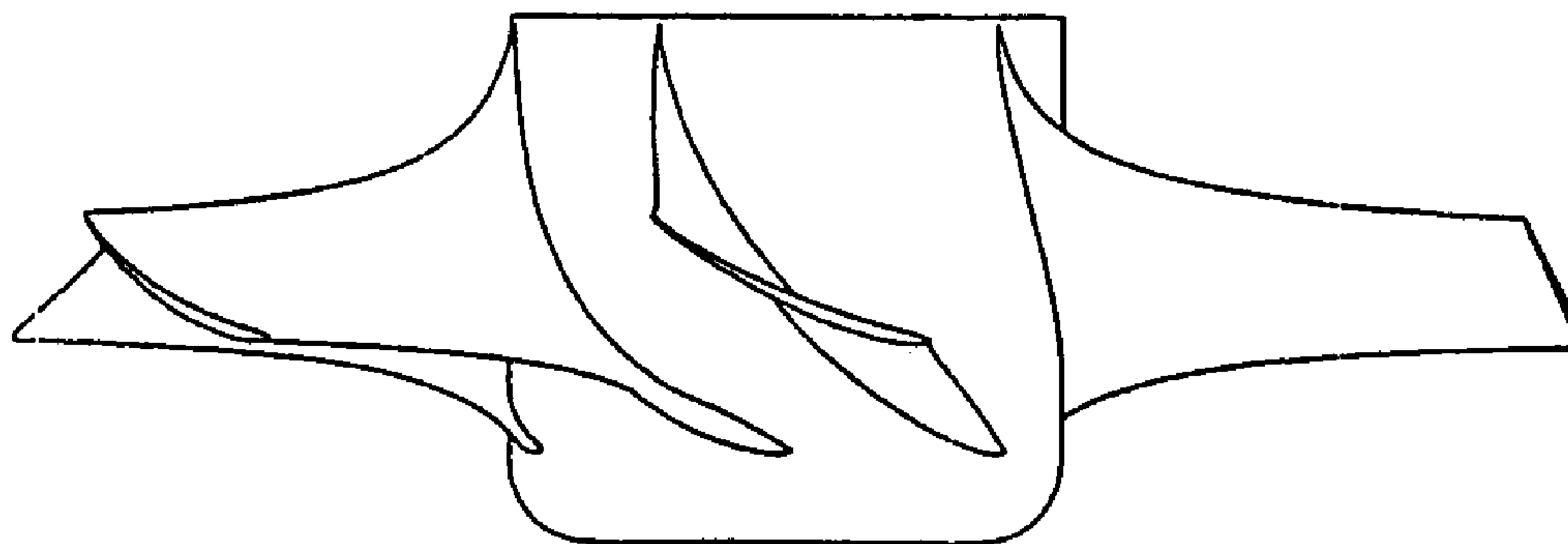

FIG. 15

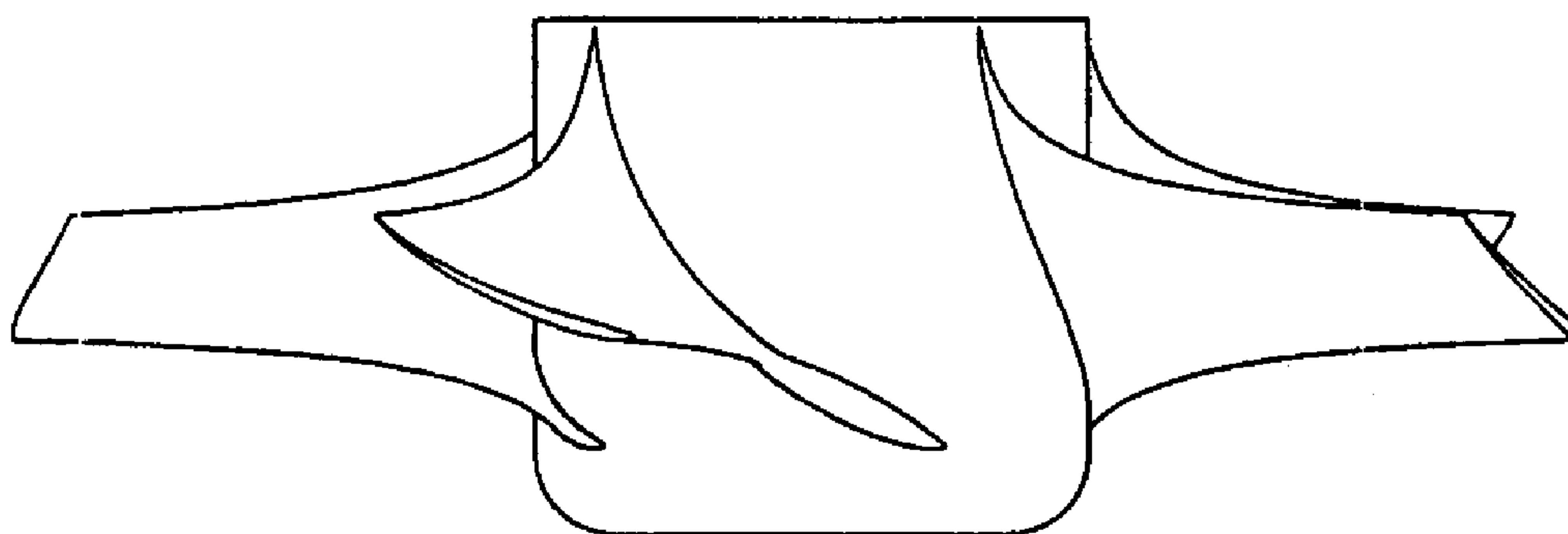

FIG. 16

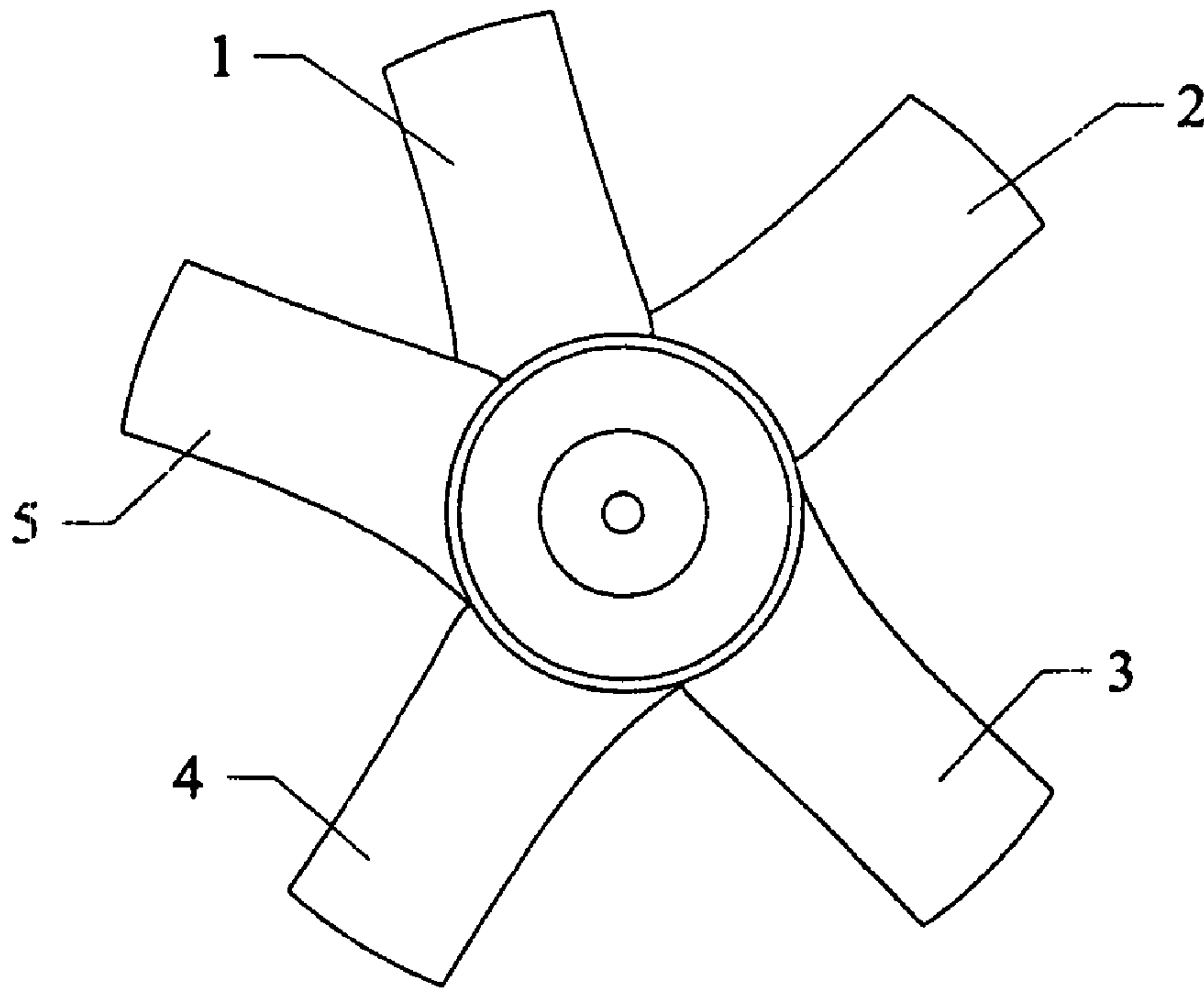

FIG. 17

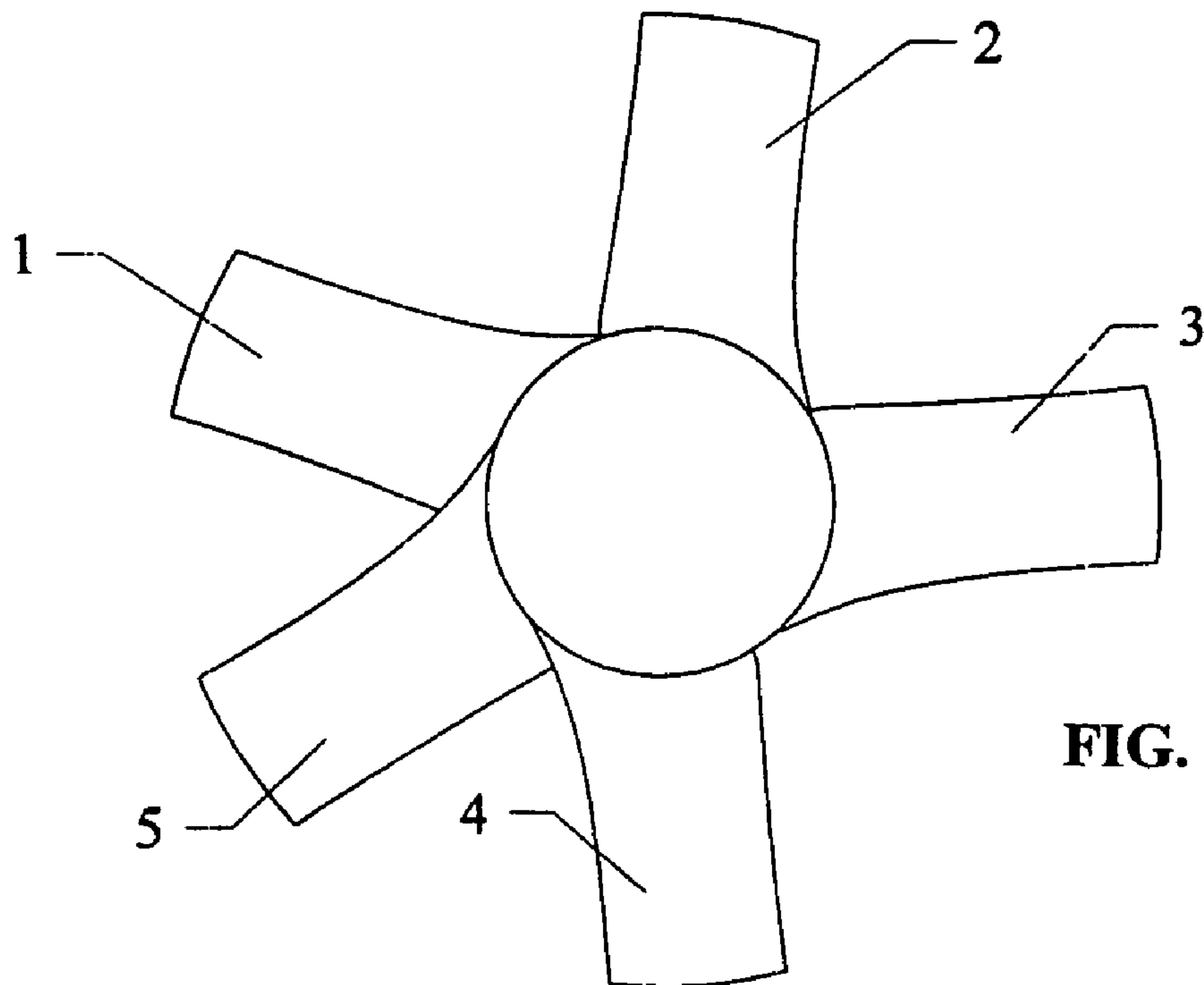

FIG. 18