



US00D555780S

(12) **United States Design Patent**
Wanninger

(10) **Patent No.:** **US D555,780 S**

(45) **Date of Patent:** **** Nov. 20, 2007**

(54) **DRIP PAN**

(76) **Inventor:** **John Wanninger**, 12829 W. Dodge Rd., Ste. 204, Omaha, NE (US) 68154

(**) **Term:** **14 Years**

(21) **Appl. No.:** **29/236,802**

(22) **Filed:** **Jan. 30, 2006**

(51) **LOC (8) Cl.** **23-04**

(52) **U.S. Cl.** **D23/393**

(58) **Field of Classification Search** D23/393,
D23/370, 373, 351, 354, 259, 200; 454/364-368;
220/571; D8/373, 380; D6/512, 513, 566;
184/106; D15/150; D7/402, 359, 601; 62/241,
62/244; 211/41.11; 126/30

See application file for complete search history.

(56) **References Cited**

U.S. PATENT DOCUMENTS

2,524,242	A *	10/1950	Weaver	454/367
3,199,307	A *	8/1965	Willis	62/241
4,054,184	A *	10/1977	Marcinko	184/106
D286,009	S *	10/1986	Nadav	D8/373
D295,313	S *	4/1988	Barnett	D23/373
4,803,816	A *	2/1989	Klober	454/368
D307,623	S *	5/1990	Carbonell	D23/200
D312,038	S *	11/1990	Sachs	D8/373
5,099,873	A *	3/1992	Sanchez	220/571
D336,704	S *	6/1993	Foden	D6/566
D345,890	S *	4/1994	Majors	D7/402
D363,944	S *	11/1995	McCarter	D15/150
D383,355	S *	9/1997	Uter	D7/359

5,791,156	A *	8/1998	Strautman et al.	62/244
5,979,673	A *	11/1999	Dooley	211/41.11
D468,163	S *	1/2003	Blake et al.	D7/601
D483,224	S *	12/2003	Clark	D7/402
D518,669	S *	4/2006	Rafoth et al.	D6/513
2003/0200961	A1 *	10/2003	Tiernan	126/30

* cited by examiner

Primary Examiner—Ian Simmons

Assistant Examiner—David G. Muller

(74) *Attorney, Agent, or Firm*—Harness, Dickey & Pierce, P.L.C.

(57) **CLAIM**

The ornamental design for a drip pan, as shown and described.

DESCRIPTION

FIG. 1 is a left front perspective view of a drip pan showing my new design;

FIG. 2 is a front elevation view thereof;

FIG. 3 is a side elevation view, showing extended portions of the drip pan along the length of the pan, shown broken on each end to show indeterminate length. The opposite side of that shown is a mirror image thereof;

FIG. 4 is a top view thereof;

FIG. 5 is a side elevation view of a drip pan of FIG. 1; and,

FIG. 6 is a front elevation view thereof.

The dashed lines represent environmental elements only and form no part of the claimed design.

1 Claim, 2 Drawing Sheets

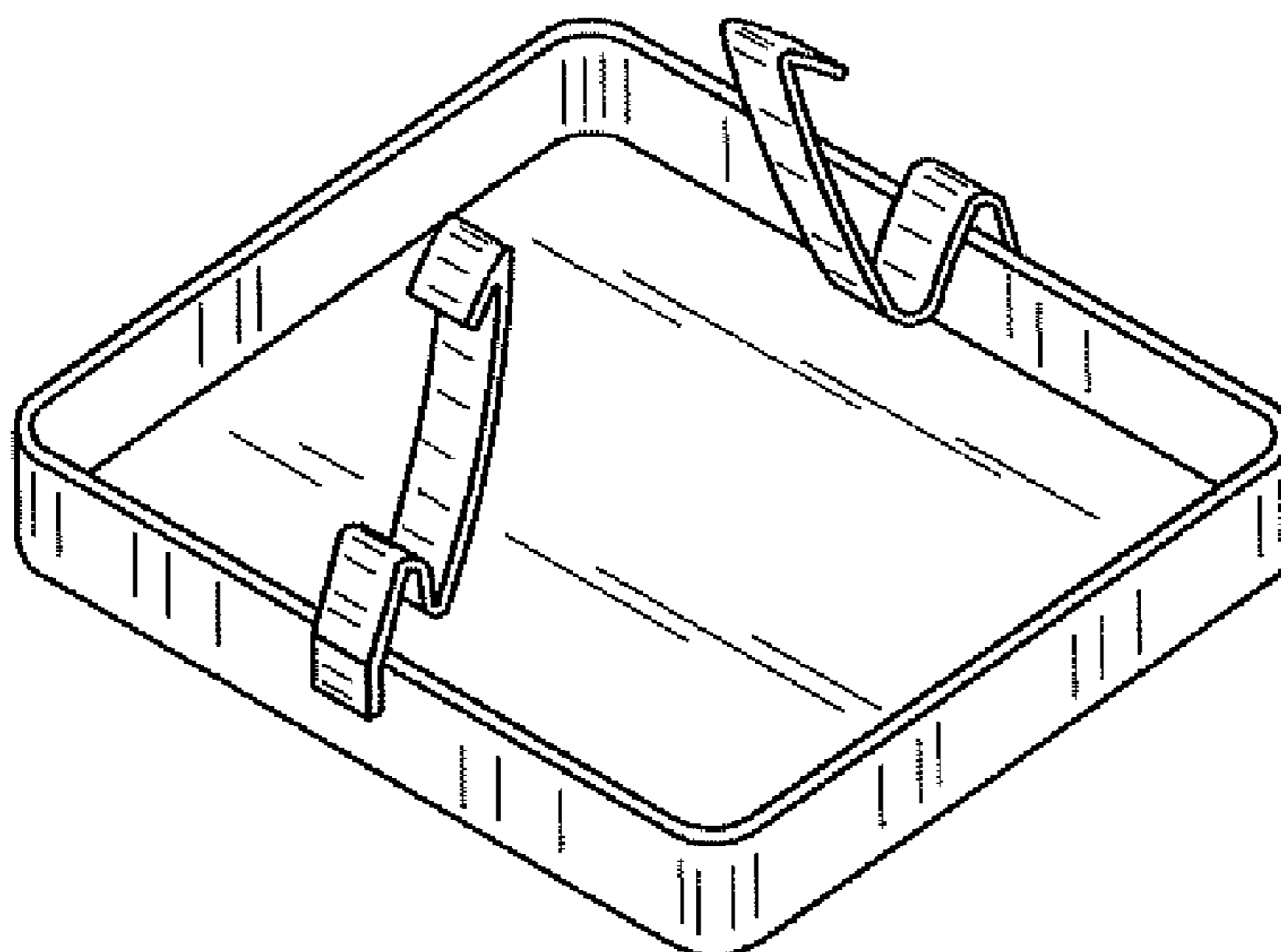

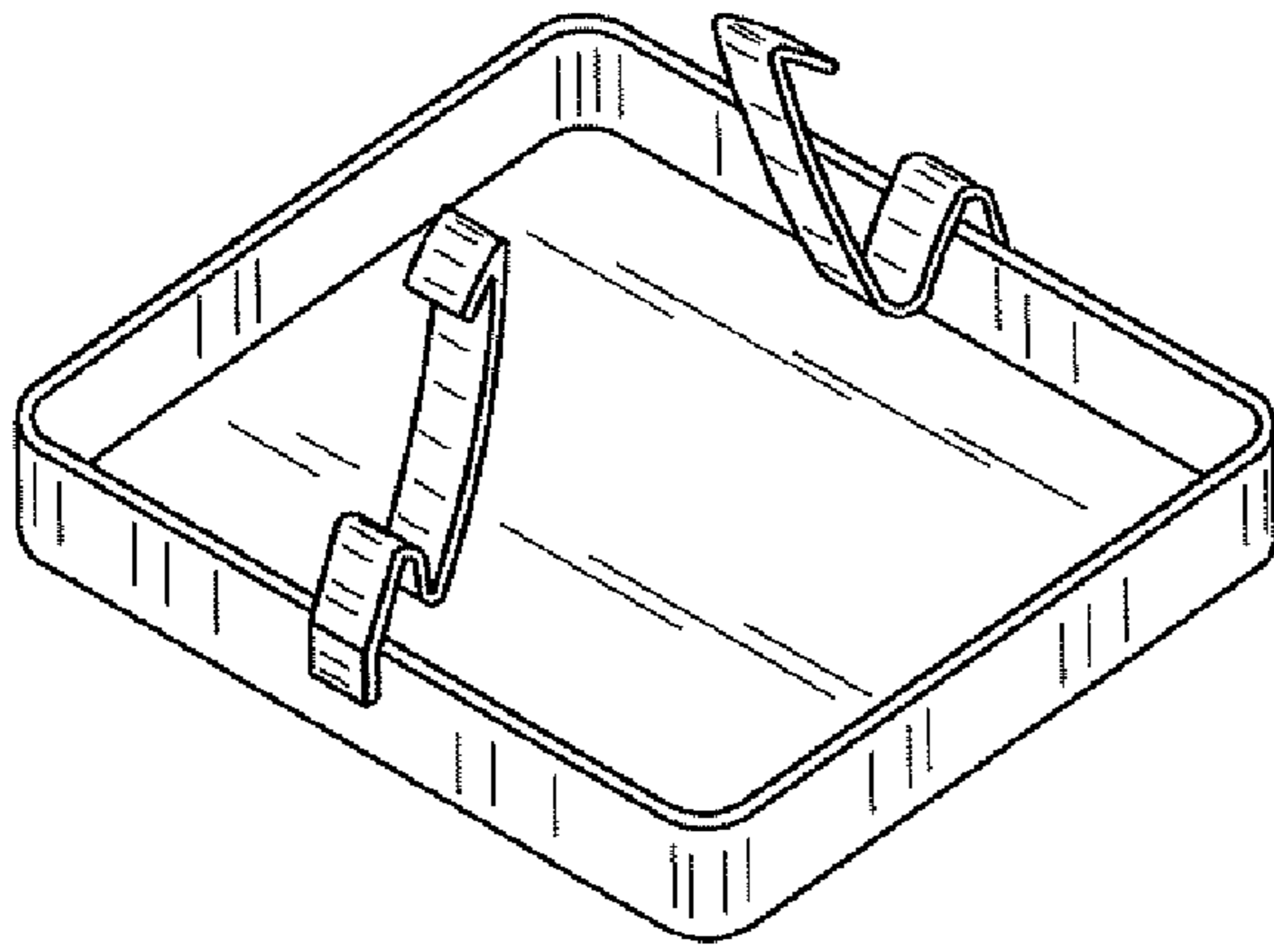

FIG. 1

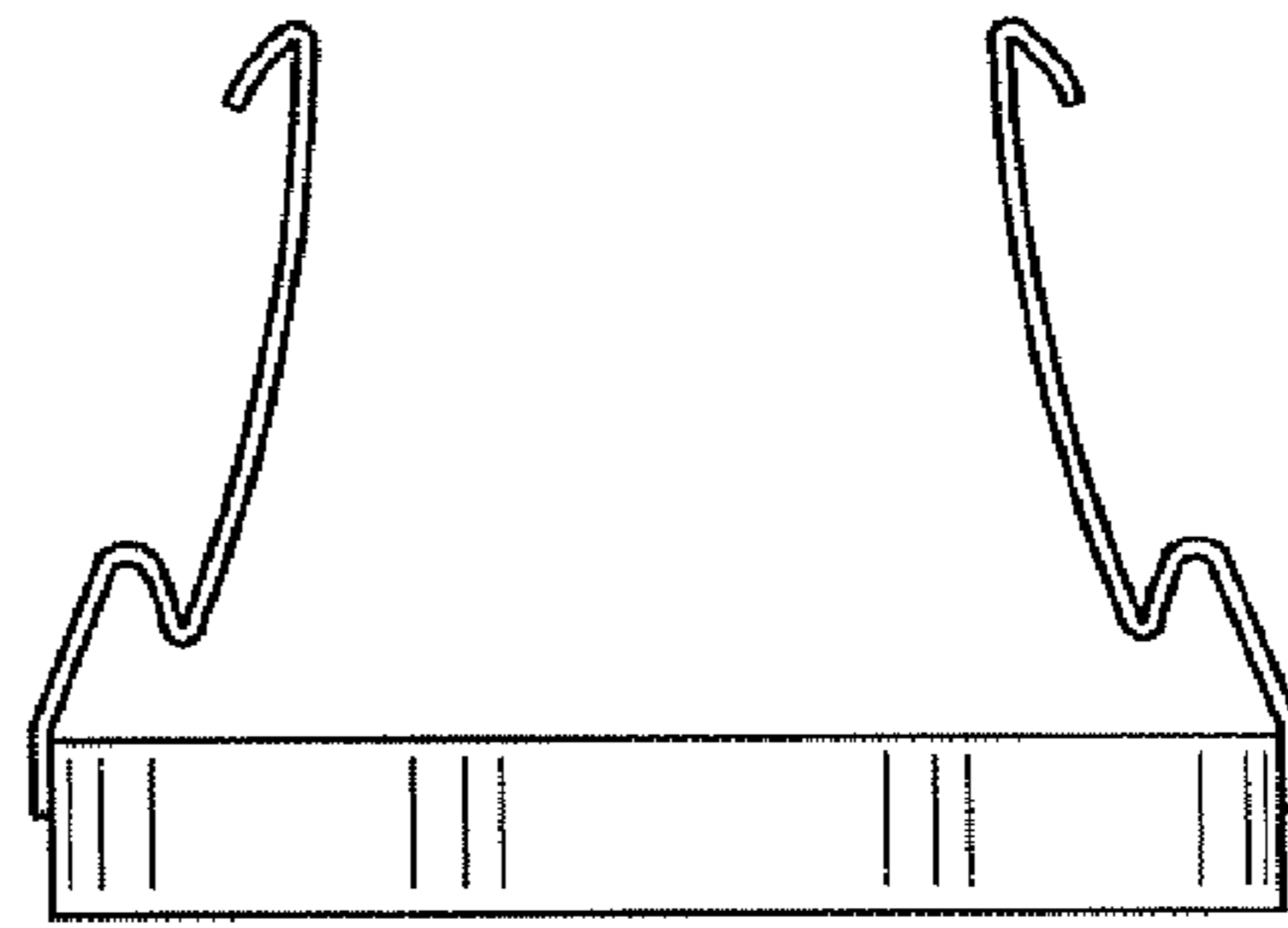

FIG. 2

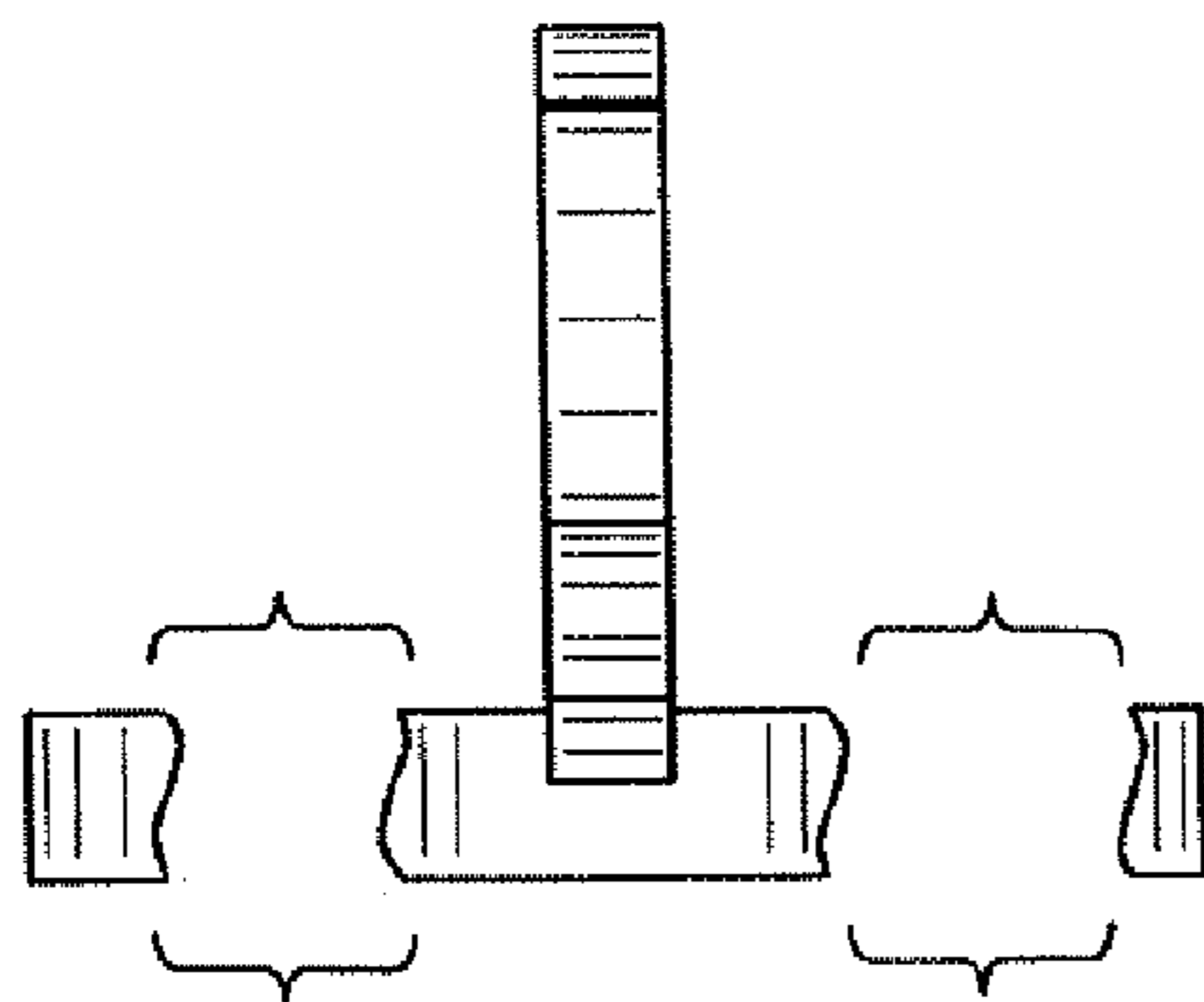

FIG. 3

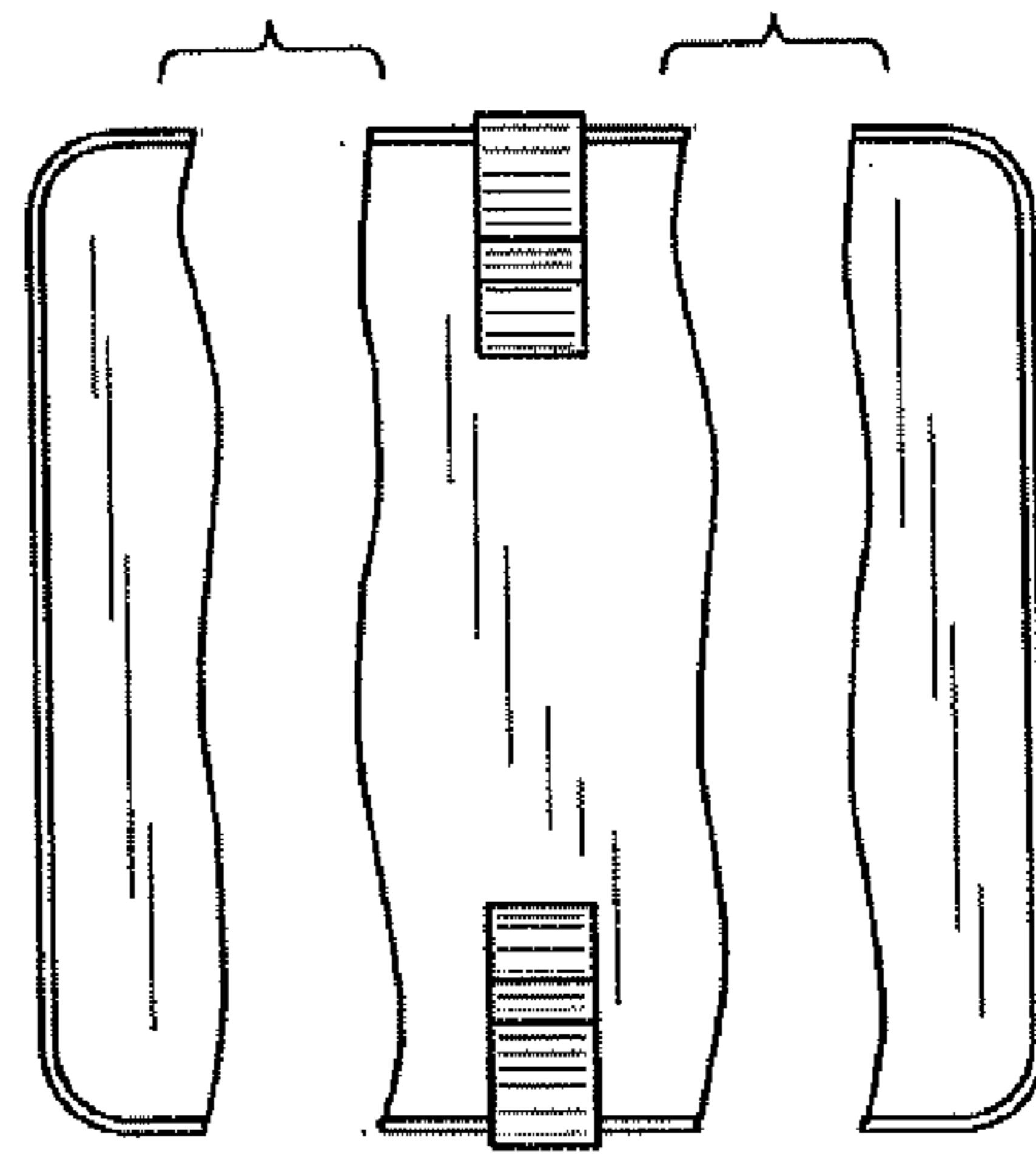

FIG. 4

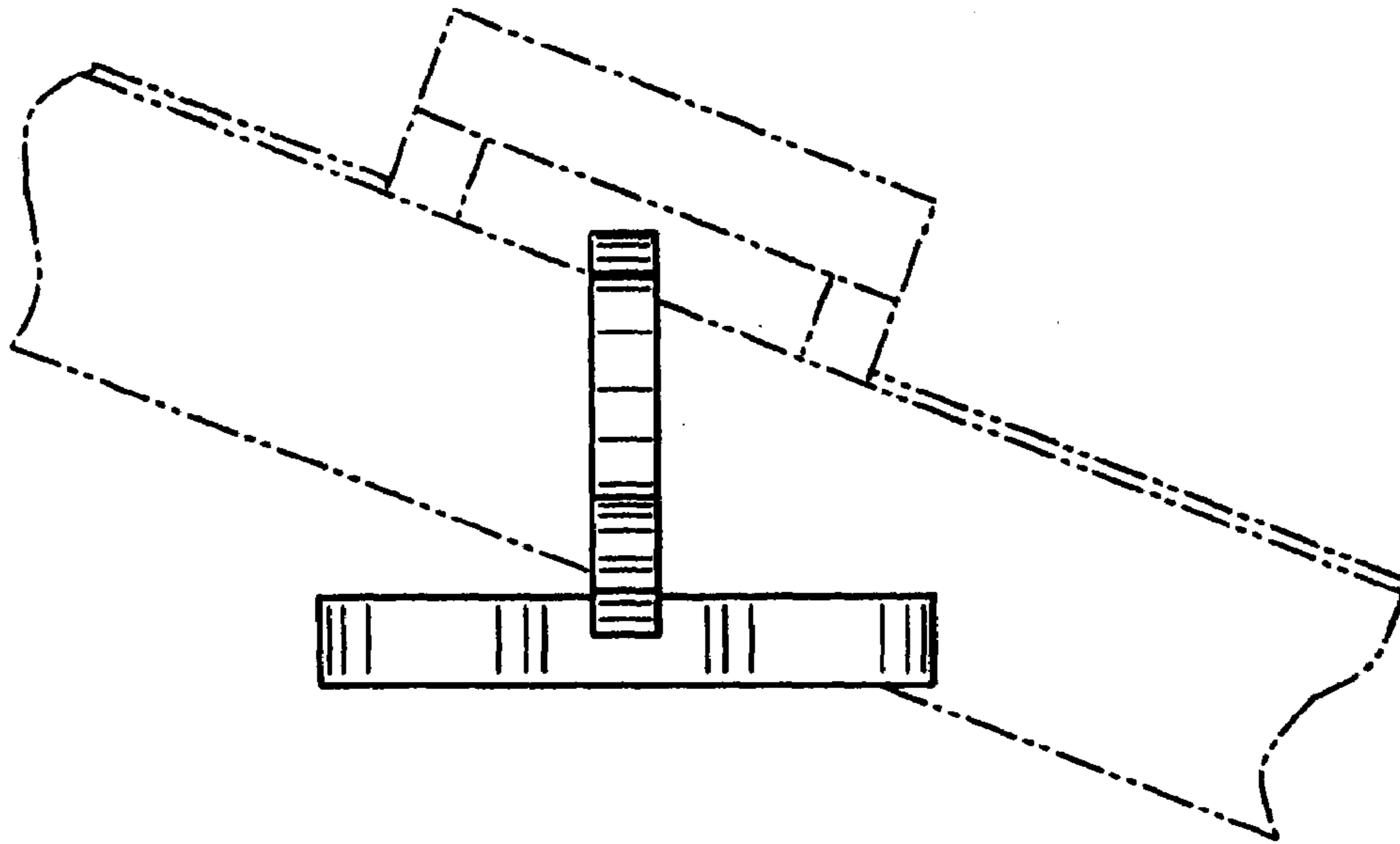

FIG. 5

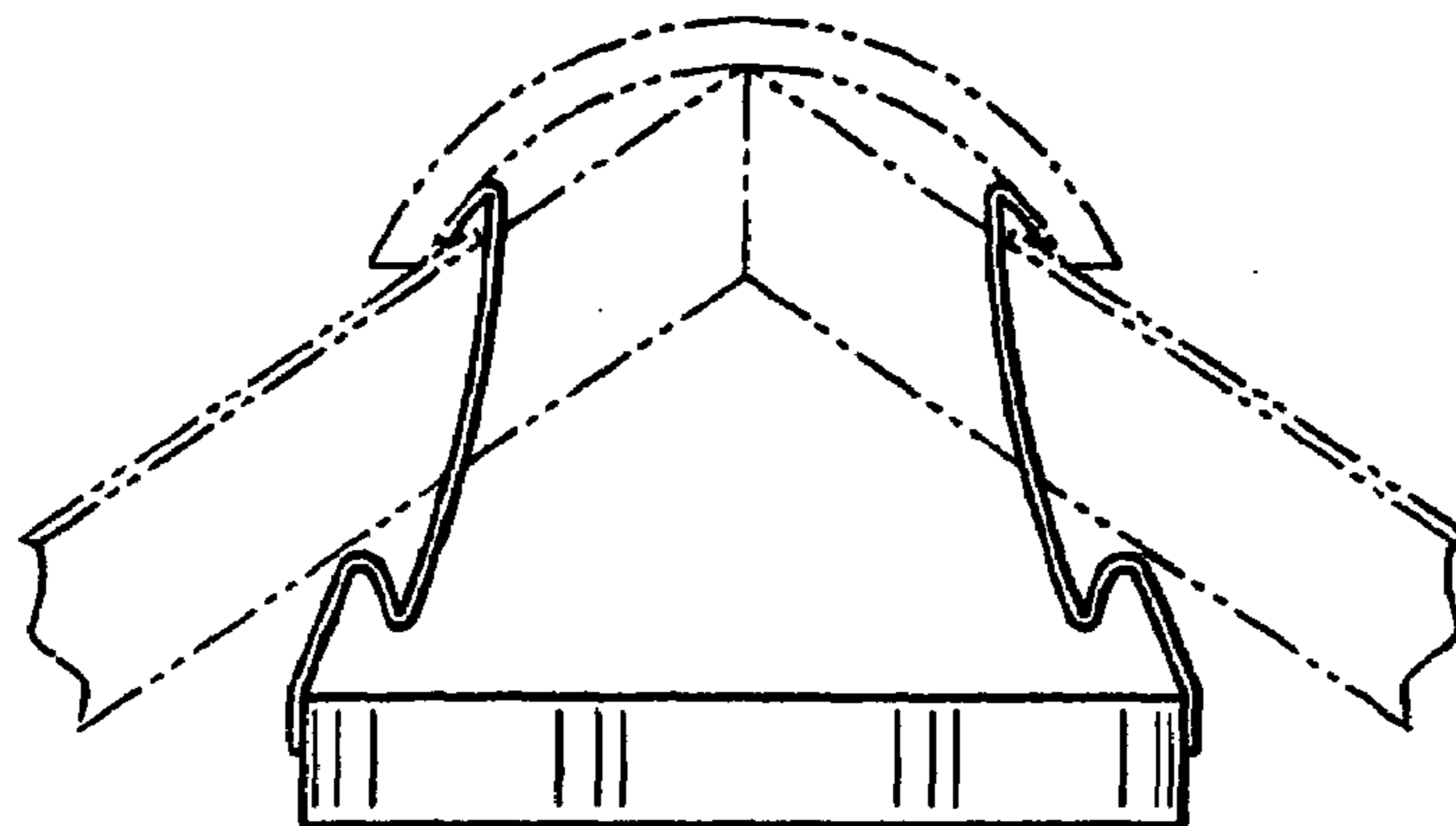

FIG. 6