



US00D555380S

(12) **United States Design Patent** (10) **Patent No.:** **US D555,380 S**  
**Farber** (45) **Date of Patent:** **\*\* \*Nov. 20, 2007**

- (54) **STACKING CHAIR**
- (75) Inventor: **Robert Farber**, Montreal (CA)
- (73) Assignee: **GSC Technologies Corporation**, St. Jean (CA)
- (\*) Notice: This patent is subject to a terminal disclaimer.
- (\*\*) Term: **14 Years**
- (21) Appl. No.: **29/276,188**
- (22) Filed: **Jan. 18, 2007**
- (51) **LOC (8) Cl.** ..... **06-01**
- (52) **U.S. Cl.** ..... **D6/375; D6/380**
- (58) **Field of Classification Search** ..... D6/334, D6/335, 336, 360, 374, 375, 376, 379, 380, D6/500-502; 297/239, 411.4, 411.41, 445.1  
See application file for complete search history.

- D334,671 S 4/1993 Mayer
- D335,042 S 4/1993 Gibbs
- D336,385 S 6/1993 Gibbs
- D339,006 S 9/1993 Schneider
- D339,245 S 9/1993 Grosfillex
- D341,038 S 11/1993 Danko
- D343,964 S 2/1994 Gibbs
- D358,514 S 5/1995 Lovegrove
- D361,908 S 9/1995 Sauvage
- D364,973 S 12/1995 de Reuver
- D365,454 S 12/1995 Thomson

(Continued)

**OTHER PUBLICATIONS**

Phil Patton, "Craft: From Eureka to Your House", New York Times Magazine, Dec. 13, 1998, pp. 97-100, USA.  
Umbra 1999 Supplemental Catalog, image of chair designed by Karim Rashid, p. 30, USA.

(Continued)

*Primary Examiner*—Mimosa De  
(74) *Attorney, Agent, or Firm*—Cook, Alex, McFarron, Manzo, Cummings & Mehler, Ltd.

(56) **References Cited**

**U.S. PATENT DOCUMENTS**

- D181,945 S 1/1958 Saarinen
- D183,416 S 8/1958 Bellmann
- D193,847 S 10/1962 Mason
- D205,939 S 10/1966 Laverne et al.
- D207,955 S \* 6/1967 Rodrigo ..... D6/375
- D209,282 S 11/1967 Boyd et al.
- D226,648 S 4/1973 Sebel et al.
- D230,670 S 3/1974 Begge
- D237,023 S \* 10/1975 Rossi ..... D6/360
- D238,837 S 2/1976 Mulhauser
- D239,234 S 3/1976 Gamble
- D255,184 S 6/1980 Locher
- D259,688 S 6/1981 Ambasz
- D265,961 S 8/1982 Snodgrass
- D274,771 S 7/1984 Ambasz et al.
- D282,224 S 1/1986 Huldt
- D288,506 S 3/1987 Ochsner
- D299,191 S 1/1989 Frinier

(57) **CLAIM**

The ornamental design for the stacking chair, as shown and described.

**DESCRIPTION**

FIG. 1 is front perspective view of the design of the present invention.  
FIG. 2 is a rear view of the design shown in FIG. 1.  
FIG. 3 is a front view of the design shown in FIG. 1.  
FIG. 4 is a right side view of the design shown in FIG. 1, with left side being a mirror image thereof.  
FIG. 5 is a bottom view of the design shown in FIG. 1; and, FIG. 6 is a top view of the design shown in FIG. 1.

**1 Claim, 4 Drawing Sheets**

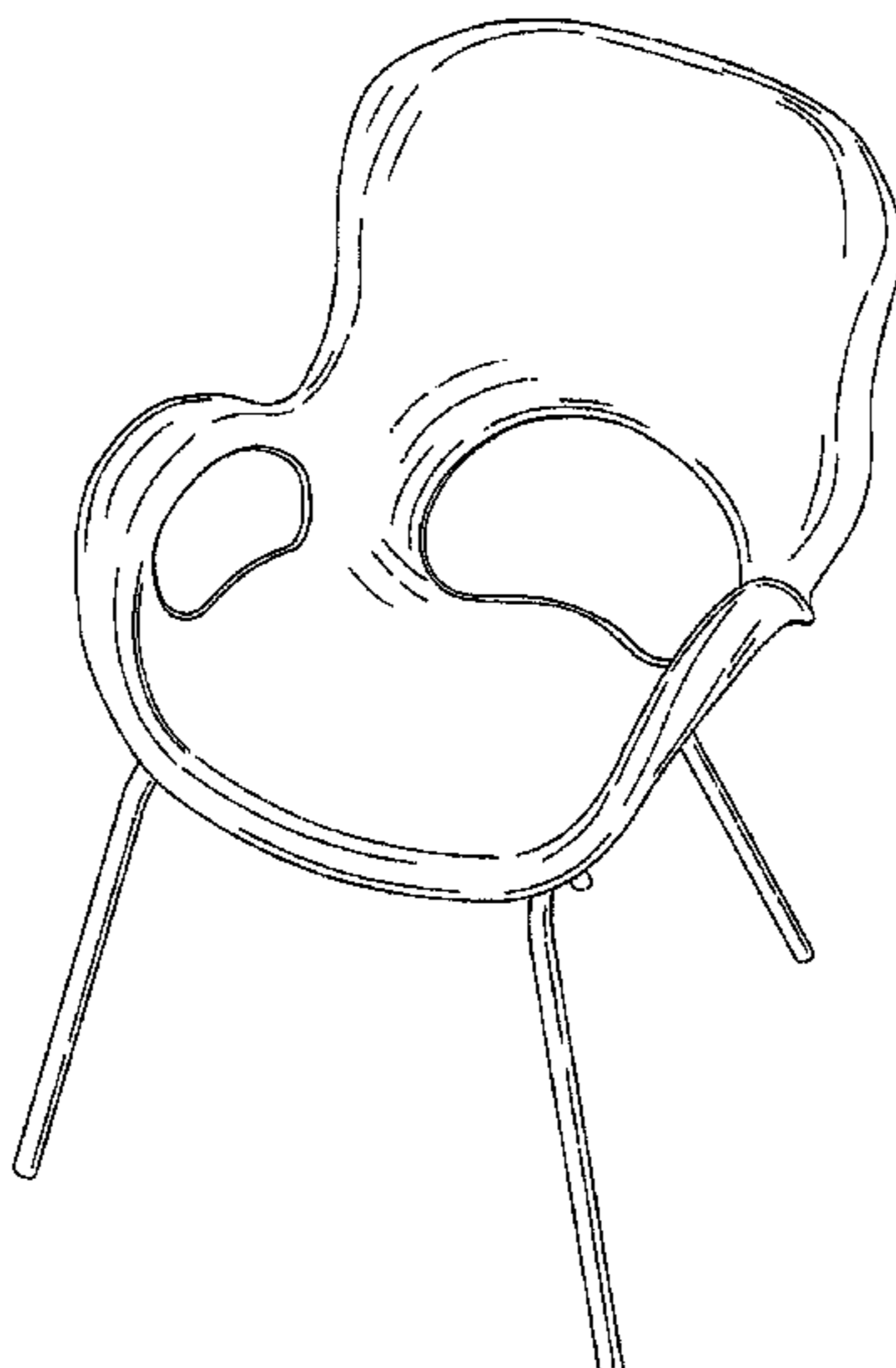

U.S. PATENT DOCUMENTS

D367,182 S	2/1996	Bonaddio et al.	
D373,273 S	9/1996	Zapf	
D393,158 S	4/1998	Smith	
D406,196 S	3/1999	Lyons	
D417,795 S	12/1999	Rashid	
D417,968 S	12/1999	Van Rhiemen	
D422,805 S	4/2000	Smith	
D440,064 S	4/2001	Deacon	
D465,100 S	11/2002	Savini	
D470,320 S	* 2/2003	Schloss .....	D6/375
D471,729 S	3/2003	Glass et al.	
D488,631 S	4/2004	Newhouse	
D503,560 S	4/2005	Rowland et al.	
D525,445 S	* 7/2006	Liu et al. ....	D6/375
D525,446 S	7/2006	Farber	

OTHER PUBLICATIONS

Mark Borden, "Umbral: When Only the Hippest Trash Can Will Do", *Fortune*, Mar. 6, 2000, p. 82, USA.  
 "Do The Math", Umbral mailing to customers, May 17, 2000, images of chair by Karim Rashid, no page numbers, USA.  
 "coolroom", *COSMO girl!*, Jun./Jul. 2001, image of chair, p. 122, USA.  
 "wise buys", *InStyle*, Jul. 2001, vol. 8, No. 8, image of chair by Karim Rashid, page number not available, USA.

Natalie Warady, "The Best Seats in the House . . . don't cost a fortune, even if you buy six", *Budget Living*, Oct./Nov. 2002, p. 36, USA.  
 Hilary Irlam-Kelley, "oh, my!", *flare&co.*, Apr. 2003, p. 205, vol. 25, Issue 4, image of chair by Karim Rashid for Umbral.  
 "Perfekte Popgrotte S. 30", *H.O.M.E.* (Germany), Jul./Aug. 2003, no page number, Germany.  
 Davida J. Sidrane, "homefinds—Brighten up for summer", *Woman's Day*, Aug. 5, 2003, *Shopper's Guide* section-page number not legible, USA.  
 "As Seen on TV", *House and Garden*, Sep. 2003, p. 46, image of chair, USA.  
 "finishing touches", *Parents*, Oct. 2003, p. 232, image of a chair, USA.  
 Simon Yates, "An Encyclopedia of Chairs", 1988, pp. 58-59, 109, 111,119, *Wellfleet Press*, USA.  
 Clement Meadmore, "The Modern Chair: Classic Designs by Thonet, Breuer, Le Corbusier, Eames and Others", 1997, pp. 96-99, 110-113, 130-133, *Dover Publications, Inc.*, USA.  
 Charlotte and Peter Fiell, "Modern Furniture Classics: Postwar to post-modernism", 2001, pp. 13, 37, 62-63, 65, 148, *Thames & Hudson Inc.*, UK.  
 Patricia Bueno, "Just Chairs: Over 600 Designs from Around the World", 2003, pp. 67, 137, 161, 202, 224, 254, 262, *Harper Design International*, USA.

\* cited by examiner

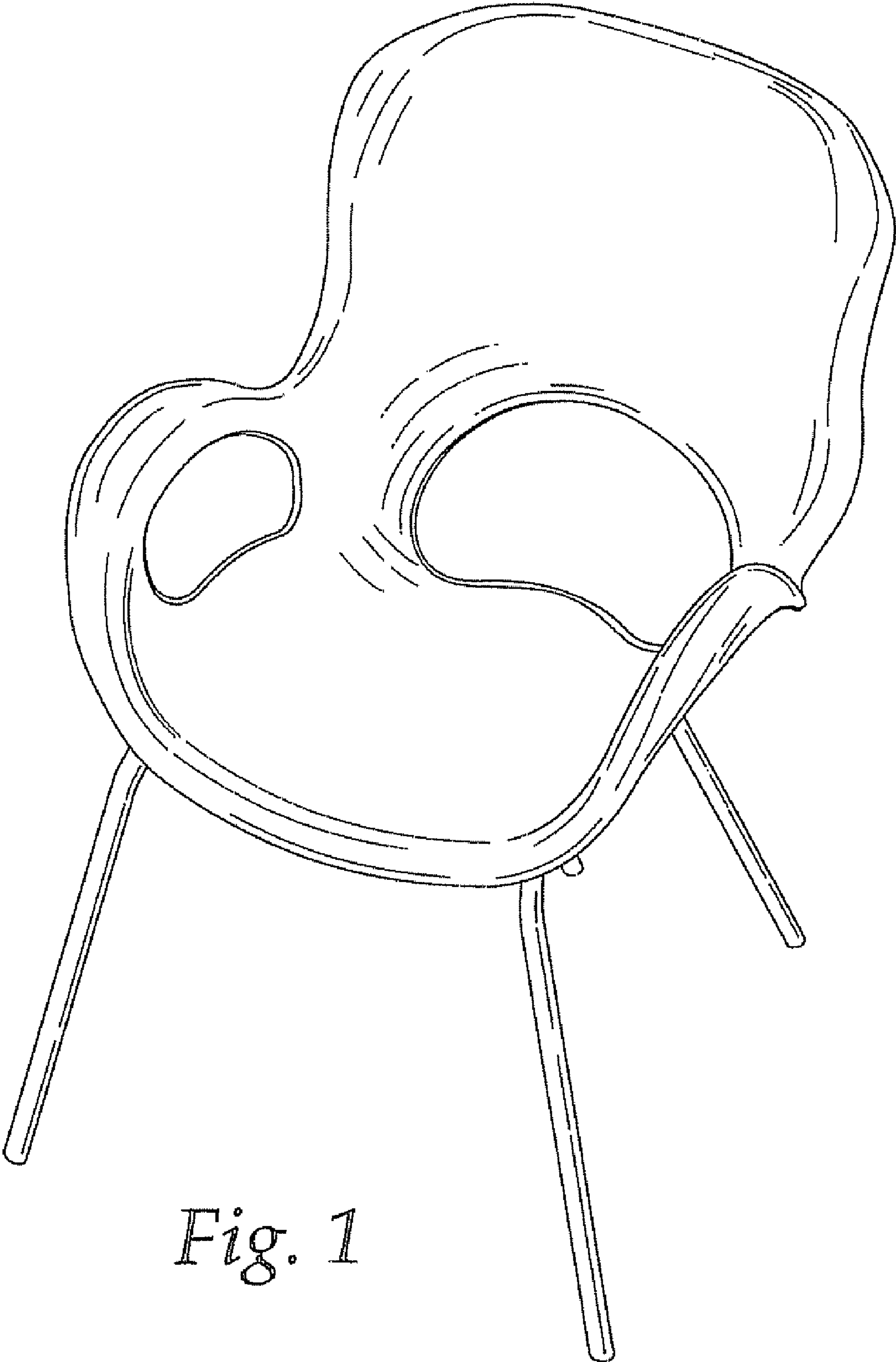

*Fig. 1*

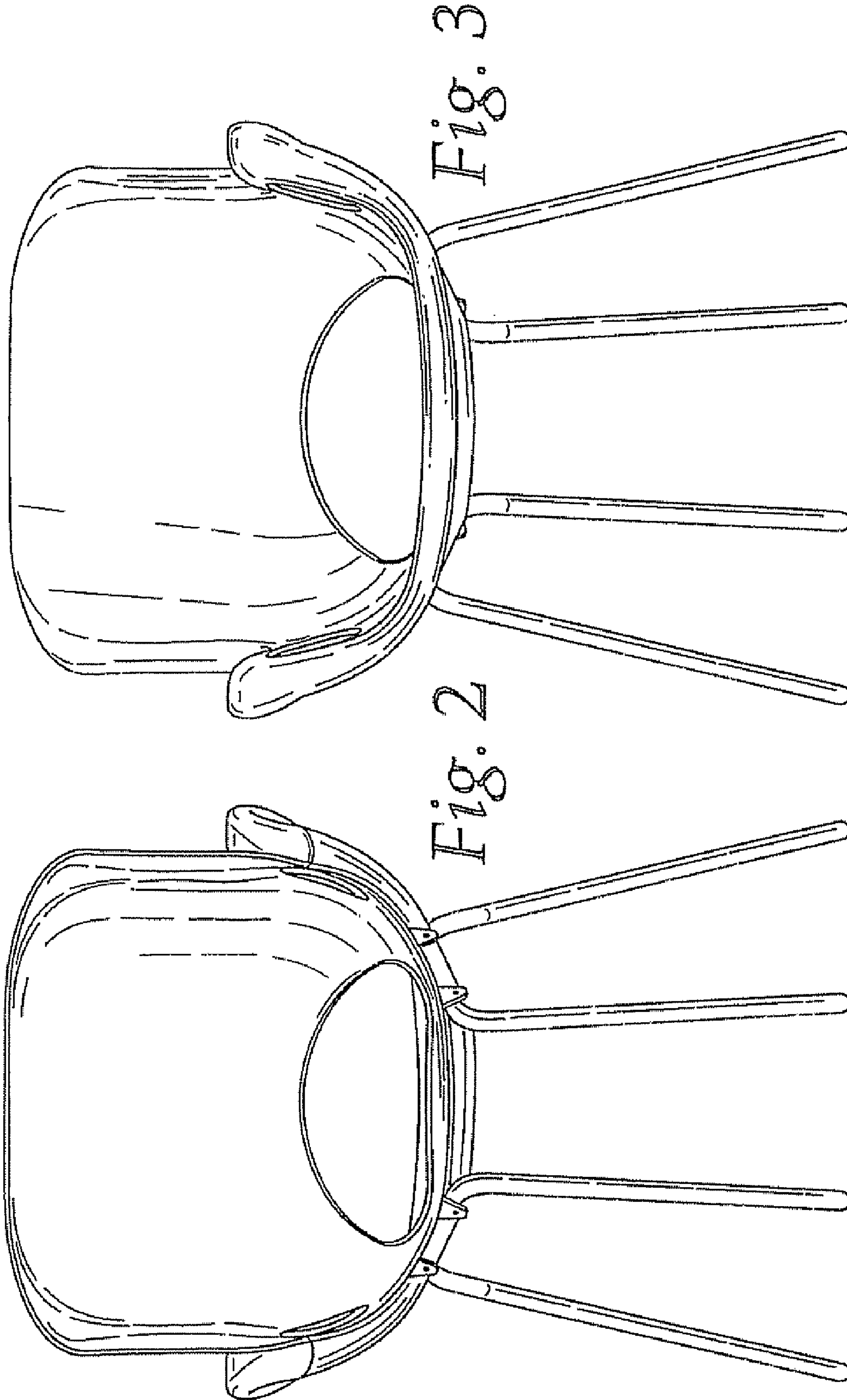



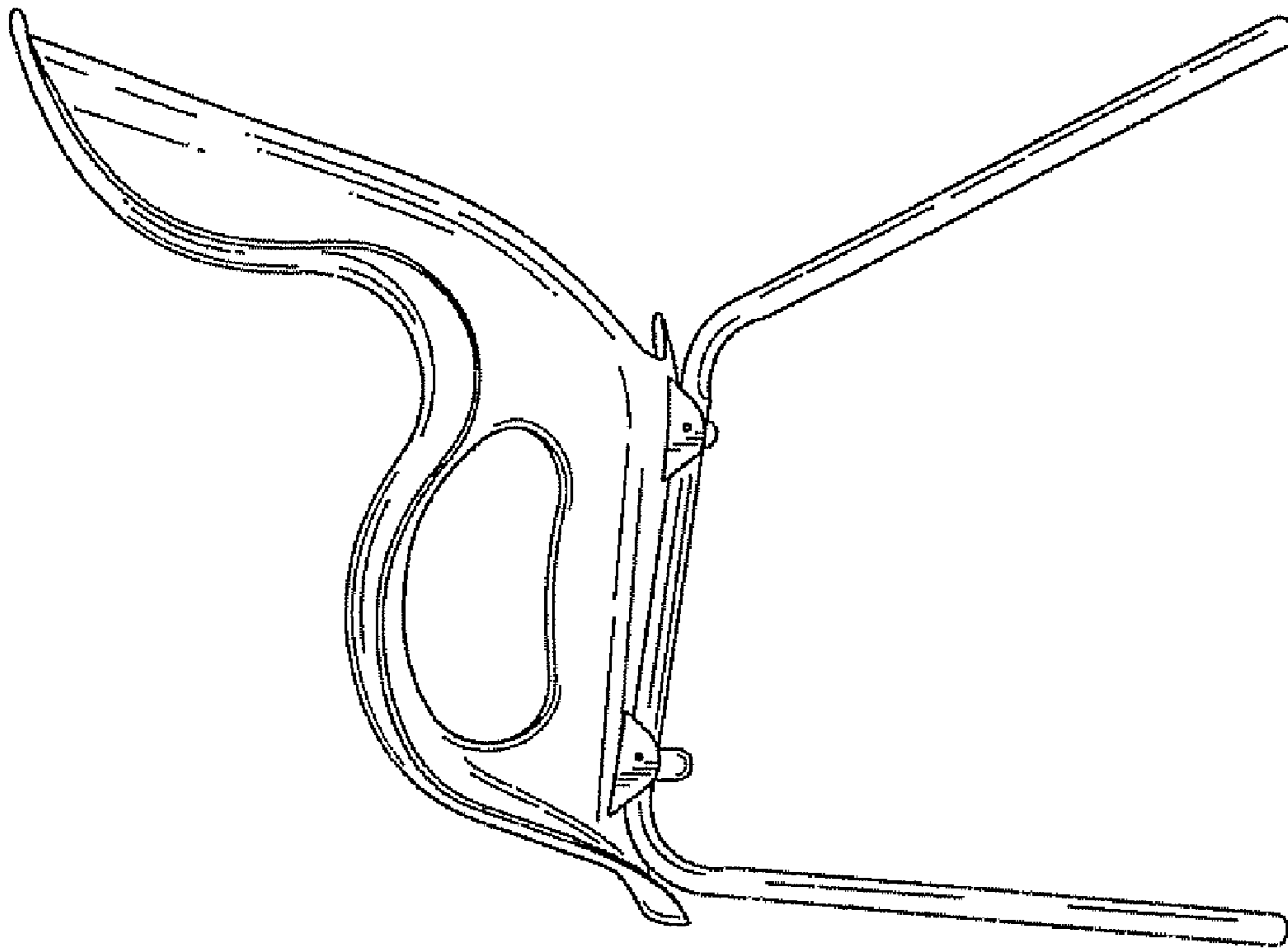

Fig. 4

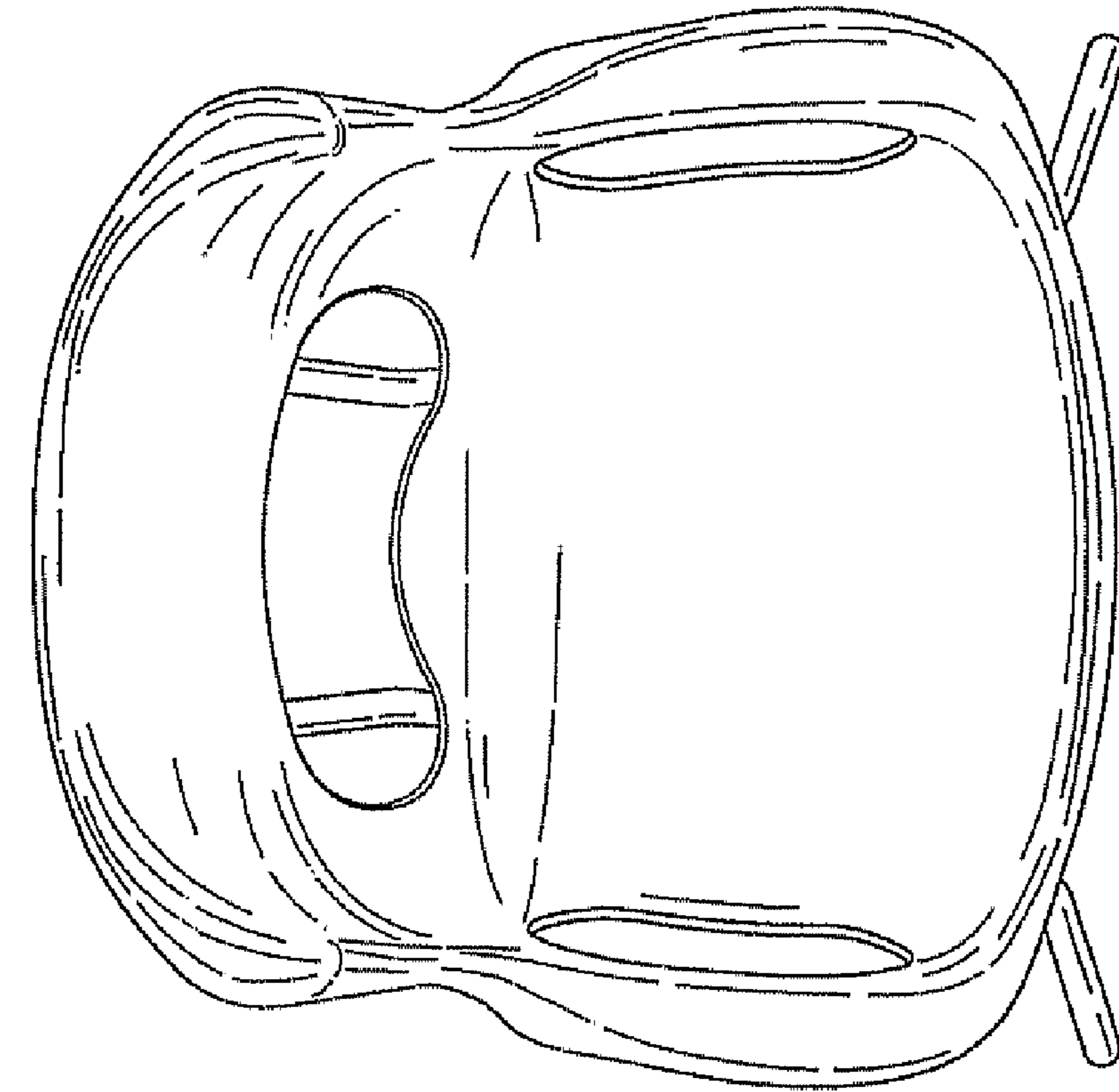

Fig. 6

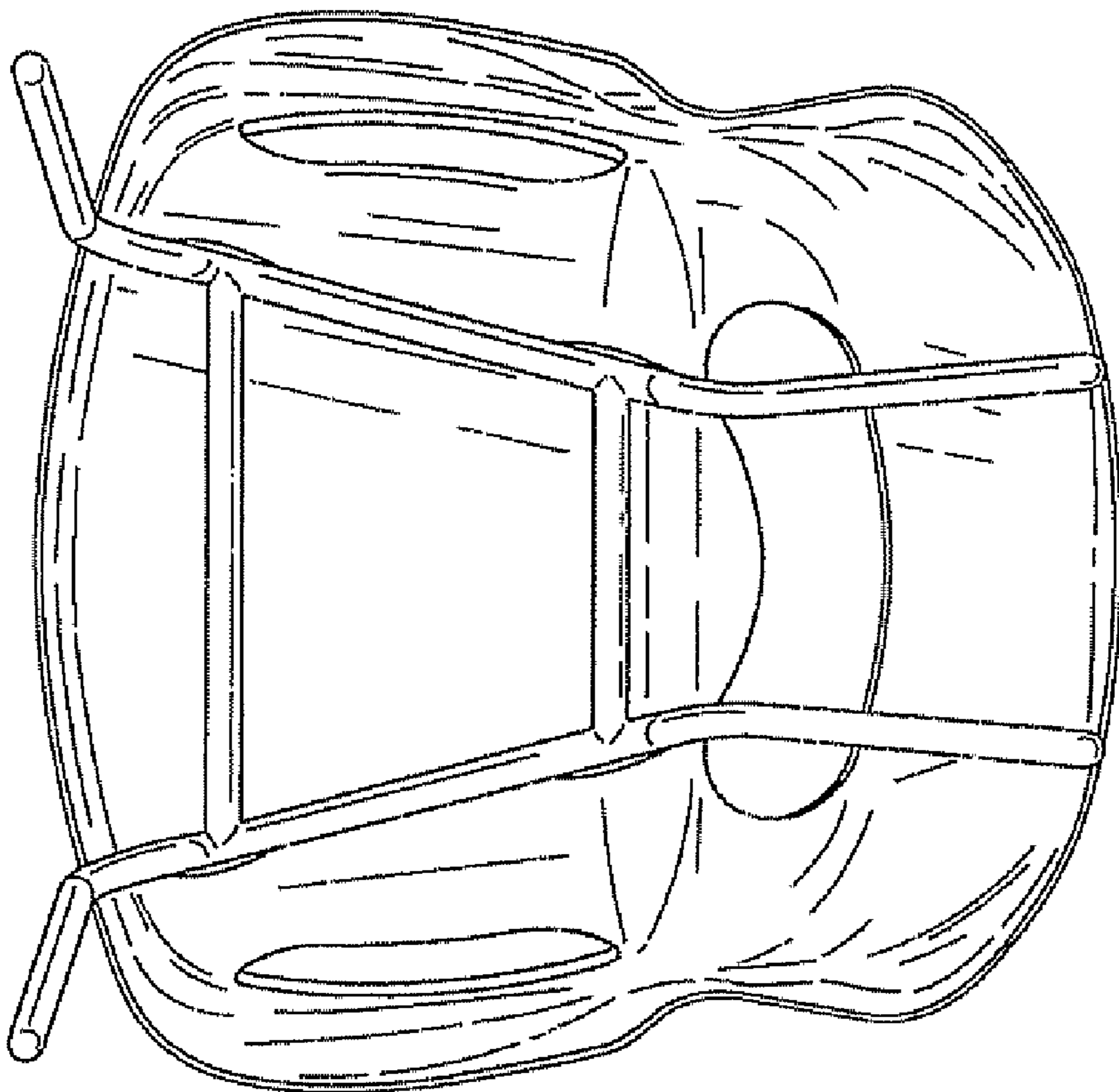

Fig. 5