



US00D555194S

(12) **United States Design Patent**  
**Smith et al.**

(10) **Patent No.:** **US D555,194 S**

(45) **Date of Patent:** **\*\* Nov. 13, 2007**

(54) **PRINTER HOUSING**

(75) Inventors: **Michael Smith**, Austin, TX (US); **Gadi Amit**, Belmont, CA (US); **Kuoyong Huang**, Cedar Park, TX (US); **Michael Massuco**, Oakland, CA (US)

(73) Assignee: **Dell Products L.P.**, Round Rock, TX (US)

(\*\*) Term: **14 Years**

(21) Appl. No.: **29/248,834**

(22) Filed: **Sep. 7, 2006**  
(Under 37 CFR 1.47)

(51) **LOC (8) Cl.** ..... **14-02**

(52) **U.S. Cl.** ..... **D18/55**

(58) **Field of Classification Search** ..... D18/50,  
D18/54, 54.1, 55; D14/420-425, 462-470;  
400/613, 613.1-613.4, 691-694, 690.1-690.4  
See application file for complete search history.

(56) **References Cited**

**U.S. PATENT DOCUMENTS**

D436,369 S *	1/2001	Sasaki et al.	.....	D18/39
D494,211 S *	8/2004	Yoshida et al.	.....	D18/39
D501,667 S *	2/2005	Ishigami et al.	.....	D18/50
D501,874 S	2/2005	Ishigami	.....	D18/50
D502,500 S *	3/2005	Hoshiya et al.	.....	D18/50
D502,732 S	3/2005	Ishigami	.....	D18/50
D505,154 S	5/2005	Wong et al.	.....	D18/50
D518,515 S *	4/2006	Miyauchi et al.	.....	D18/55

7,062,197 B2 *	6/2006	Kunugi	.....	399/107
D528,155 S *	9/2006	Katayama	.....	D18/55
D532,449 S *	11/2006	Tjin Wong Joe et al.	....	D18/55
D532,450 S *	11/2006	Smith et al.	.....	D18/55
D533,218 S *	12/2006	Gant et al.	.....	D18/55
D534,578 S *	1/2007	Katayama et al.	.....	D18/55
D536,372 S *	2/2007	Lim et al.	.....	D18/53
D545,357 S *	6/2007	Hattori et al.	.....	D18/55

\* cited by examiner

*Primary Examiner*—Cathy Anne MacCormac

(74) *Attorney, Agent, or Firm*—Hamilton & Terrile, LLP;  
Robert W. Holland

(57) **CLAIM**

The ornamental design for a printer housing, as shown and described.

**DESCRIPTION**

FIG. 1 is an enlarged right front perspective view of a printer housing comprising the present invention;

FIG. 2 is a front elevation view thereof;

FIG. 3 is a right side elevation view thereof;

FIG. 4 is a left side elevation view thereof;

FIG. 5 is a rear elevation view thereof; and,

FIG. 6 is a top plan view thereof.

The broken lines are for illustrative purposes only and form no part of the claimed design.

**1 Claim, 4 Drawing Sheets**

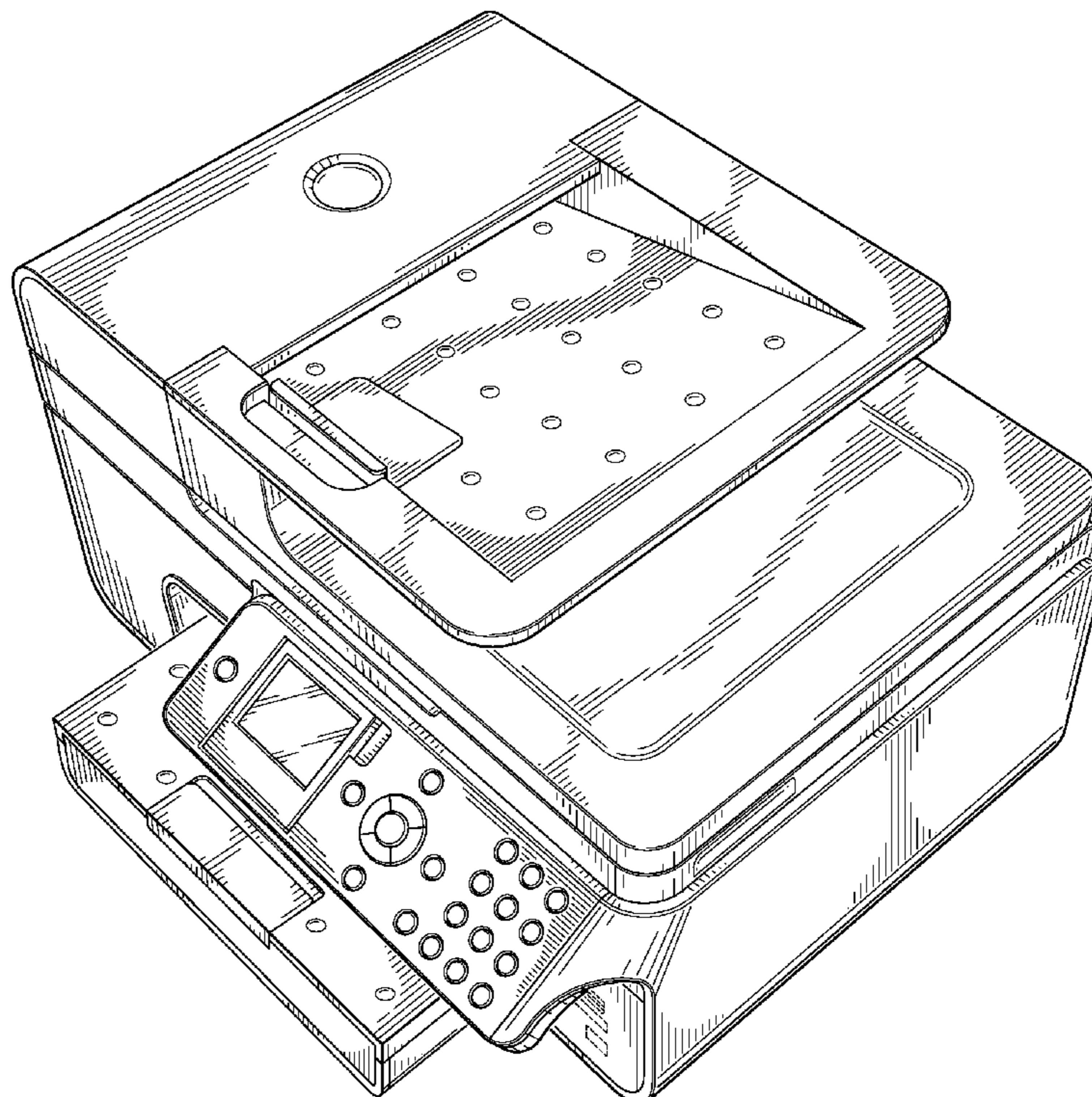

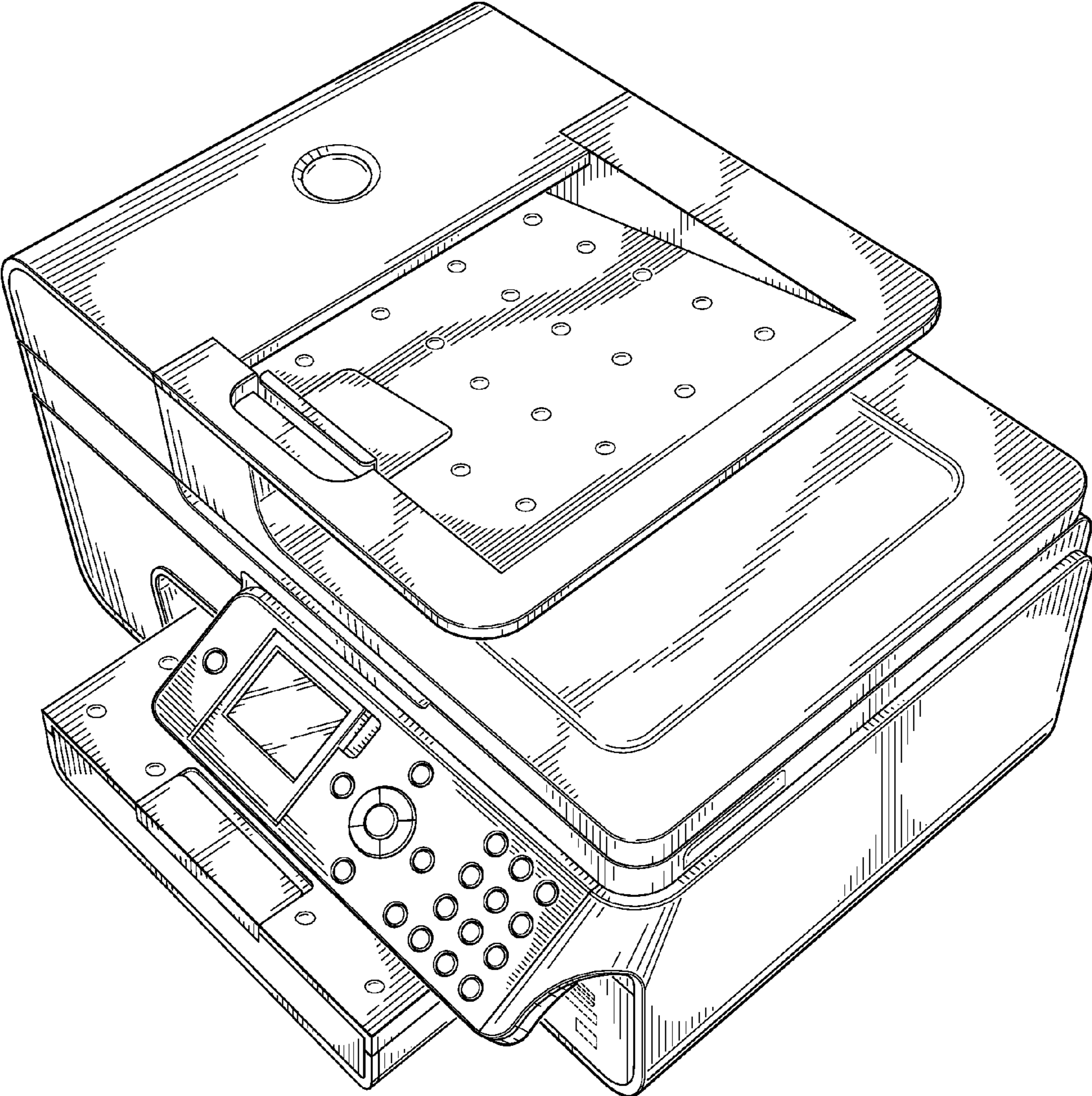

FIG. 1

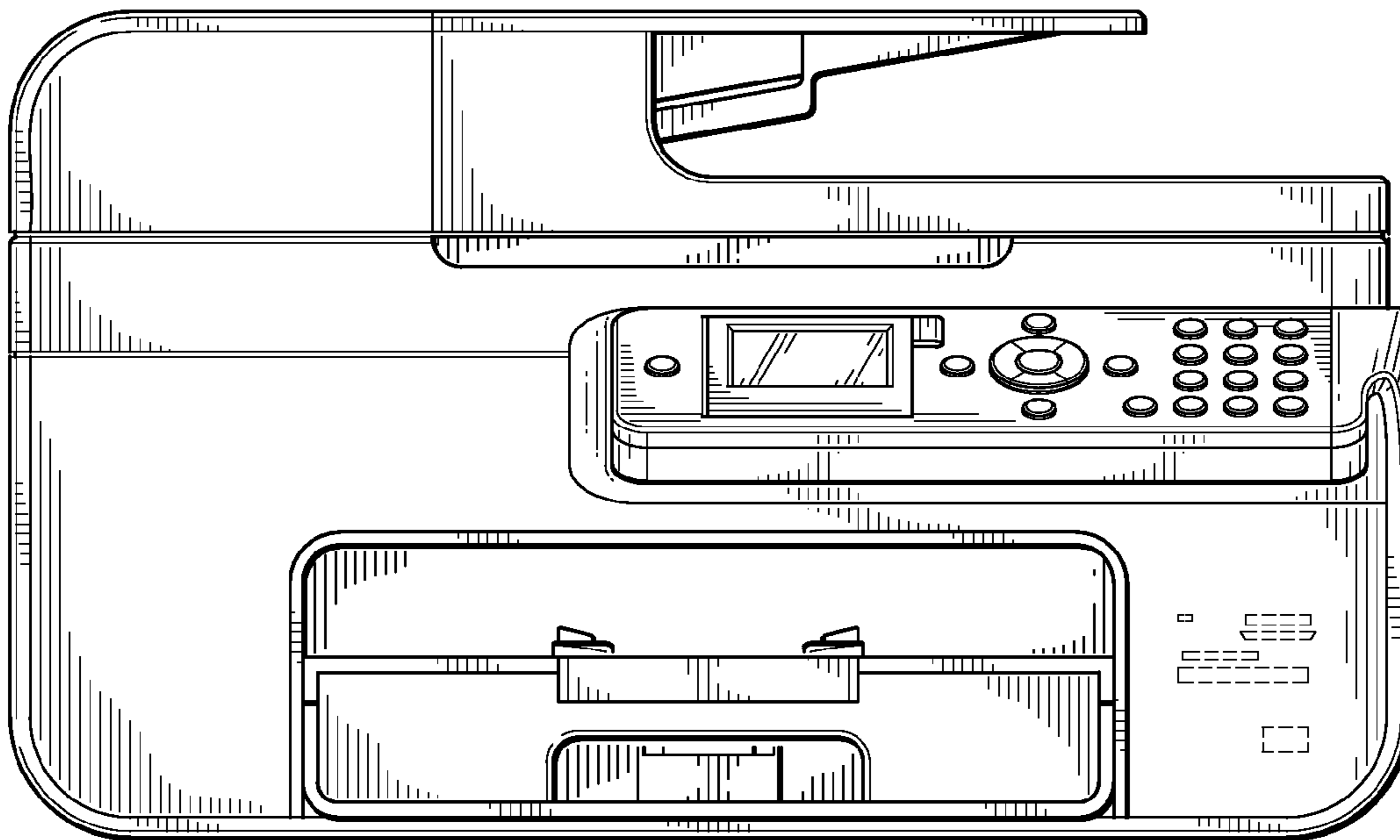

FIG. 2

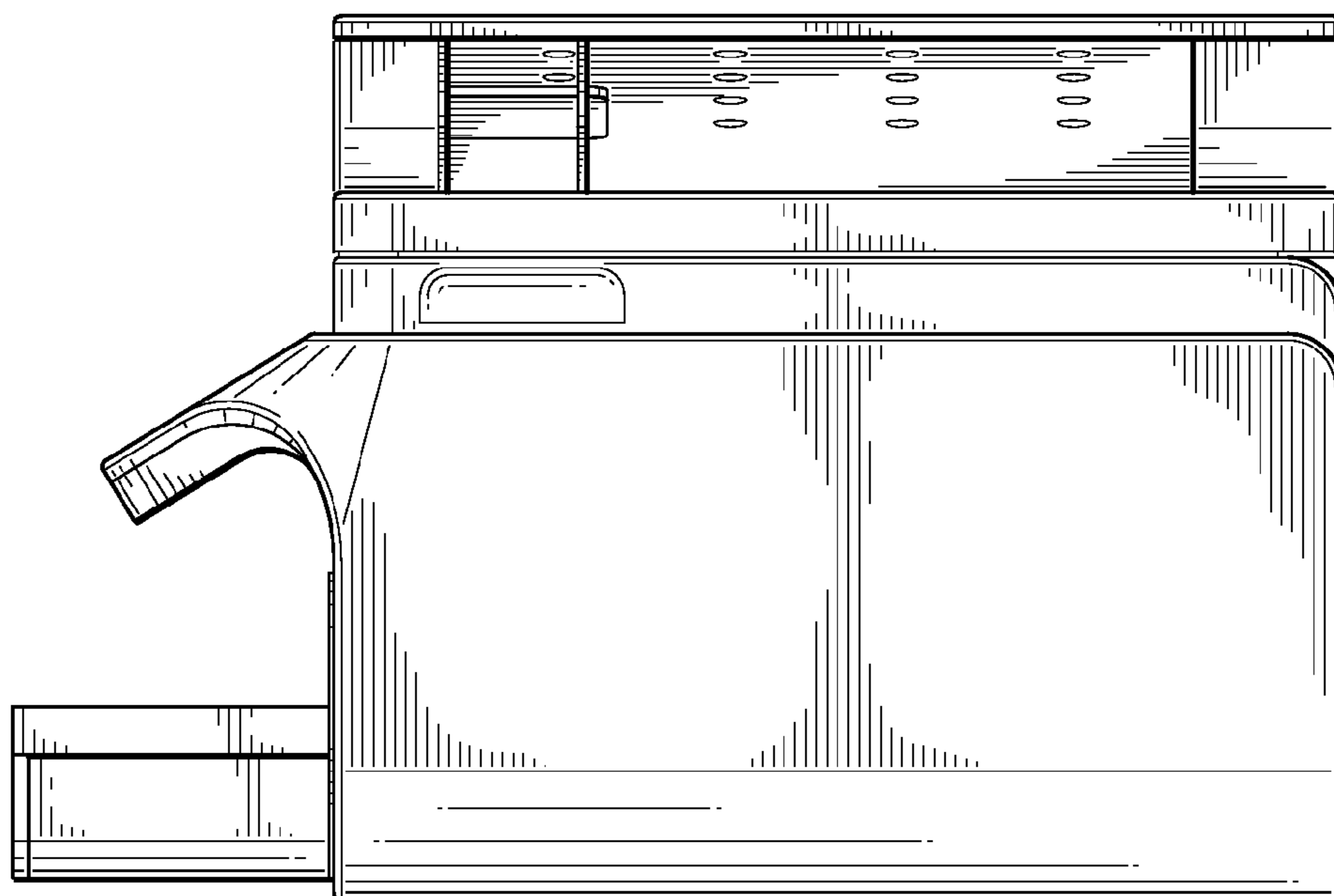
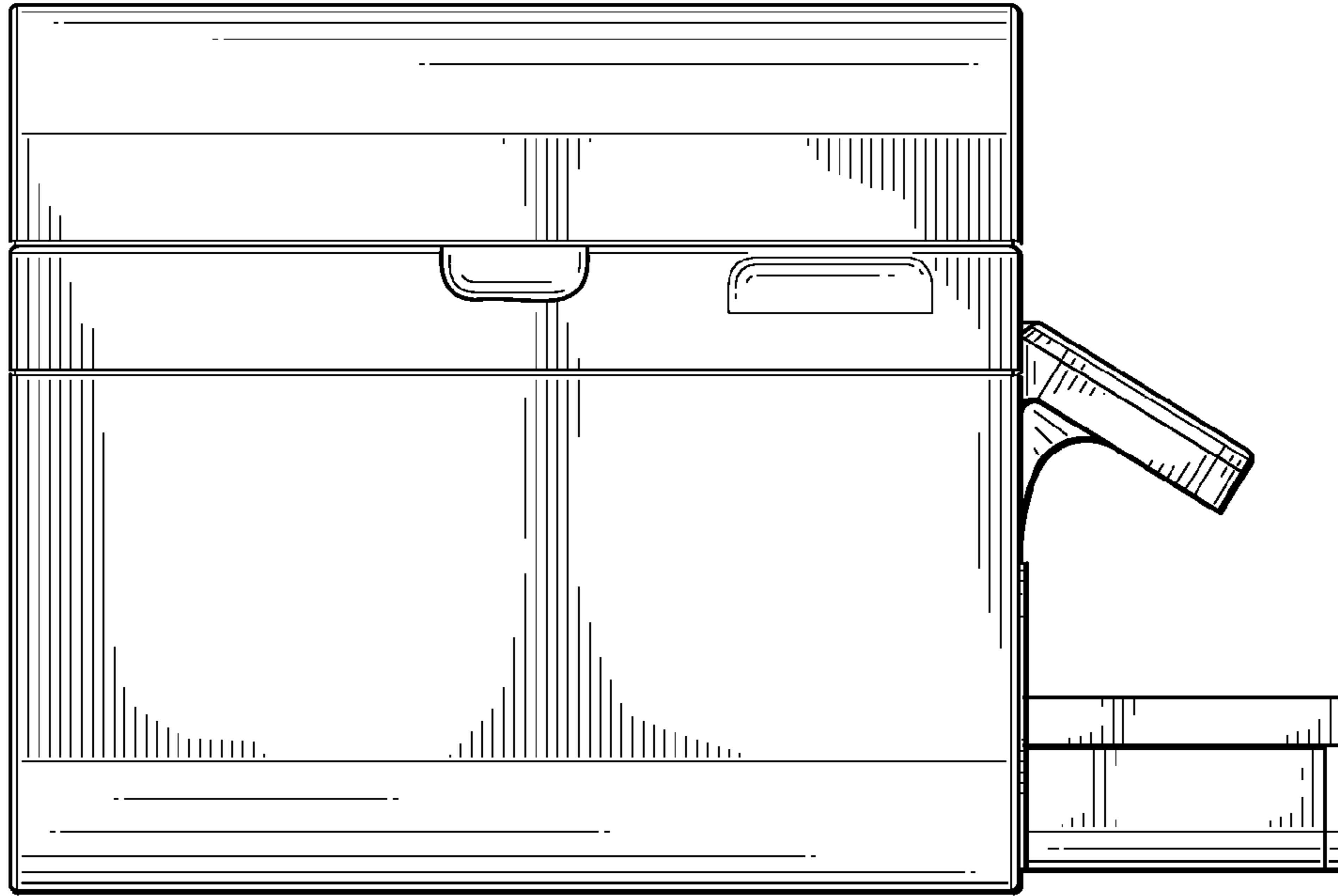
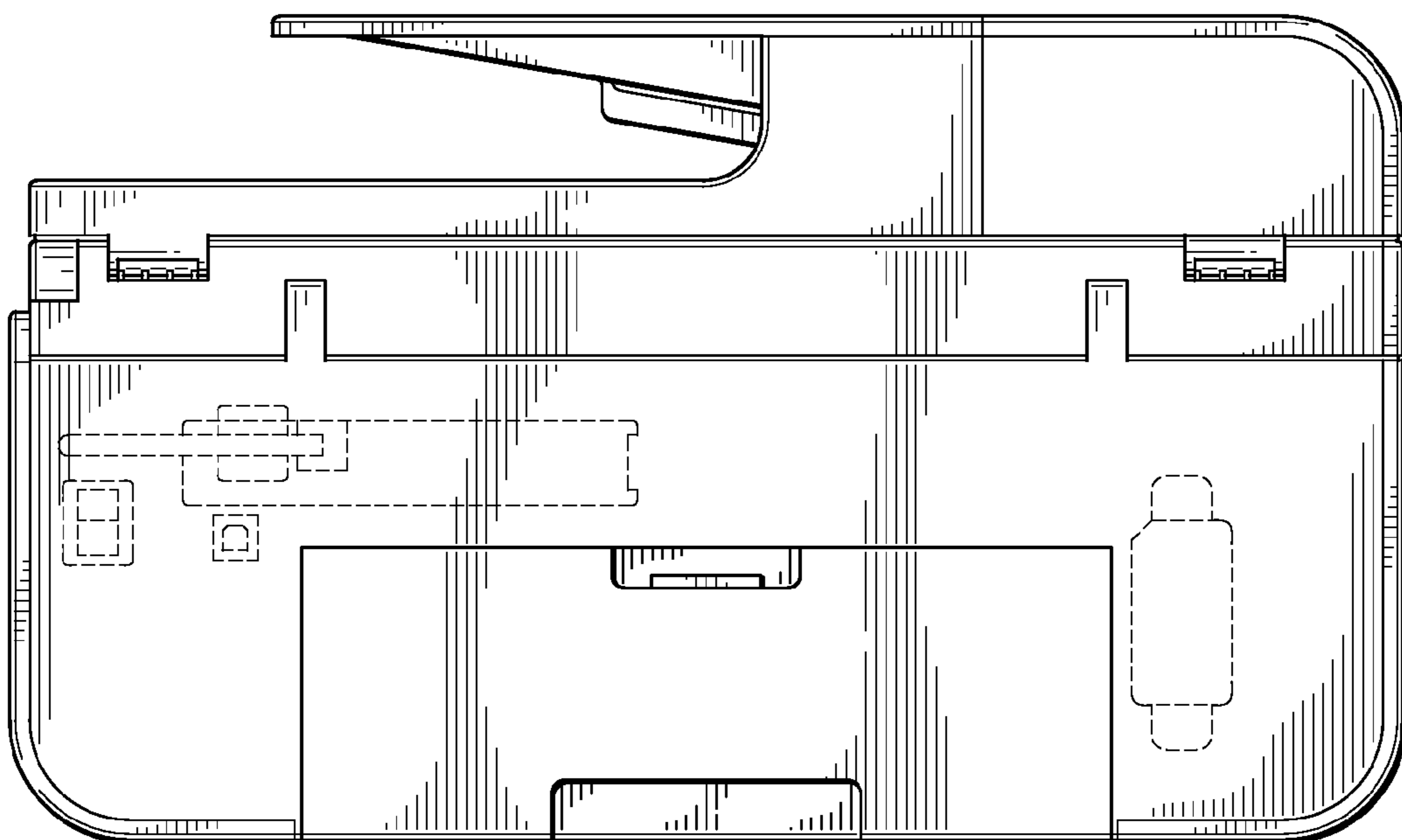

FIG. 3



*FIG. 4*



*FIG. 5*

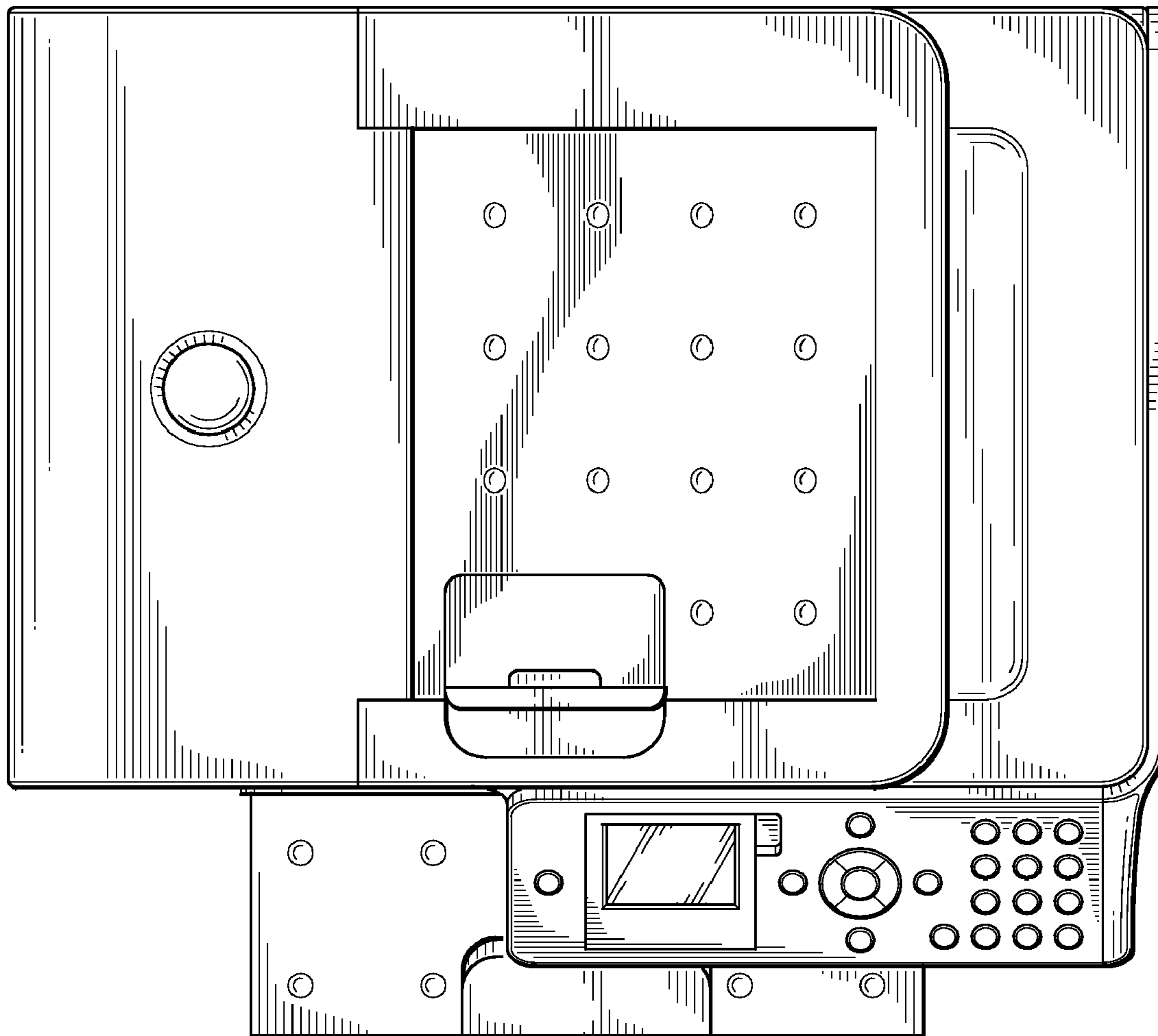

FIG. 6