



US00D555088S

(12) **United States Design Patent**
Ohmi

(10) **Patent No.:** **US D555,088 S**

(45) **Date of Patent:** **** Nov. 13, 2007**

(54) **DC TO AC POWER INVERTER FOR A VEHICLE ELECTRICAL SYSTEM**

(75) Inventor: **Hideaki Ohmi**, Kariya (JP)

(73) Assignee: **Kabushiki Kaisha Toyota Jidoshokki**, Kariya-shi (JP)

(**) Term: **14 Years**

(21) Appl. No.: **29/241,293**

(22) Filed: **Oct. 25, 2005**

(30) **Foreign Application Priority Data**

Apr. 26, 2005 (JP) 2005-012451
Apr. 26, 2005 (JP) 2005-012452

(51) **LOC (8) Cl.** **13-02**

(52) **U.S. Cl.** **D13/110**

(58) **Field of Classification Search** D13/110,
D13/123, 184, 199; 337/186; 361/600,
361/601, 730; 363/141, 142

See application file for complete search history.

(56) **References Cited**

U.S. PATENT DOCUMENTS

4,872,102 A * 10/1989 Getter 363/141
5,170,336 A * 12/1992 Getter et al. 363/141
D349,682 S * 8/1994 Hunziker D13/110
D413,567 S * 9/1999 Person et al. D13/110

5,949,640 A * 9/1999 Cameron et al. 361/600
D426,810 S * 6/2000 Wei D13/110
D427,146 S * 6/2000 Wei D13/110
D427,147 S * 6/2000 Wei D13/110
D427,148 S * 6/2000 Wei D13/110

* cited by examiner

Primary Examiner—Prabhakar Deshmukh

Assistant Examiner—Derrick Holland

(74) *Attorney, Agent, or Firm*—Morgan & Finnegan, L.L.P.

(57) **CLAIM**

The ornamental design for a DC to AC power inverter for a vehicle electrical system, as shown and described.

DESCRIPTION

FIG. 1 is a front perspective view of a DC to AC power inverter for a vehicle electrical system showing my new design;

FIG. 2 is a rear perspective view thereof;

FIG. 3 is a front view thereof;

FIG. 4 is a rear view thereof;

FIG. 5 is a top plan view thereof;

FIG. 6 is a bottom plan view thereof;

FIG. 7 is a right side elevational view thereof; and,

FIG. 8 is a left side elevational view thereof.

1 Claim, 6 Drawing Sheets

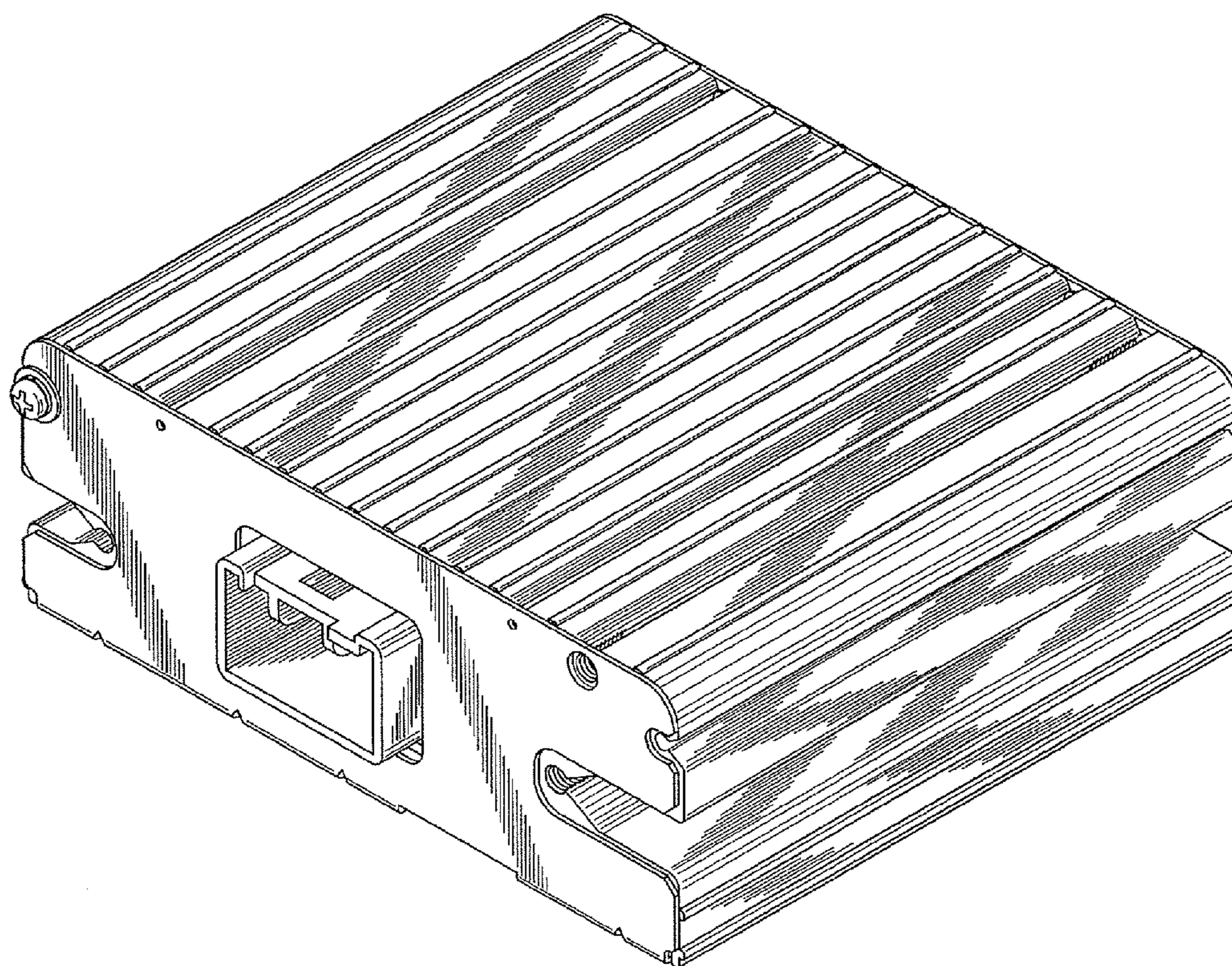

FIG. 1

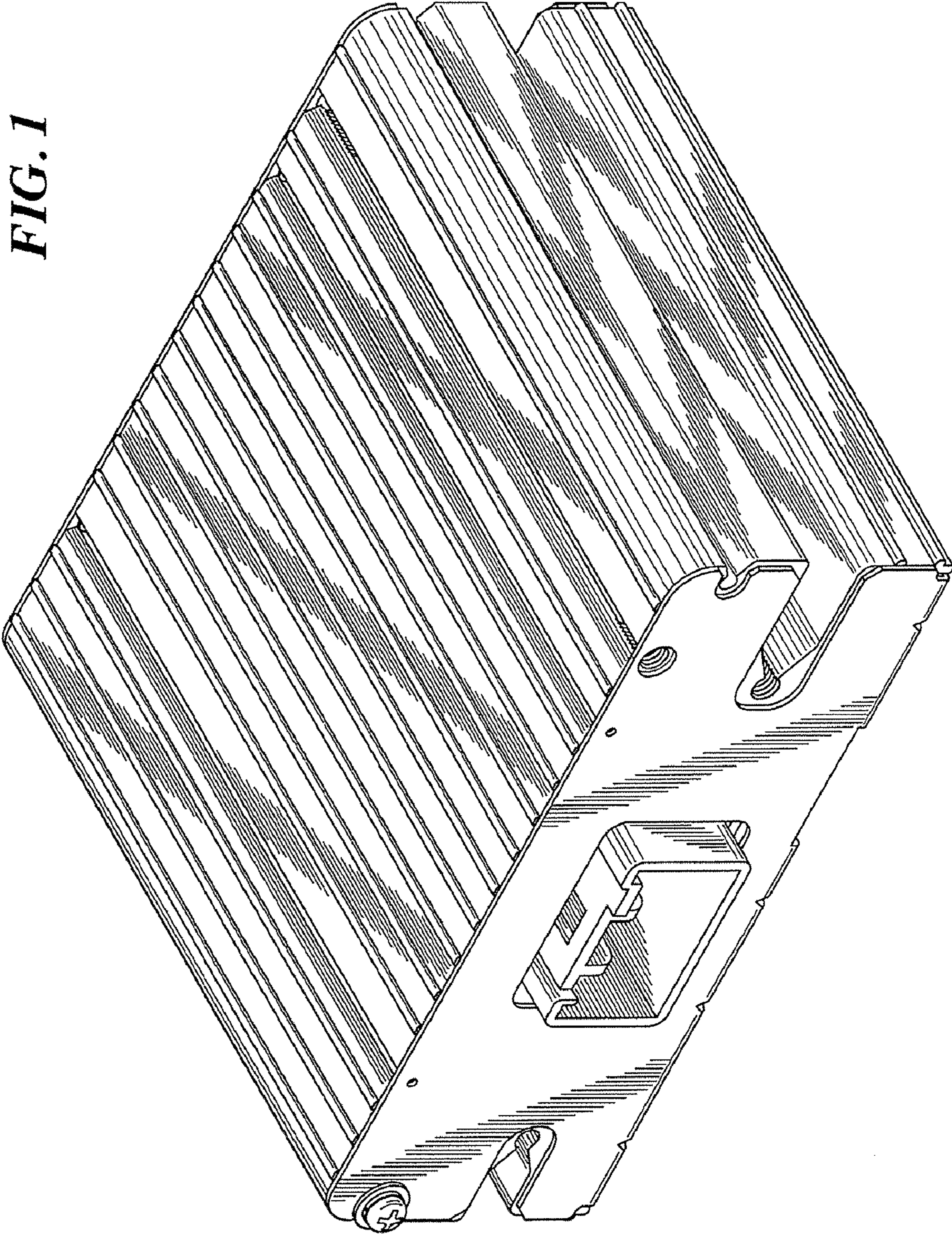

FIG. 2

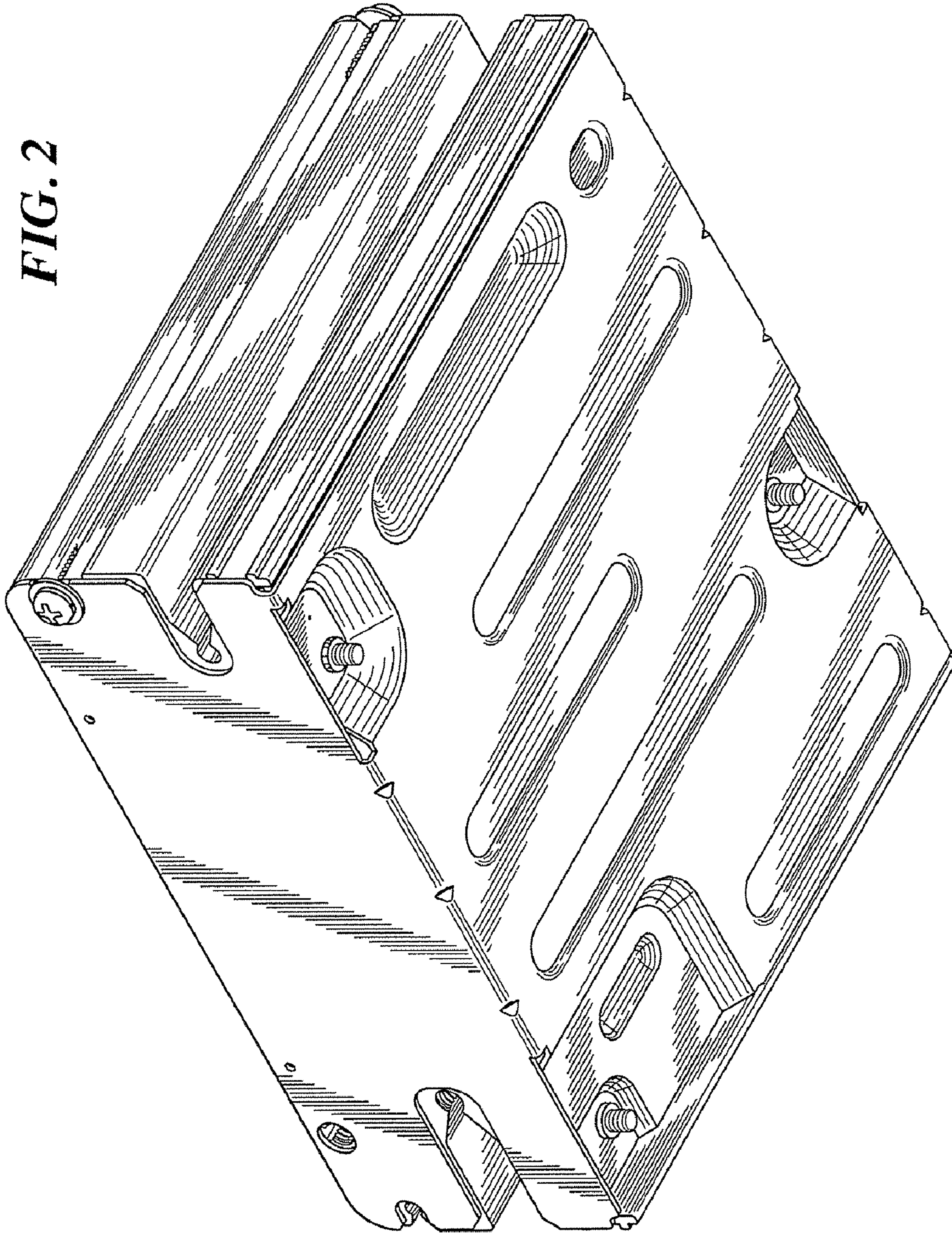

FIG. 3

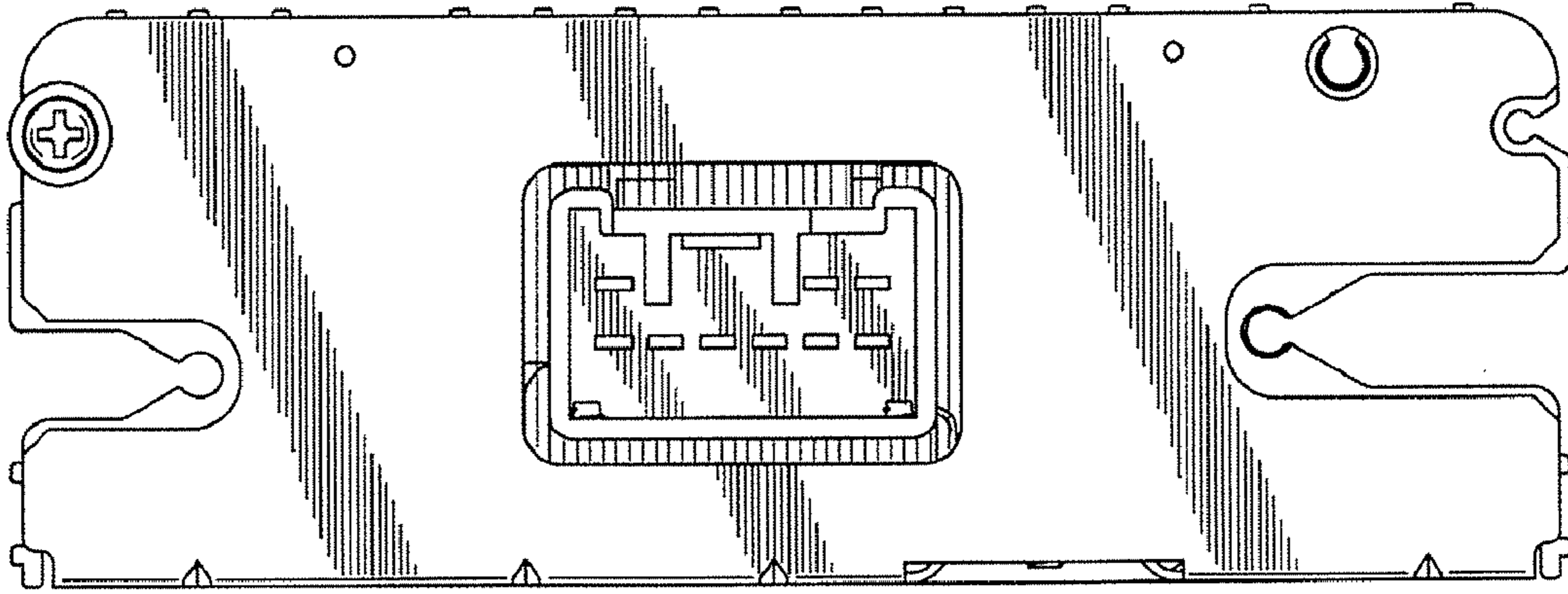

FIG. 4

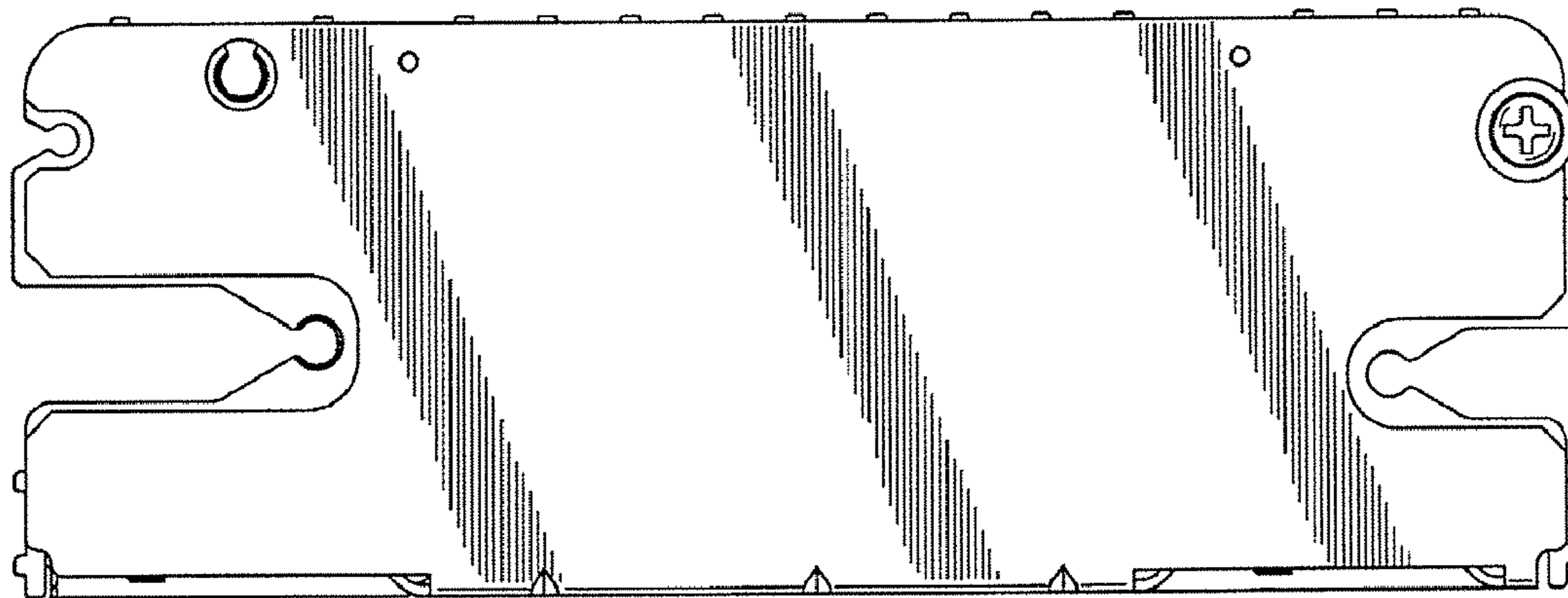

FIG. 5

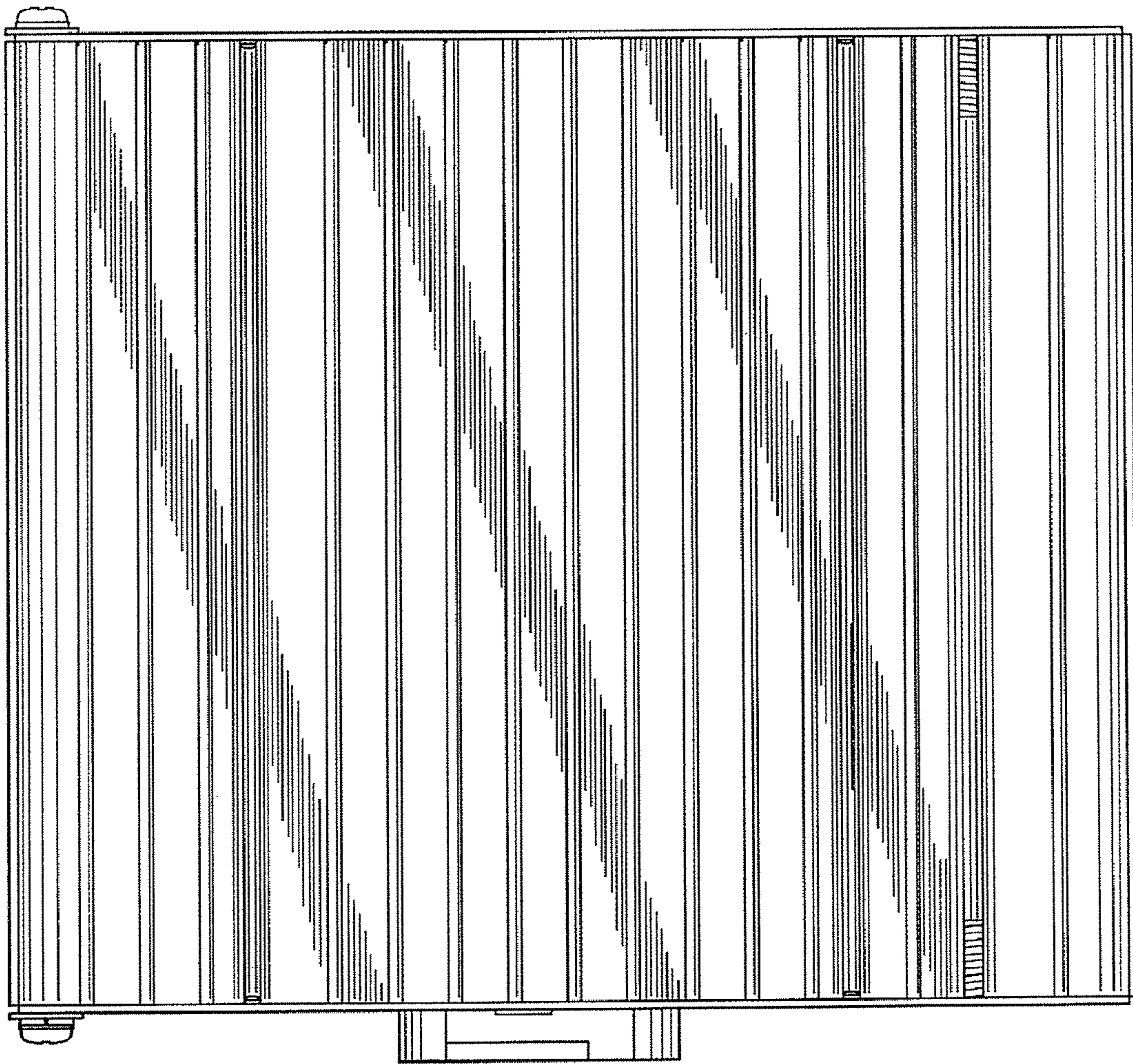

FIG. 6

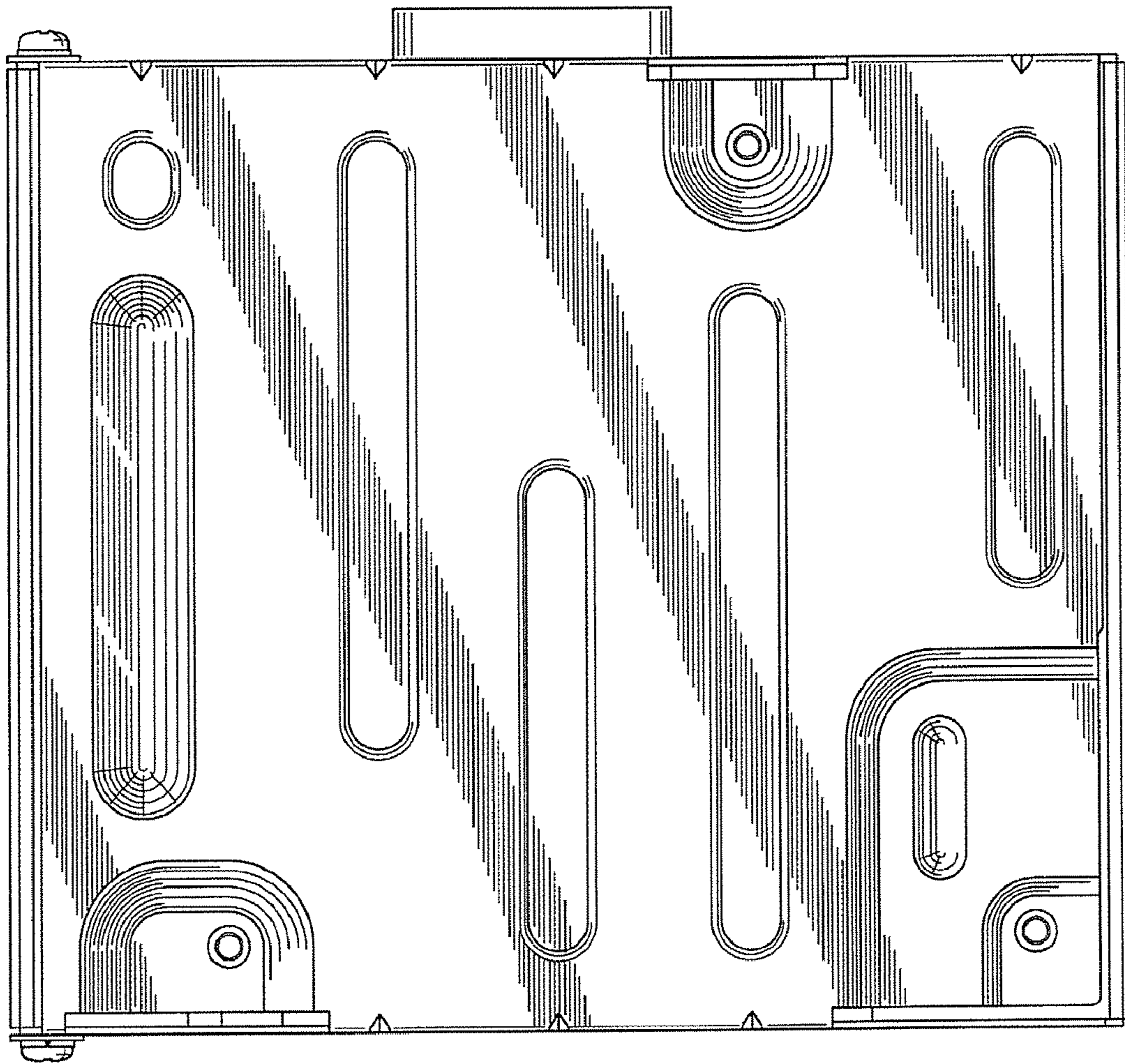

FIG. 7

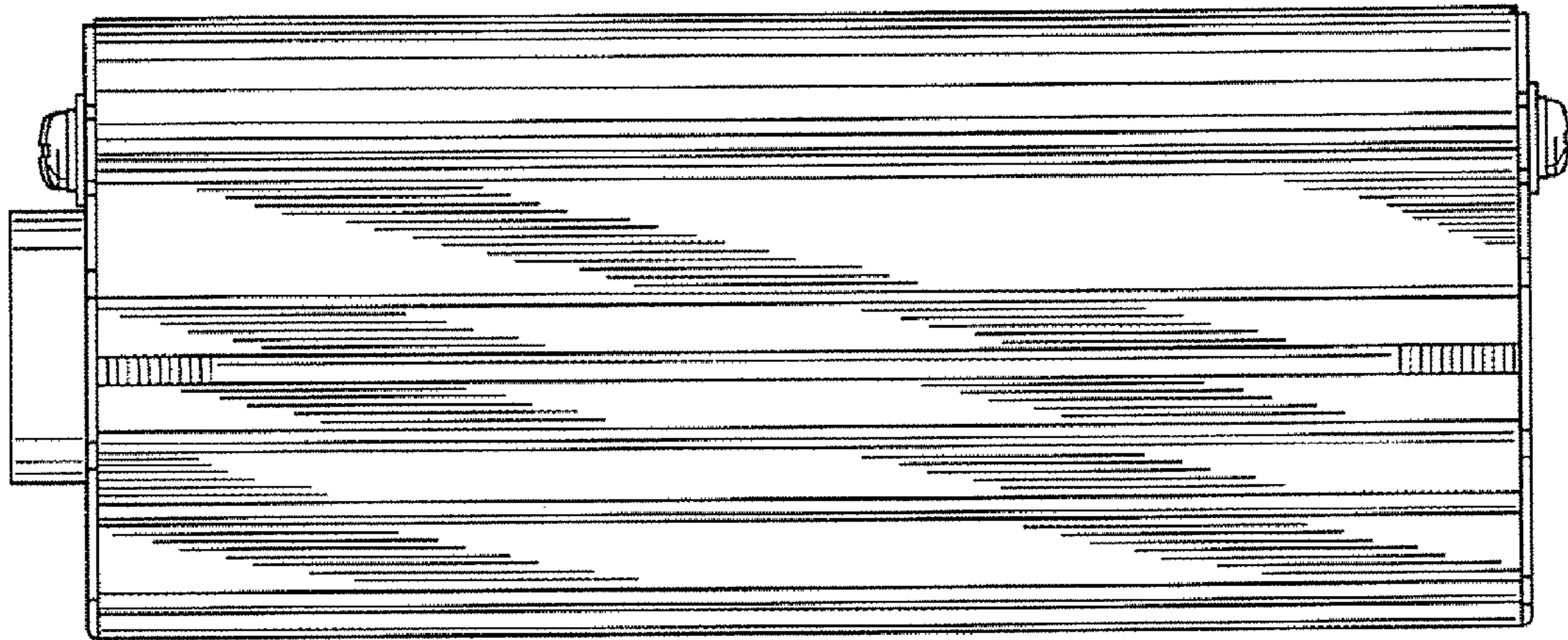

FIG. 8

