



US00D555058S

(12) **United States Design Patent**
Curtis, Jr. et al.

(10) **Patent No.:** **US D555,058 S**

(45) **Date of Patent:** **** Nov. 13, 2007**

(54) **DOOR FOR UTILITY VEHICLE**

(75) Inventors: **Fred Curtis, Jr.**, Princeton, MA (US);
Gary Orrell, Milbury, MA (US)

(73) Assignee: **Curtis Industries LLC**, Worcester, MA (US)

(**) Term: **14 Years**

(21) Appl. No.: **29/223,046**

(22) Filed: **Feb. 8, 2005**

(51) **LOC (8) Cl.** **12-16**

(52) **U.S. Cl.** **D12/196**

(58) **Field of Classification Search** D12/196,
D12/90-92, 86, 1, 14, 15, 82; 296/50, 155,
296/146.1, 146.11, 146.12

See application file for complete search history.

(56) **References Cited**

U.S. PATENT DOCUMENTS

2,460,399 A	2/1949	Schassberger	296/148
2,682,427 A	6/1954	Bright	296/148
3,387,406 A	6/1968	Coker et al.	296/50
3,454,299 A	7/1969	Hewitt et al.	296/50
3,567,274 A	3/1971	Kaptur et al.	296/50
3,592,504 A	7/1971	Sandor	296/70
3,623,764 A	11/1971	Jacobus	296/50
3,747,273 A	7/1973	Johnson	49/394
4,076,301 A	2/1978	Gergoe	296/57.1
4,299,058 A	11/1981	Spaulding	49/386
4,335,911 A	6/1982	Taylor	292/262
4,372,603 A	2/1983	Stanczak et al.	296/146.12
4,437,410 A	3/1984	Stoller et al.	105/378
4,621,859 A	11/1986	Spicher	296/78.1
4,773,694 A	9/1988	Gerber	296/77.1
4,929,004 A	5/1990	Chidester	292/267
4,932,714 A	6/1990	Chance	296/148
5,004,286 A	4/1991	Taylor et al.	296/24.46
5,203,601 A	4/1993	Guillot	296/77.1
5,217,275 A	6/1993	Ridge	296/77.1
5,259,656 A	11/1993	Carroll	296/77.1
5,276,745 A	1/1994	Revelli, Jr.	385/14
5,310,235 A	5/1994	Seymour et al.	296/77.1

D349,265 S *	8/1994	Patton	D12/14
5,388,881 A	2/1995	Spencer et al.	296/77.1
5,393,118 A	2/1995	Welborn	296/147
5,404,618 A	4/1995	Heiler et al.	16/261
5,429,404 A	7/1995	King, Sr. et al.	296/79
D363,265 S	10/1995	Althoff	D12/16
5,529,369 A	6/1996	Welborn	296/77.1
5,544,449 A	8/1996	Amelio et al.	49/383
5,588,690 A	12/1996	Showalter	296/77.1
5,632,065 A	5/1997	Siladke et al.	16/335
5,685,594 A	11/1997	Harper	296/51
D413,283 S	8/1999	Stepp et al.	D12/16
6,030,024 A	2/2000	Schmidhuber et al.	296/146.12

(Continued)

Primary Examiner—Melody N. Brown

(74) *Attorney, Agent, or Firm*—Niels & Lemack

(57) **CLAIM**

The ornamental design for a door for utility vehicle, as shown and described.

DESCRIPTION

FIG. 1 is a perspective view of the door for utility vehicle of the present invention;

FIG. 2 is a front view of the door of the present invention;

FIG. 3 is a side view of the door of the present invention;

FIG. 4 is an opposite side view of the door of the present invention;

FIG. 5 is a top view of the door of the present invention;

FIG. 6 is a bottom view of the door of the present invention;

FIG. 7 is a perspective view of the door of the present invention in an open position on a golf cart; and,

FIG. 8 is a perspective view of the door of the present invention in a closed position on a golf cart.

The broken lines shown in the FIGS. 7 and 8 drawings views are for illustrative purposes only and form no part of the claimed design.

1 Claim, 4 Drawing Sheets

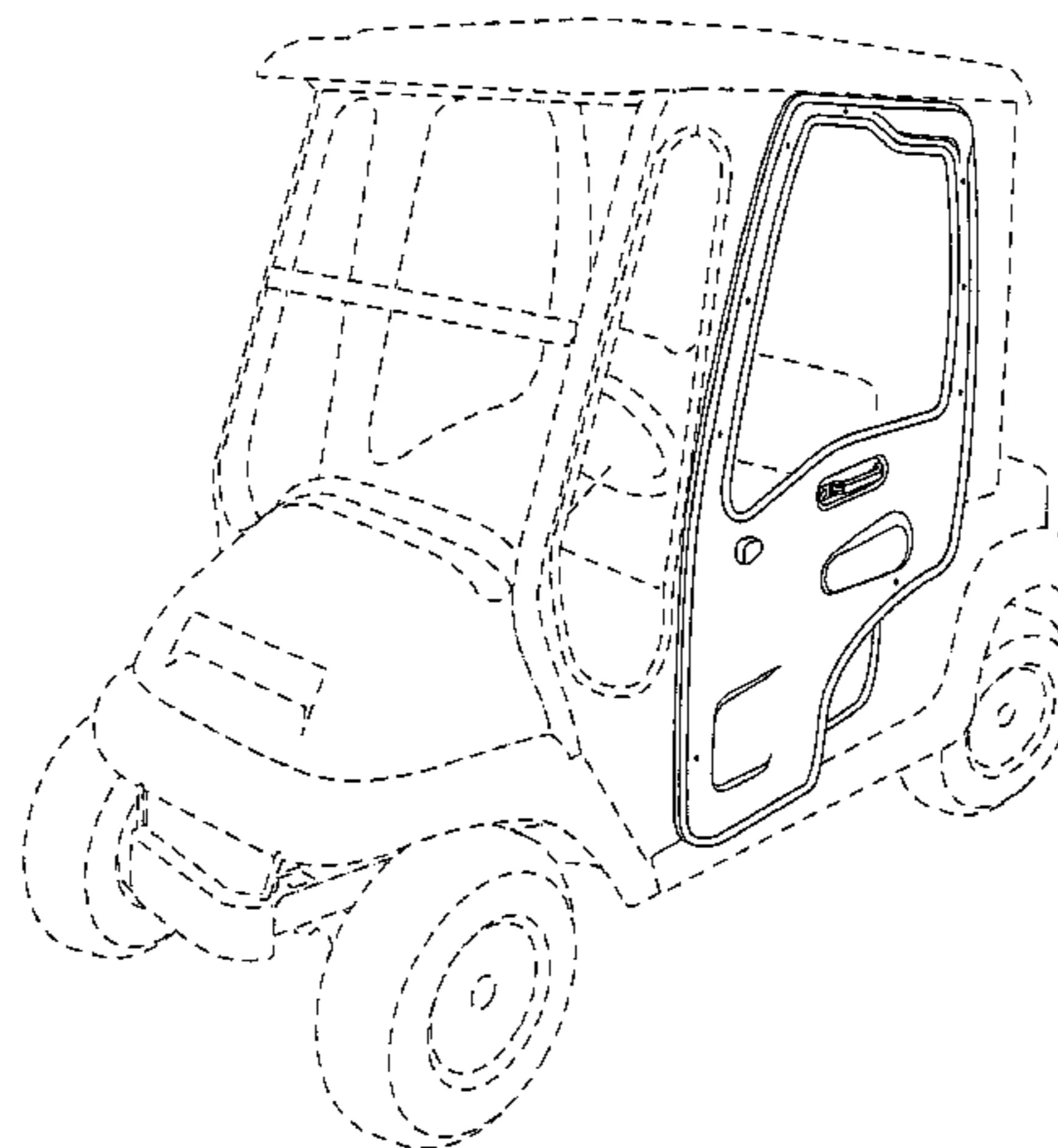

US D555,058 S

Page 2

U.S. PATENT DOCUMENTS

6,158,801 A	12/2000	Tucker	296/146.1	D498,704 S	11/2004	Bonner et al.	D12/16
6,161,336 A	12/2000	Ziv-Av	49/260	6,827,390 B2	12/2004	Zummallen et al. ...	296/146.11
6,213,535 B1	4/2001	Landmesser et al. ..	296/146.12	D508,004 S *	8/2005	Metros et al.	D12/196
6,276,745 B1	8/2001	Wilson	296/155	6,926,342 B2 *	8/2005	Pommeret et al.	296/155
6,293,610 B1	9/2001	Howard	296/148	6,942,277 B2	9/2005	Rangnekar et al.	296/146.11
6,382,705 B1	5/2002	Lang et al.	296/155	D515,458 S	2/2006	Tolfsen et al.	D12/85
6,412,877 B1	7/2002	Faison	296/183.2	6,997,504 B1	2/2006	Lang et al.	296/146.12
6,439,637 B1	8/2002	Tyrer	296/79	7,070,225 B2	7/2006	Herrmann	296/146.6
6,547,304 B1	4/2003	Conner et al.	296/79	7,080,868 B2	7/2006	McClure et al.	296/146.11
6,658,803 B2	12/2003	Szykowski	52/213	7,096,538 B2	8/2006	Liang et al.	296/146.11
D490,579 S *	5/2004	Cunningham	D32/16	7,147,257 B2	12/2006	Johansen et al.	292/341.15
6,742,826 B2	6/2004	Humphrey et al.	296/51	7,150,486 B2	12/2006	Ichinose	296/51
6,748,776 B2	6/2004	Bullock et al.	70/212	7,165,800 B2	1/2007	Thiele et al.	296/57.1
6,764,130 B1	7/2004	Hull	296/186.4	2005/0110298 A1	5/2005	Fin et al.	296/146.5
6,773,055 B1	8/2004	Stoudt et al.	296/153	2005/0127712 A1	6/2005	Castillo	296/146.12
6,776,445 B1	8/2004	Conner et al.	296/79	2006/0087145 A1	4/2006	Curtis et al.	296/80
6,779,825 B1	8/2004	Greenert et al.	296/51	2006/0087149 A1	4/2006	Curtis et al.	296/146.1
D498,436 S	11/2004	Bonner et al.	D12/16	2006/0087150 A1	4/2006	Curtis et al.	296/146.1

* cited by examiner

FIG. 1

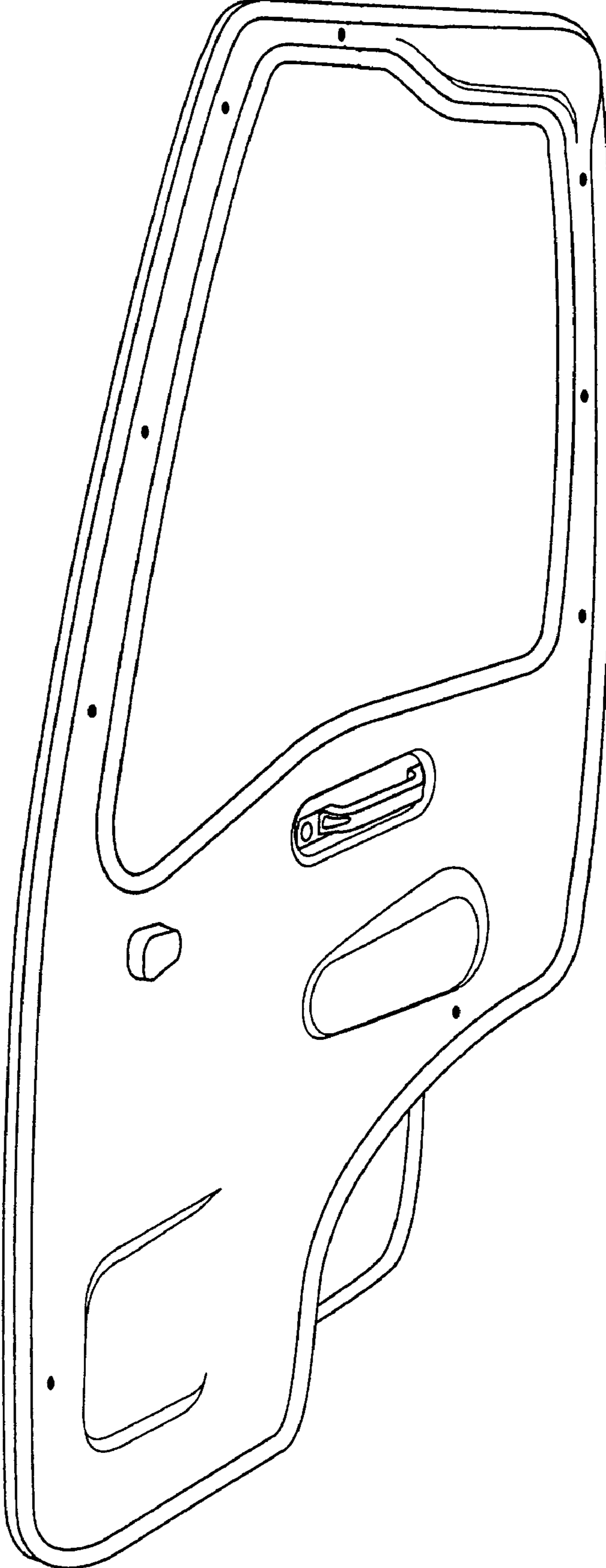

FIG. 5

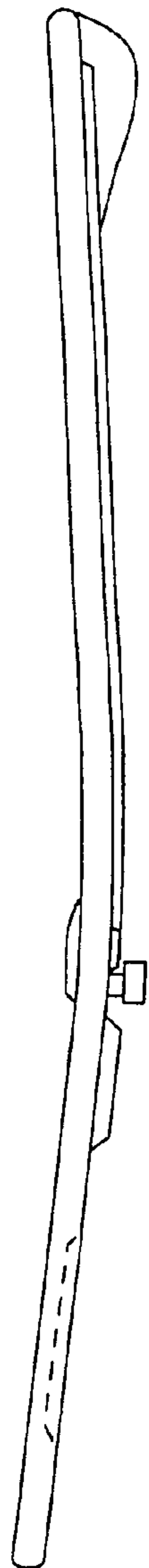
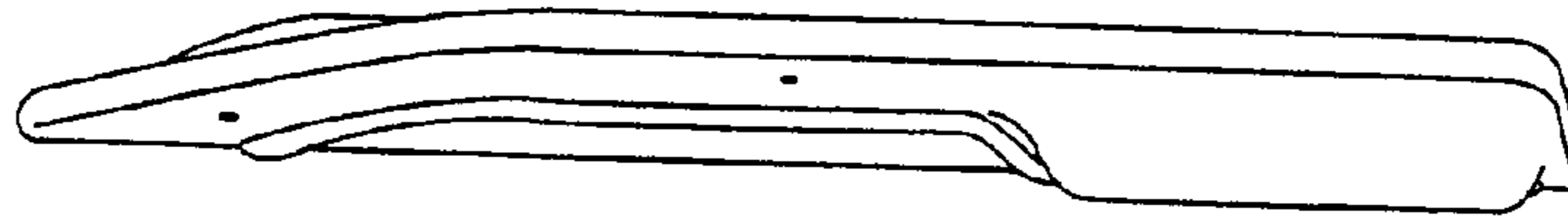

FIG. 3

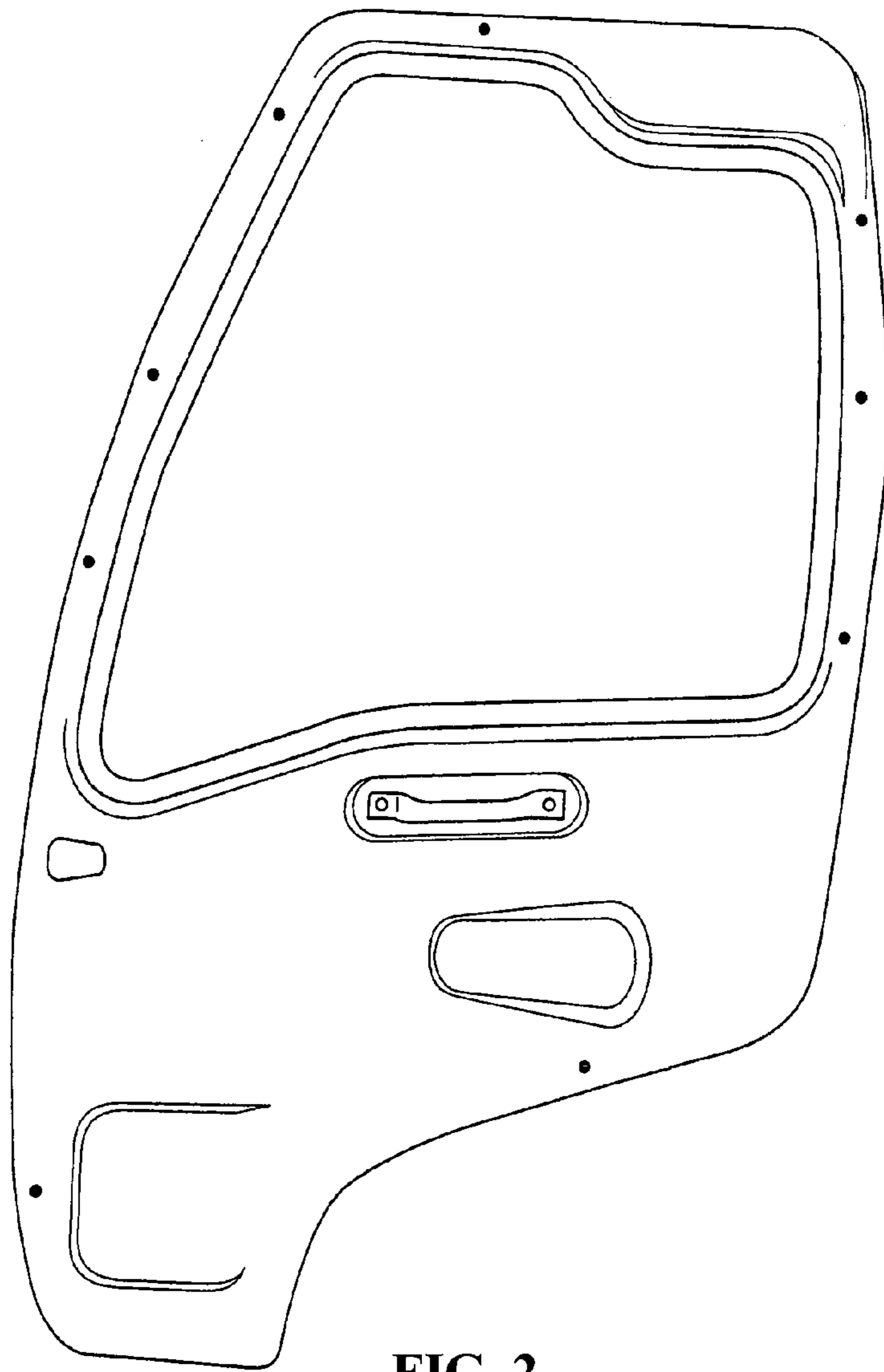

FIG. 2

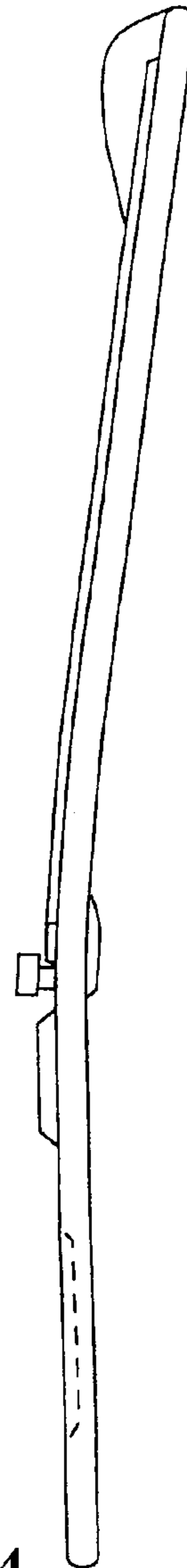

FIG. 4

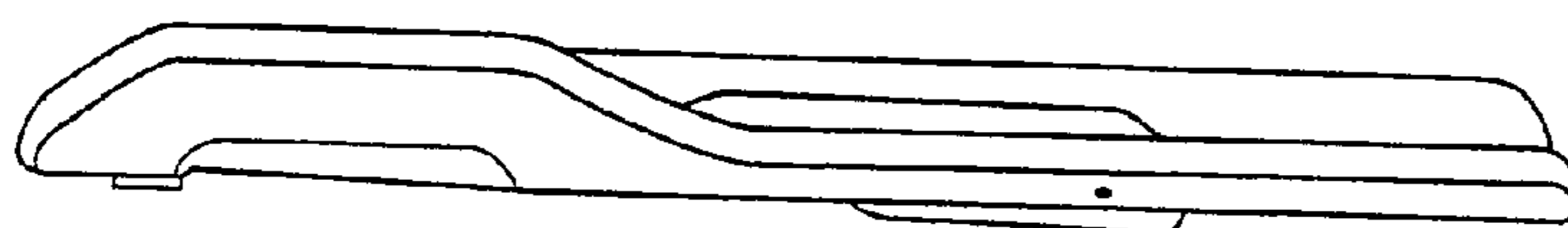

FIG. 6

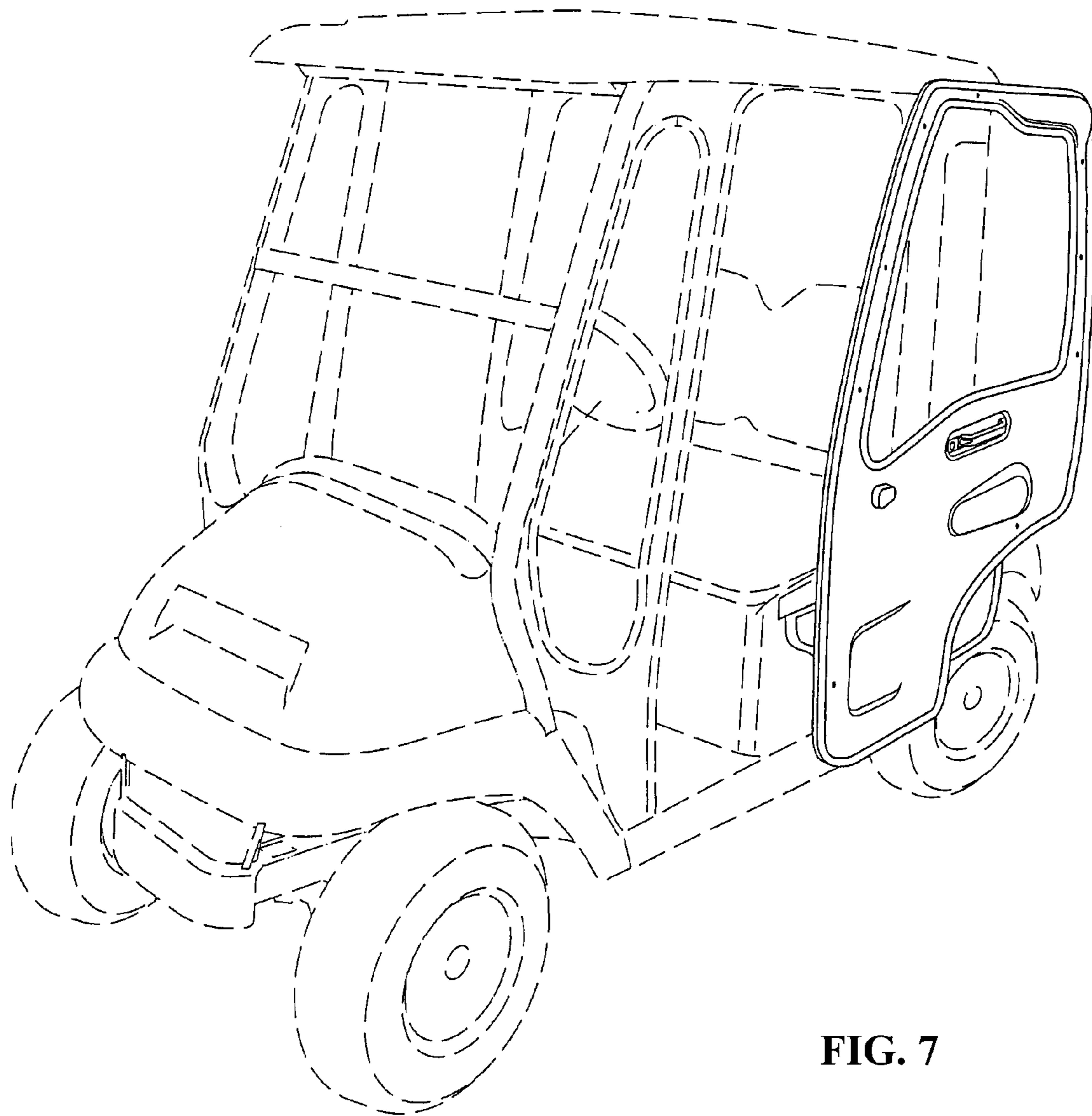

FIG. 7

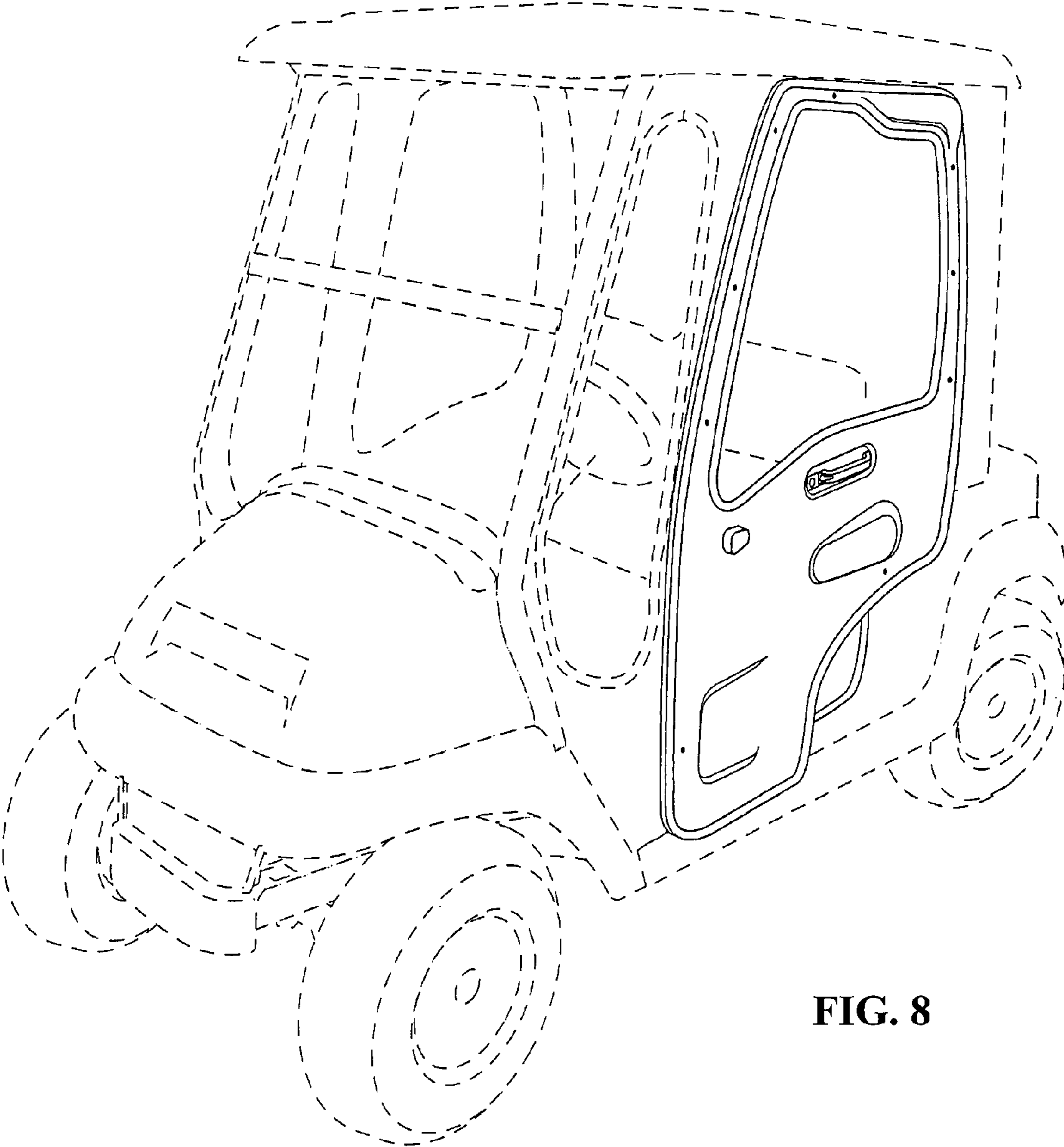

FIG. 8