



US00D555042S

(12) **United States Design Patent**
Davidson

(10) **Patent No.:** **US D555,042 S**

(45) **Date of Patent:** **** Nov. 13, 2007**

(54) **VEHICLE**

(75) Inventor: **Benjamin Ryan Davidson**, Redondo Beach, CA (US)

(73) Assignee: **Honda Motor Co., Ltd.**, Tokyo (JP)

(**) Term: **14 Years**

(21) Appl. No.: **29/250,663**

(22) Filed: **Nov. 27, 2006**

(51) **LOC (8) Cl.** **12-08**

(52) **U.S. Cl.** **D12/92**

(58) **Field of Classification Search** D12/90-92,
D12/86; D21/424, 433; 296/181.1
See application file for complete search history.

(56) **References Cited**

U.S. PATENT DOCUMENTS

D455,982 S *	4/2002	Iso et al.	D12/91
D457,835 S *	5/2002	Iso et al.	D12/91
D526,933 S *	8/2006	Schumacher	D12/92
D539,703 S *	4/2007	Woodhouse et al.	D12/92
D541,703 S *	5/2007	Mochizuki	D12/92

* cited by examiner

Primary Examiner—Melody N. Brown

(74) *Attorney, Agent, or Firm*—Plumsea Law Group, LLC

(57) **CLAIM**

The ornamental design for a vehicle, as shown and described.

DESCRIPTION

FIG. 1 is a front perspective view of a vehicle showing my new design;

FIG. 2 is a rear perspective view thereof;

FIG. 3 is a side elevational view, the opposite side elevational view being a mirror image thereof;

FIG. 4 is a front elevational view thereof;

FIG. 5 is a rear elevational view thereof;

FIG. 6 is a top plan view thereof;

FIG. 7 is a front perspective view of a second embodiment of a vehicle showing my new design;

FIG. 8 is a rear perspective view of FIG. 7;

FIG. 9 is a side elevational view, the opposite side elevational view of FIG. 7 being a mirror image of FIG. 7;

FIG. 10 is a front elevational view of FIG. 7;

FIG. 11 is a rear elevational view of FIG. 7; and,

FIG. 12 is a top plan view of FIG. 7.

In FIGS. 1-6, the broken line showings in the front grille and intake areas; the headlight and tail light interior elements; the wheels and tires; the rear view mirror; and the small elements in the side body panels are for illustrative purposes only and form no part of the claimed design.

1 Claim, 10 Drawing Sheets

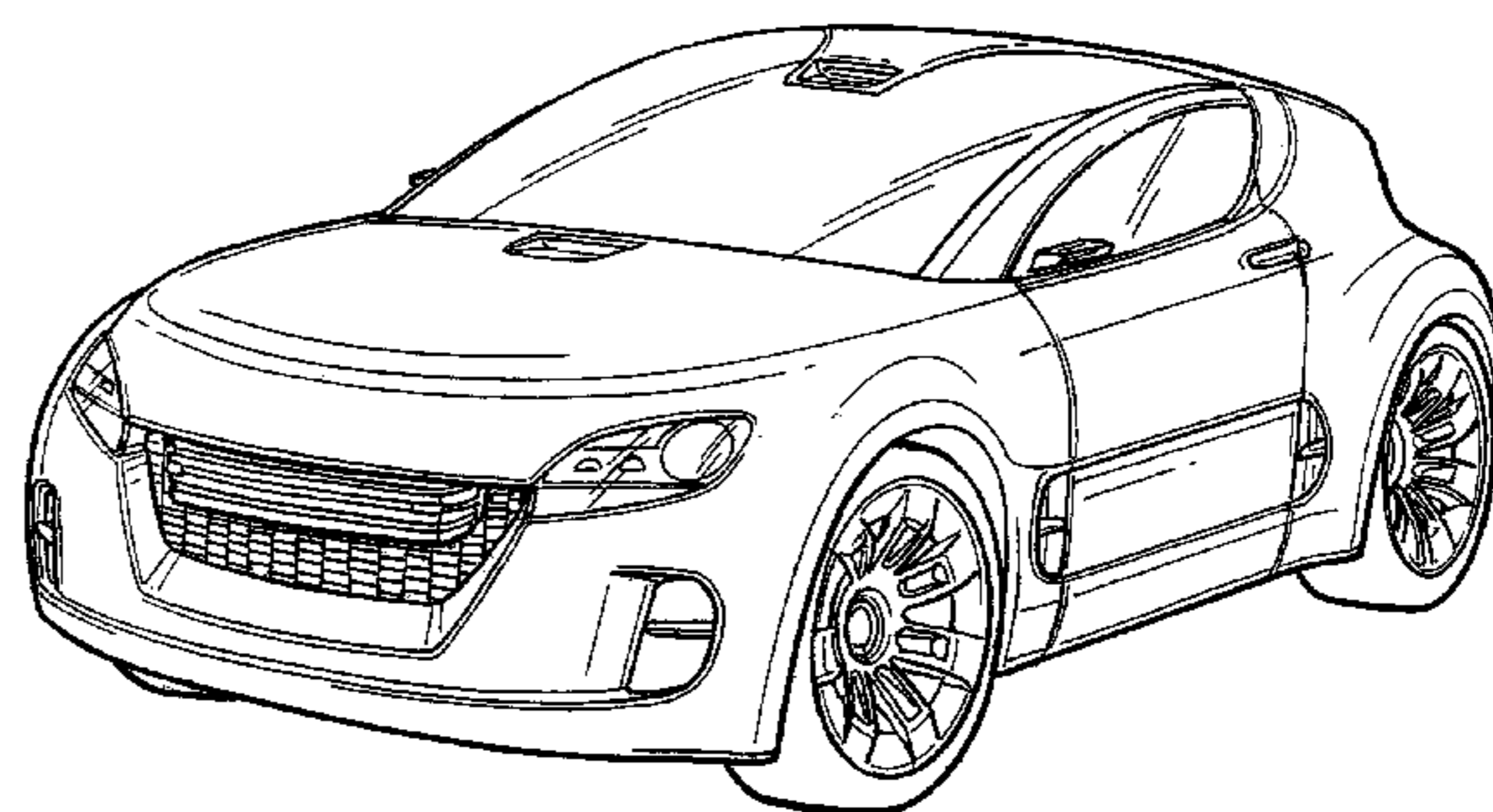
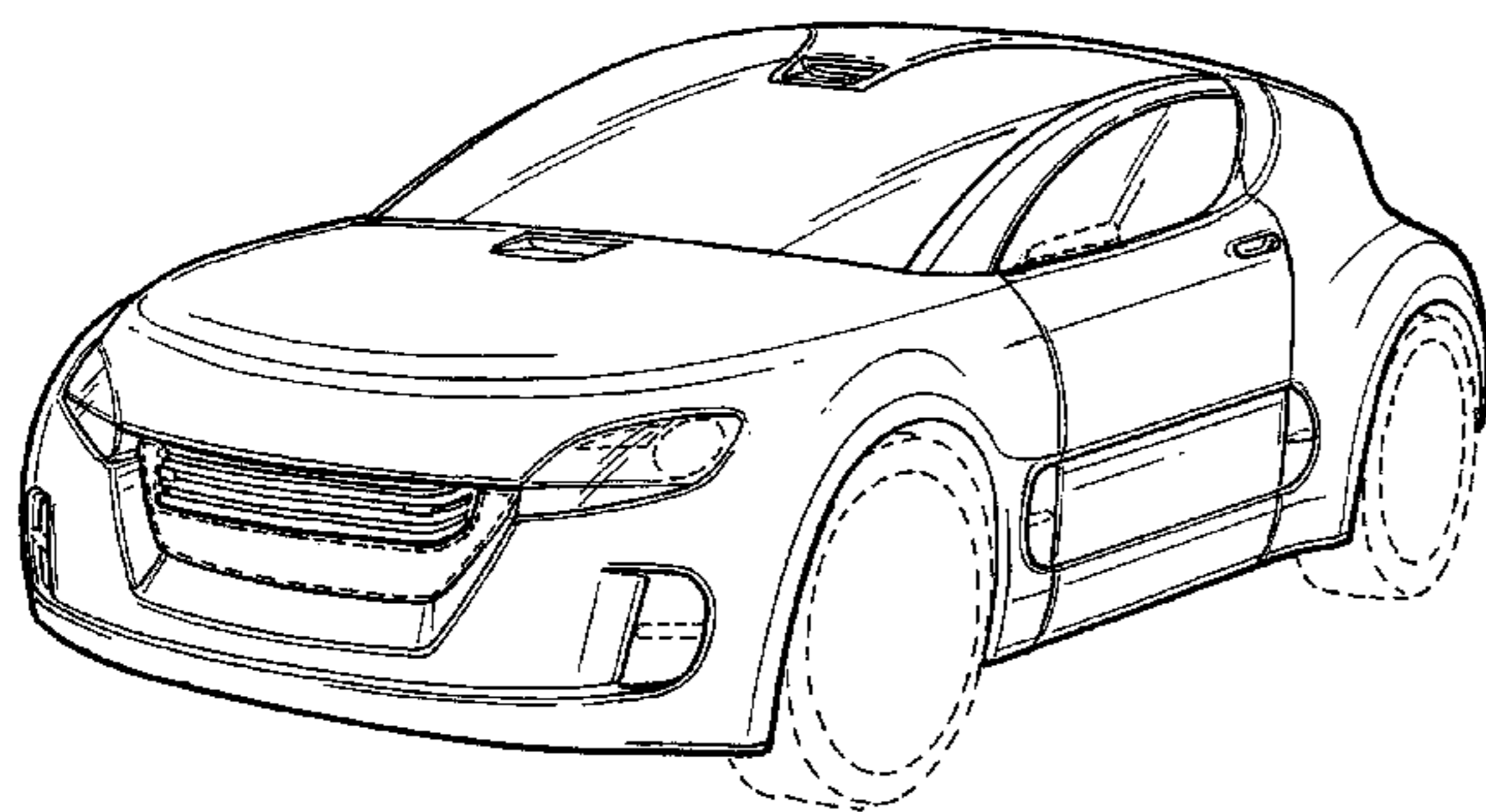

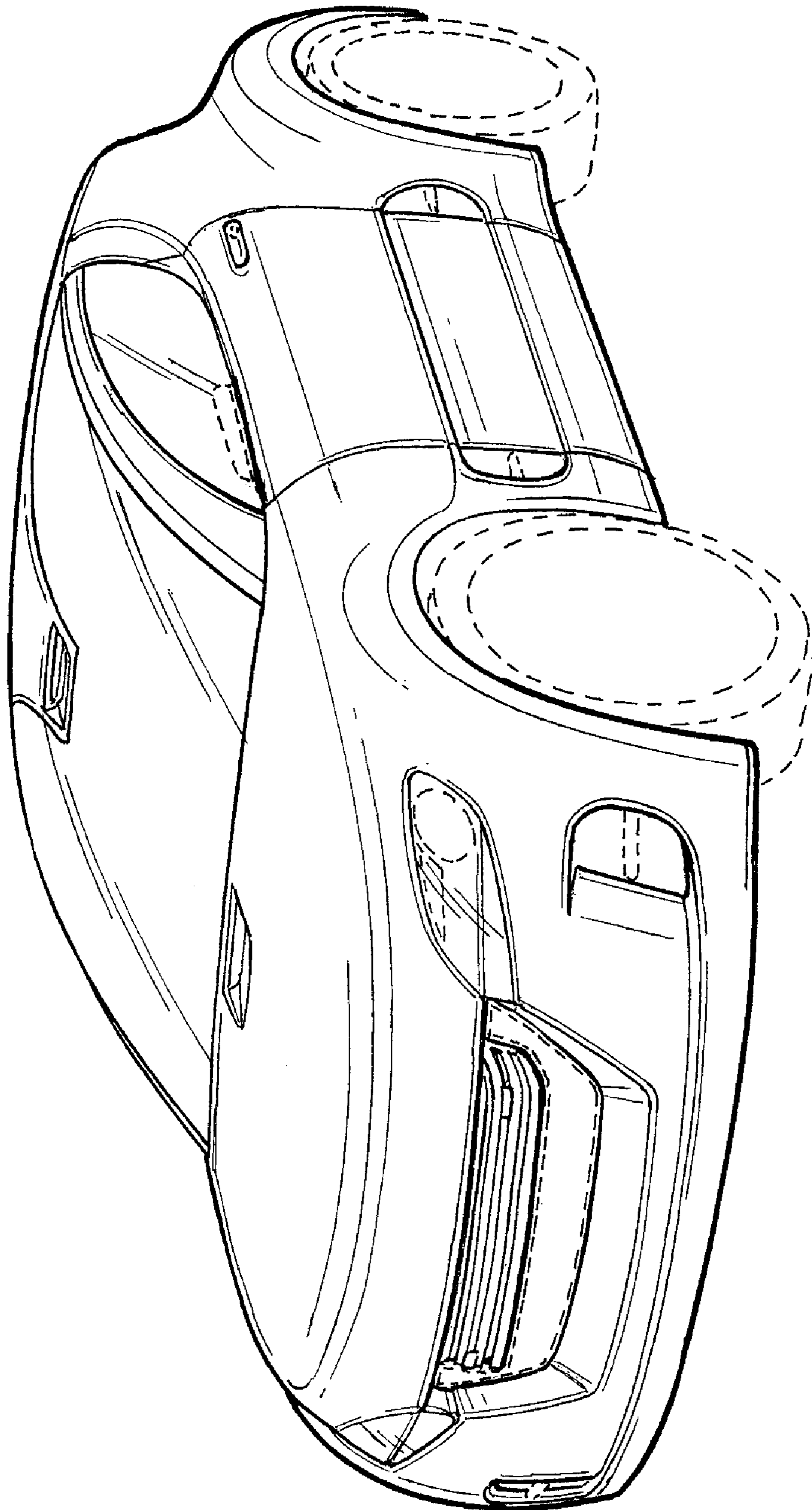

FIG. 1

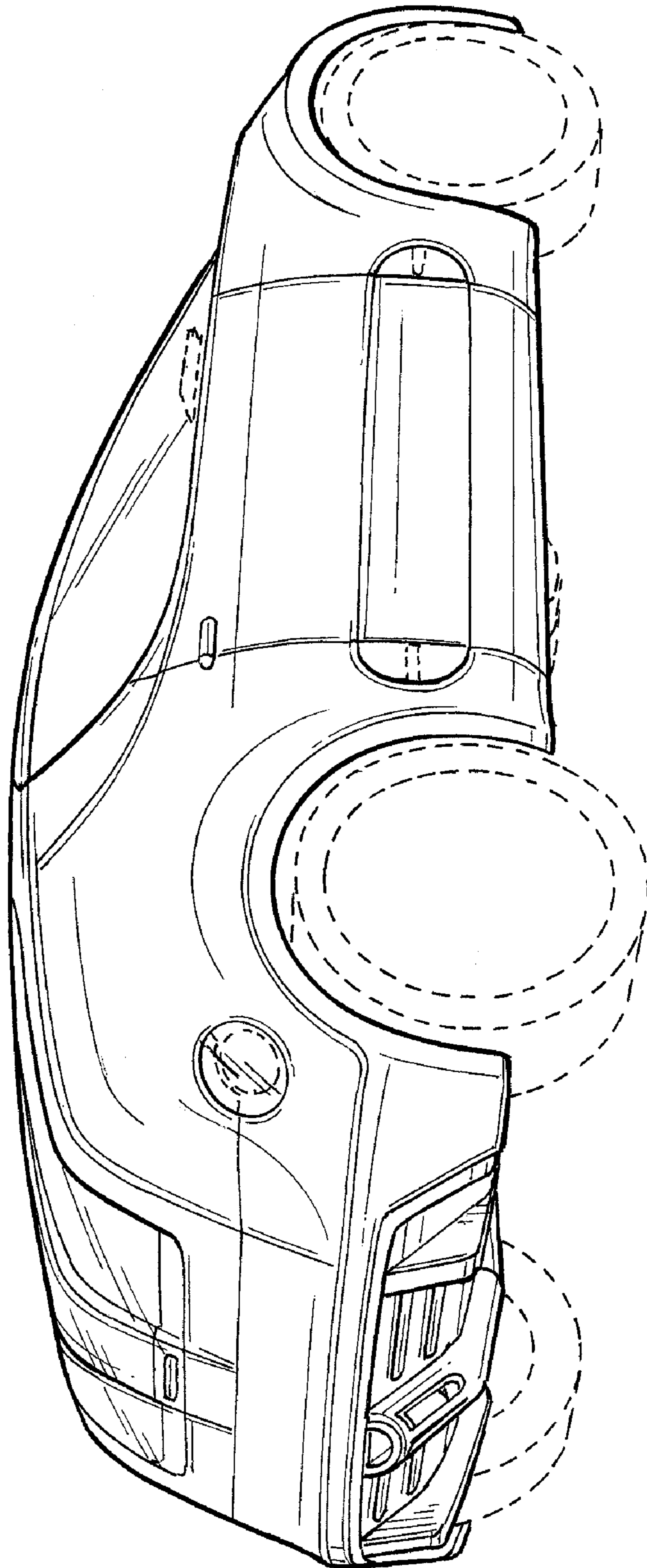

FIG. 2

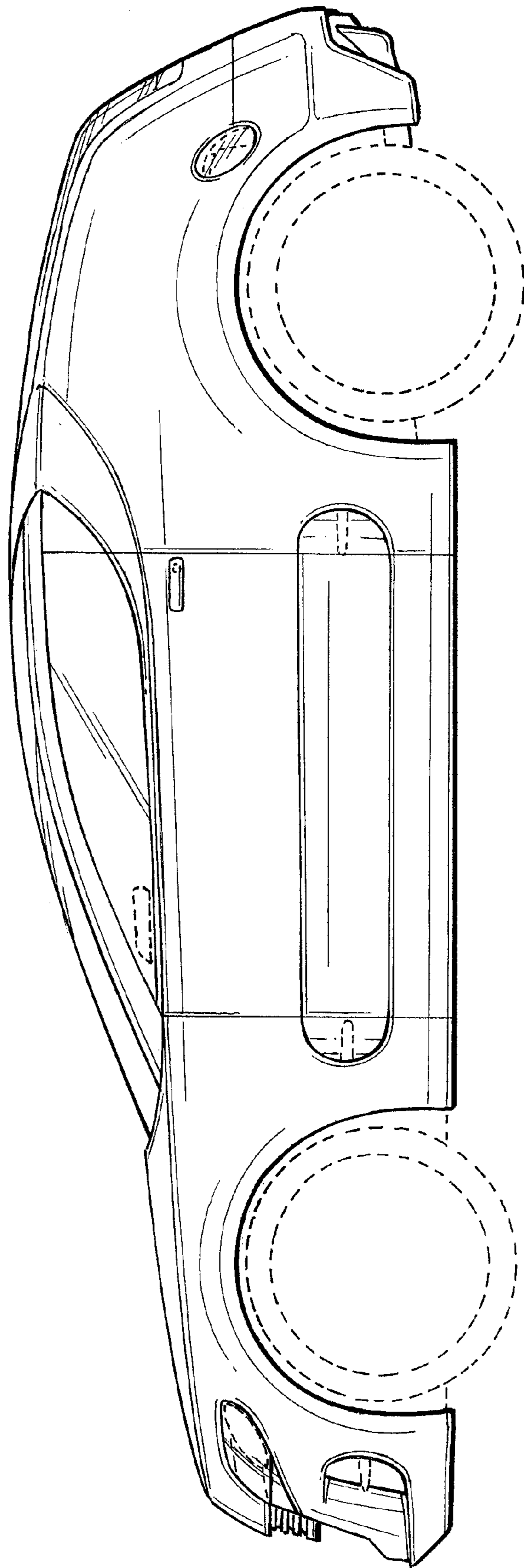

FIG. 3

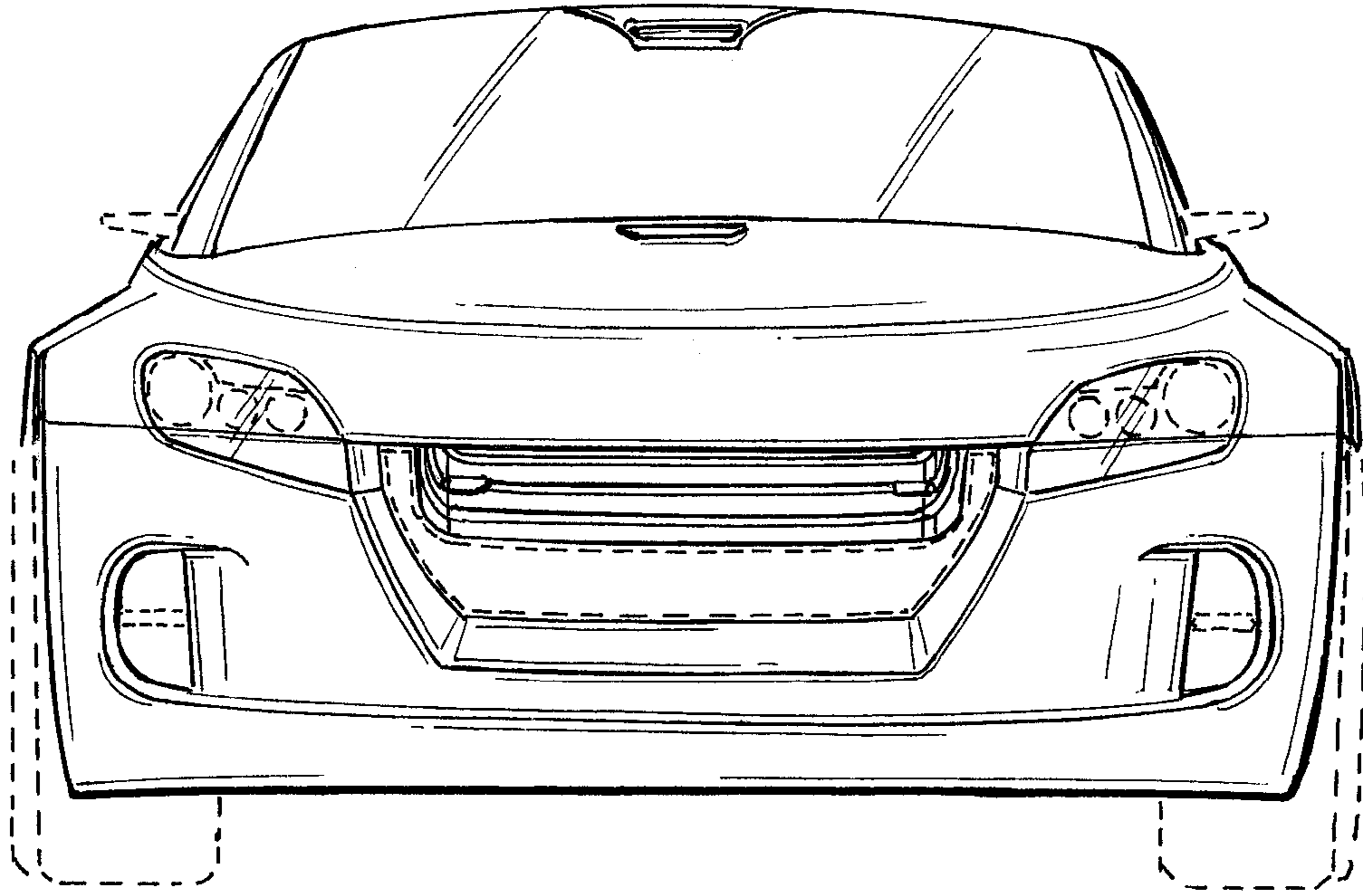

FIG. 4

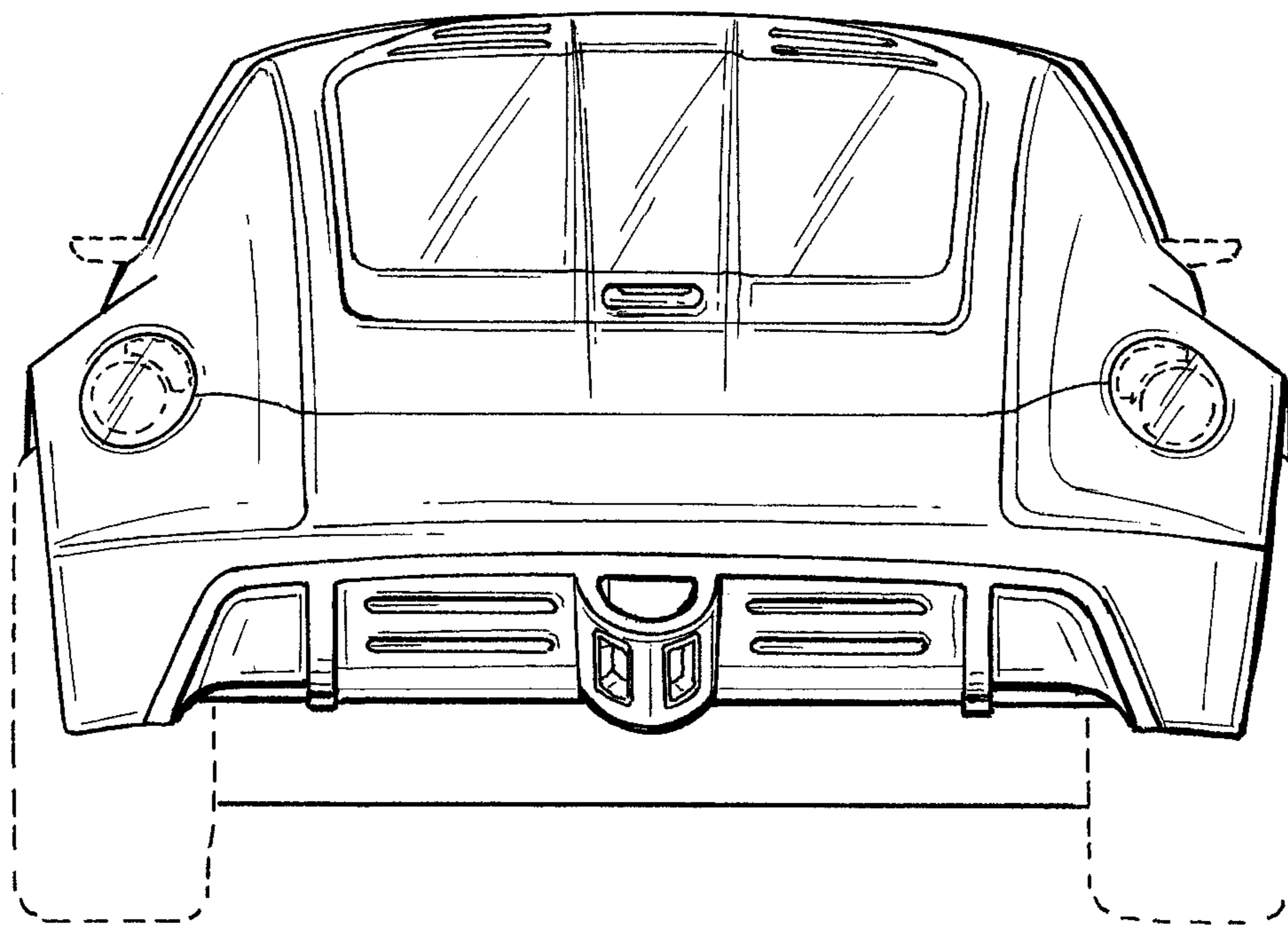

FIG. 5

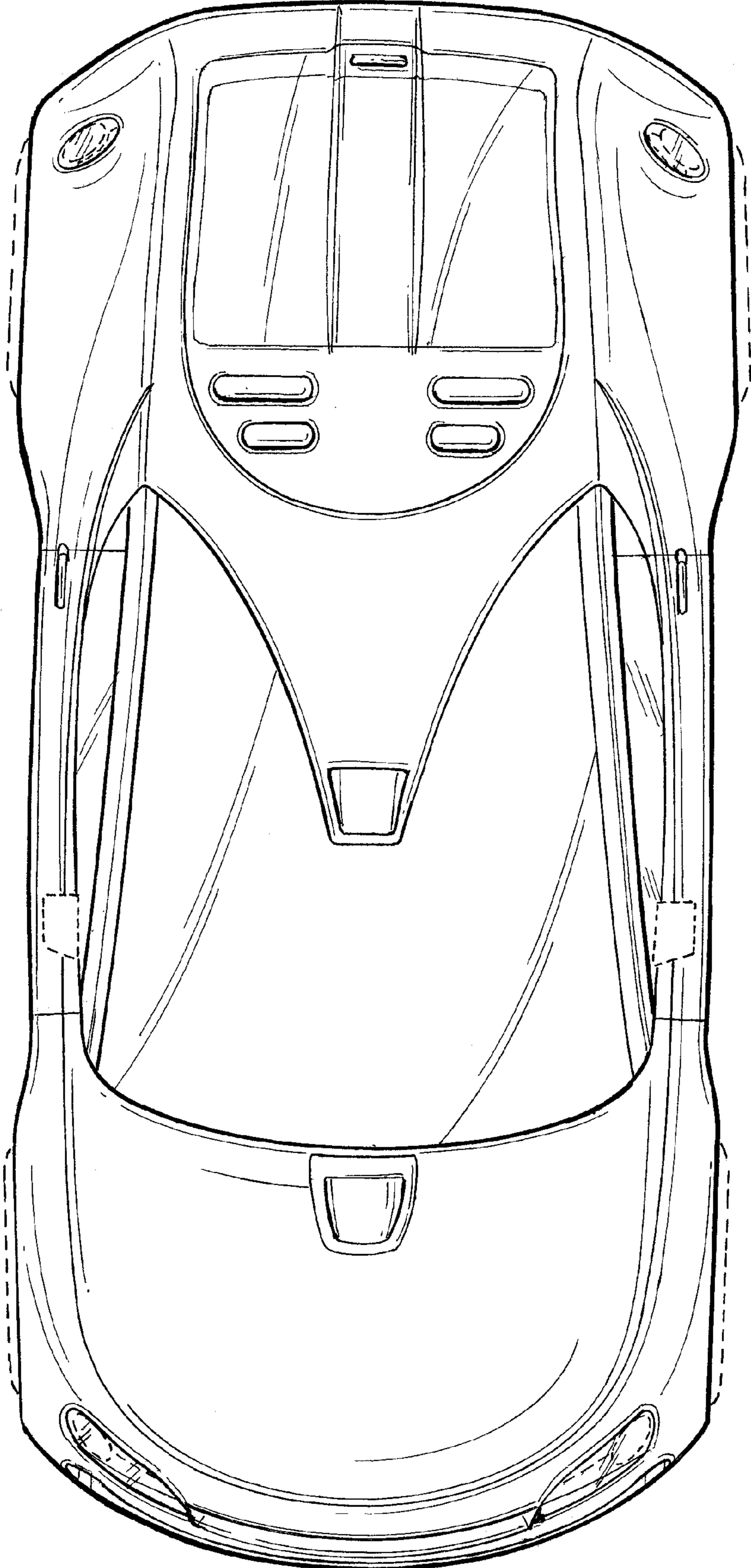

FIG. 6

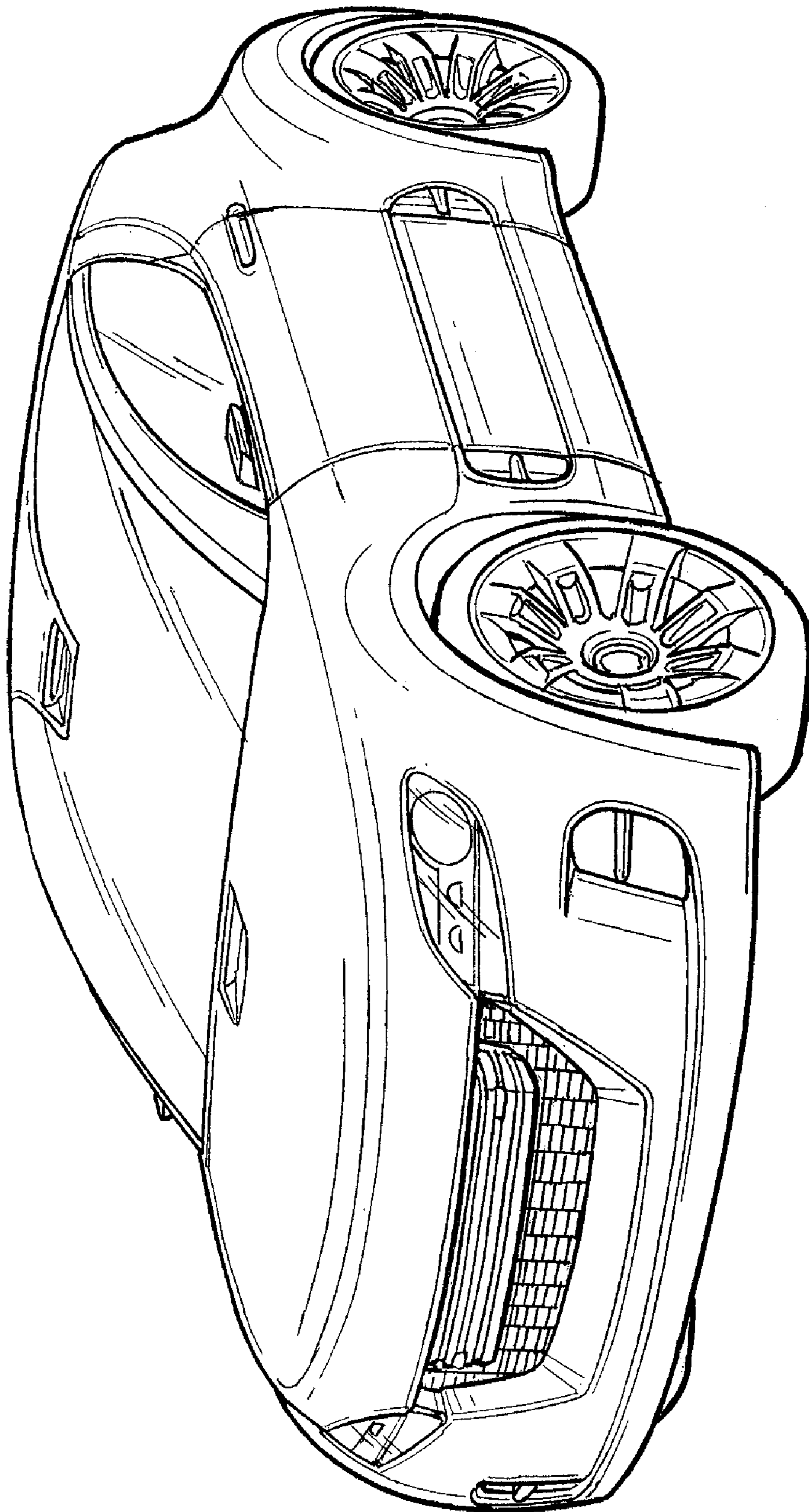

FIG. 7

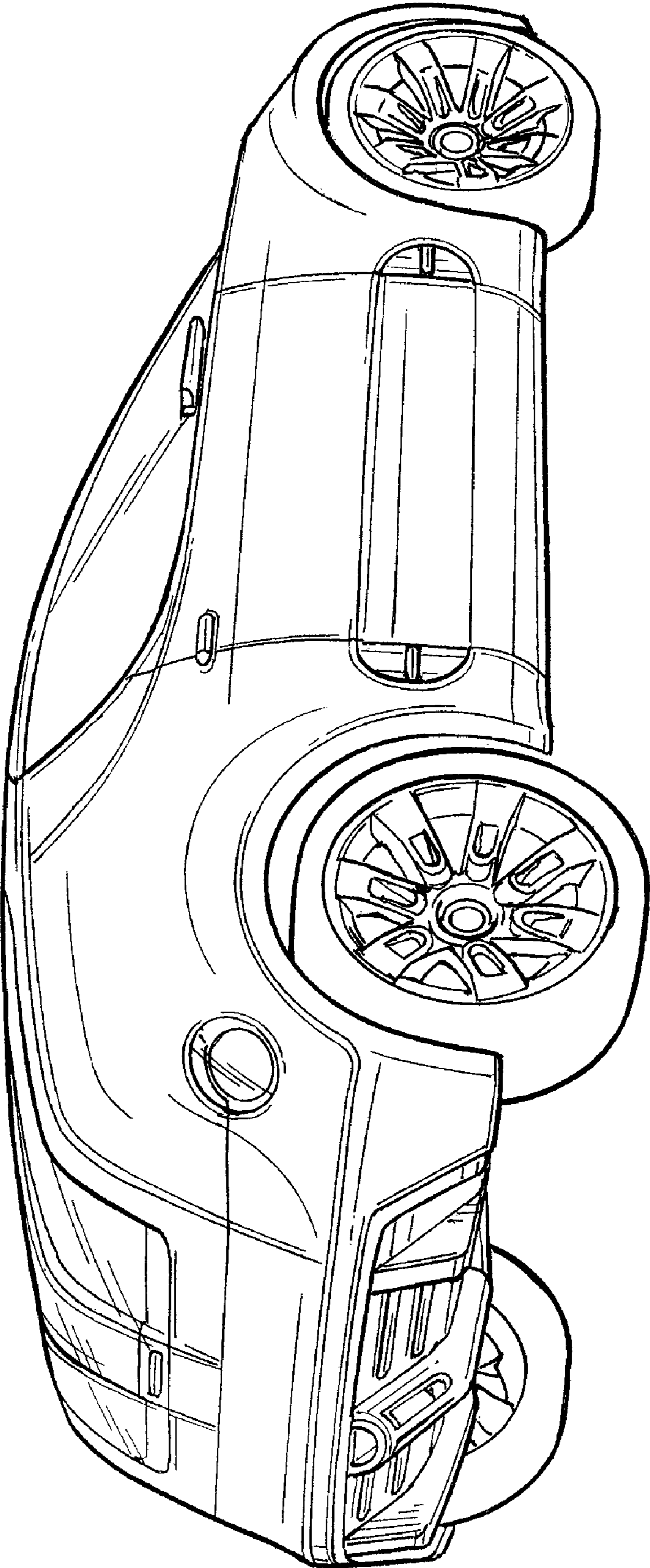

FIG. 8

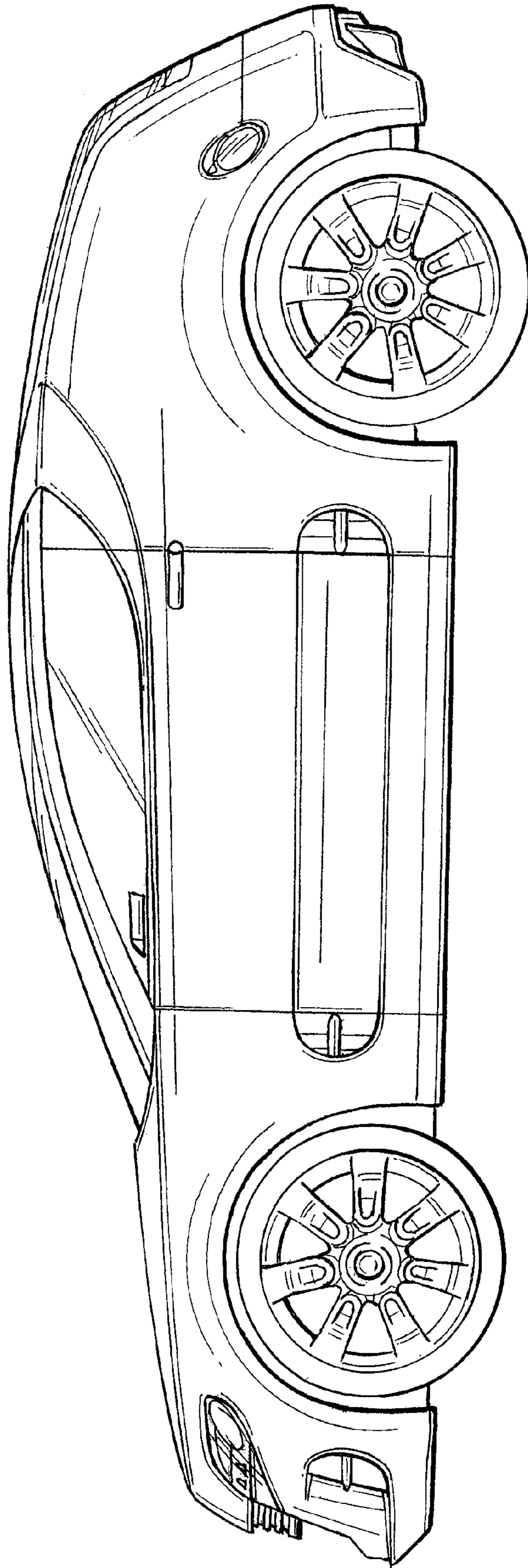

FIG. 9

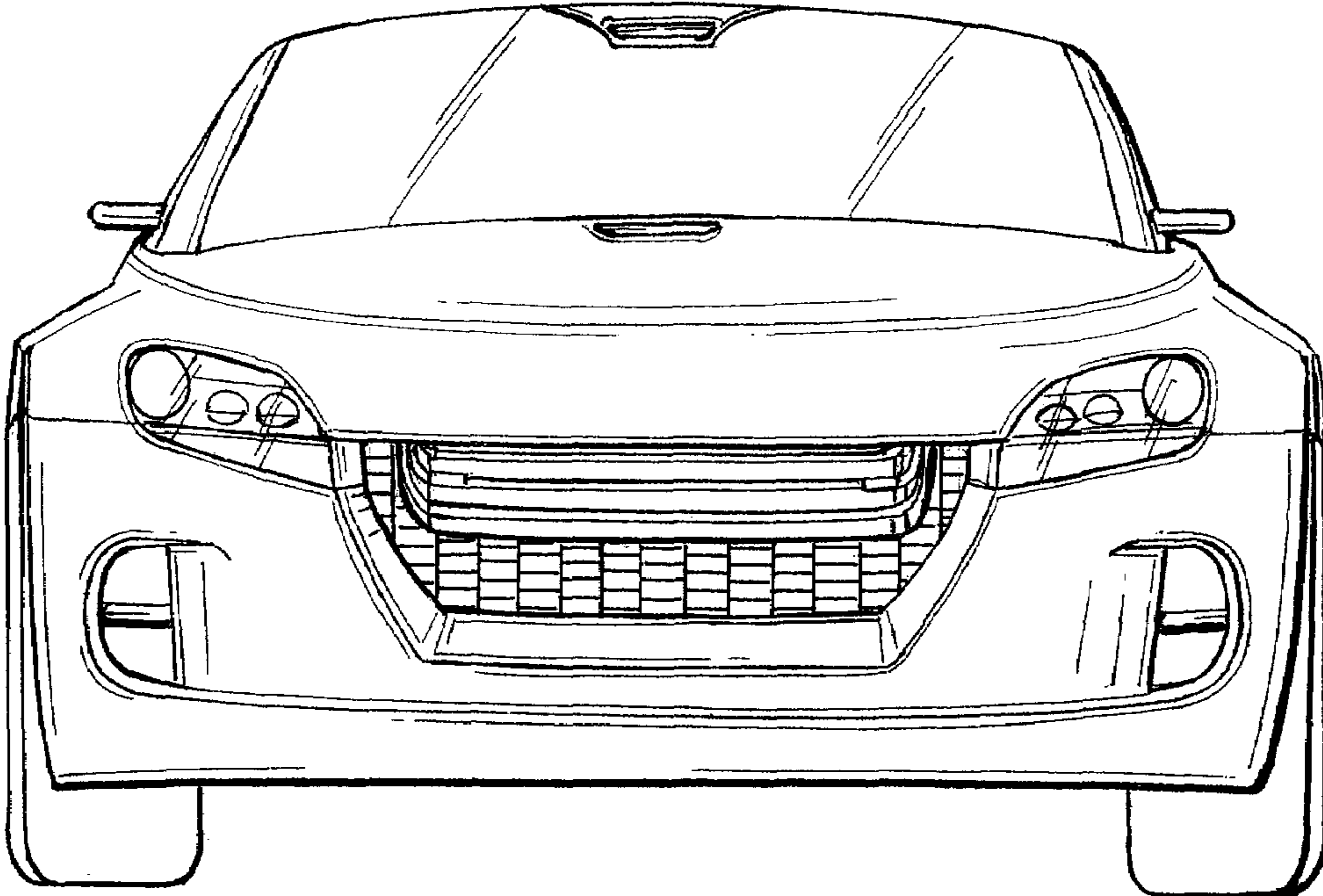

FIG. 10

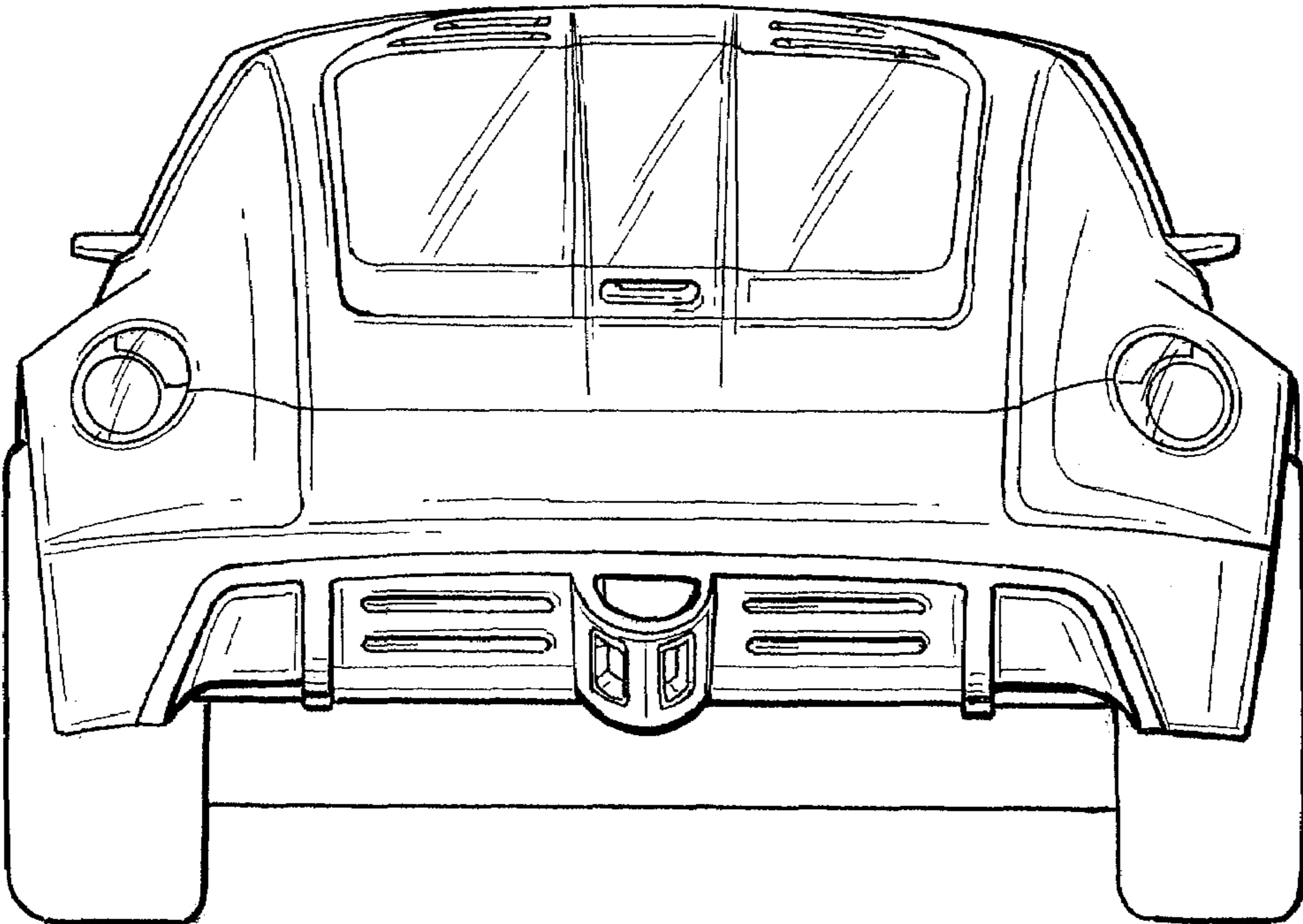

FIG. 11

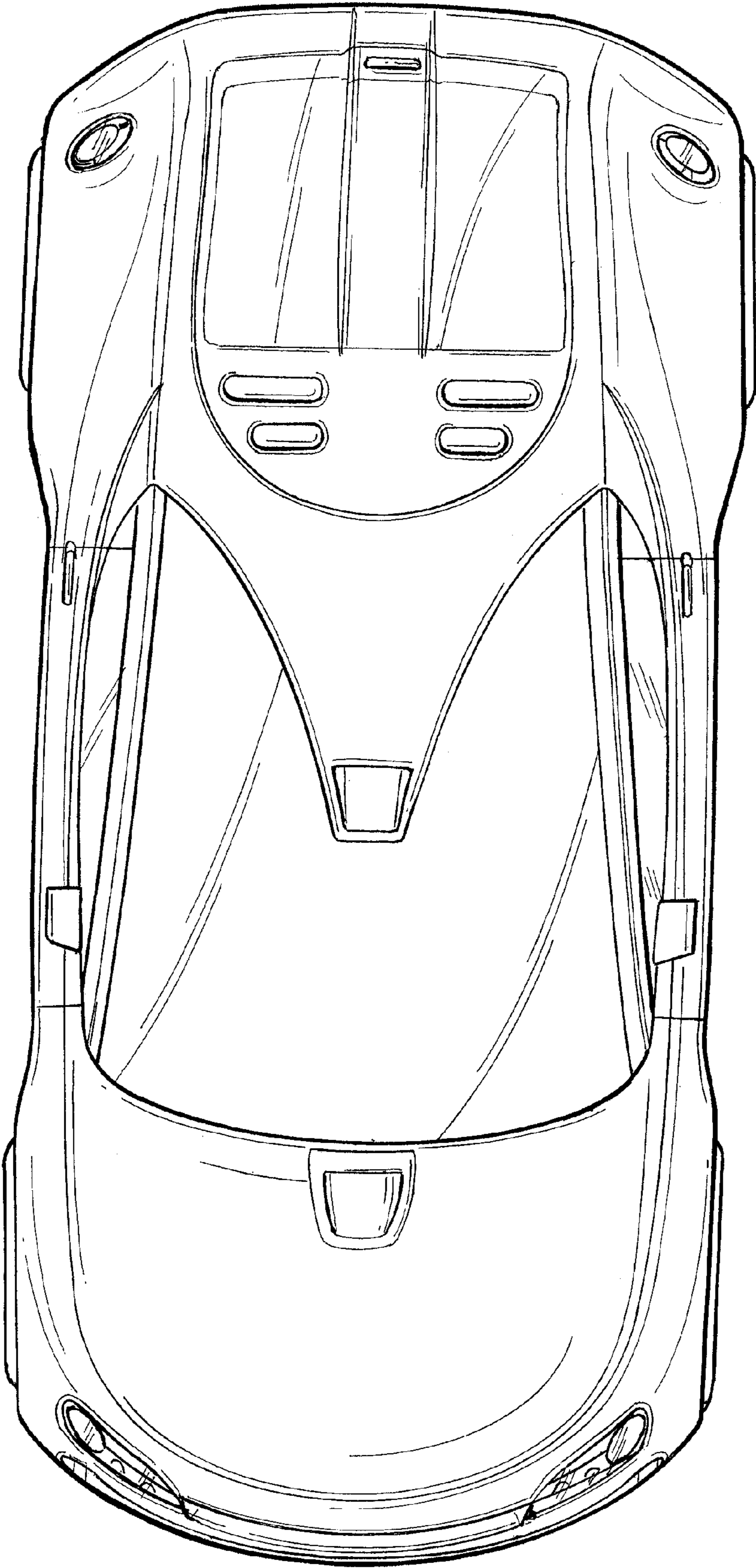

FIG. 12