



US00D555036S

(12) **United States Design Patent** (10) **Patent No.:** **US D555,036 S**
Eck (45) **Date of Patent:** **** Nov. 13, 2007**

(54) **ALL TERRAIN VEHICLE**

(75) Inventor: **Richard E. Eck**, Minneapolis, MN
(US)

(73) Assignee: **Polaris Industries Inc.**, Medina, MN
(US)

(**) Term: **14 Years**

(21) Appl. No.: **29/270,278**

(22) Filed: **Dec. 19, 2006**

Related U.S. Application Data

(63) Continuation of application No. 11/494,891, filed on
Jul. 28, 2006.

(51) **LOC (8) Cl.** **12-08**

(52) **U.S. Cl.** **D12/87**

(58) **Field of Classification Search** D12/87,
D12/86, 1; D21/433; 296/181.1
See application file for complete search history.

(56) **References Cited**

U.S. PATENT DOCUMENTS

D467,200 S * 12/2002 Luo et al. D12/87
D497,324 S * 10/2004 Chestnut et al. D12/87
2005/0173177 A1 8/2005 Smith et al.

OTHER PUBLICATIONS

Ray Sedorchuk, New for 2004, Yamaha Rhino 660 4x4, ATV
Connection Magazine, Copyright 1996-2005, 4 pgs., Internet
webpage.

YAMAHA, company website, 2006 Rhino 450 Auto 4x4, Copyright
2006, 4 pgs.

YAMAHA, company website, 2006 Rhino 660 Auto 4x4 Special
Edition, Copyright 2006, 4 pgs.

YAMAHA, company website, 2006 Rhino 660 Auto 4x4, Copyright
2006, 4 pgs.

YAMAHA, company website, 2006 Rhino 660 Auto 4x4 Exploring
Edition, Copyright 2006, 13 pgs.

Honda Hippo 1800 New Competition for Yamaha's Rhino, Dirt
Wheels Magazine, Apr. 2006, pp. 91-92.

Buyers' Guide Supplement, 2006 Kart Guide, Powersports Busi-
ness Magazine, 6 pgs.

* cited by examiner

Primary Examiner—Melody N. Brown

(74) *Attorney, Agent, or Firm*—Baker & Daniels LLP

(57) **CLAIM**

We claim the ornamental design for an all terrain vehicle, as
shown and described.

DESCRIPTION

FIG. 1 is a perspective view of an all terrain vehicle showing
my new design.

FIG. 2 is a left side view of the all terrain vehicle shown in
FIG. 1;

FIG. 3 is a right side view of the all terrain vehicle shown
in FIG. 1;

FIG. 4 is a top view of the all terrain vehicle shown in FIG.
1;

FIG. 5 is a bottom view of the all terrain vehicle shown in
FIG. 1;

FIG. 6 is a front view of the all terrain vehicle shown in FIG.
1; and,

FIG. 7 shows a rear view of the vehicle shown in FIG. 1.

The broken lines showing of environmental structure in
FIGS. 1 through 7 are for illustrative purposes only and form
no part of the claimed design.

1 Claim, 7 Drawing Sheets

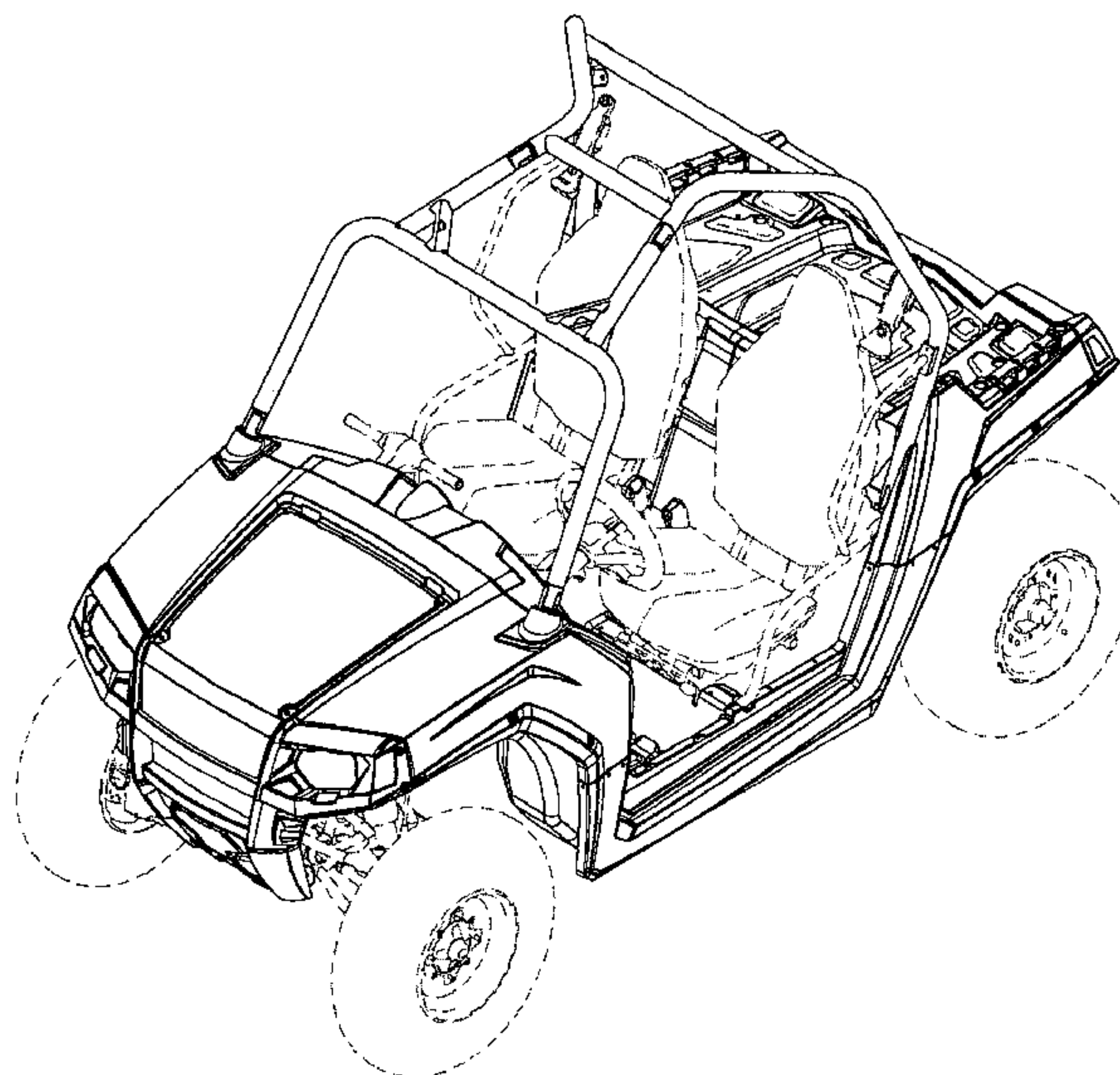

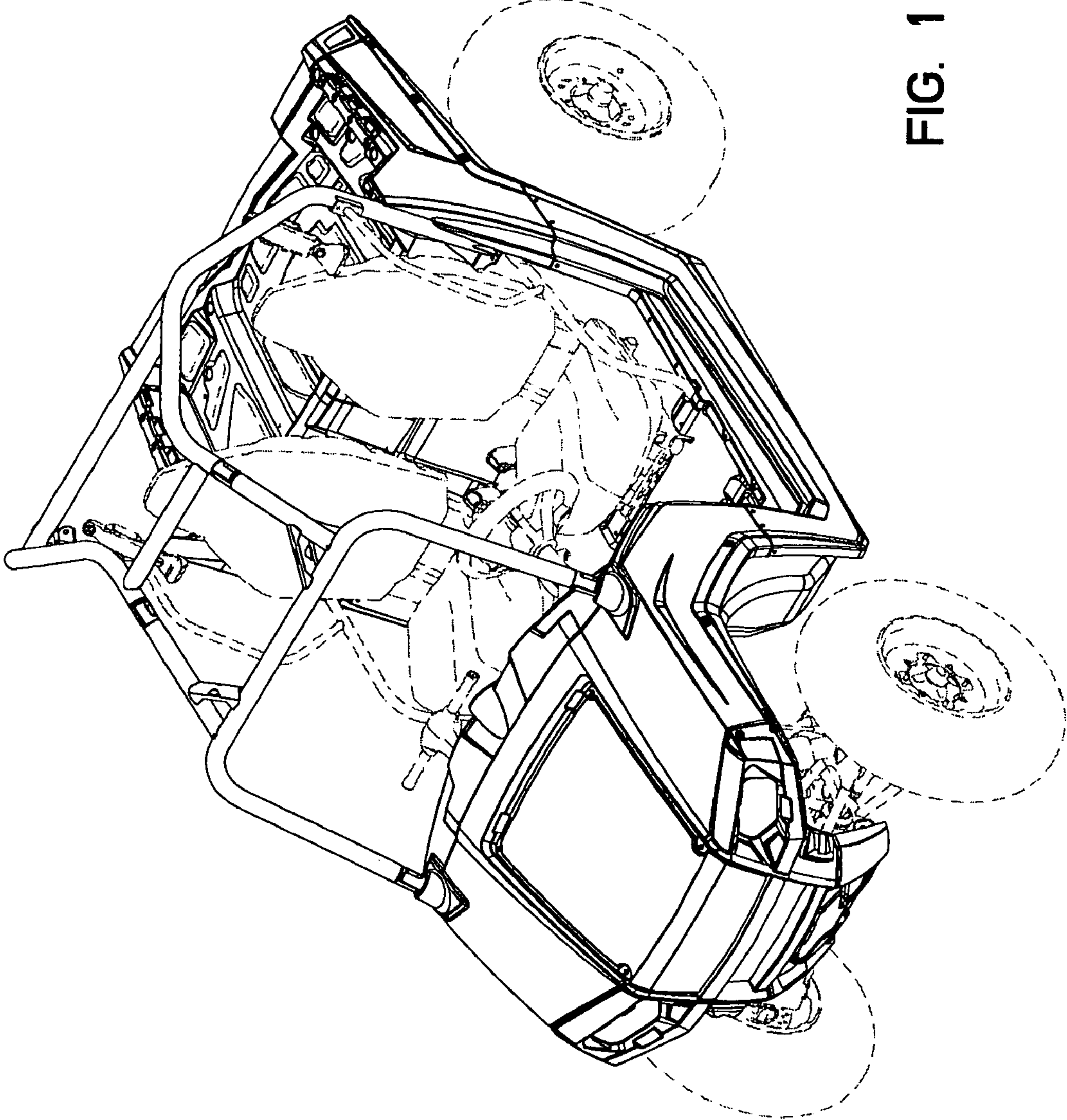

FIG. 1

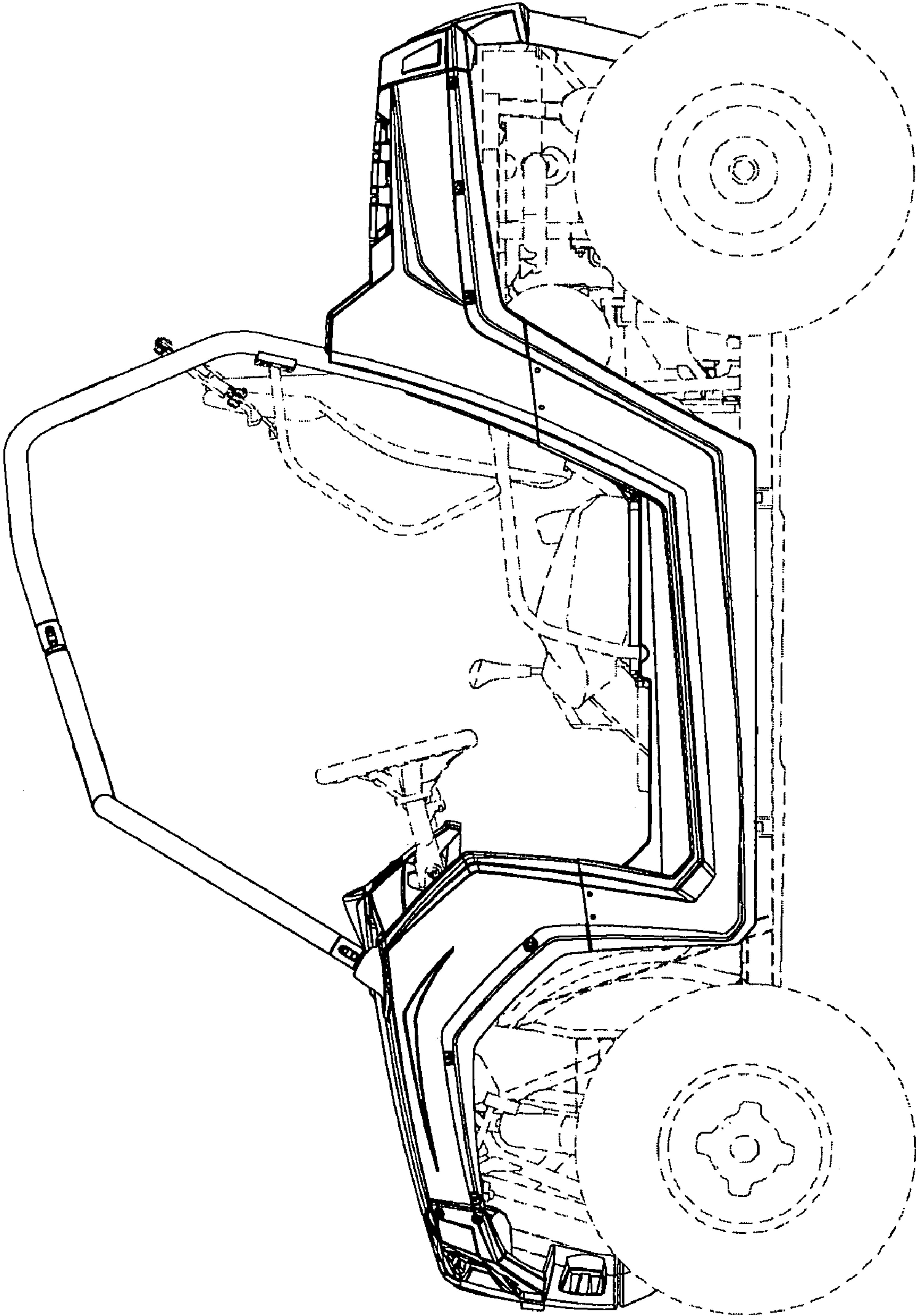

FIG. 2

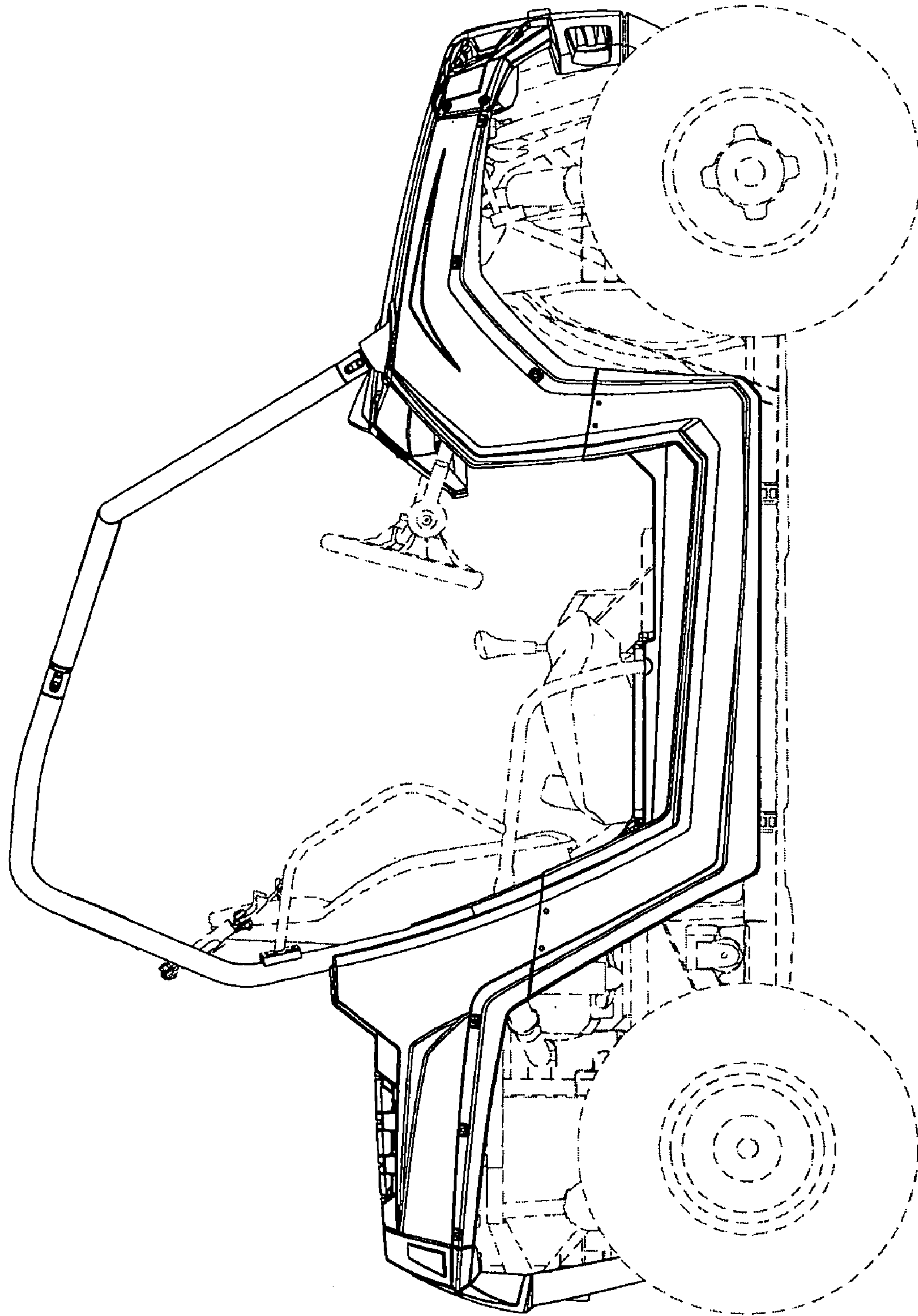

FIG. 3

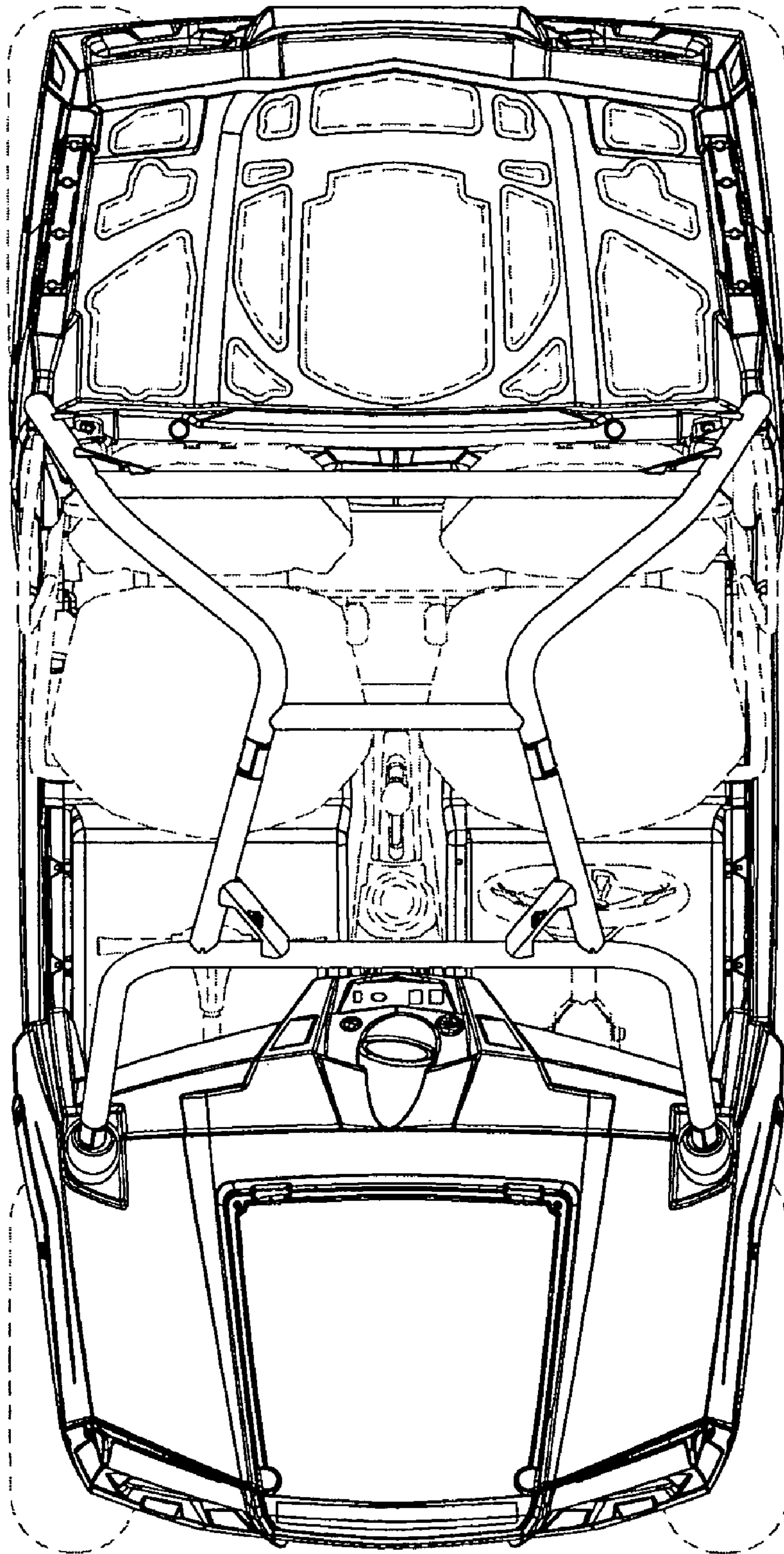

FIG. 4

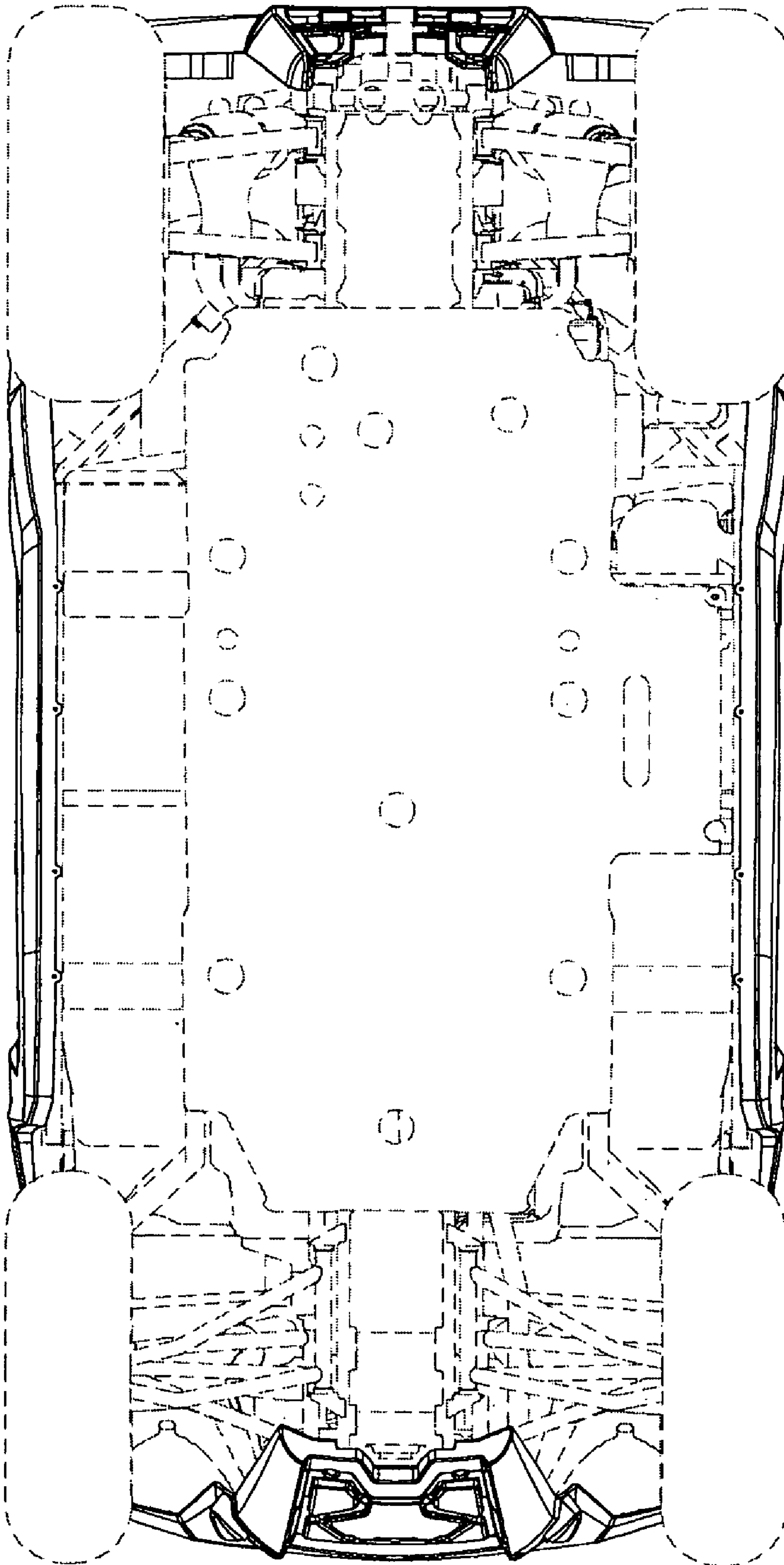

FIG. 5

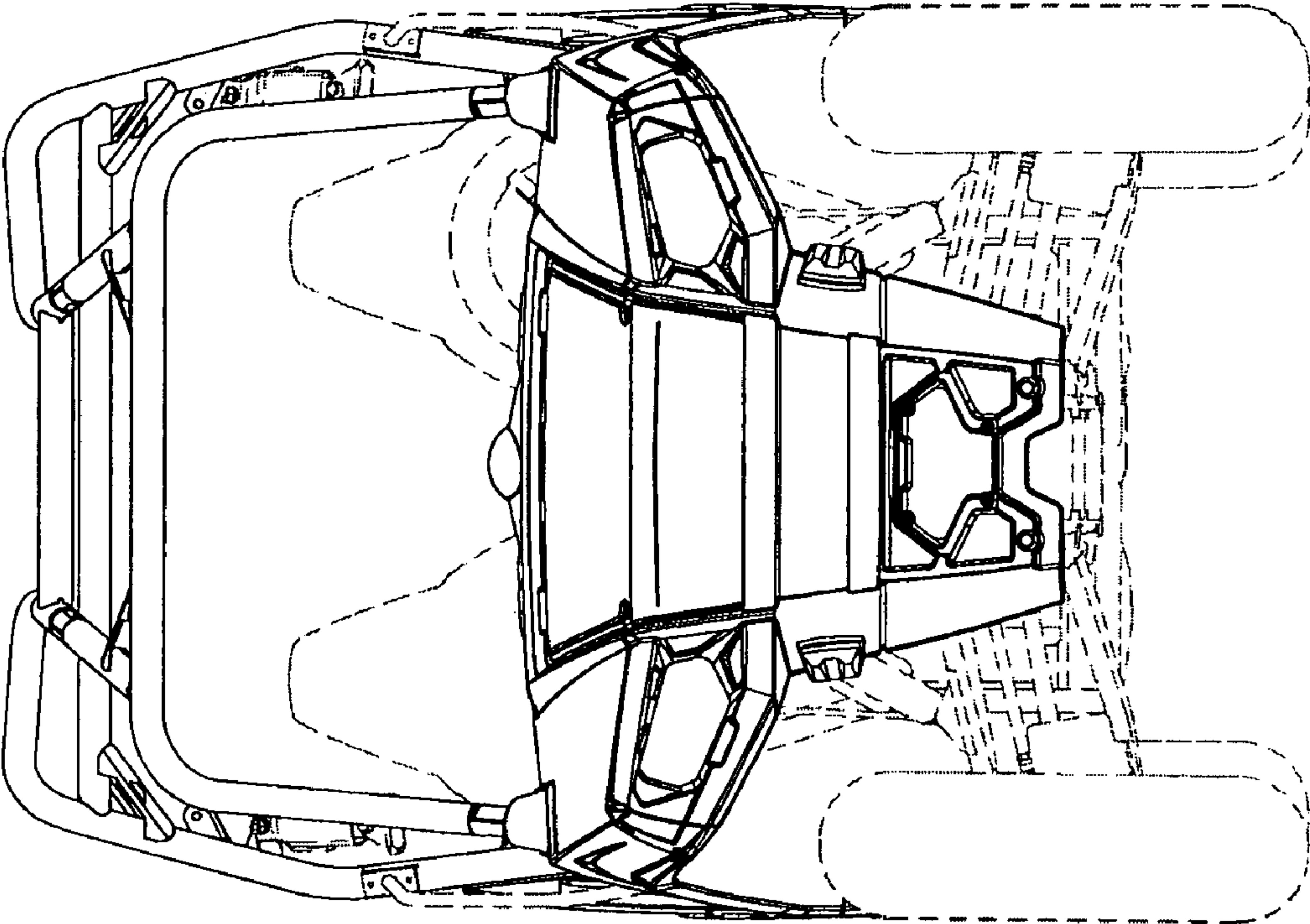

FIG. 6

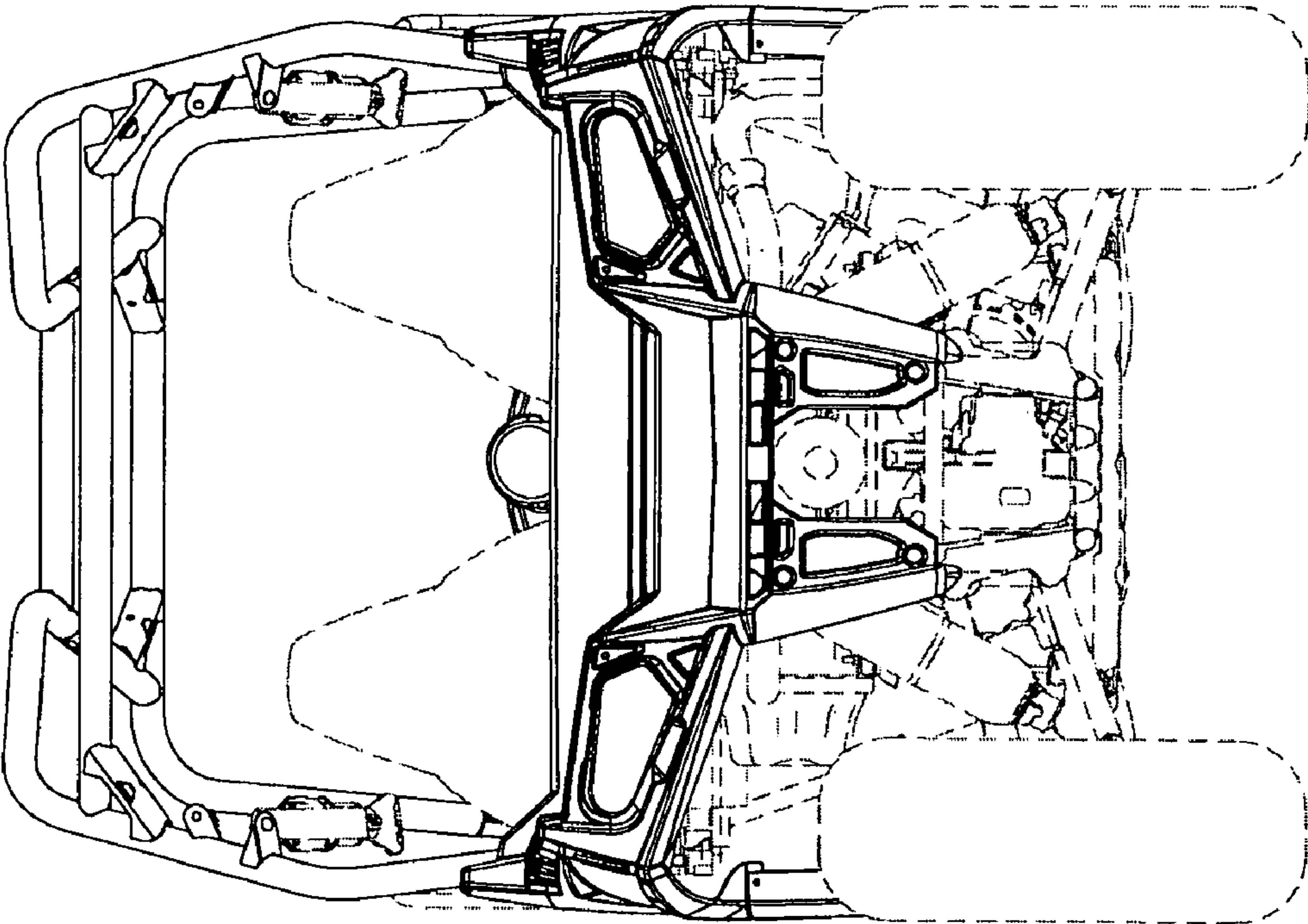

FIG. 7