



US00D554746S

(12) **United States Design Patent** (10) **Patent No.:** **US D554,746 S**  
**Davis et al.** (45) **Date of Patent:** **\*\* Nov. 6, 2007**

(54) **VOLATILE DISPENSER ELEMENT**

(75) Inventors: **Brian T. Davis**, Burlington, WI (US);  
**Saleh A. Saleh**, Vernon Hills, IL (US);  
**Joel E. Adair**, Racine, WI (US); **David**  
**P. Mather**, Milwaukee, WI (US); **Dan**  
**Mattano**, Varese (IT)

(73) Assignee: **S.C. Johnson & Son, Inc.**, Racine, WI  
(US)

(\*\*) Term: **14 Years**

(21) Appl. No.: **29/244,869**

(22) Filed: **Dec. 15, 2005**

(51) **LOC (8) Cl.** ..... **28-99**

(52) **U.S. Cl.** ..... **D23/366**

(58) **Field of Classification Search** ..... 261/DIG. 17,  
261/DIG. 42, DIG. 65, DIG. 88, DIG. 89;  
D23/355-369; D28/5, 6; 392/341, 342,  
392/386, 390, 392, 393, 394, 401; 239/34,  
239/35, 42, 60, 53-58, 136, 326; D11/43,  
D11/79

See application file for complete search history.

(56) **References Cited**

**U.S. PATENT DOCUMENTS**

D159,407	S	*	7/1950	Costello	.....	D23/366
2,513,919	A	*	7/1950	Costell	.....	392/392
D212,753	S	*	11/1968	Tughan	.....	D23/369
D246,986	S	*	1/1978	Costello	.....	D23/360
4,084,079	A	*	4/1978	Costello	.....	392/392
D254,930	S	*	5/1980	Mandon et al.	.....	D23/369
D254,931	S	*	5/1980	Mandon et al.	.....	D23/369
4,391,781	A	*	7/1983	van Lit	.....	422/125
D296,820	S	*	7/1988	Suhajda	.....	D23/363
D349,157	S	*	7/1994	Rymer	.....	D23/362
D373,626	S	*	9/1996	Dente et al.	.....	D23/366
5,752,658	A	*	5/1998	Gibbs et al.	.....	239/56
D400,662	S	*	11/1998	Davis	.....	D23/366
D403,420	S	*	12/1998	Vullion	.....	D23/367
6,103,201	A	*	8/2000	Green	.....	422/124
6,148,143	A	*	11/2000	Steinel, Jr.	.....	392/390

D441,441	S	*	5/2001	Upson	.....	D23/366
D443,924	S	*	6/2001	Renella	.....	D23/366
D455,484	S	*	4/2002	Hensel	.....	D23/366
D455,485	S	*	4/2002	Hensel	.....	D23/366
D489,123	S	*	4/2004	Basaganas Millan	.....	D23/366
D491,257	S	*	6/2004	Picken, Jr.	.....	D23/366
6,775,470	B2	*	8/2004	Zobebe et al.	.....	392/390
D502,540	S		3/2005	Cruver et al.		
D503,973	S	*	4/2005	Millan	.....	D23/366

\* cited by examiner

*Primary Examiner*—Sandra Snapp

(57) **CLAIM**

The ornamental design for a volatile dispenser element, as shown and described.

**DESCRIPTION**

In preferred embodiments the nature of this product is as a housing for an electric heat activated dispenser of volatile actives, or a refill cartridge for use therewith, or the combination of such a housing and such a refill

FIG. 1 is a right, bottom, frontal perspective view of a volatile dispenser element in the form of a housing for a volatile dispenser embodying our new design;

FIG. 2 is a right side elevational view thereof;

FIG. 3 is a left side elevational view thereof;

FIG. 4 is a front elevational view thereof;

FIG. 5 is a rear elevational view thereof;

FIG. 6 is a top plan view thereof;

FIG. 7 is a bottom plan view thereof;

FIG. 8 is a right, bottom, frontal perspective view of a second embodiment of our new design which is a volatile dispenser element in the form of a refill cartridge;

FIG. 9 is a right side elevational view thereof;

FIG. 10 is a left side elevational view thereof;

FIG. 11 is a front elevational view thereof;

FIG. 12 is a rear elevational view thereof;

FIG. 13 is a top plan view thereof;

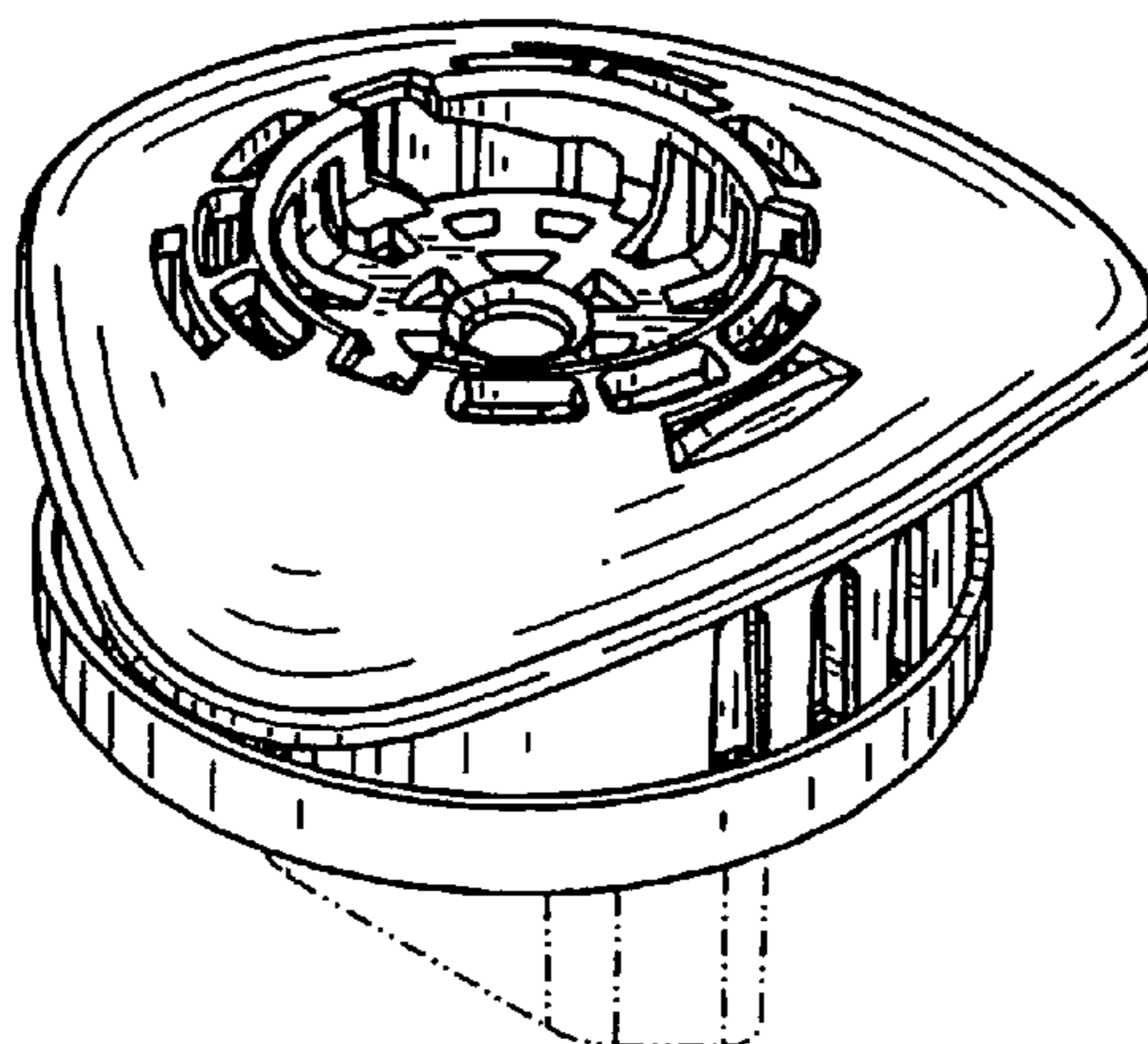

FIG. 14 is a bottom plan view thereof;

FIG. 15 is a right, bottom, frontal perspective view of a third embodiment of our new design which is a volatile dispenser housing with a refill cartridge installed thereon;

FIG. 16 is a right side elevational view thereof;

FIG. 17 is a left side elevational view thereof;

FIG. 18 is a front elevational view thereof;

FIG. 19 is a rear elevational view thereof;

FIG. 20 is a top plan view thereof;

FIG. 21 is a bottom plan view thereof;

FIG. 22 is a right, bottom, frontal perspective view of a volatile dispenser element in the form of a second housing for a volatile dispenser embodying our new design;

FIG. 23 is a right side elevational view thereof;

FIG. 24 is a left side elevational view thereof;

FIG. 25 is a front elevational view thereof;

FIG. 26 is a rear elevational view thereof;

FIG. 27 is a top plan view thereof;

FIG. 28 is a bottom plan view thereof;

FIG. 29 is a right, bottom, frontal perspective view of a fifth embodiment of our new design which is the second volatile dispenser housing with the refill cartridge of FIG. 8 installed thereon;

FIG. 30 is a right side elevational view thereof;

FIG. 31 is a left side elevational view thereof;

FIG. 32 is a front elevational view thereof;

FIG. 33 is a rear elevational view thereof;

FIG. 34 is a top plan view thereof; and,

FIG. 35 is a bottom plan view thereof.

The broken line representations of plug environment in FIGS. 2, 3, 5-7, 16, 17, and 19-21 are for purposes of illustration only, and form no part of the claimed design.

**1 Claim, 9 Drawing Sheets**

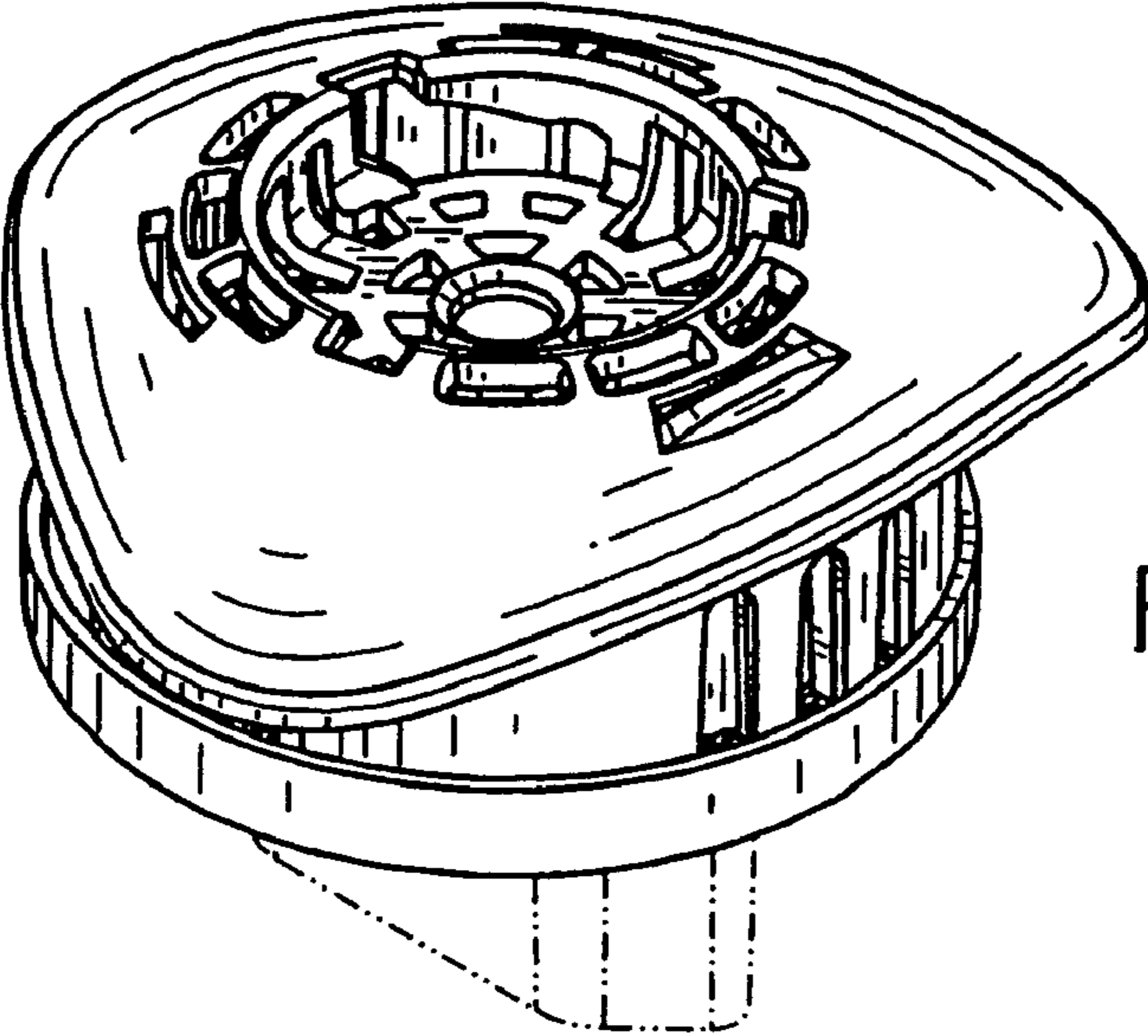

FIG. 1

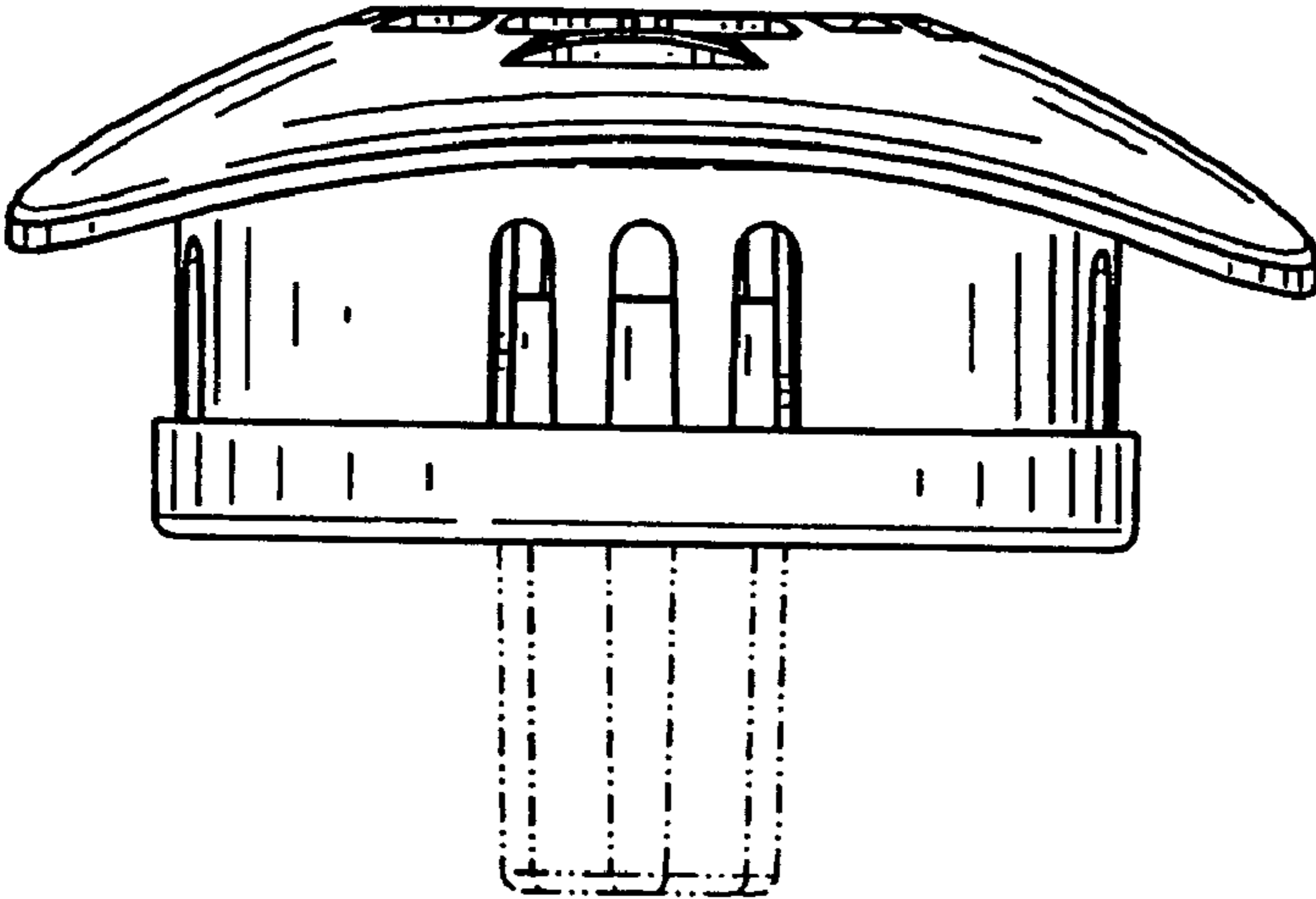

FIG. 2

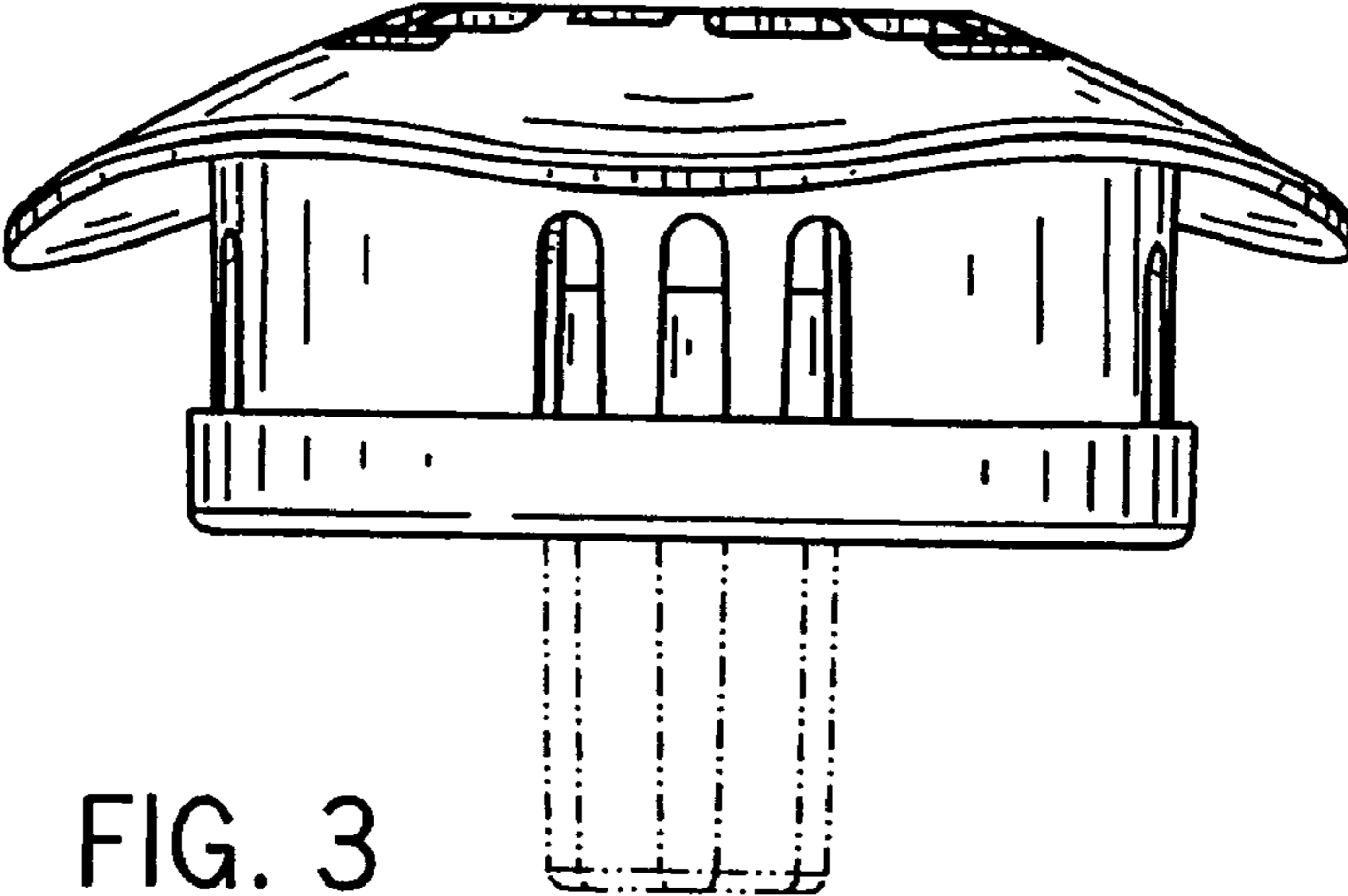

FIG. 3

FIG. 4

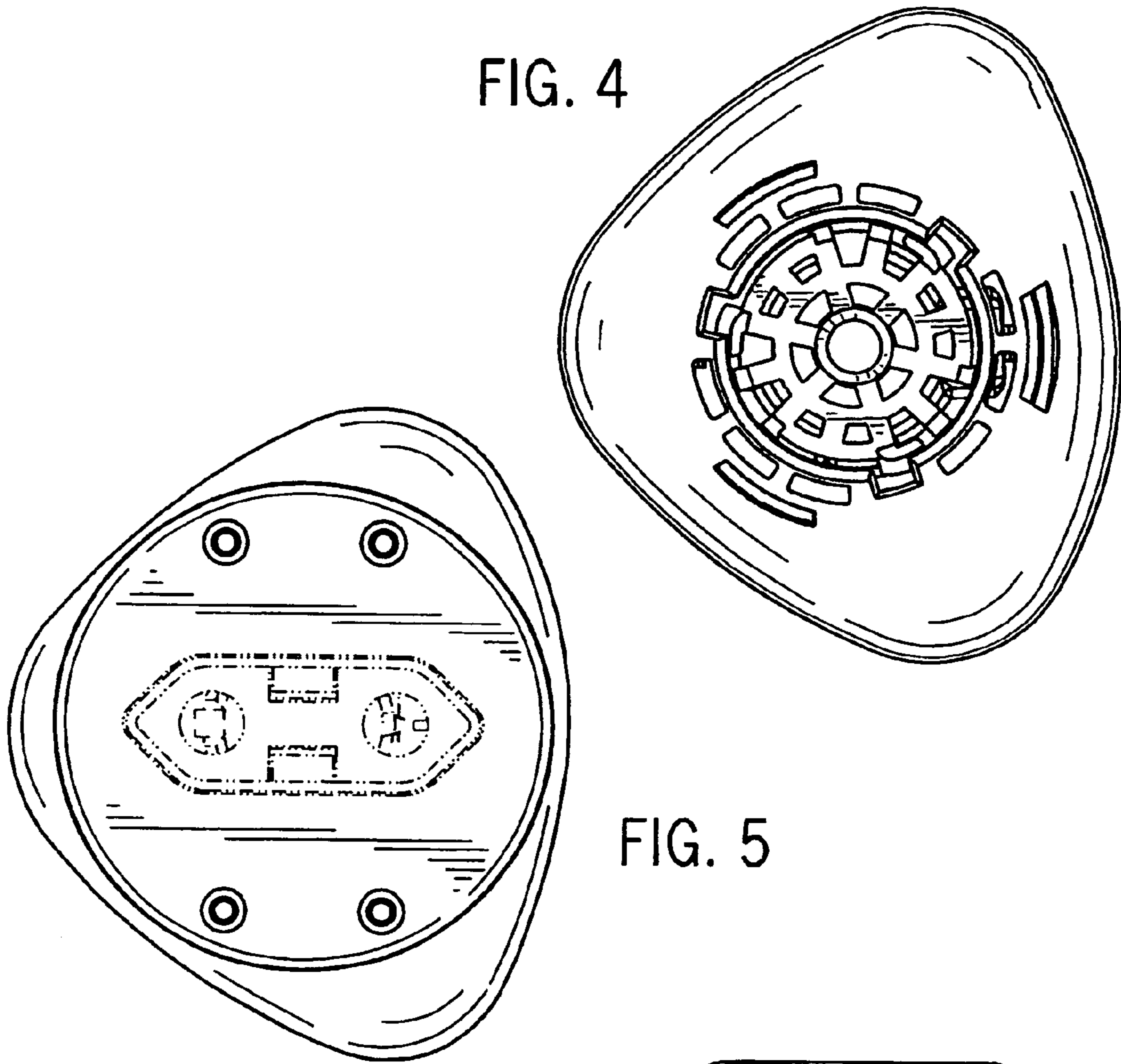

FIG. 5

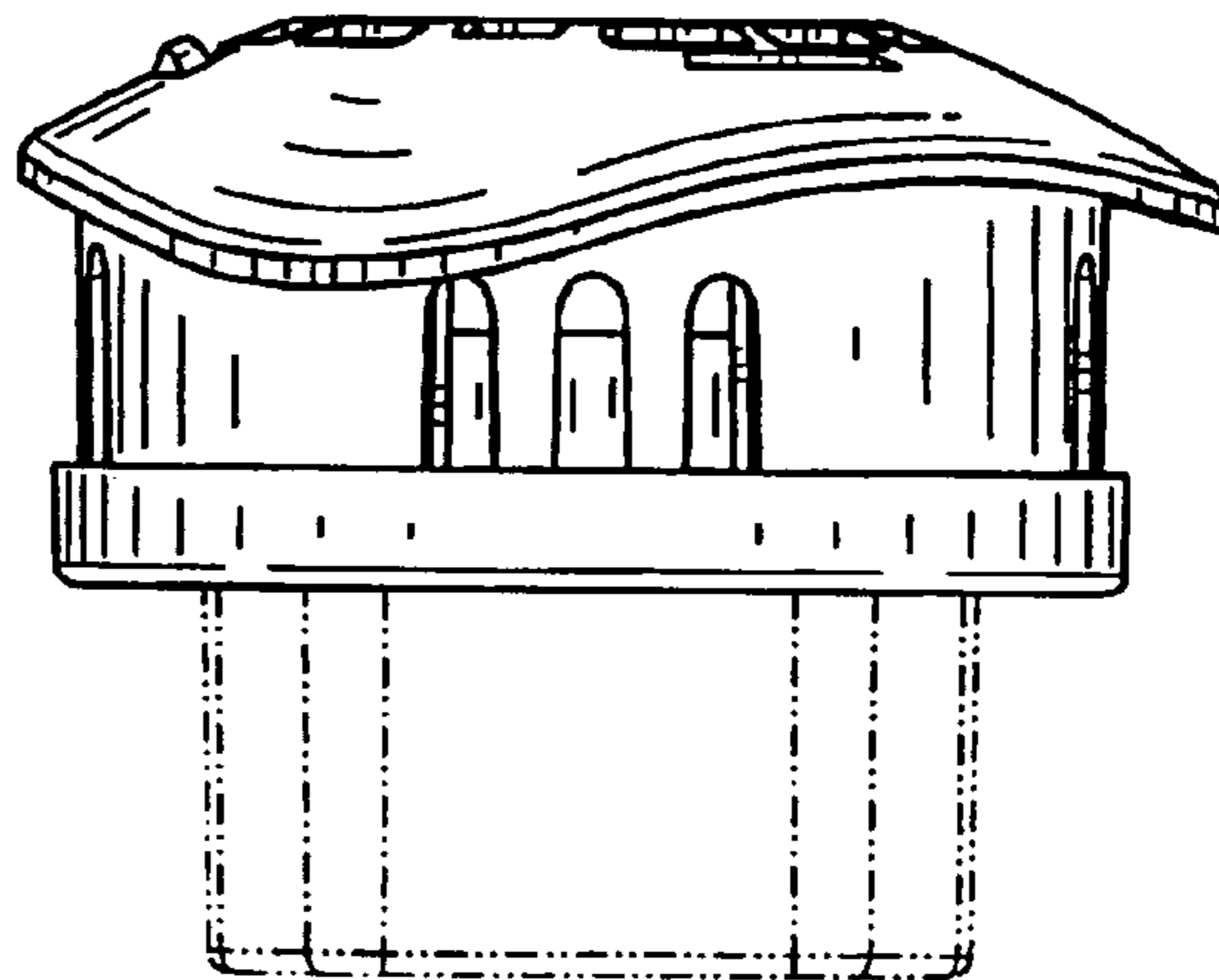

FIG. 6

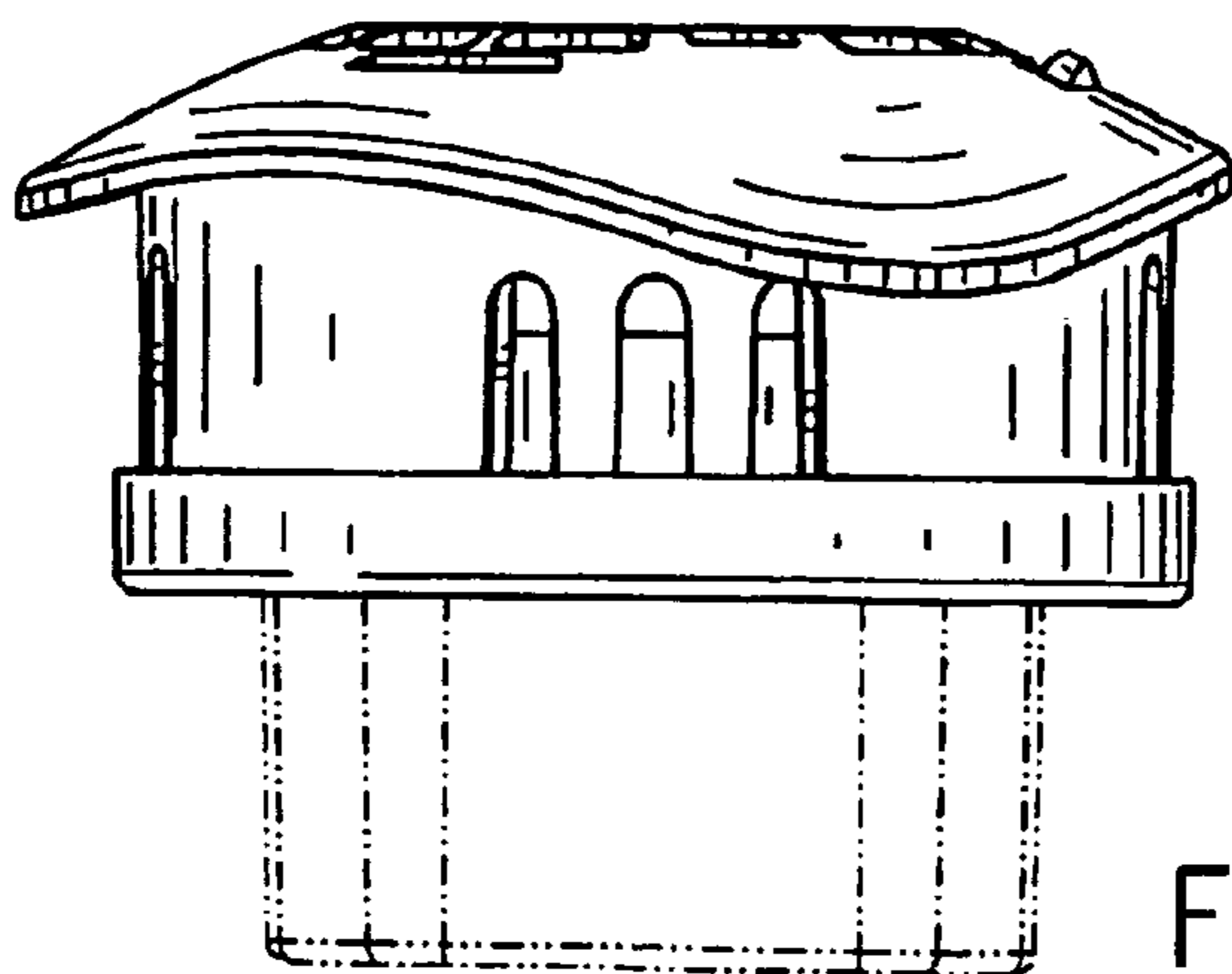

FIG. 7

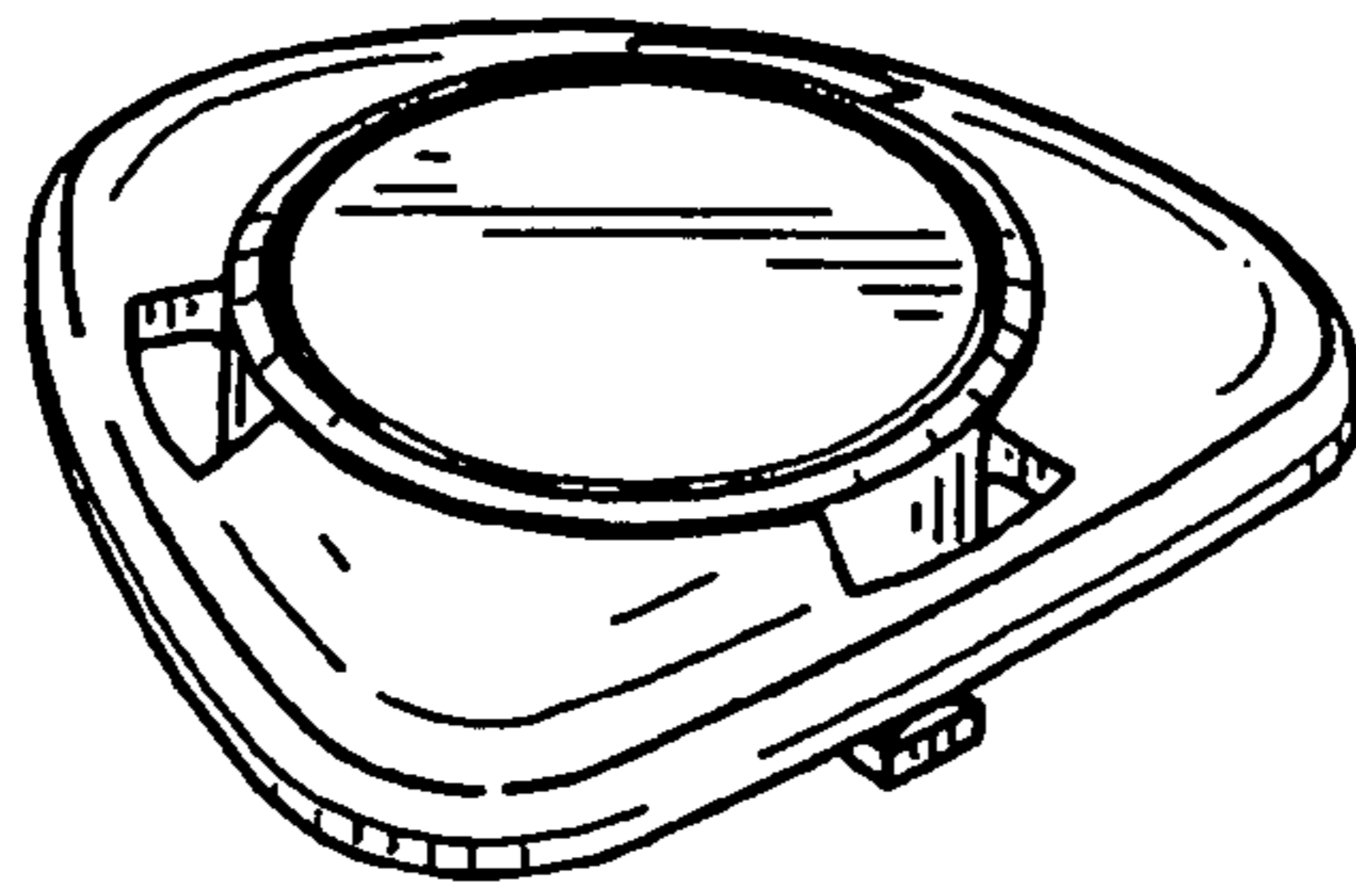

FIG. 8

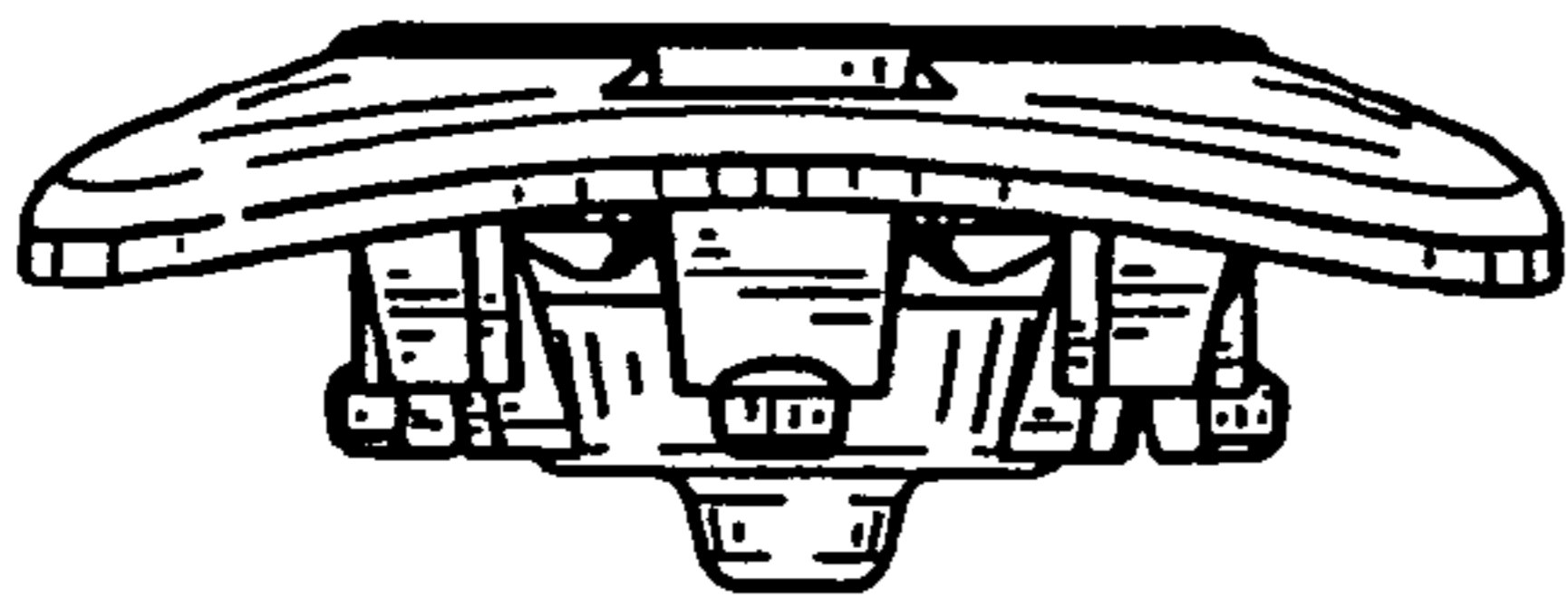

FIG. 9

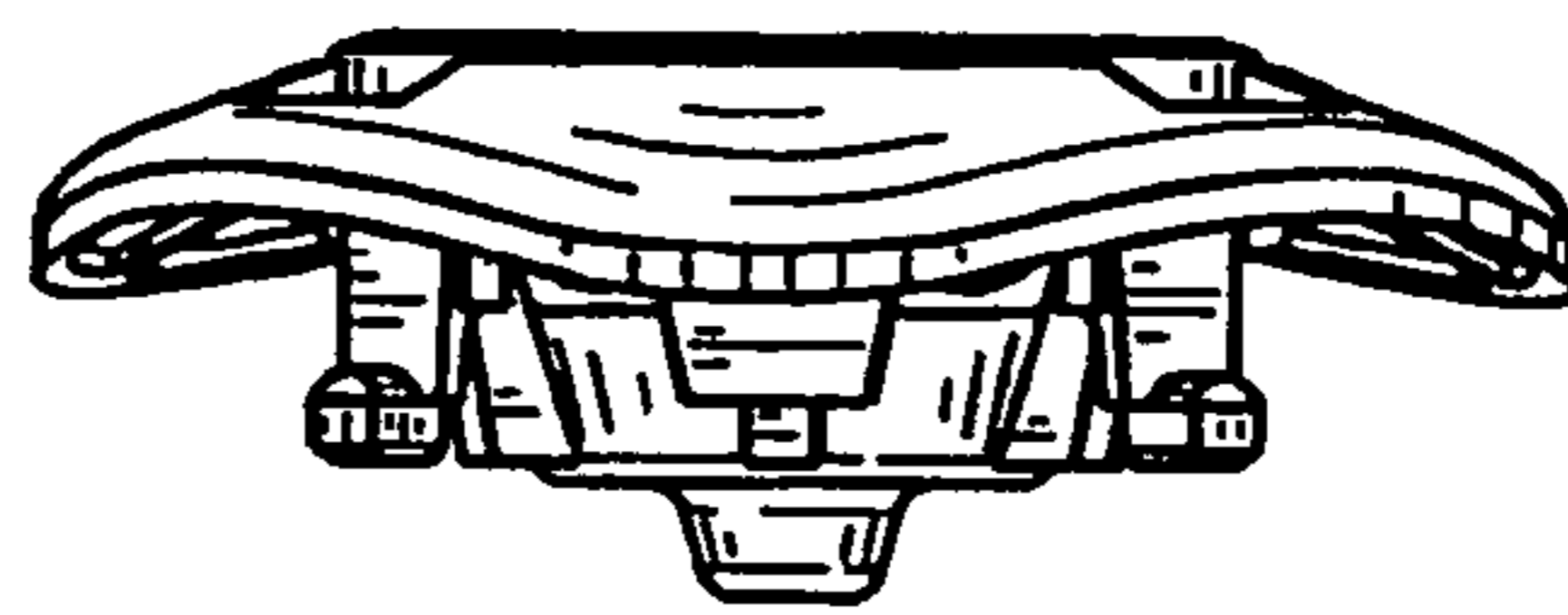

FIG. 10

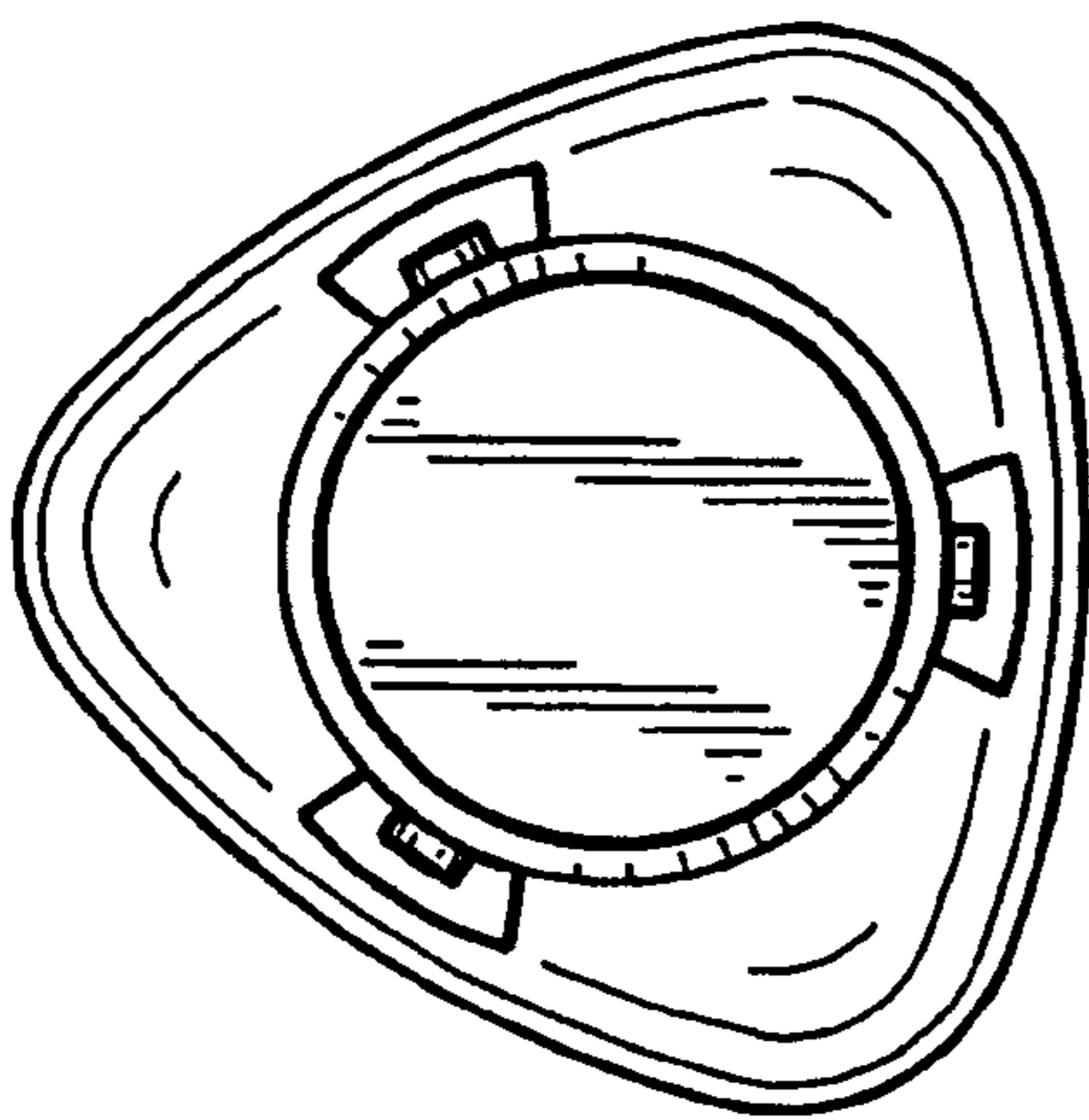

FIG. 11

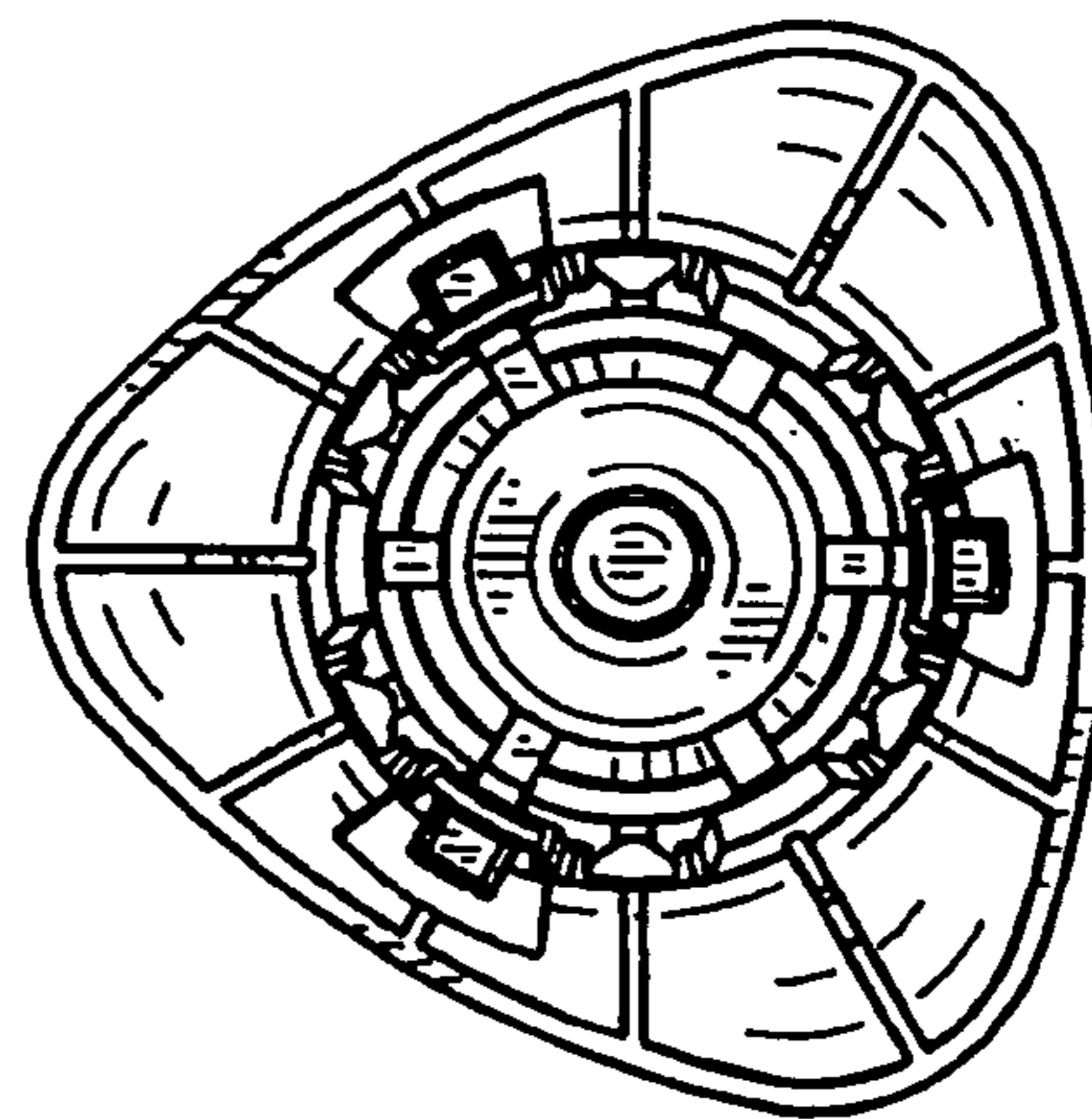

FIG. 12

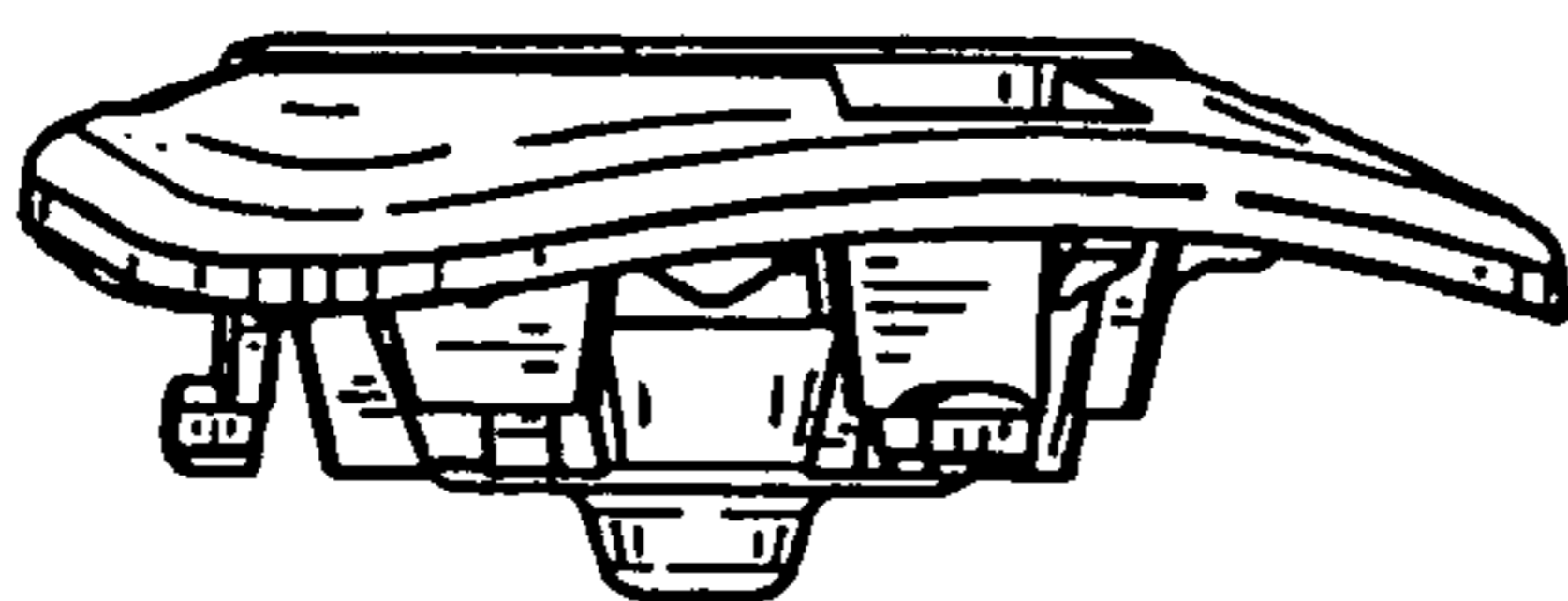

FIG. 13

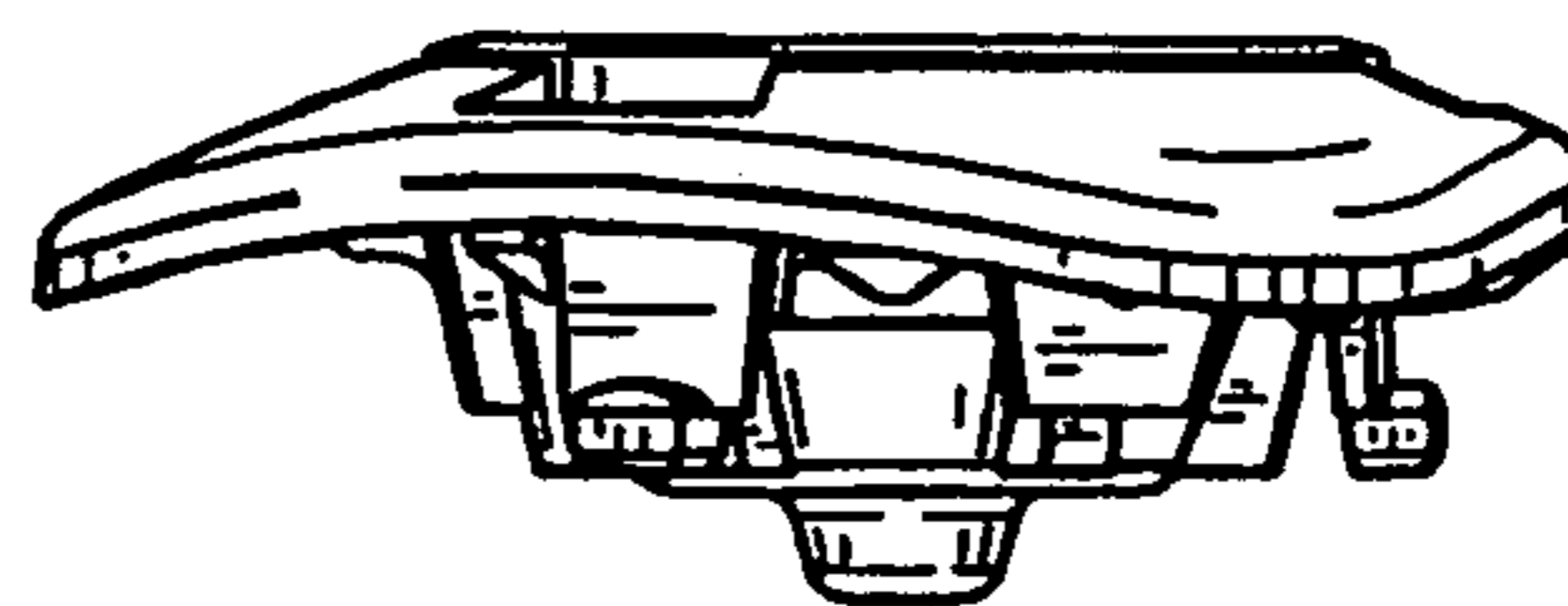

FIG. 14

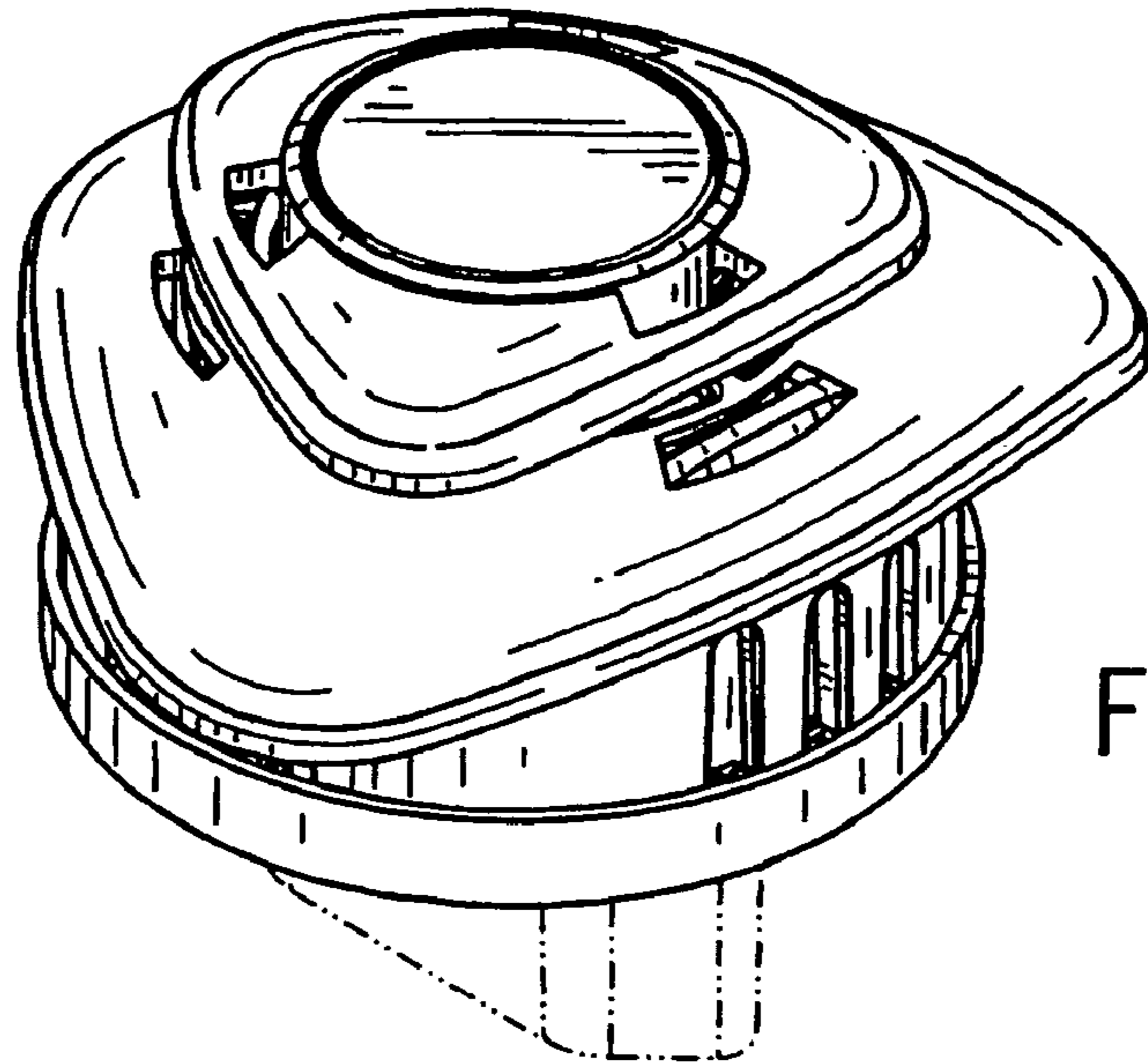

FIG. 15

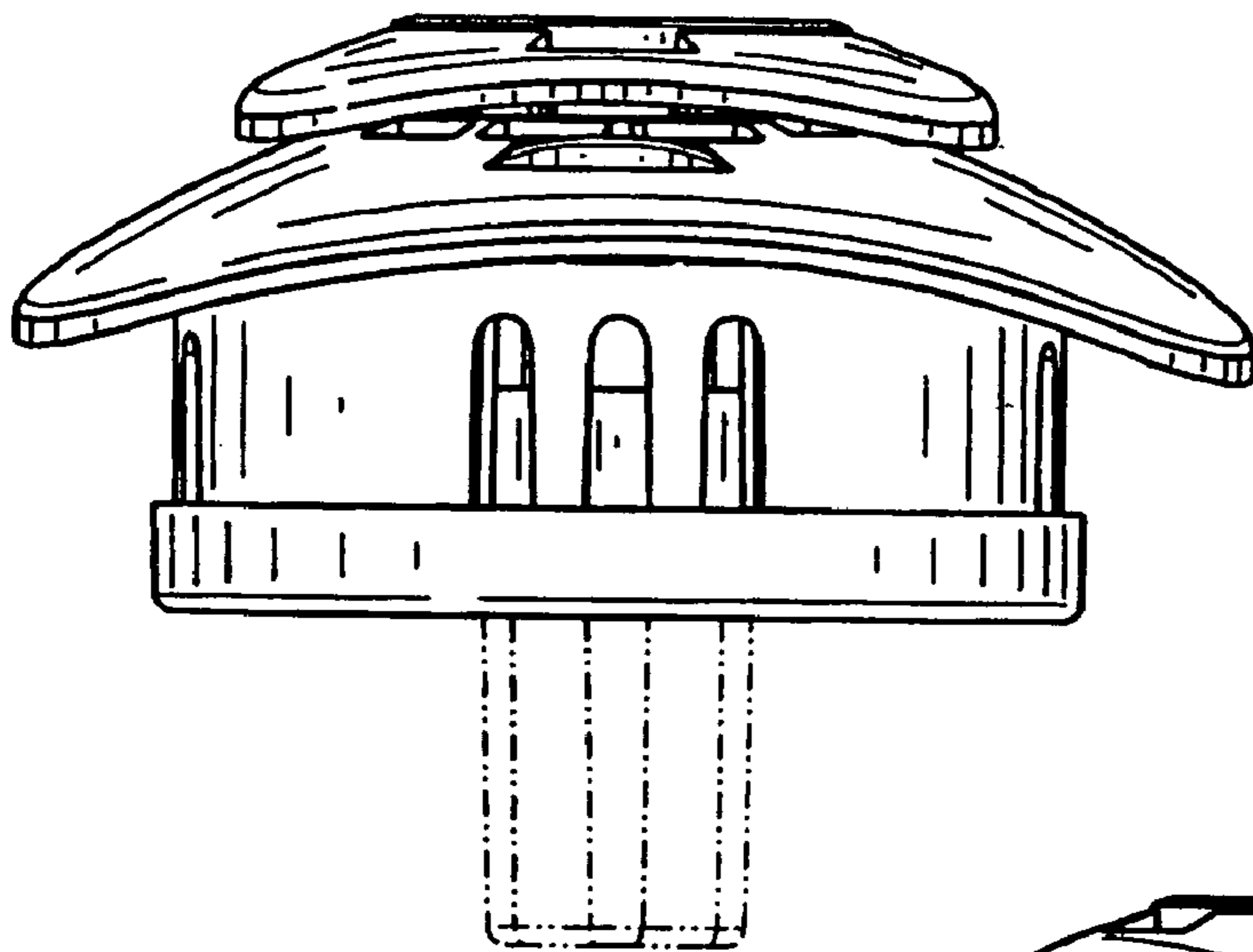

FIG. 16

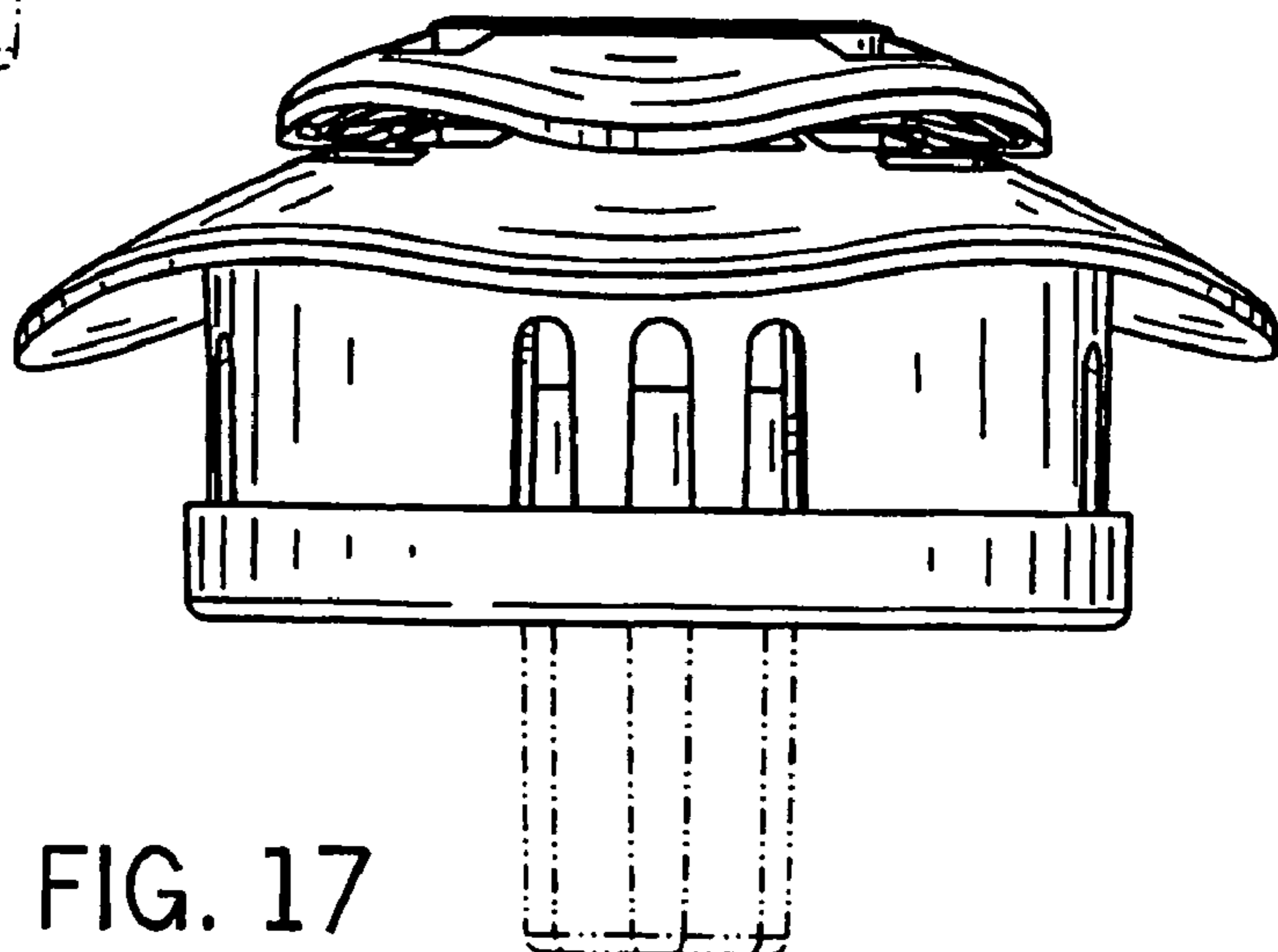

FIG. 17

FIG. 18

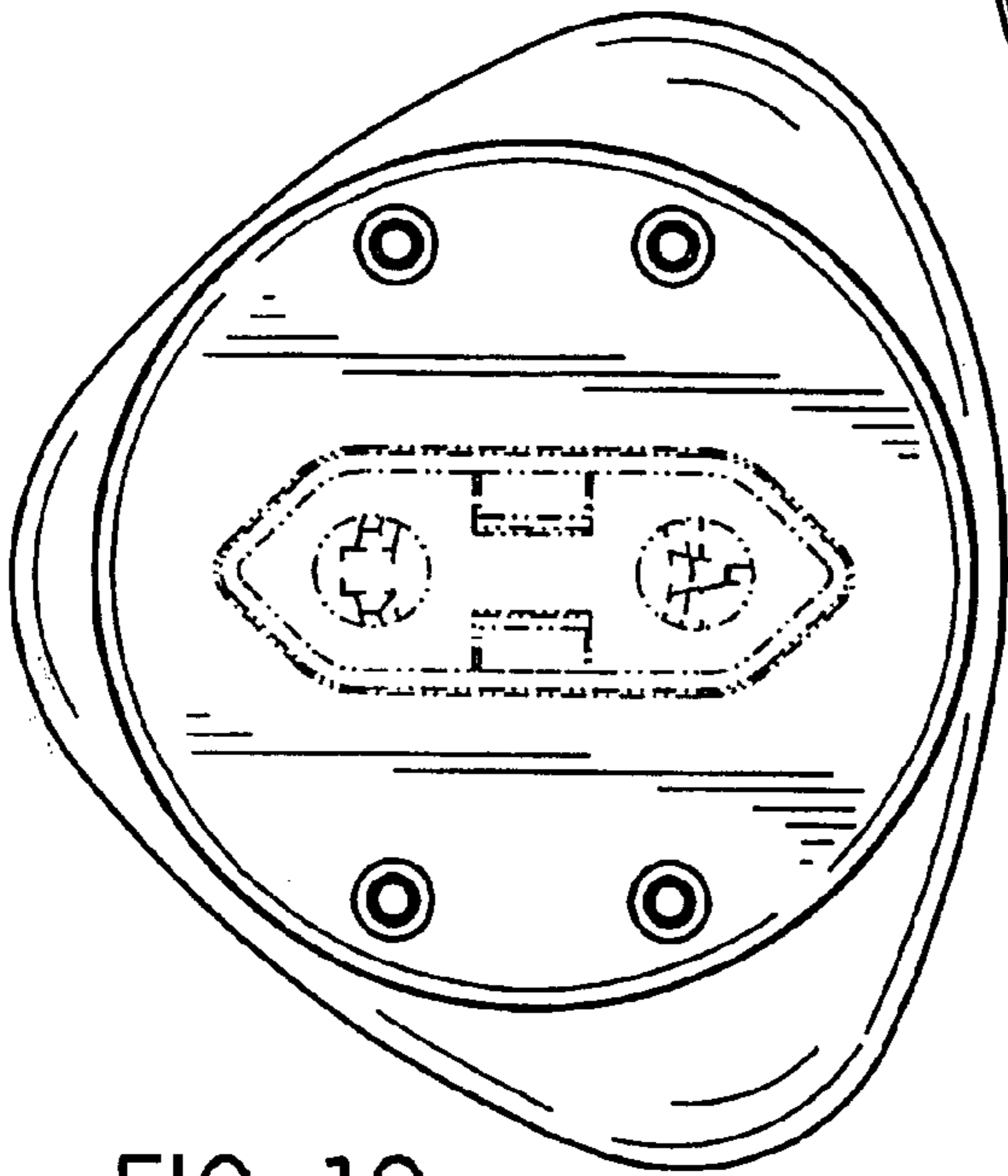
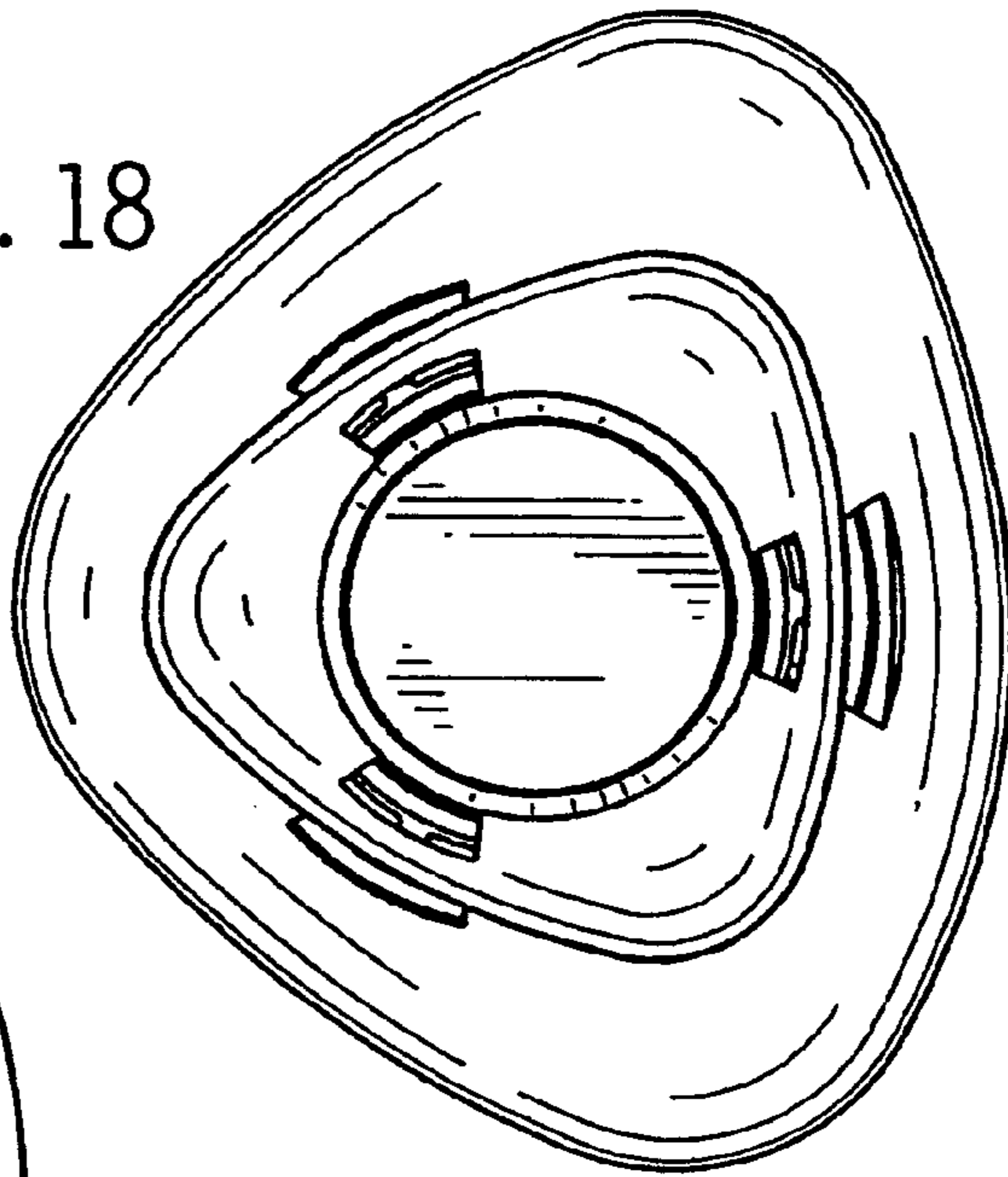

FIG. 19

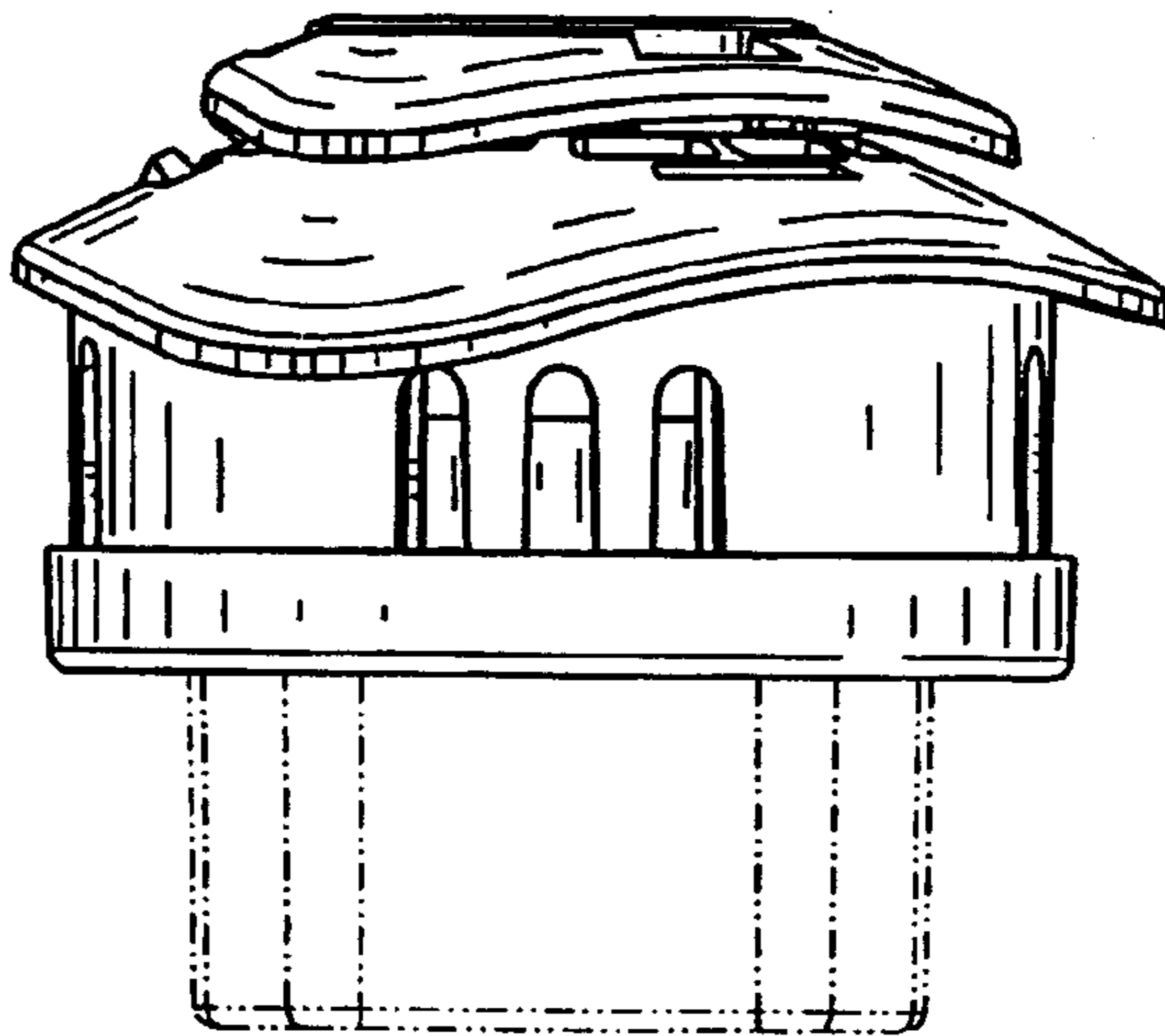

FIG. 20

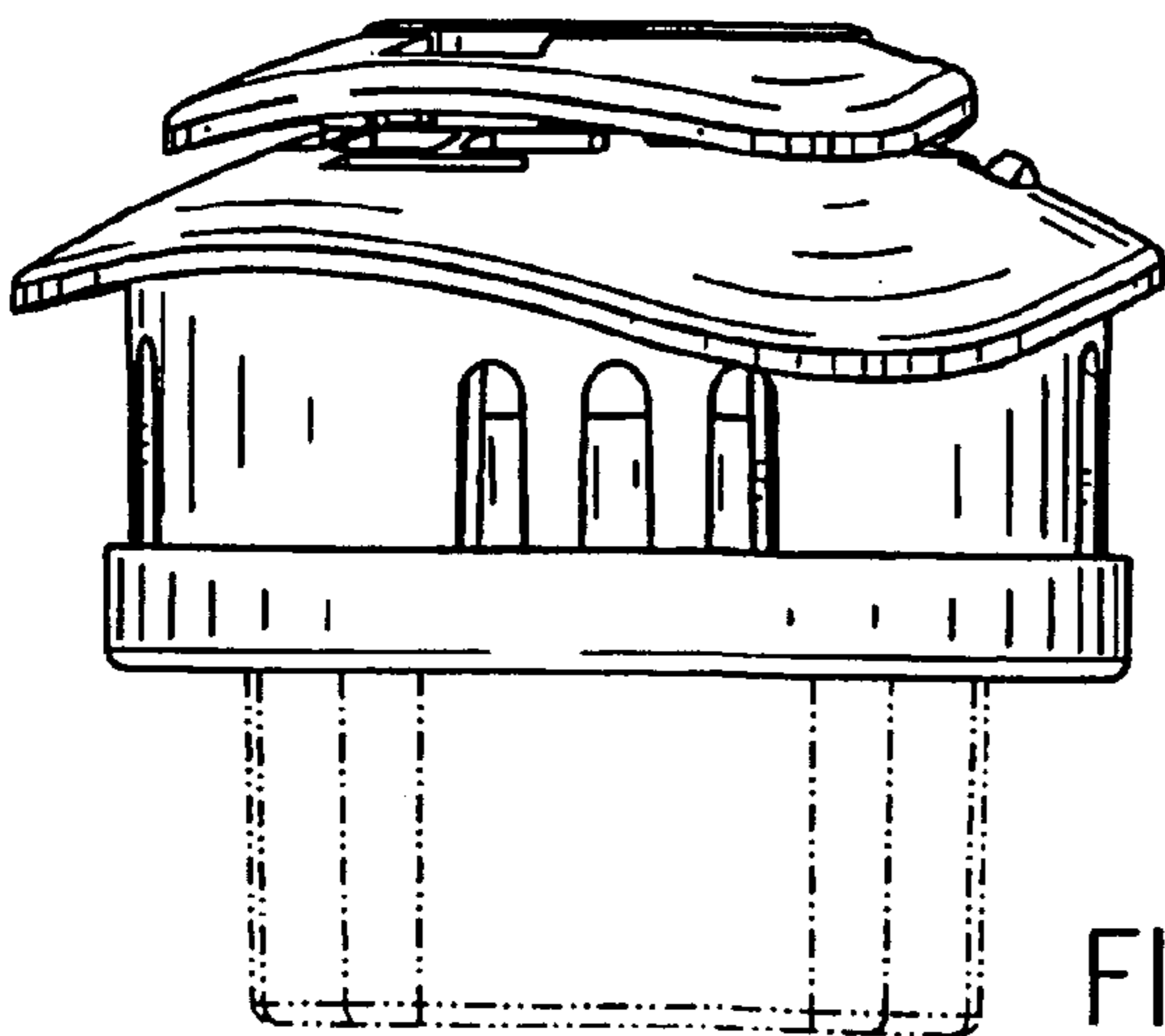

FIG. 21

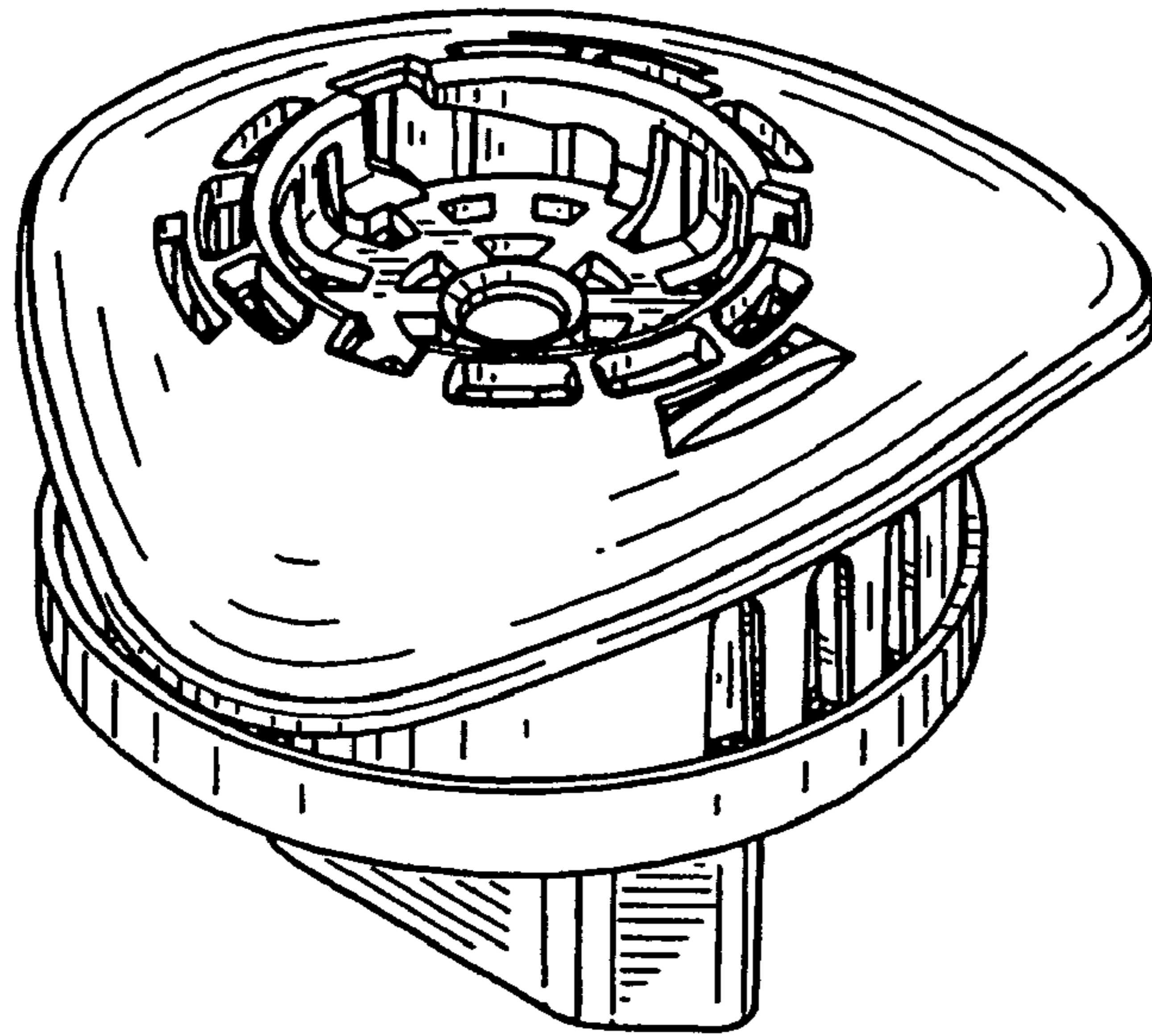

FIG. 22

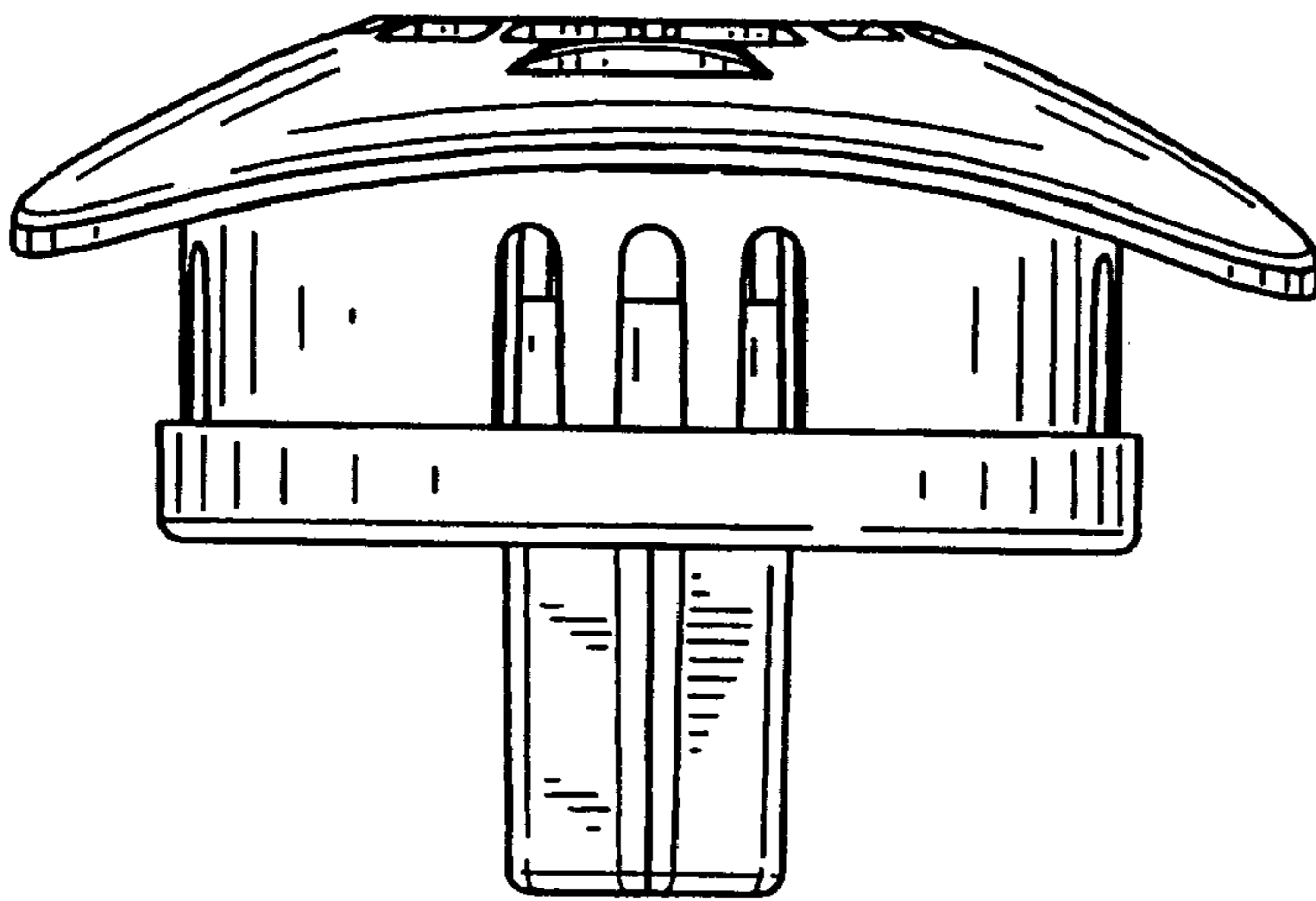

FIG. 23

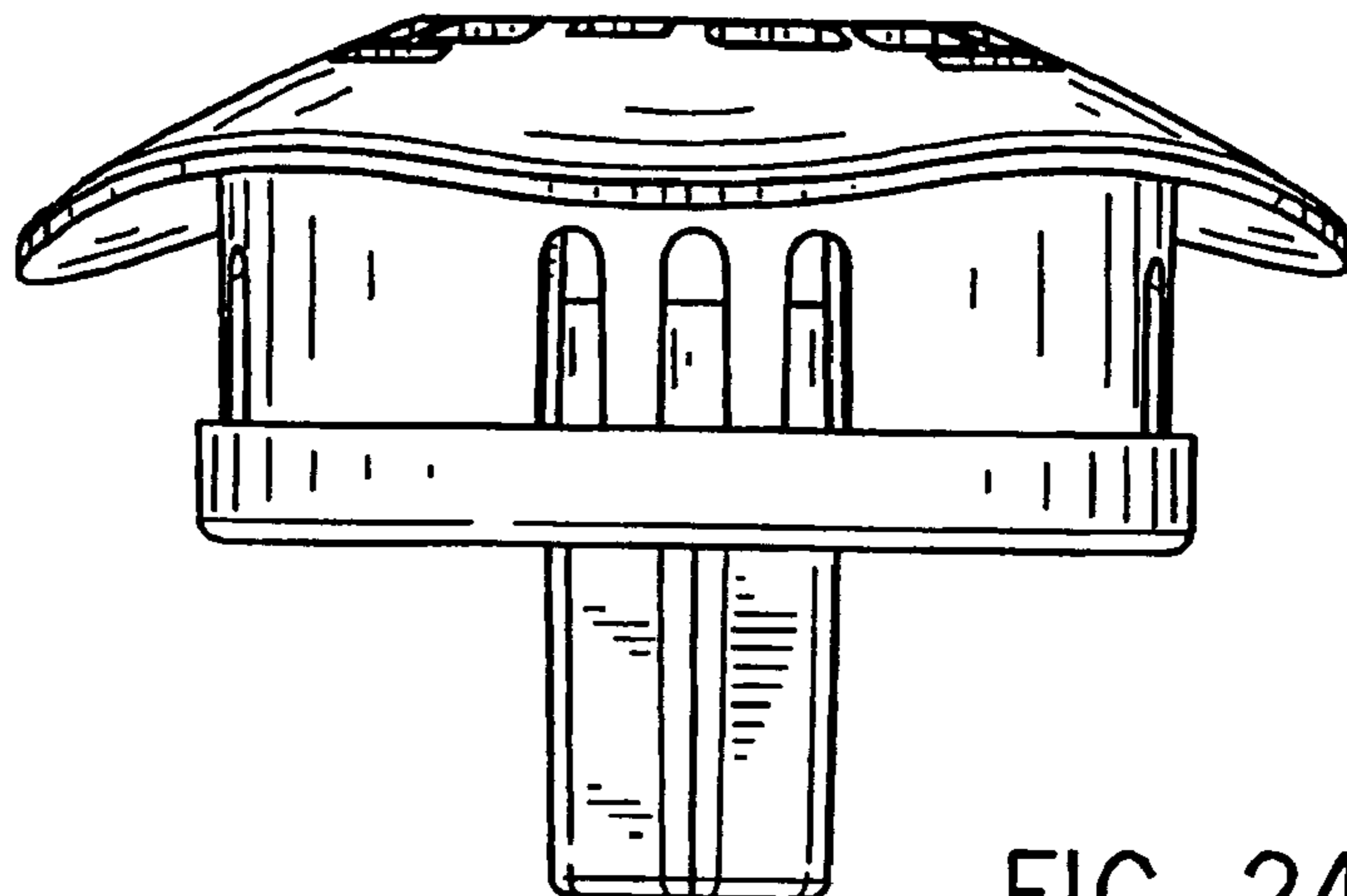

FIG. 24



FIG. 25

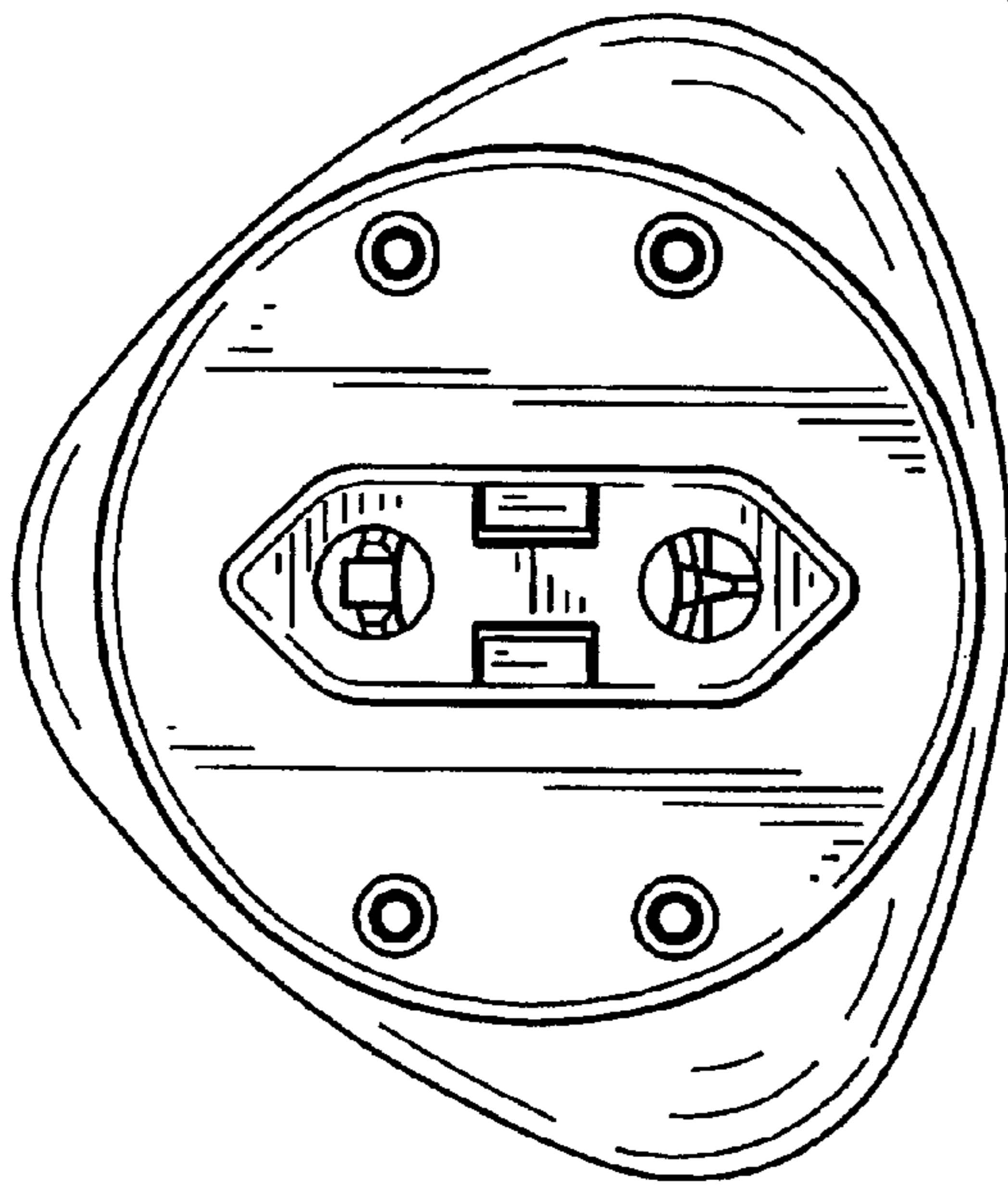
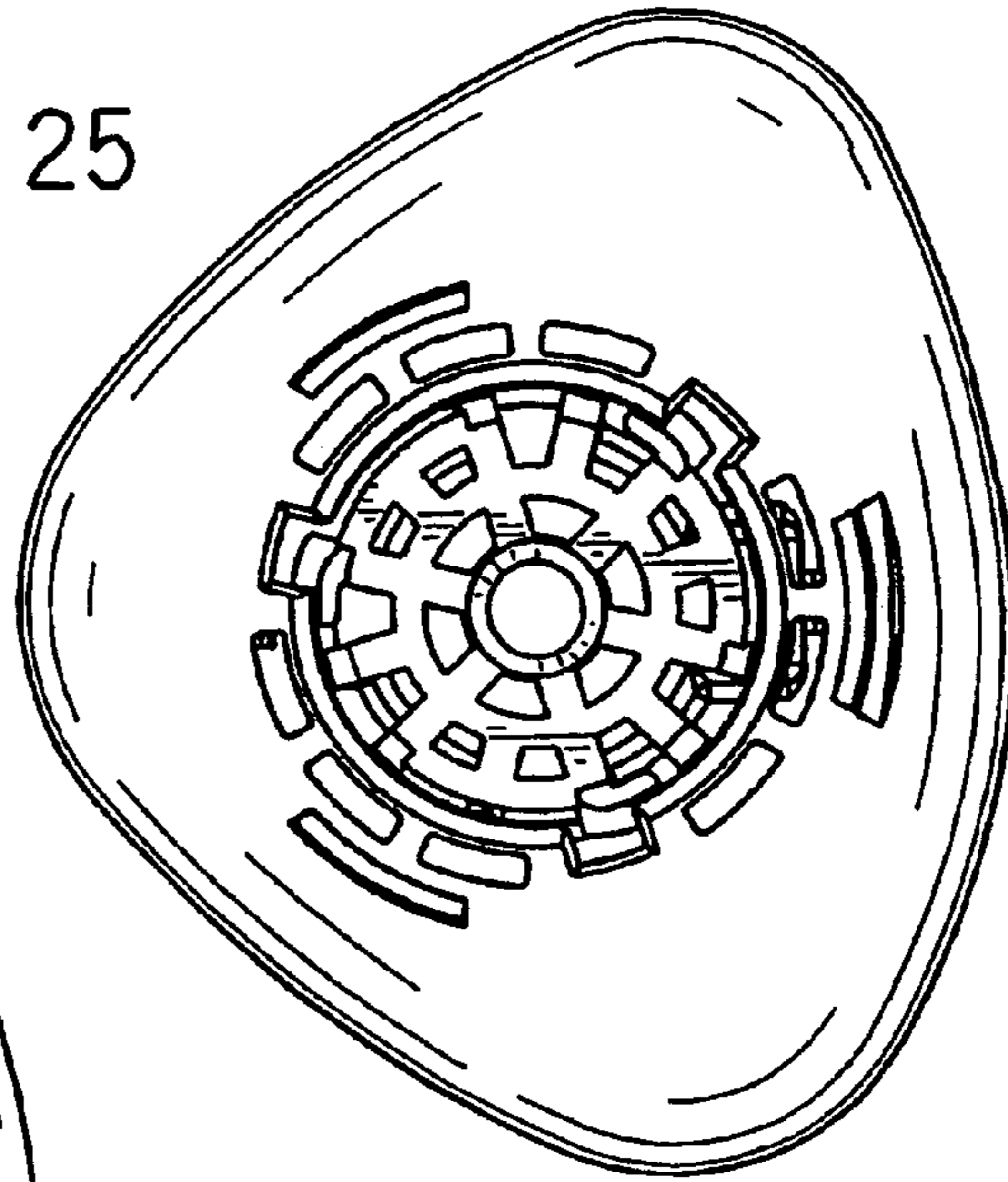

FIG. 26

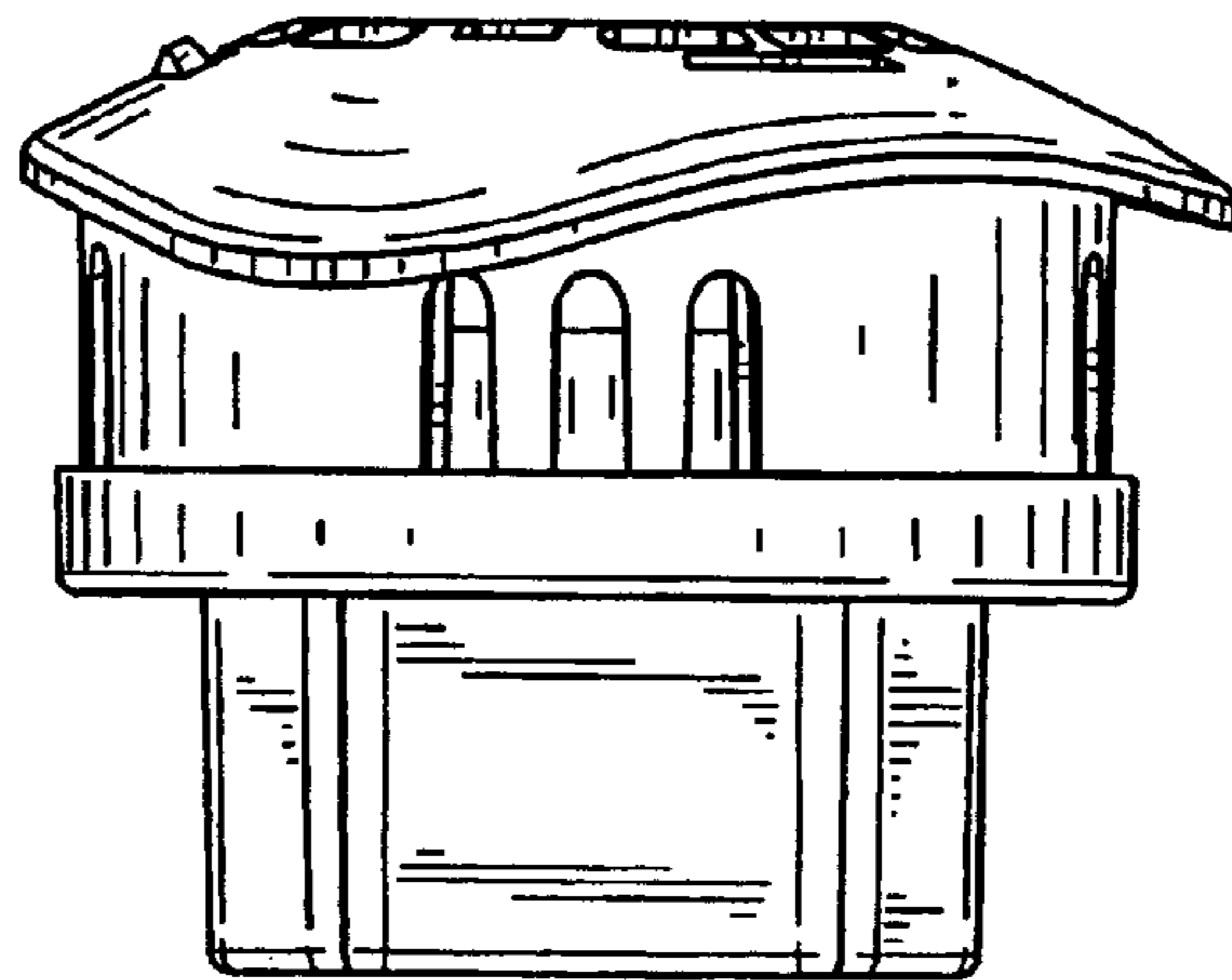

FIG. 27

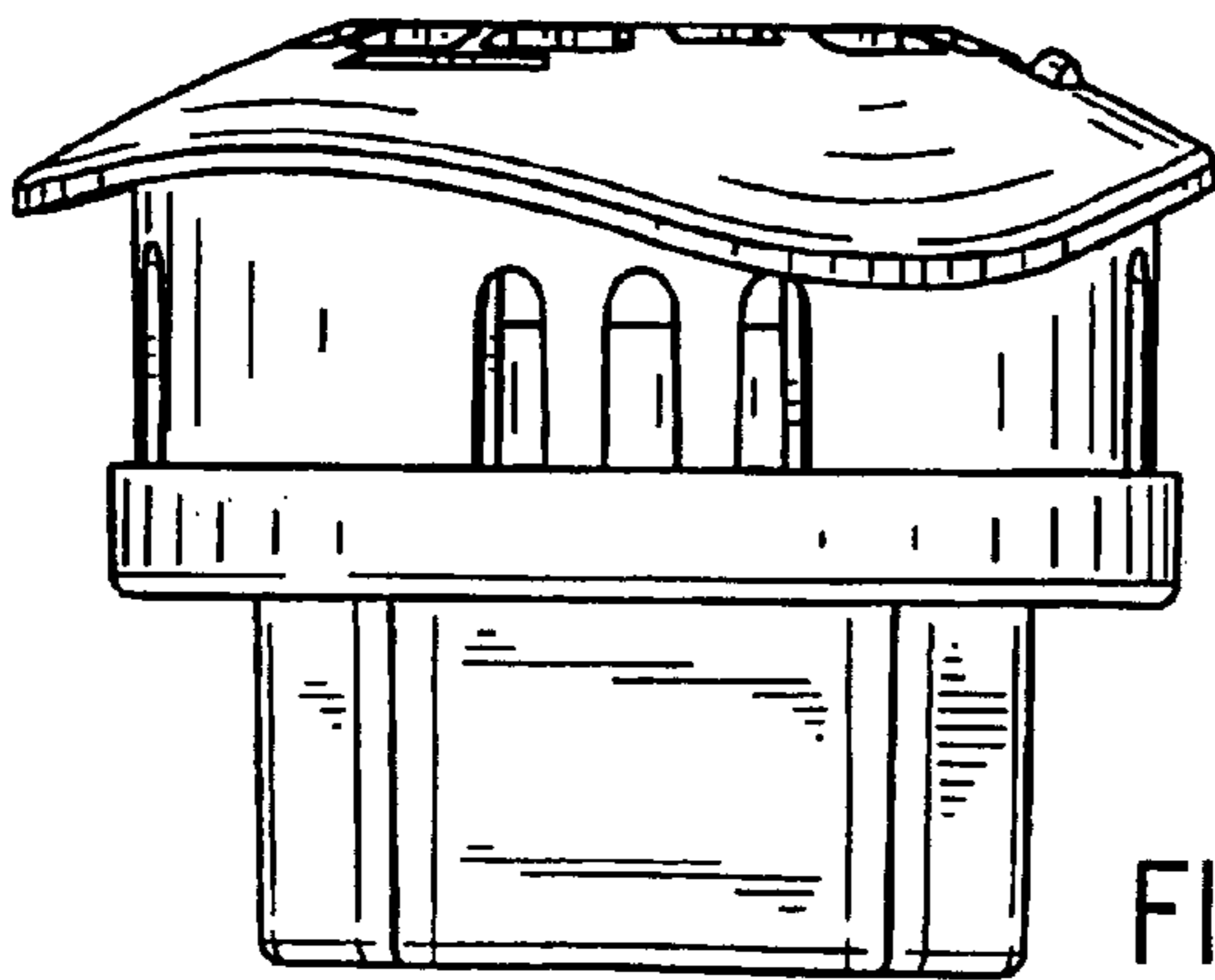

FIG. 28

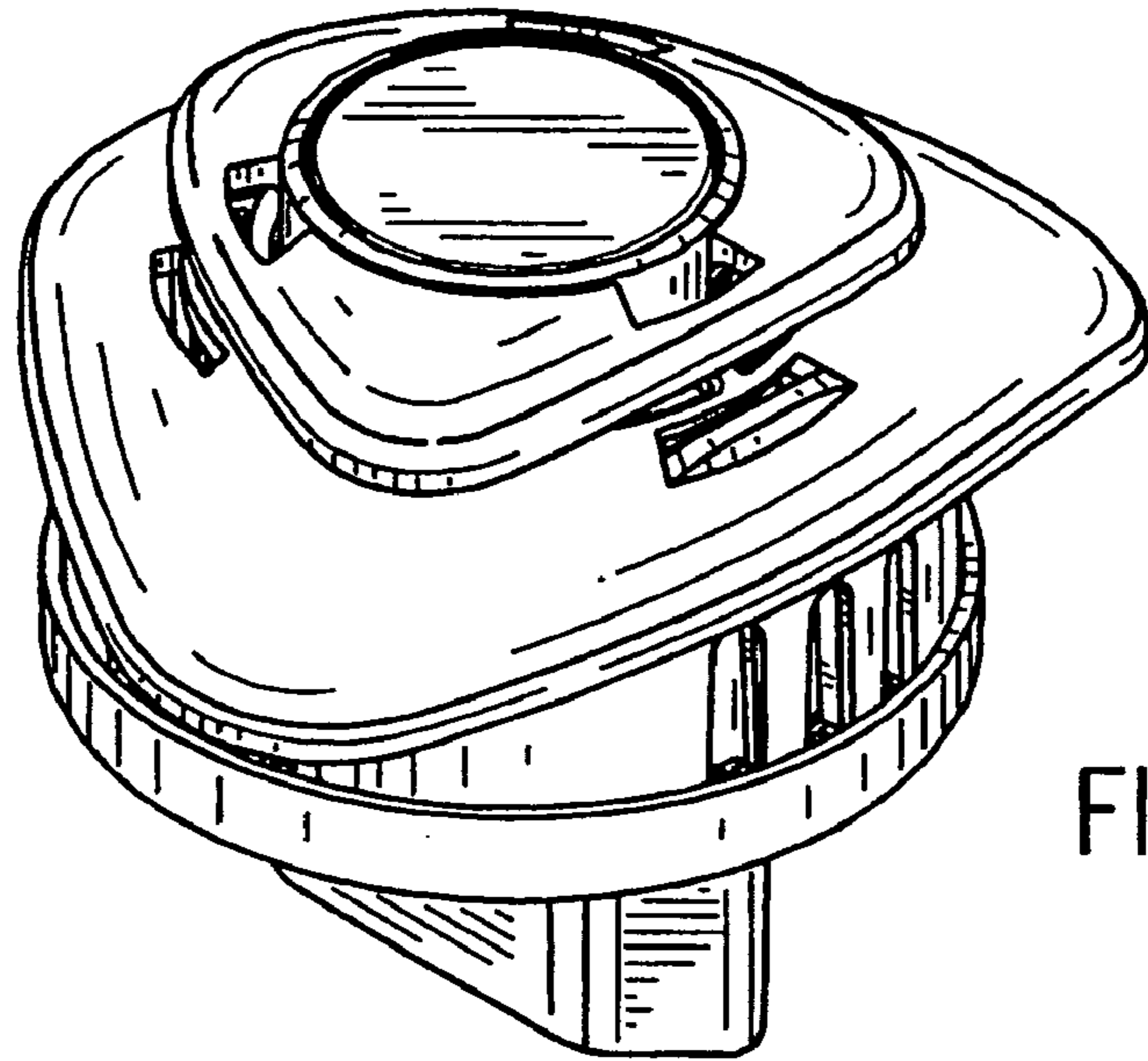

FIG. 29

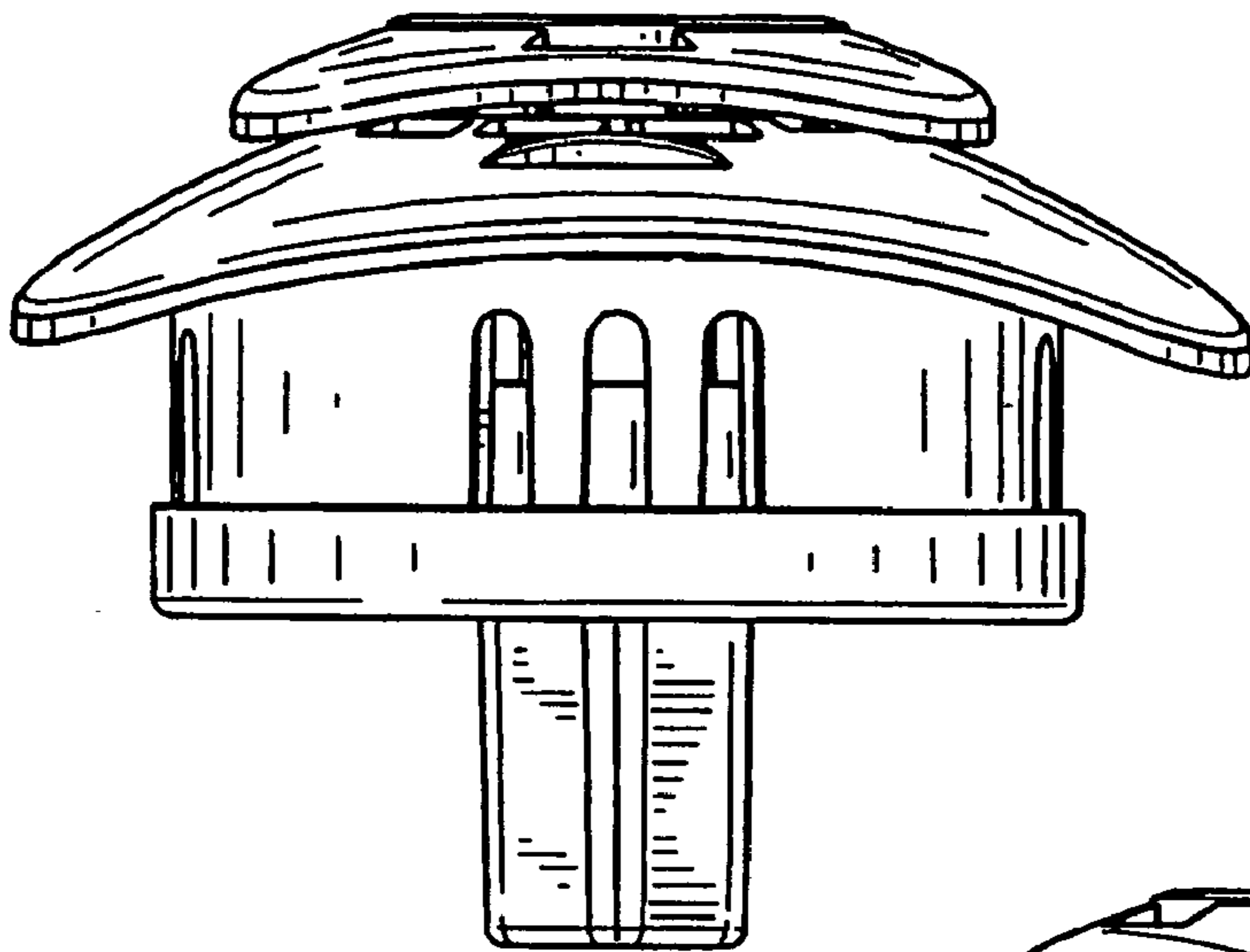

FIG. 30

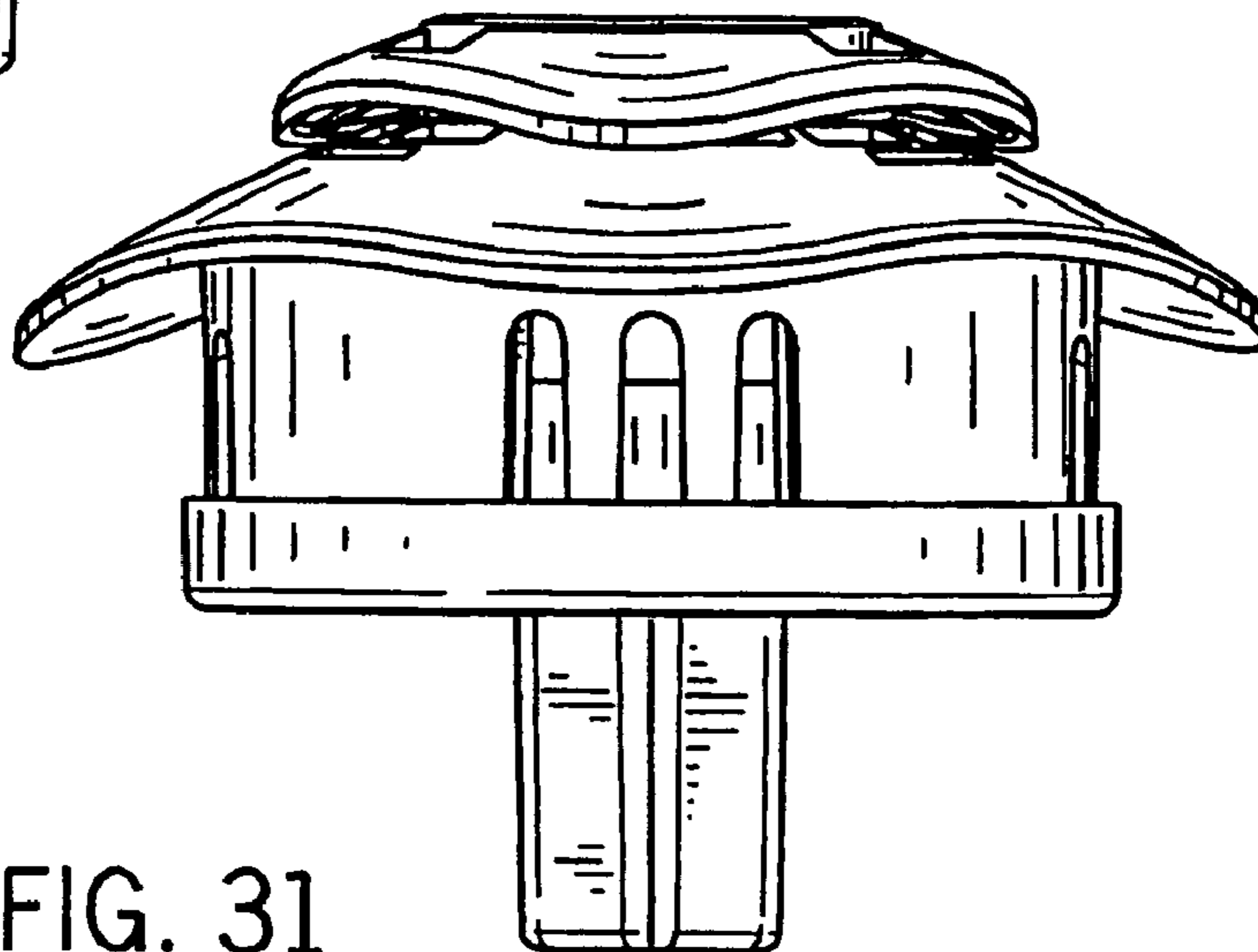

FIG. 31

FIG. 32

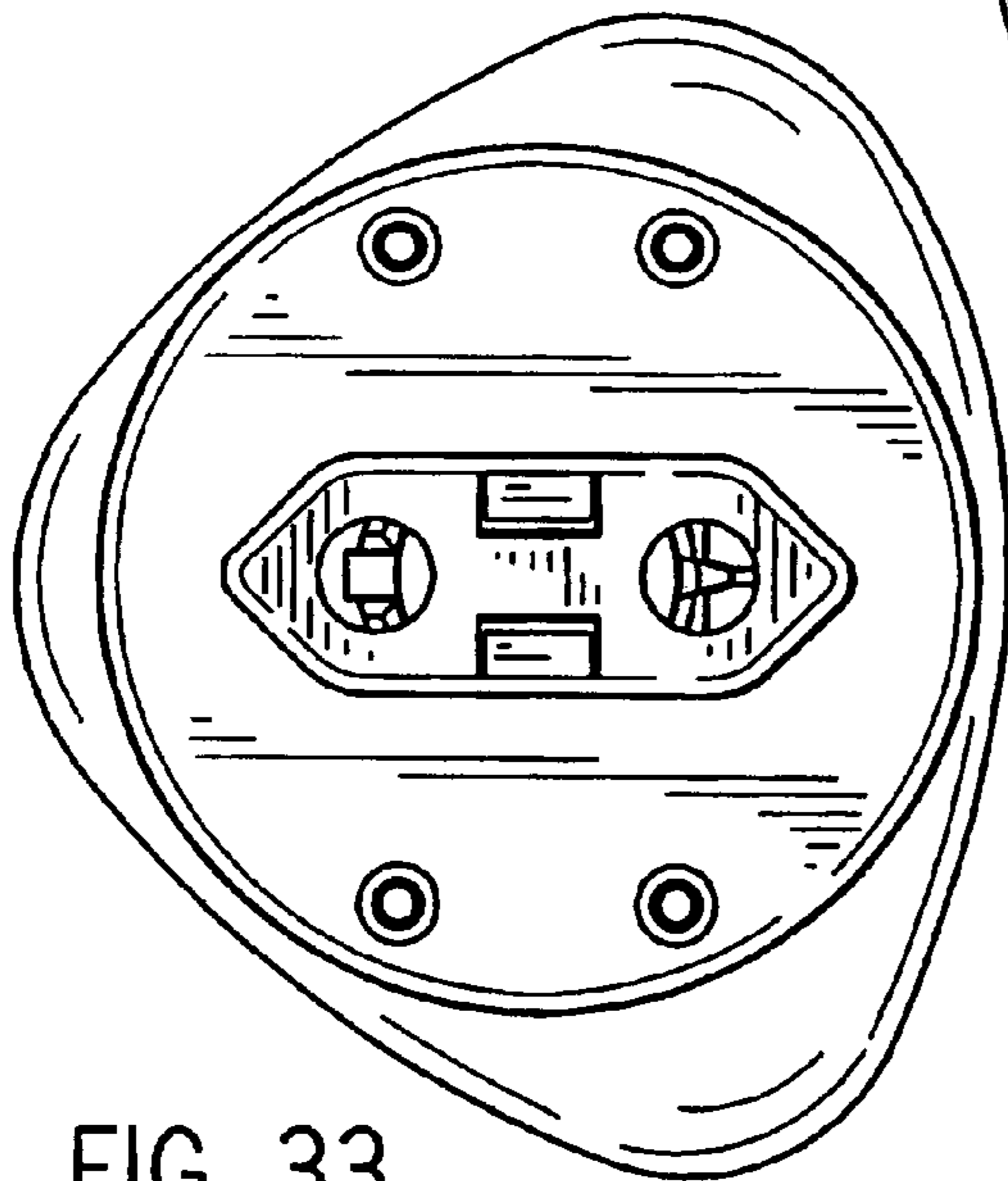
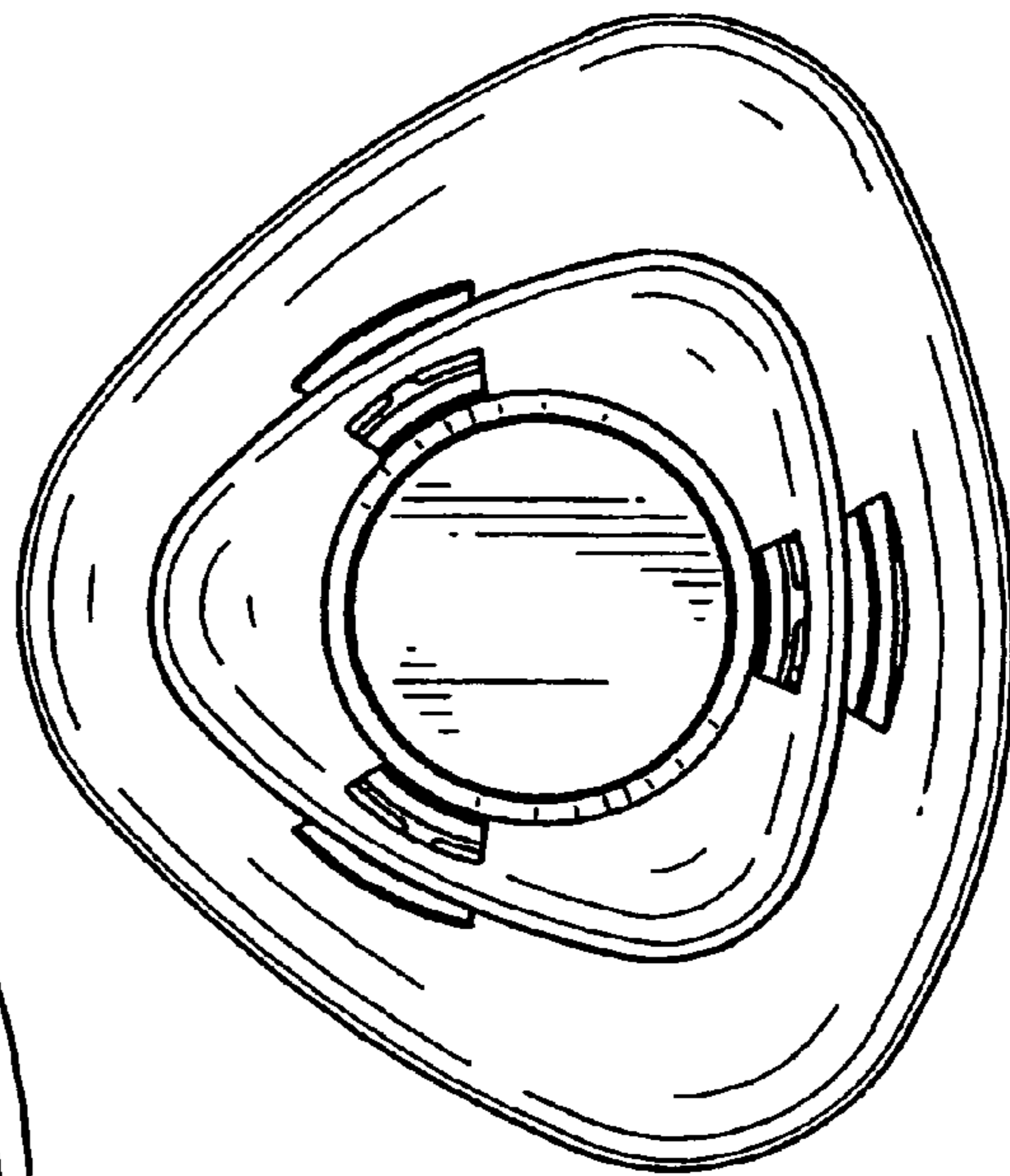

FIG. 33

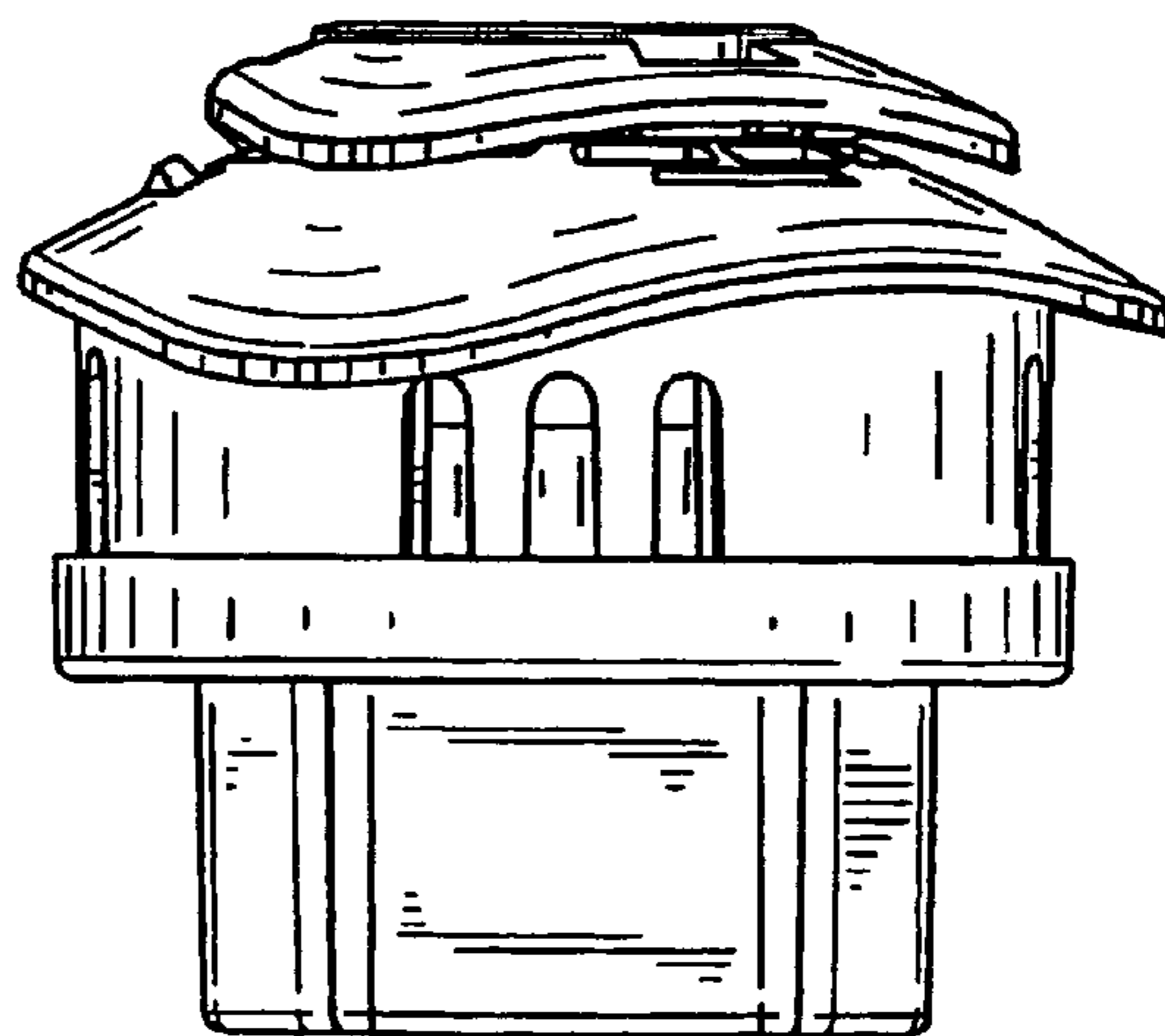

FIG. 34

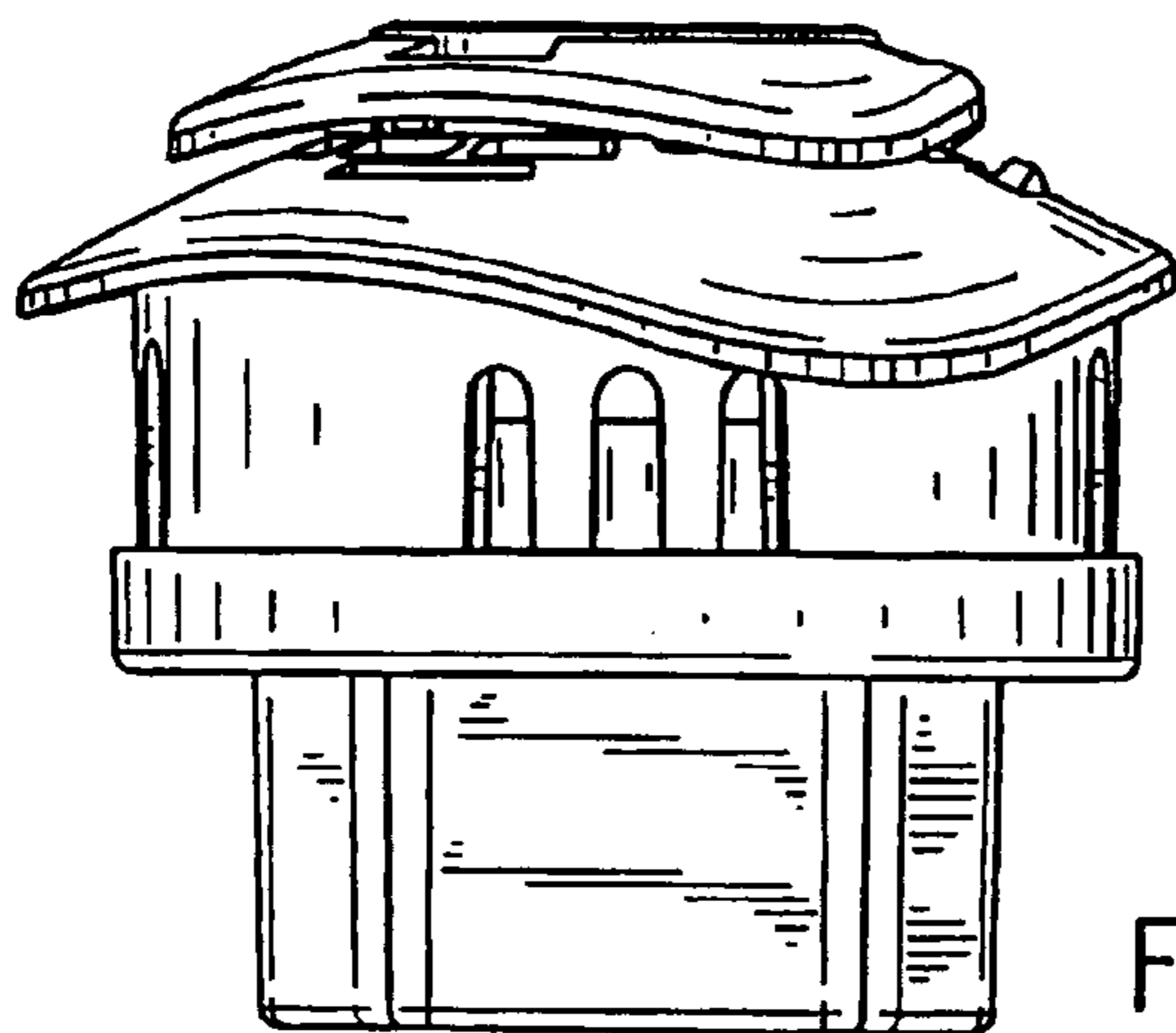

FIG. 35