



US00D554685S

(12) **United States Design Patent**  
**Ishikawa**

(10) **Patent No.:** **US D554,685 S**

(45) **Date of Patent:** **\*\* Nov. 6, 2007**

(54) **PROJECTOR**

(75) Inventor: **Takeshi Ishikawa**, Azumino (JP)

(73) Assignee: **Seiko Epson Corporation**, Tokyo (JP)

(\*\*) Term: **14 Years**

(21) Appl. No.: **29/262,039**

(22) Filed: **Jun. 26, 2006**

(30) **Foreign Application Priority Data**

Dec. 26, 2005 (JP) ..... 2005-037958

(51) **LOC (8) Cl.** ..... **16-02**

(52) **U.S. Cl.** ..... **D16/221; D16/225**

(58) **Field of Classification Search** ..... D16/200–206,  
D16/208, 213, 221–236; D21/514; 353/39,  
353/87, 115, 119, 122; 352/34, 242; 349/5,  
349/7–9, 58; 348/373–376, 14.01, 143; 358/471,  
358/434, 479, 909.1; 396/428, 419, 12–13,  
396/427

See application file for complete search history.

(56) **References Cited**

**U.S. PATENT DOCUMENTS**

D190,103 S *	4/1961	Stapsy	.....	D16/232
3,285,151 A *	11/1966	Black	.....	348/143
3,314,330 A *	4/1967	Finke	.....	353/87
3,542,463 A *	11/1970	Klein	.....	353/122
4,825,295 A *	4/1989	Ishikawa et al.	.....	348/375
4,939,580 A *	7/1990	Ishikawa et al.	.....	348/373
5,631,699 A *	5/1997	Saito	.....	348/211.6
D396,871 S *	8/1998	McNulty	.....	D16/232
D401,954 S *	12/1998	Oh et al.	.....	D16/232

5,966,176 A *	10/1999	Chow et al.	.....	348/373
D446,236 S *	8/2001	Chen	.....	D16/221
D446,534 S *	8/2001	Zimmer	.....	D16/203
D456,831 S *	5/2002	Mori et al.	.....	D16/225
6,695,452 B2 *	2/2004	Panasewicz et al.	.....	353/119
D500,511 S *	1/2005	Sybilrud	.....	D16/203
6,883,918 B2 *	4/2005	Yaniv	.....	353/122
D506,489 S *	6/2005	Owada	.....	D16/203
7,046,297 B2 *	5/2006	Chou	.....	348/375
7,182,472 B2 *	2/2007	Vitantonio et al.	.....	353/99
2005/0057542 A1 *	3/2005	Plut	.....	345/204
2005/0162545 A1 *	7/2005	Jeon	.....	348/373

\* cited by examiner

*Primary Examiner*—Ian Simmons

*Assistant Examiner*—Wan Laymon

(74) *Attorney, Agent, or Firm*—Oliff & Berridge, PLC

(57) **CLAIM**

The ornamental design for a projector, as shown and described.

**DESCRIPTION**

FIG. 1 is a perspective view thereof;

FIG. 2 is a front view thereof;

FIG. 3 is a rear view thereof;

FIG. 4 is a left-side view thereof;

FIG. 5 is a right-side view thereof;

FIG. 6 is a top view thereof; and,

FIG. 7 is a bottom view thereof.

The broken lines are for illustrative purposes only and form no part of the claimed design.

**1 Claim, 7 Drawing Sheets**

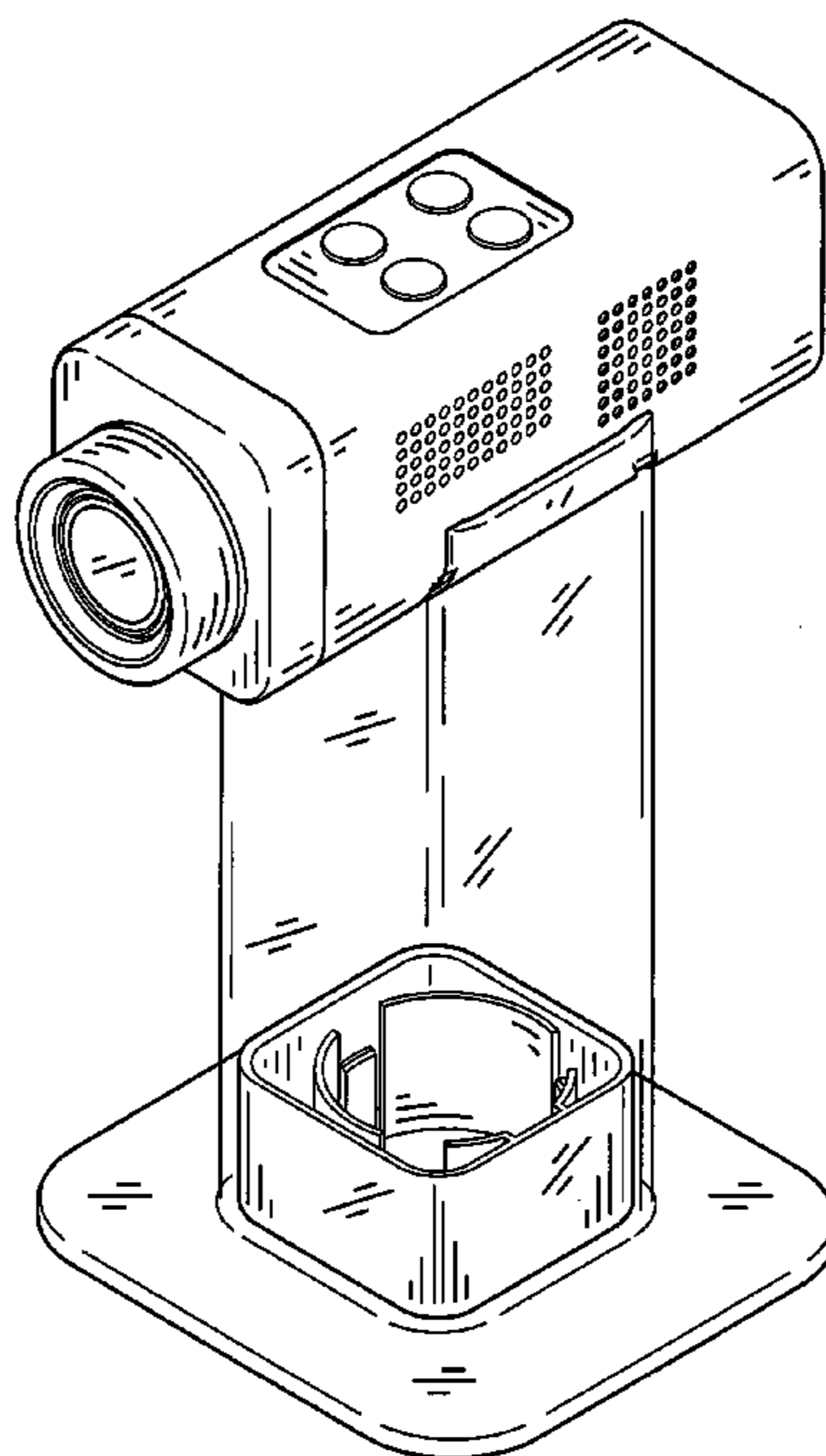

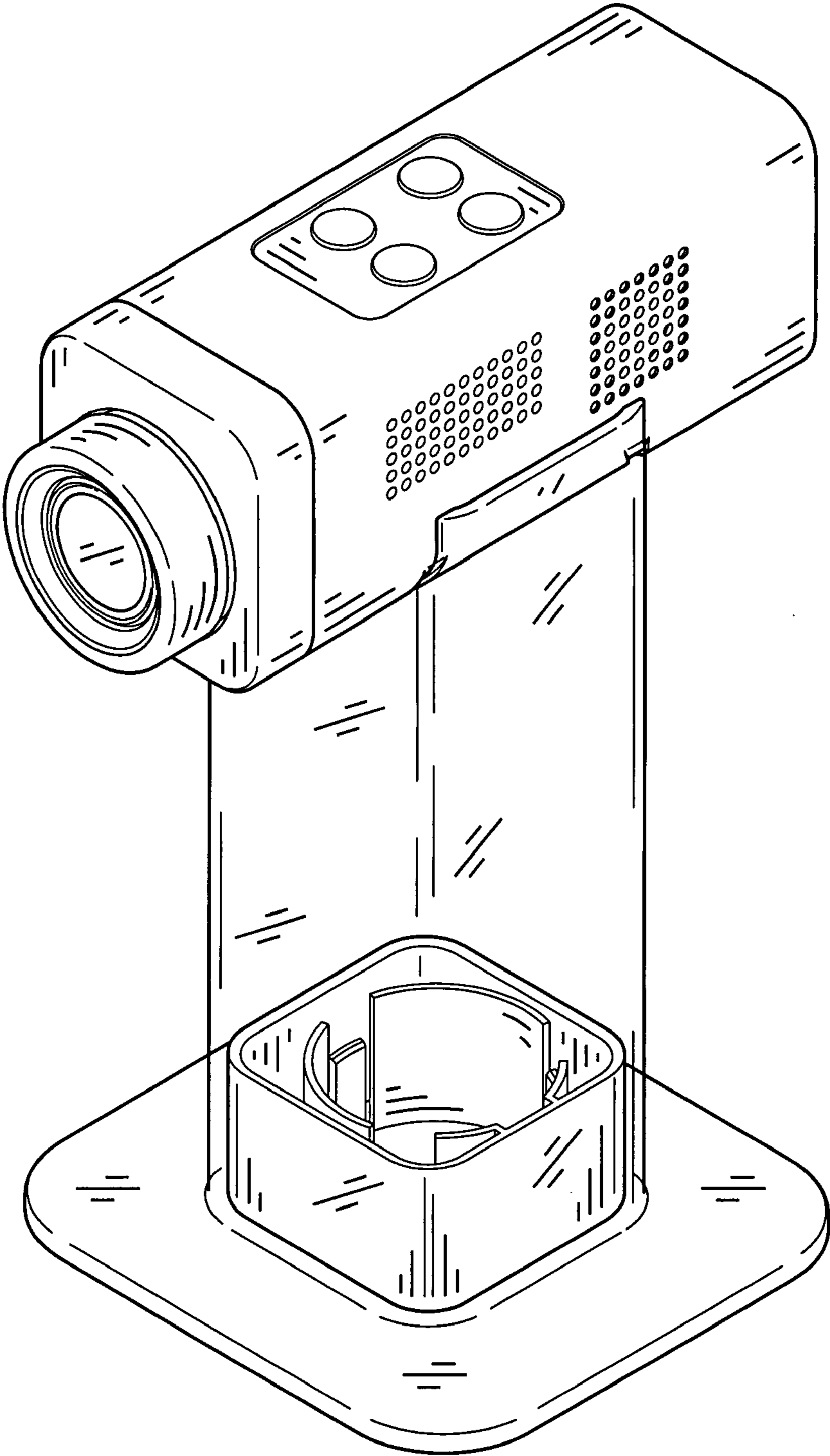

FIG. 1

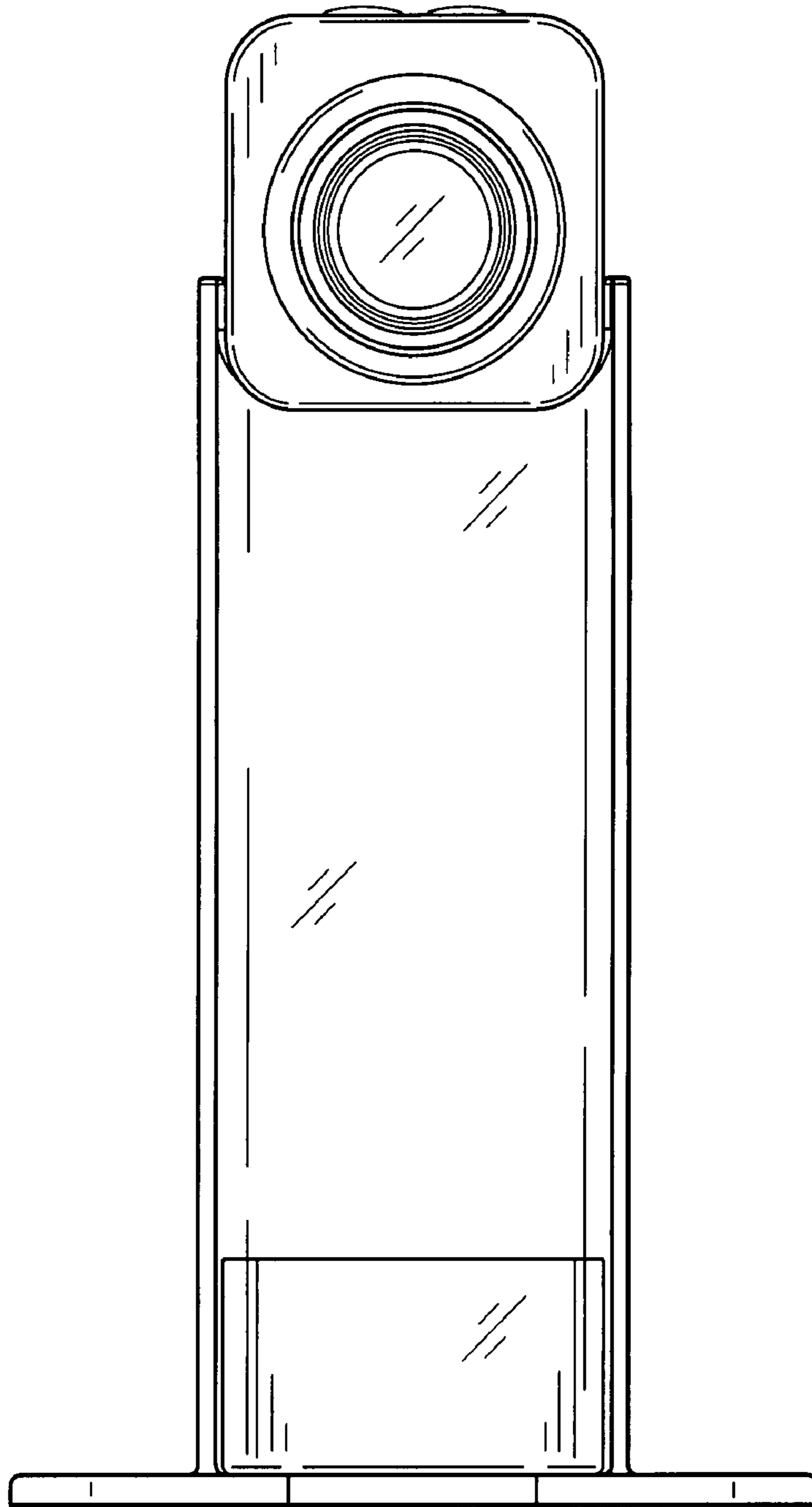

FIG. 2

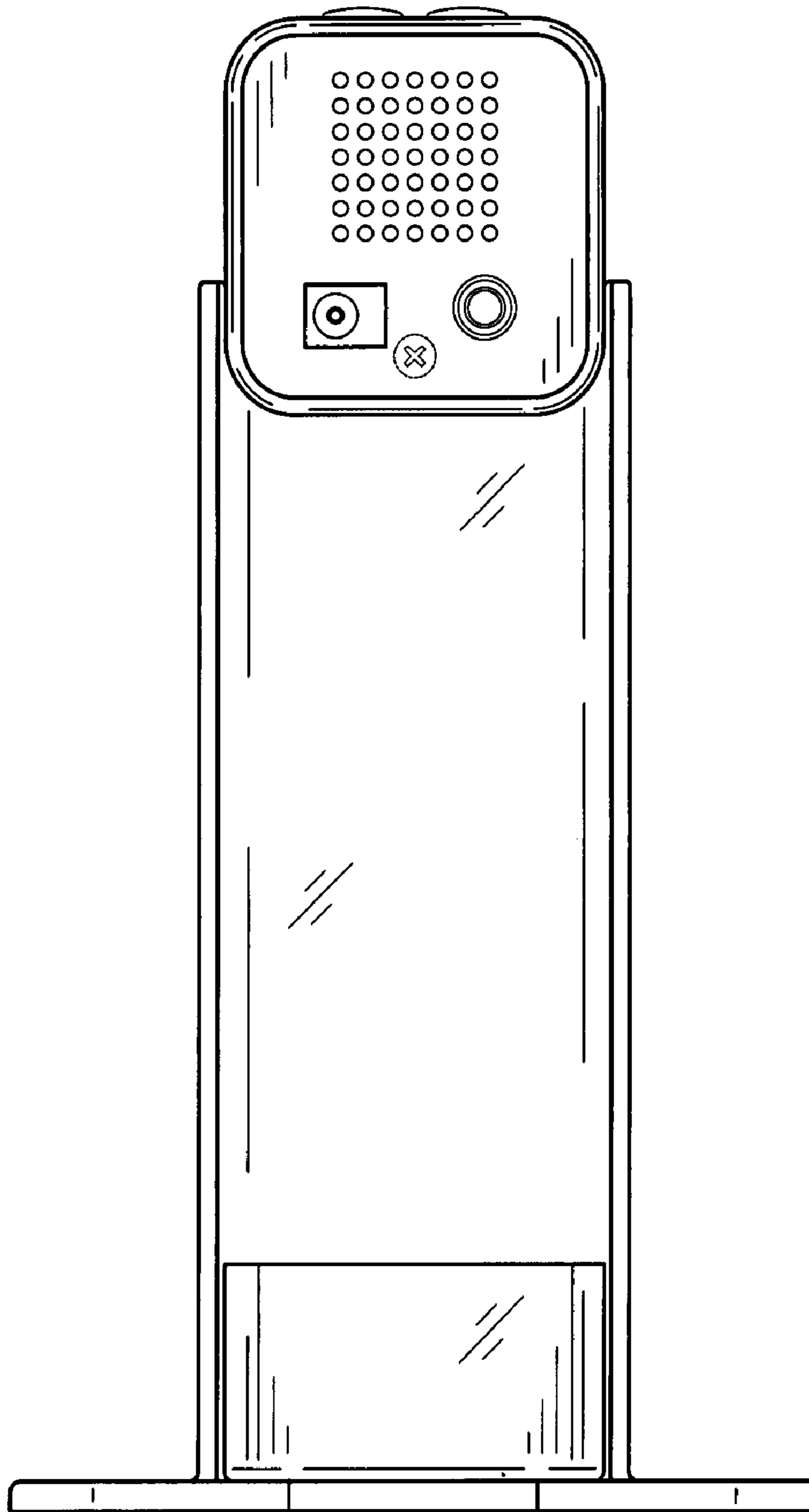

FIG. 3

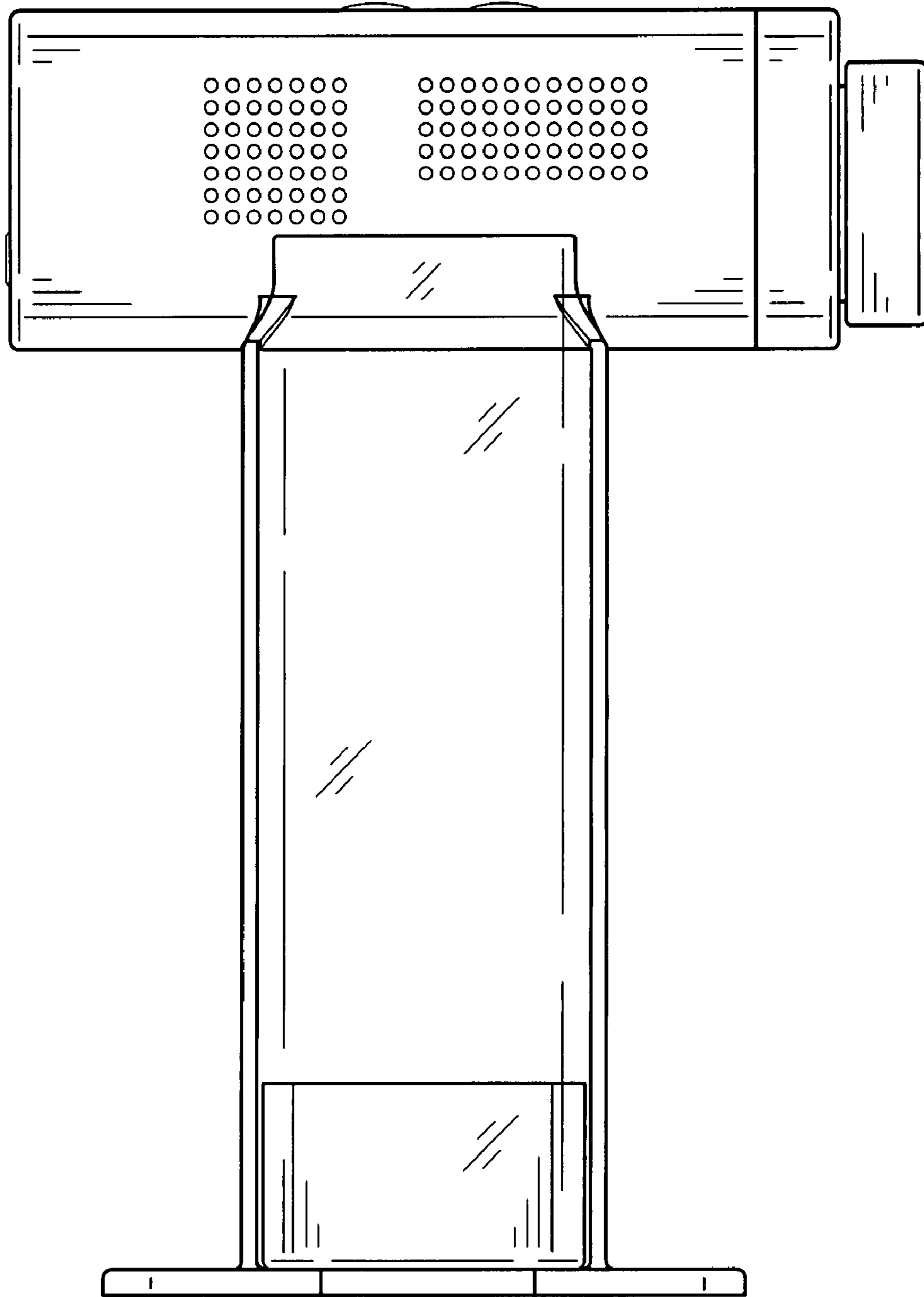

FIG. 4

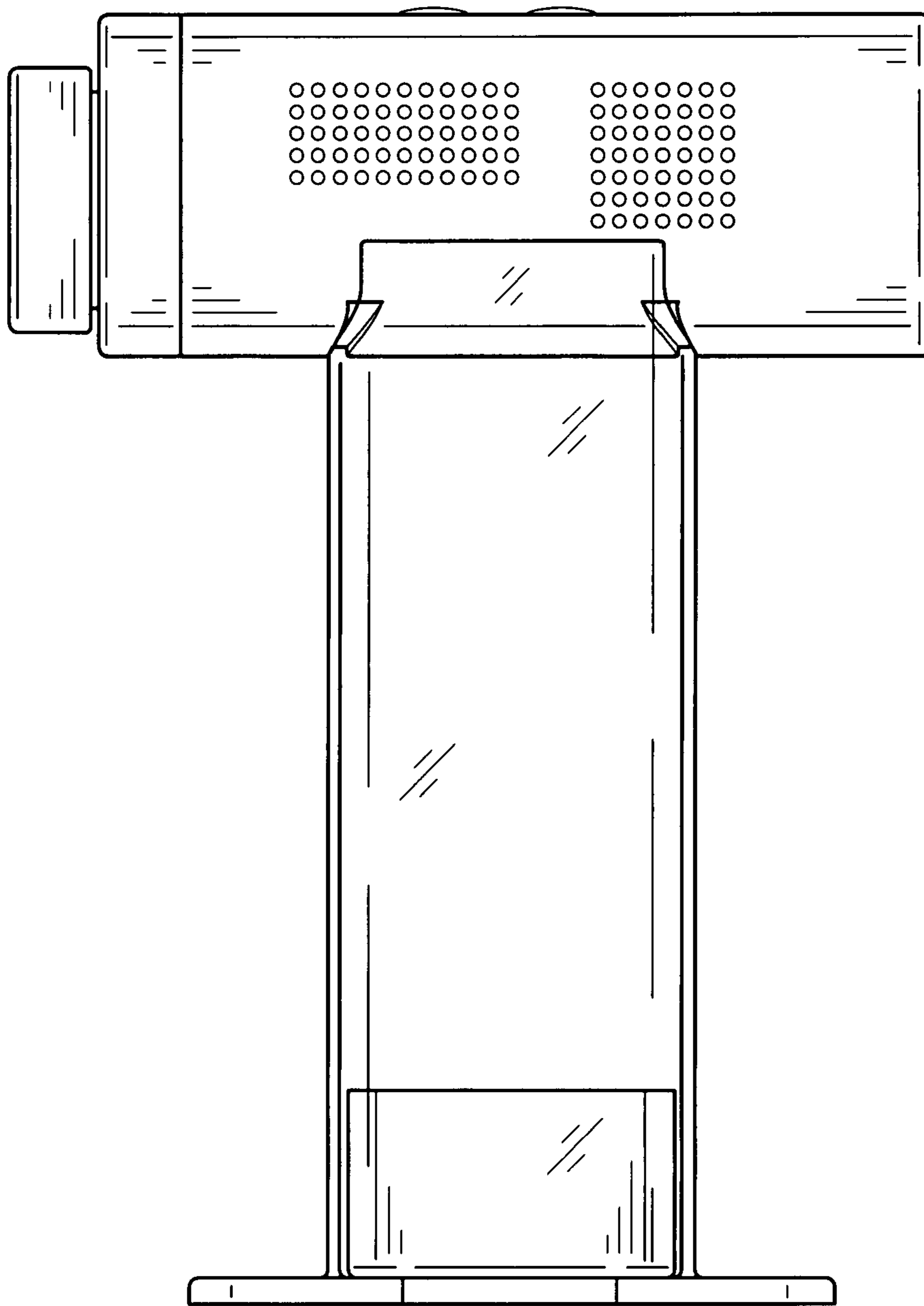

FIG. 5

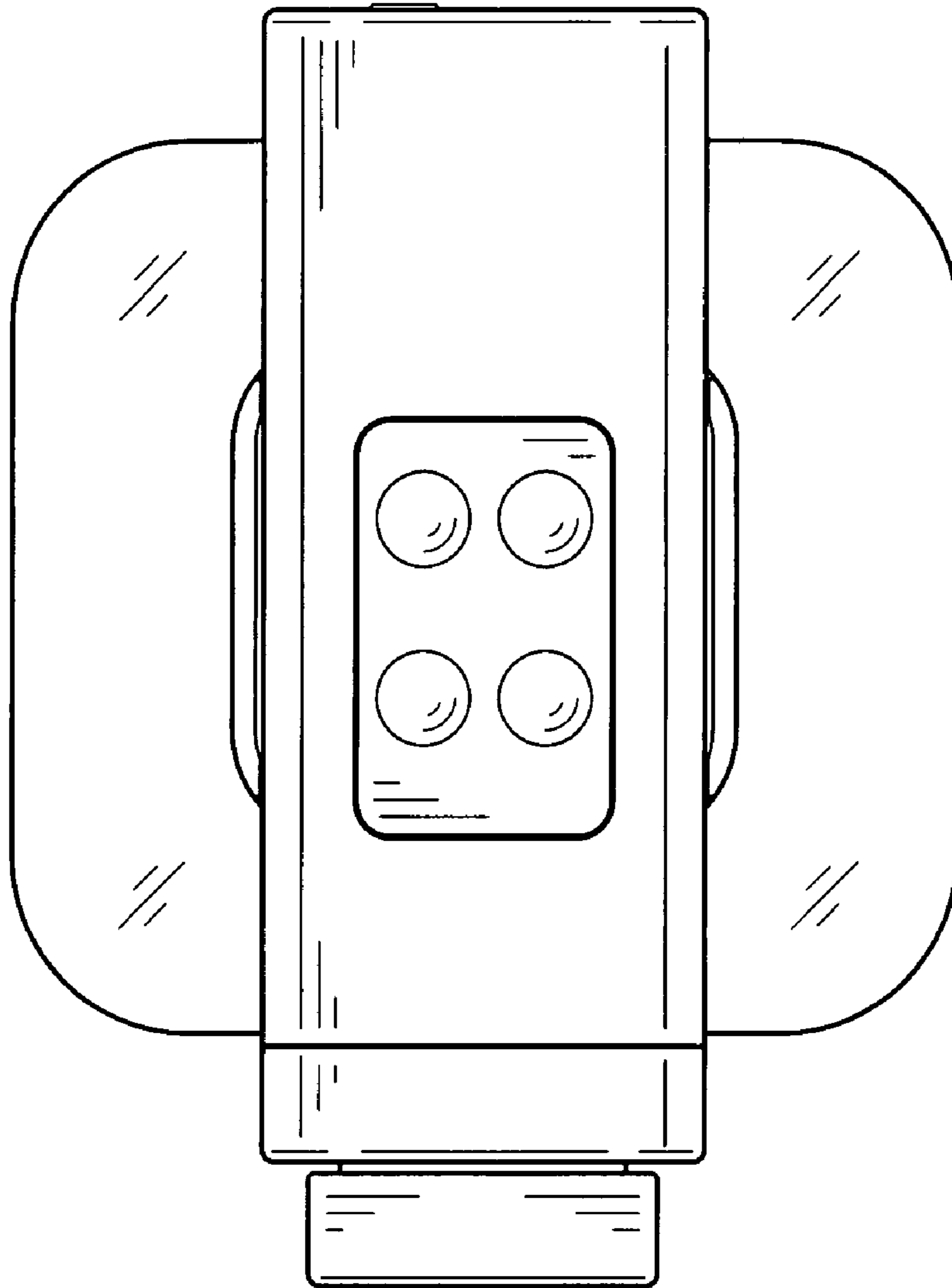

FIG. 6

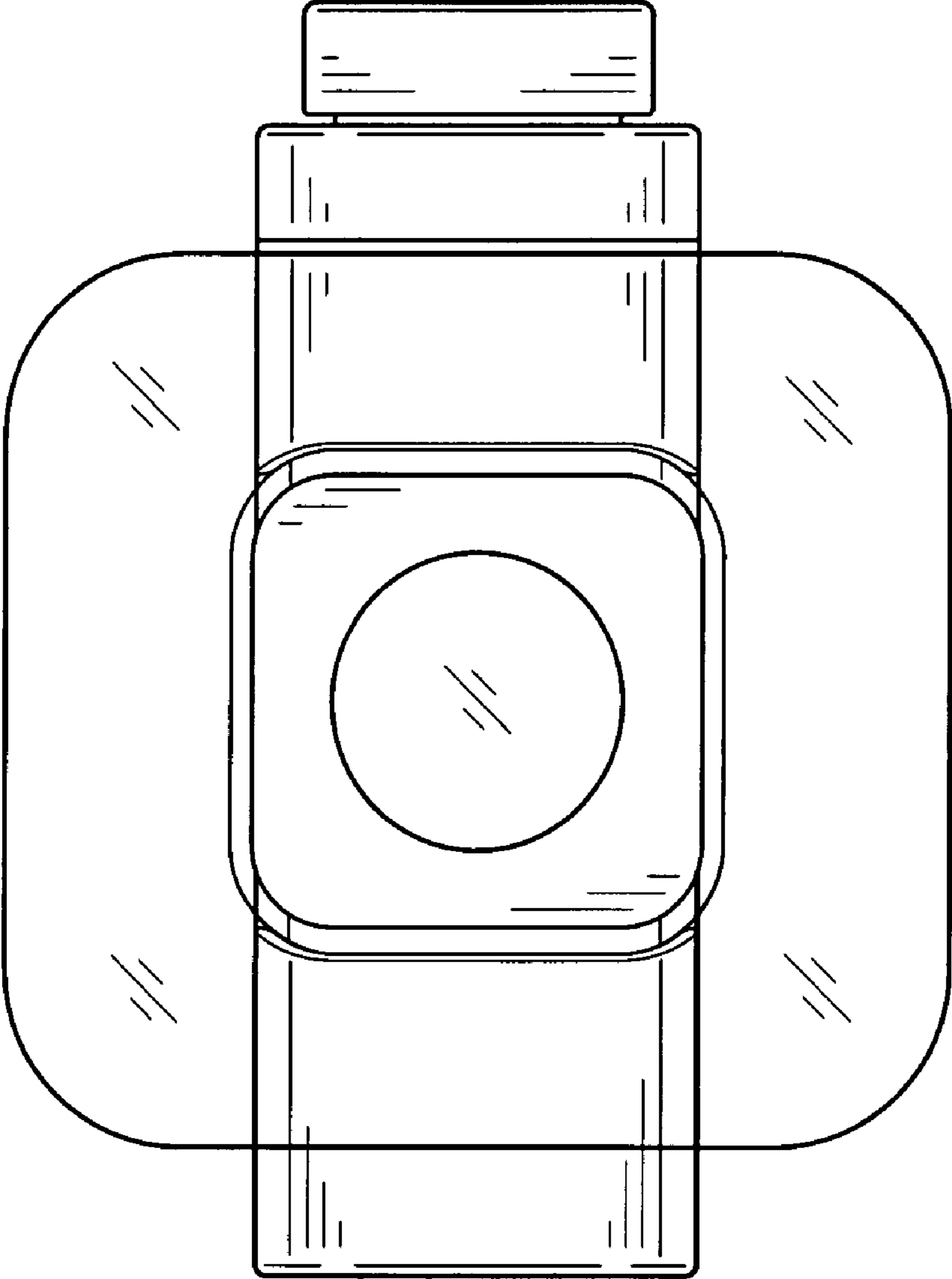

FIG. 7