



US00D554675S

(12) **United States Design Patent** (10) **Patent No.:** **US D554,675 S**  
**Baker, Jr.** (45) **Date of Patent:** **\*\* Nov. 6, 2007**

(54) **PRIMARY DRIVE CHAIN HOUSING**

(76) Inventor: **Bert E. Baker, Jr.**, 4280 Redbud Trail,  
Williamston, MI (US) 48895

(\*\*) Term: **14 Years**

(21) Appl. No.: **29/273,725**

(22) Filed: **Mar. 12, 2007**

(51) **LOC (8) Cl.** ..... **15-09**

(52) **U.S. Cl.** ..... **D15/148**

(58) **Field of Classification Search** ..... D15/1,  
D15/5, 148, 149; 74/606 R; 123/90.19;  
464/170-178; 474/101, 111, 135, 140, 144-146,  
474/150, 231

See application file for complete search history.

(56) **References Cited**

**U.S. PATENT DOCUMENTS**

1,722,581	A *	7/1929	Klaucke	.....	474/91
3,707,092	A *	12/1972	Piech	.....	474/101
5,730,674	A *	3/1998	Ott	.....	474/111
5,957,796	A *	9/1999	McLean	.....	474/146
2002/0071692	A1 *	6/2002	Thompson et al.	.....	399/98
2004/0118240	A1 *	6/2004	Young	.....	74/606 R
2005/0229742	A1 *	10/2005	Komura et al.	.....	74/606 R
2007/0129190	A1 *	6/2007	Sloan, Jr.	.....	474/144

\* cited by examiner

*Primary Examiner*—Antoine D. Davis

*Assistant Examiner*—Patricia Palasik

(74) *Attorney, Agent, or Firm*—Knechtel, Demeur & Samlan

(57) **CLAIM**

The ornamental design for a primary drive chain housing, as shown and described.

**DESCRIPTION**

FIG. 1 is a front perspective view of the primary drive chain housing showing the new design thereof;

FIG. 2 is a front perspective view thereof as seen from the bottom;

FIG. 3 is a front elevational view thereof;

FIG. 4 is a left side elevational view thereof;

FIG. 5 is a right side elevational view thereof;

FIG. 6 is a bottom elevational view thereof;

FIG. 7 is a top elevational view thereof; and,

FIG. 8 is a rear elevational view thereof.

The broken lines showing various other features of the primary drive chain housing throughout FIGS. 1 through 8 are for illustrative purposes only and form no part of the claimed design.

**1 Claim, 8 Drawing Sheets**

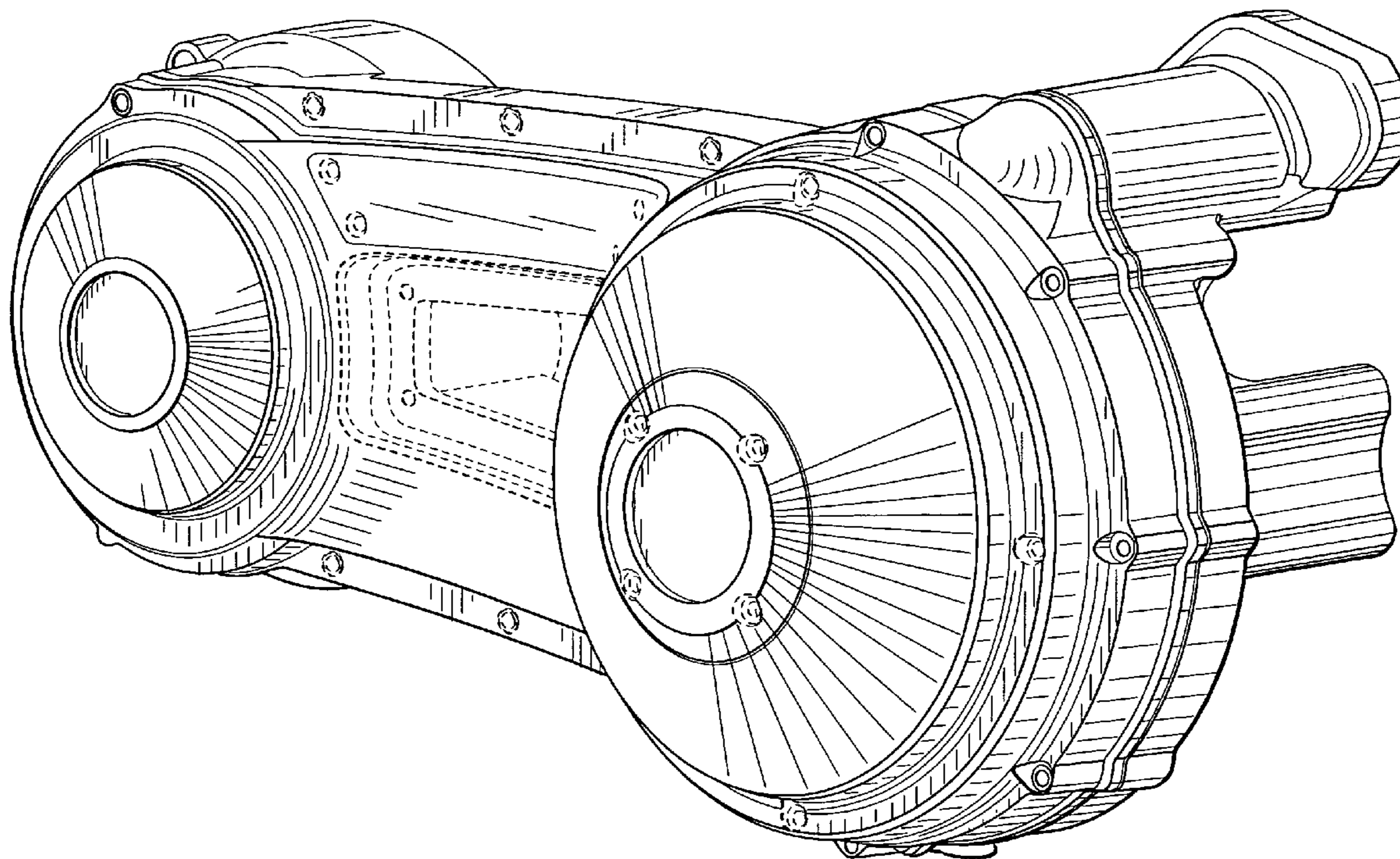
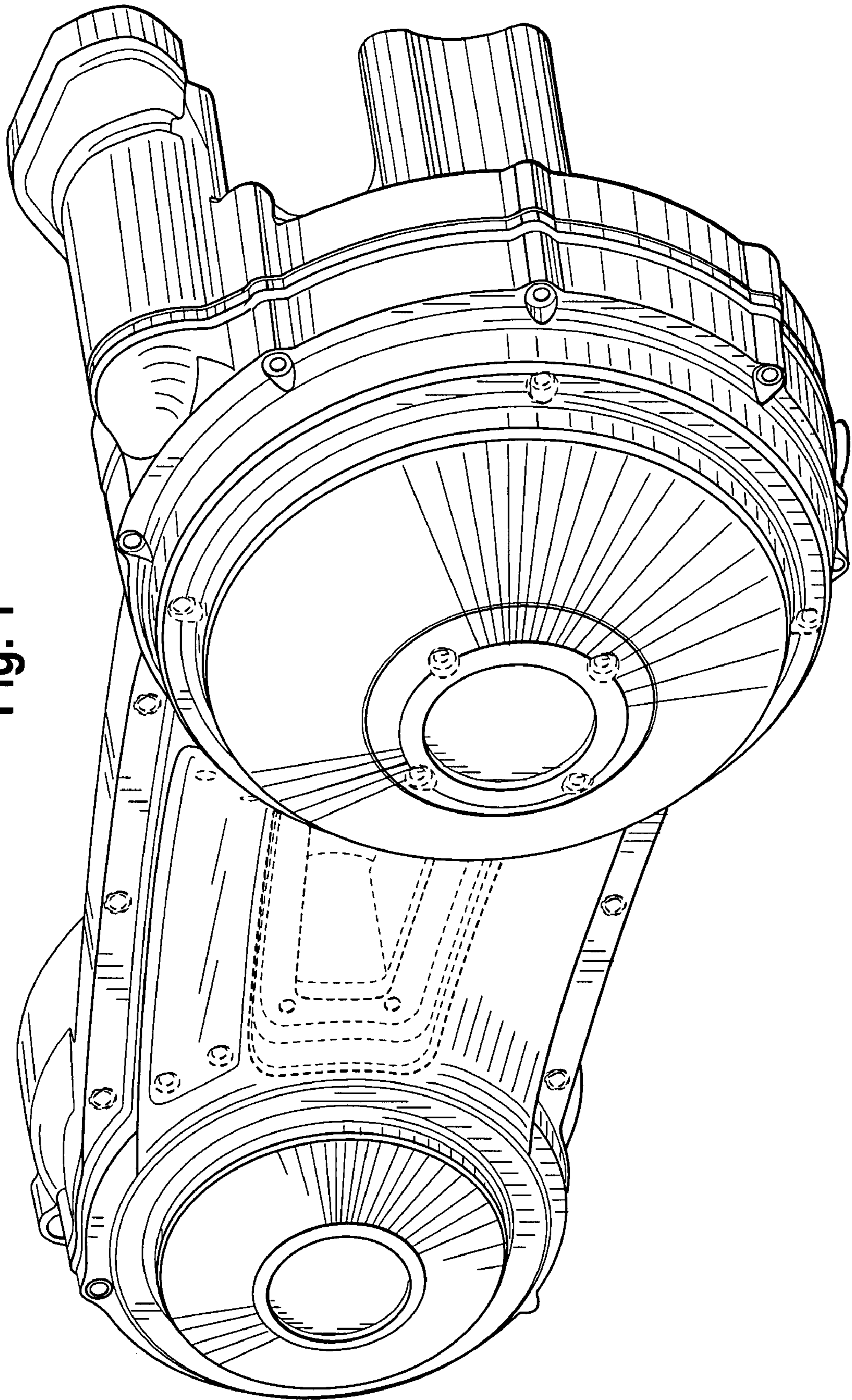

Fig. 1



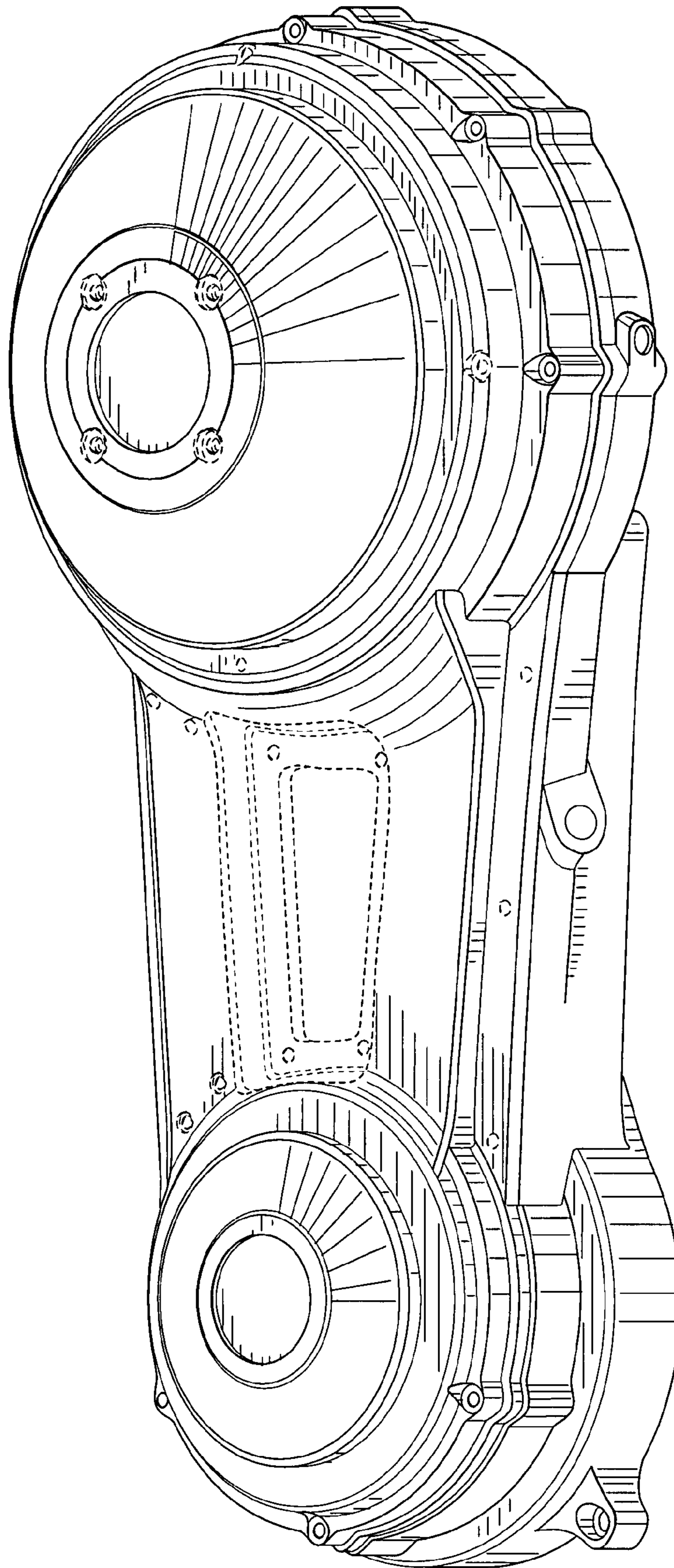

Fig. 2

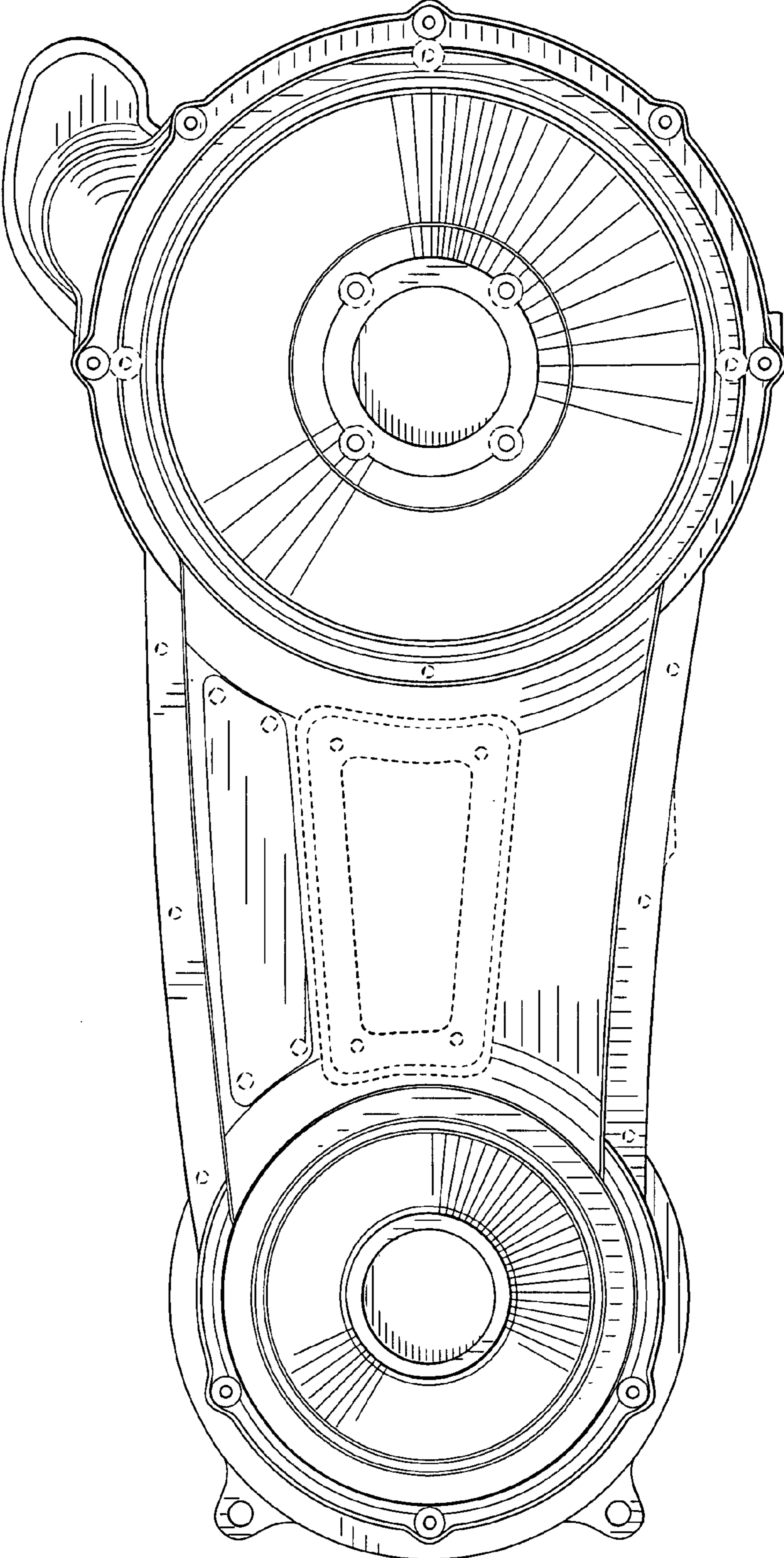

Fig. 3

Fig. 4

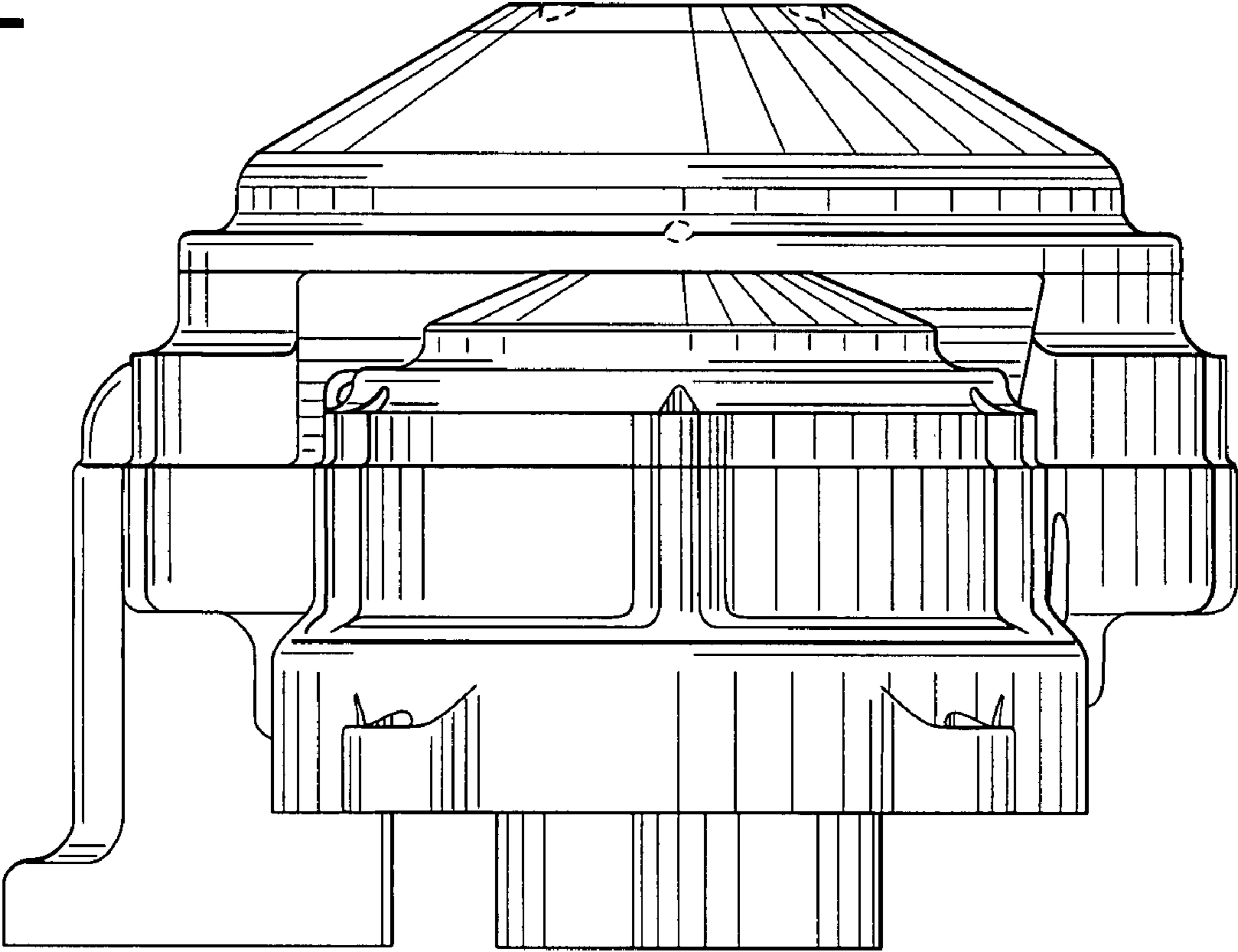

Fig. 5

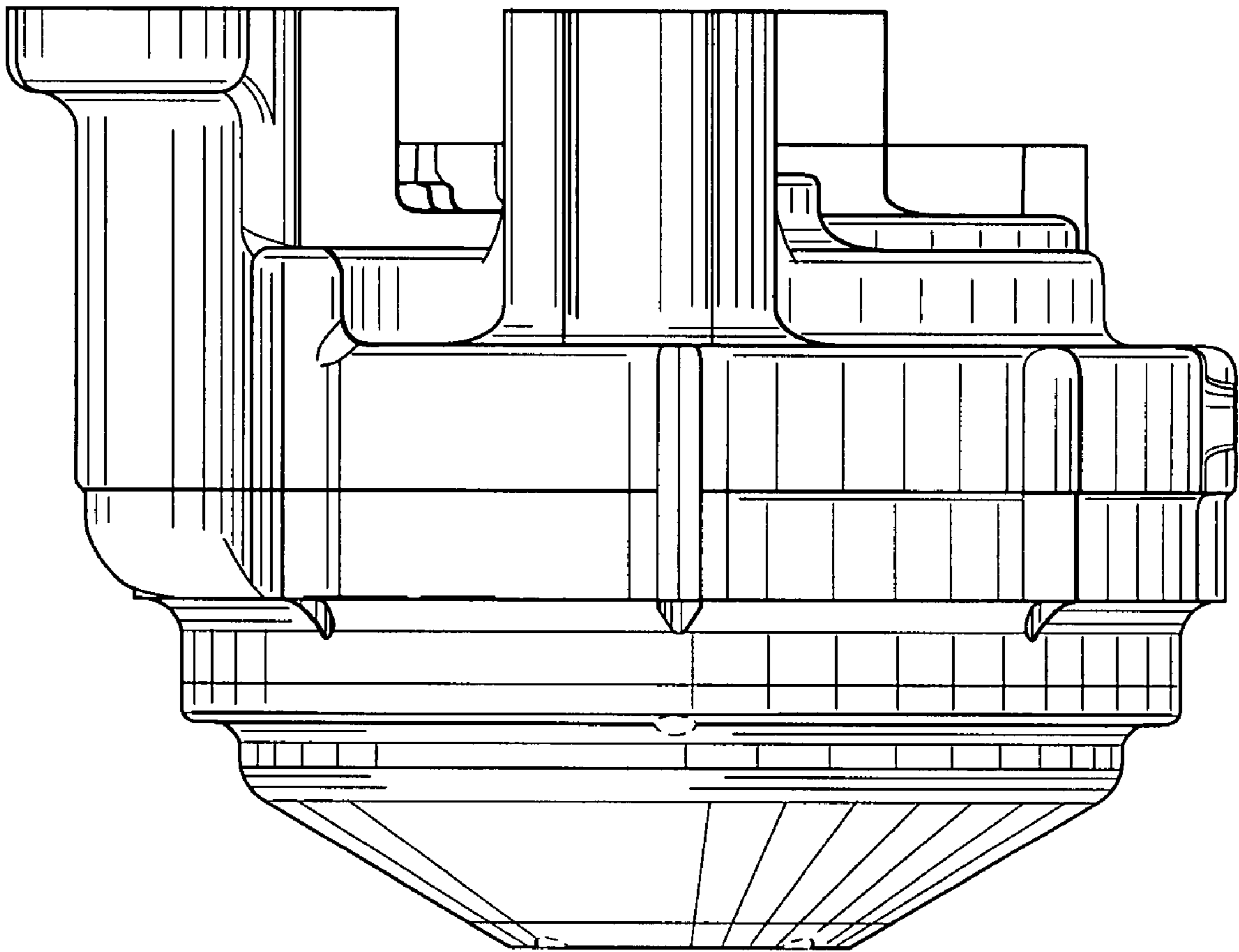

Fig. 6

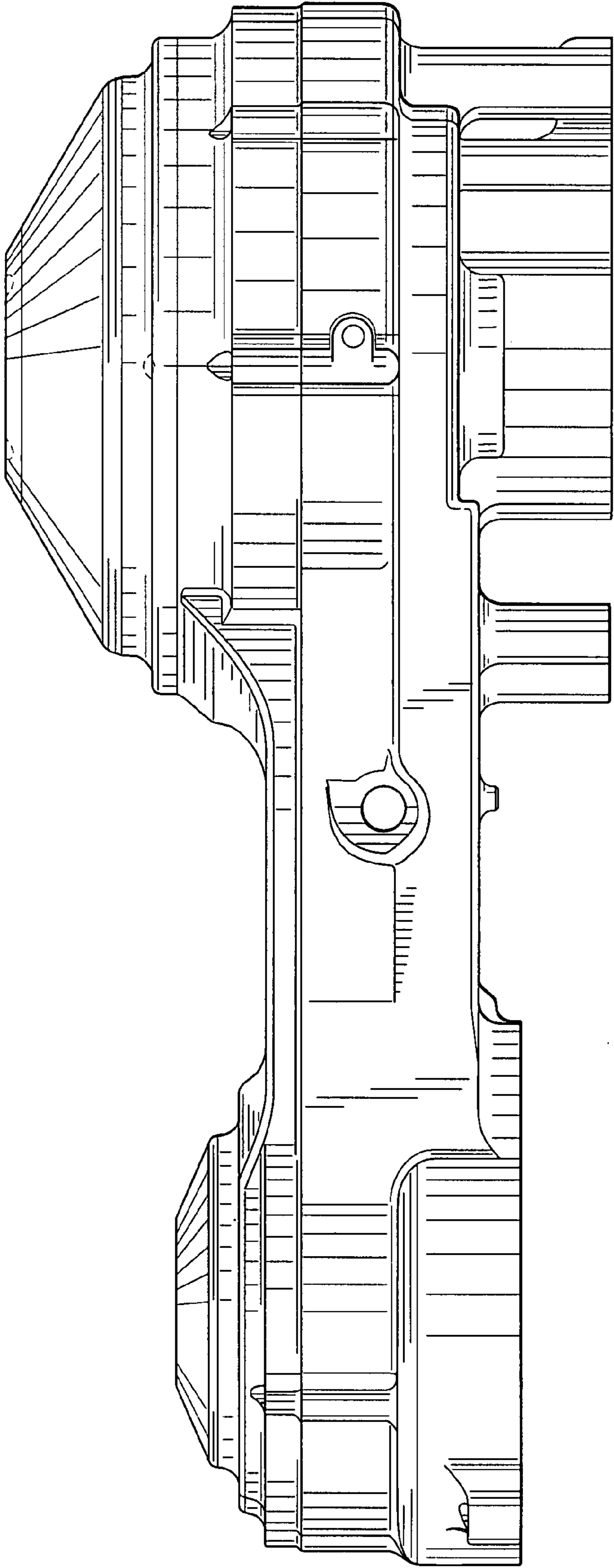

Fig. 7

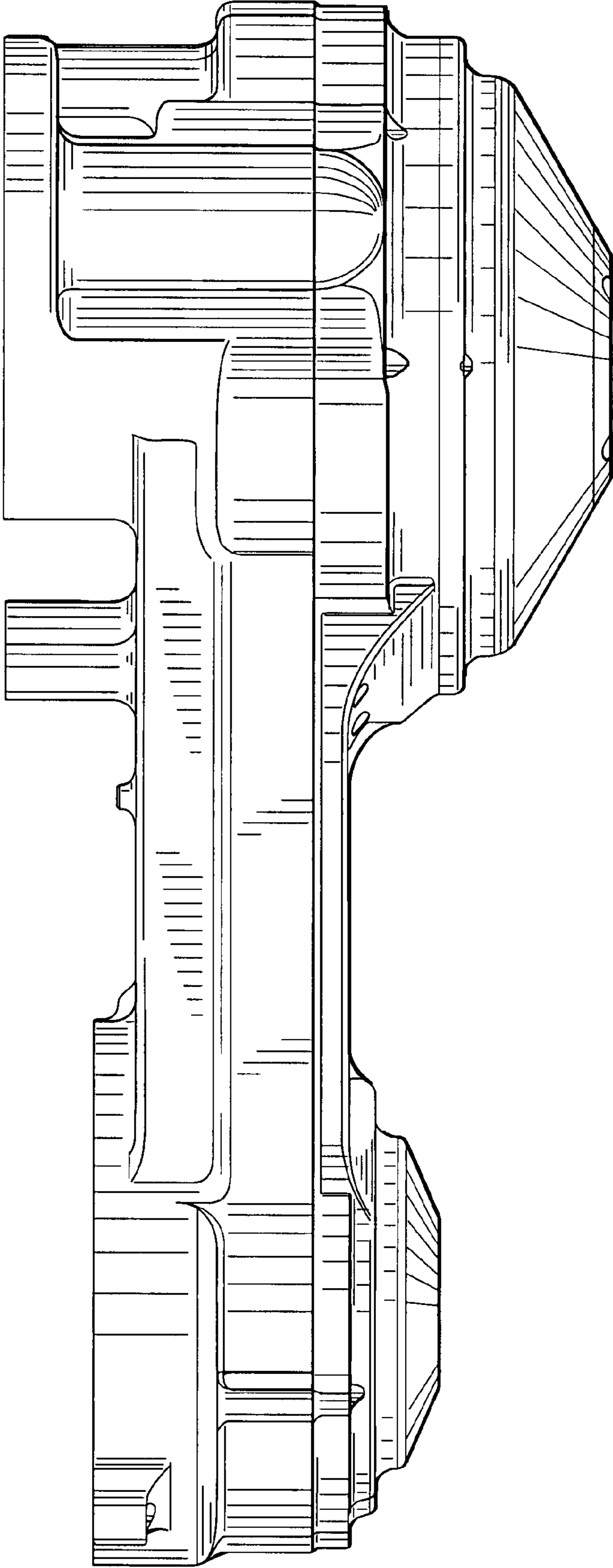



Fig. 8

