



US00D554485S

(12) **United States Design Patent**
Dubon

(10) **Patent No.:** **US D554,485 S**

(45) **Date of Patent:** **** Nov. 6, 2007**

(54) **HEAVY DUTY TELESCOPING SLIDE
HARDWARE**

(75) Inventor: **William Dubon**, Bloomingdale, IL (US)

(73) Assignee: **Pentair Electronic Packaging Co.**, Des
Plaines, IL (US)

(**) Term: **14 Years**

(21) Appl. No.: **29/244,692**

(22) Filed: **Dec. 13, 2005**

(51) **LOC (8) Cl.** **08-05**

(52) **U.S. Cl.** **D8/374**

(58) **Field of Classification Search** D8/374,
D8/499; 312/323, 333, 334.39; 211/26
See application file for complete search history.

(56) **References Cited**

U.S. PATENT DOCUMENTS

5,316,389	A *	5/1994	Hoffman	384/18
5,695,265	A *	12/1997	Hoffman	312/334.5
6,033,047	A *	3/2000	Hoffman	312/334.44

(Continued)

Primary Examiner—Holly H. Baynham

(74) *Attorney, Agent, or Firm*—Greenberg Traurig, LLP

(57) **CLAIM**

The ornamental design for a heavy duty telescoping slide hardware, as shown.

DESCRIPTION

FIG. 1 is a perspective view of a heavy duty telescoping slide hardware showing the new design;

FIG. 2 is a front elevational view;

FIG. 3 is a rear elevational view;

FIG. 4 is a right side elevational view;

FIG. 5 is a left side elevational view;

FIG. 6 is a top plan view;

FIG. 7 is a bottom plan view;

FIG. 8 is a perspective view of a second embodiment of the heavy duty telescoping slide hardware of FIG. 1;

FIG. 9 is a front elevational view of the second embodiment;

FIG. 10 is a rear elevational view of the second embodiment;

FIG. 11 is a right side elevational view of the second embodiment;

FIG. 12 is a left side elevational view of the second embodiment;

FIG. 13 is a top plan view of the second embodiment;

FIG. 14 is a bottom plan view of the second embodiment; and

FIG. 15 is a perspective view of a third embodiment of the heavy duty telescoping slide hardware of FIG. 1;

FIG. 16 is a front elevation view of the third embodiment;

FIG. 17 is a rear elevation view of the third embodiment;

FIG. 18 is a right side elevation view of the third embodiment;

FIG. 19 is a left side elevation view of the third embodiment;

FIG. 20 is a top plan view of the third embodiment; and,

FIG. 21 is a bottom plan view of the third embodiment.

The broken line showing is for illustrative purposes only and forms no part of the claimed design.

1 Claim, 8 Drawing Sheets

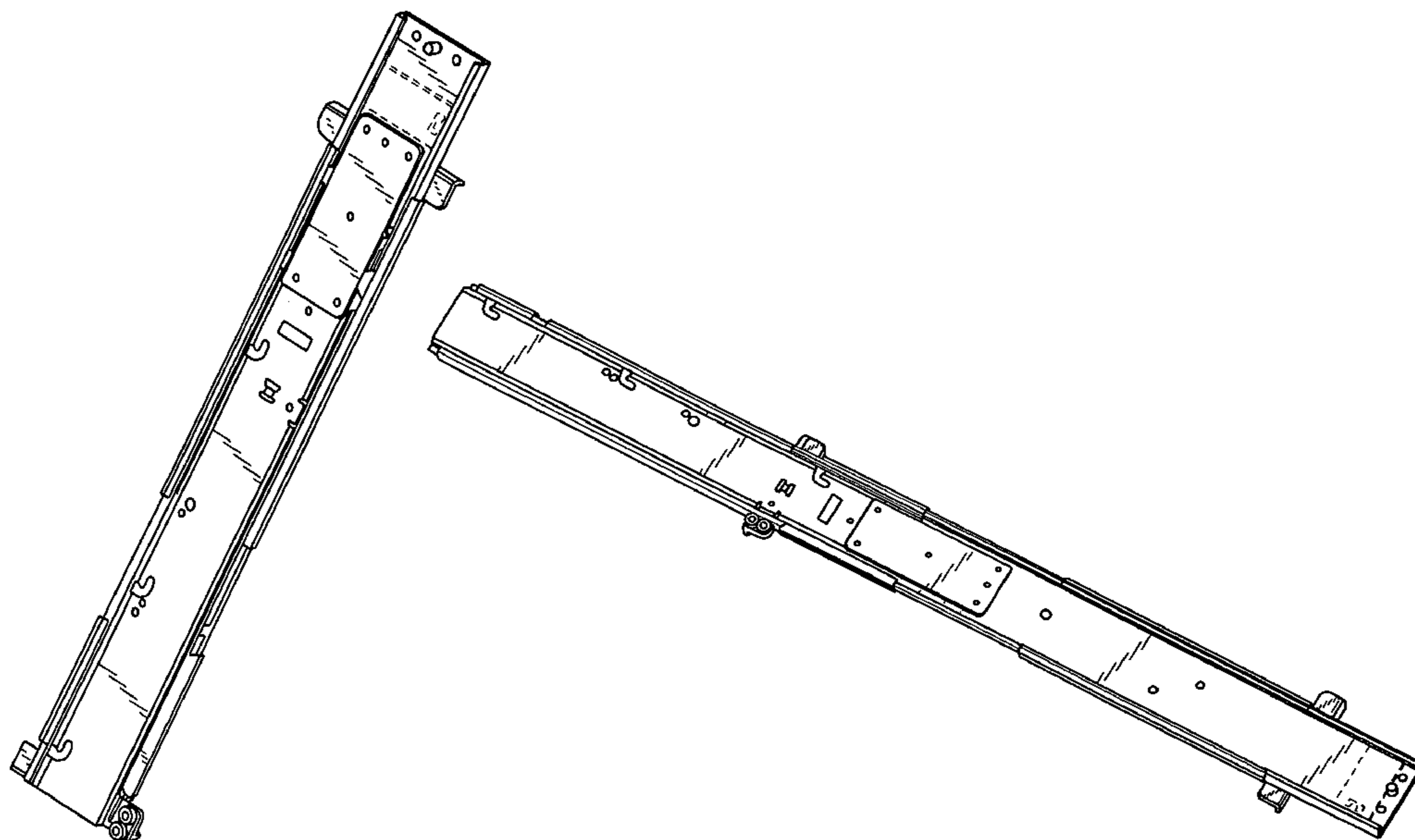

US D554,485 S

Page 2

U.S. PATENT DOCUMENTS

6,254,210	B1 *	7/2001	Parvin	312/334.46	6,860,574	B2 *	3/2005	Hwang et al.	312/334.44
6,416,145	B1 *	7/2002	Singh	312/334.1	6,926,377	B2 *	8/2005	Lammens et al.	312/333
6,685,288	B1 *	2/2004	MacMillan	312/334.46	6,935,710	B2 *	8/2005	Chen et al.	312/333
6,749,277	B2 *	6/2004	Michaels	312/334.5	6,962,397	B2 *	11/2005	Dobler et al.	312/333

* cited by examiner

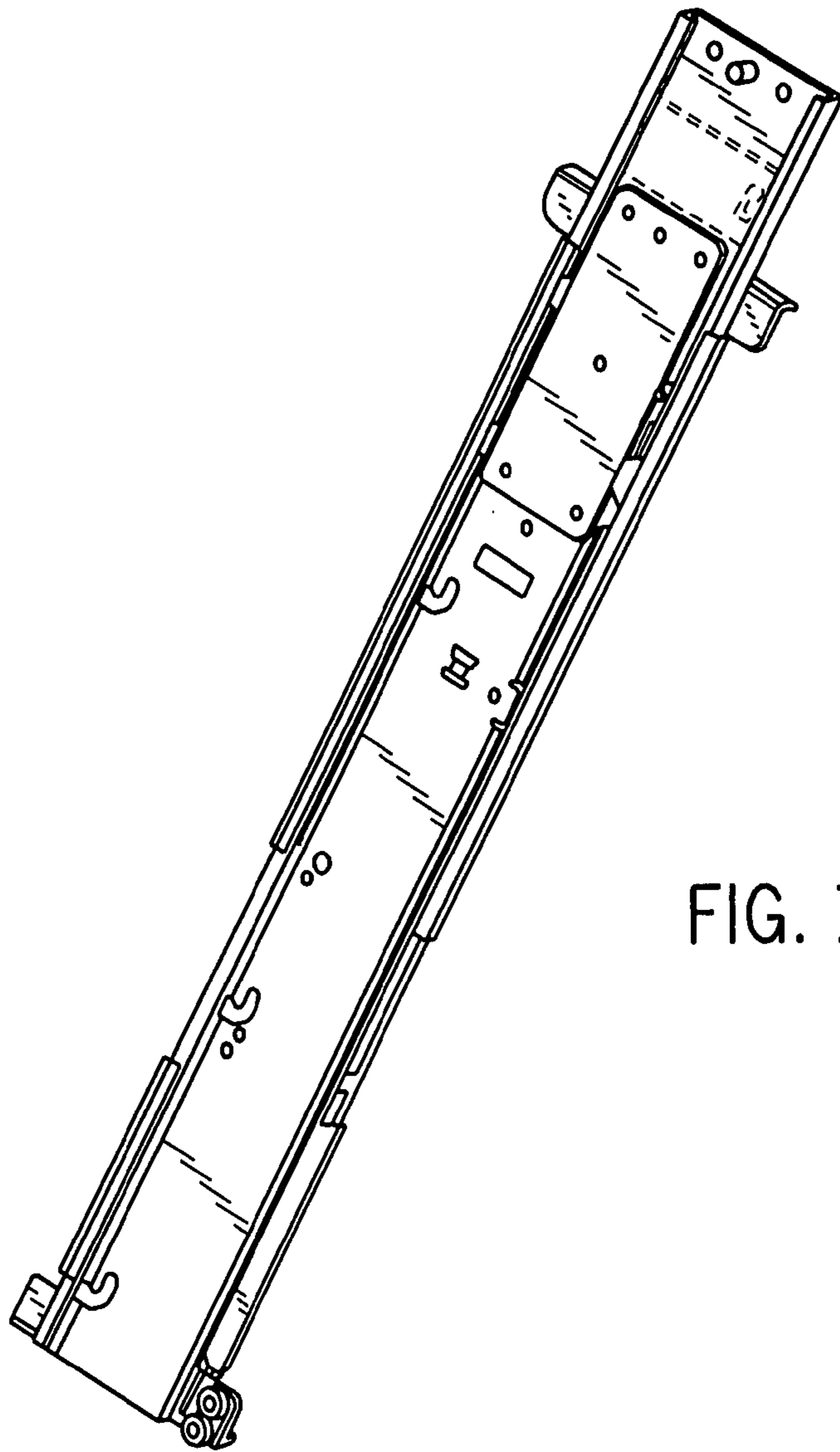

FIG. 1

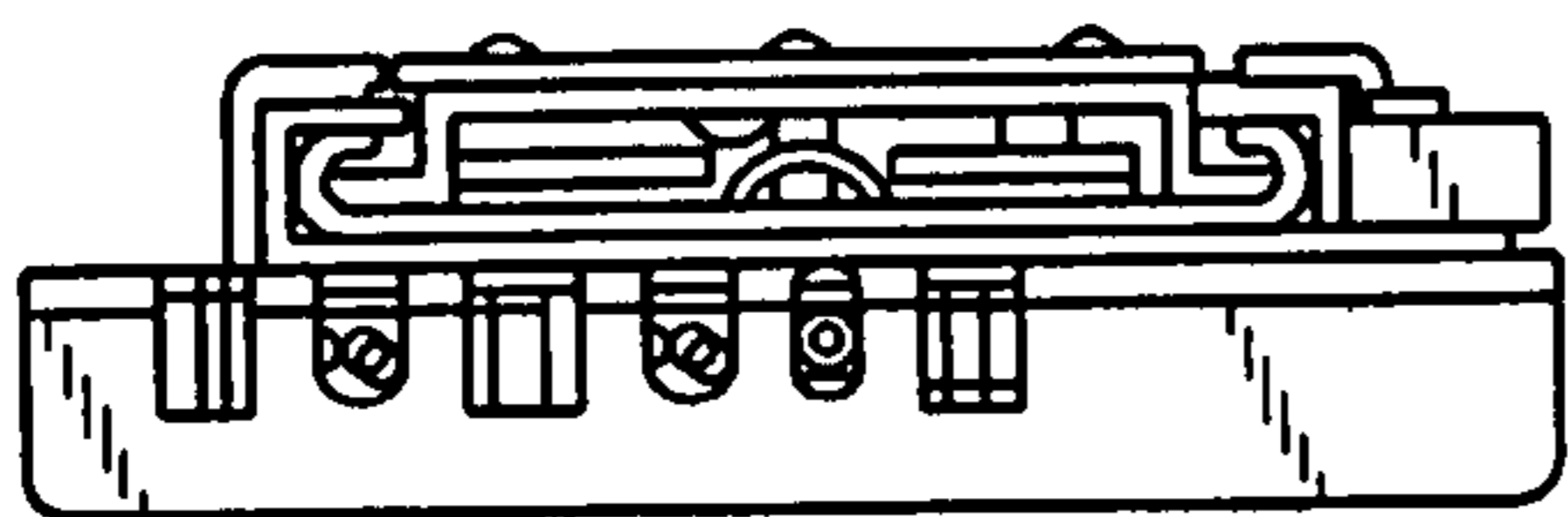

FIG. 2

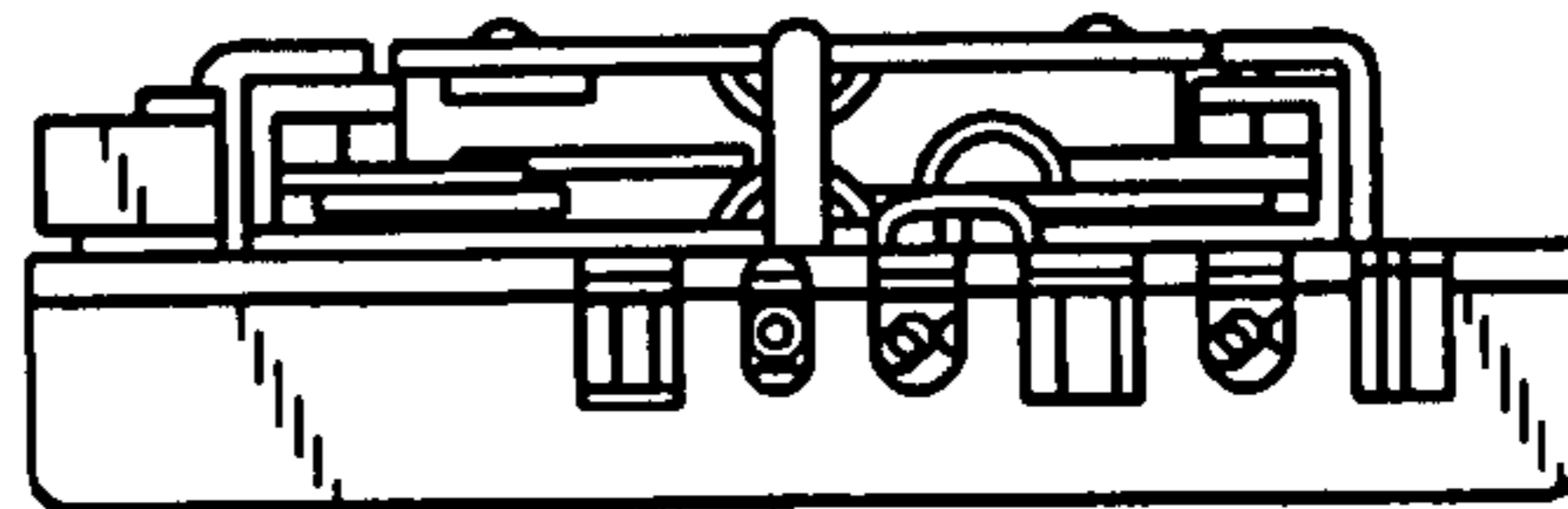

FIG. 3

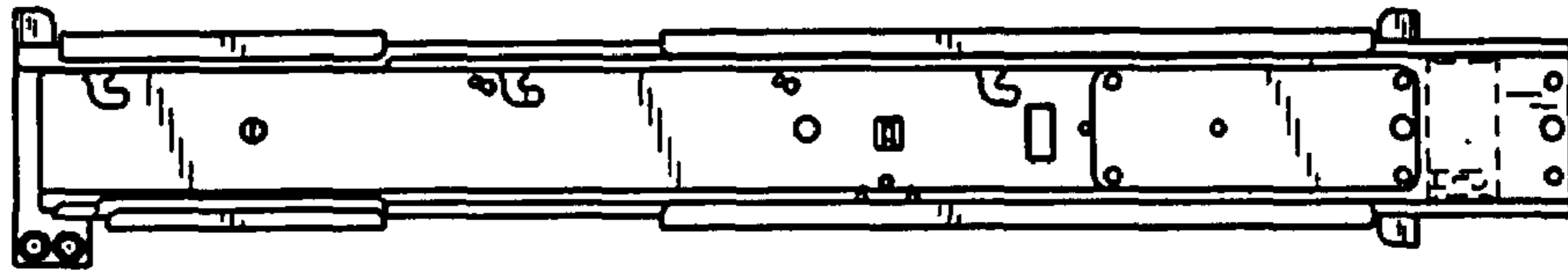

FIG. 4

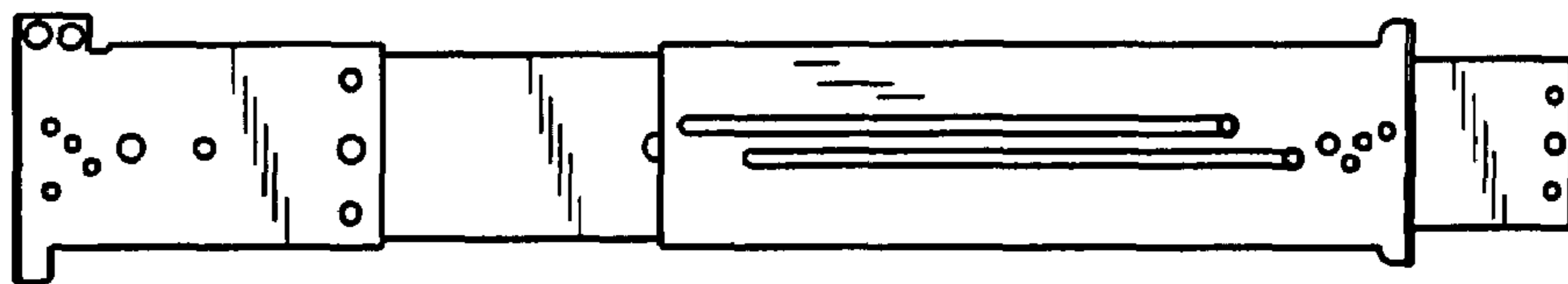

FIG. 5

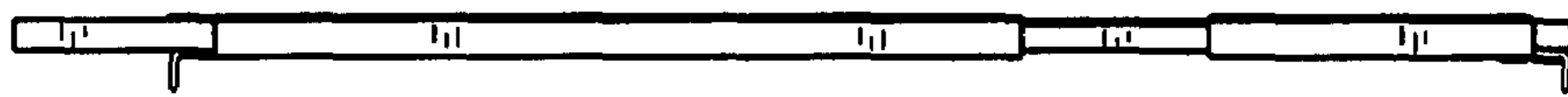

FIG. 6

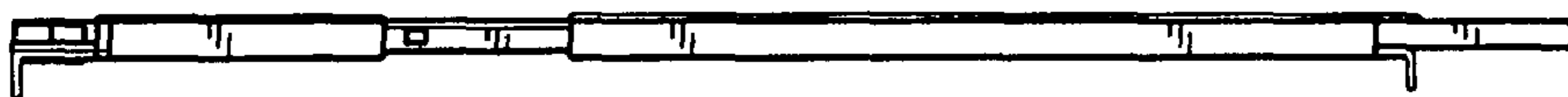

FIG. 7

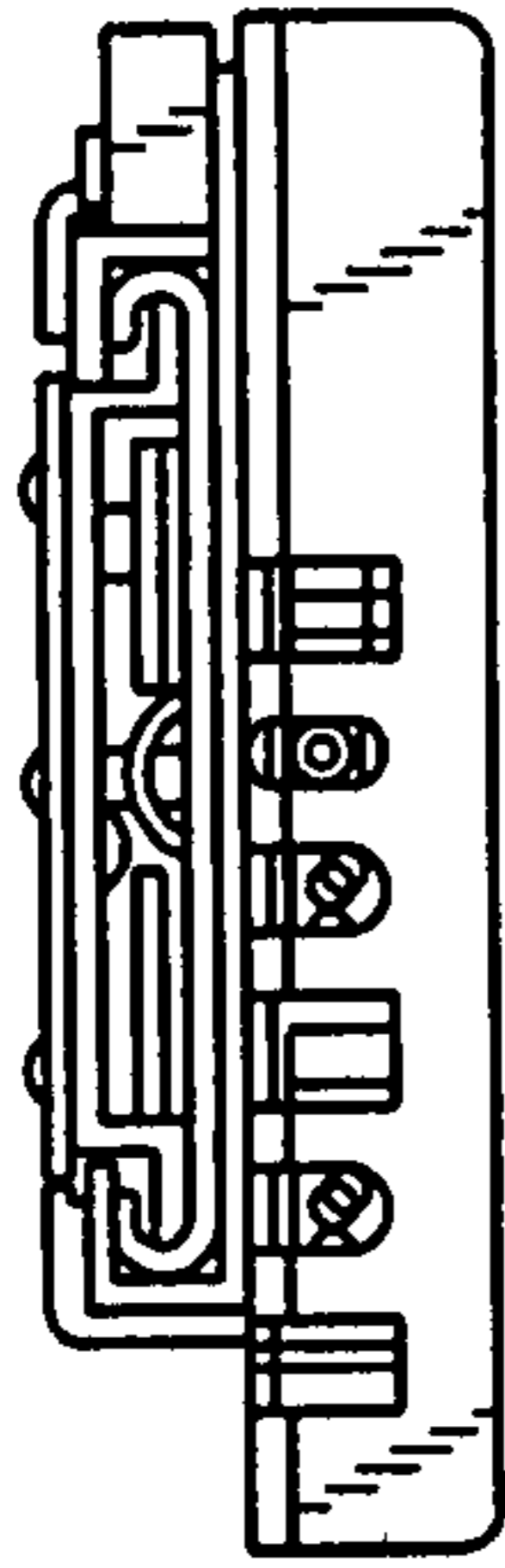

FIG. 9

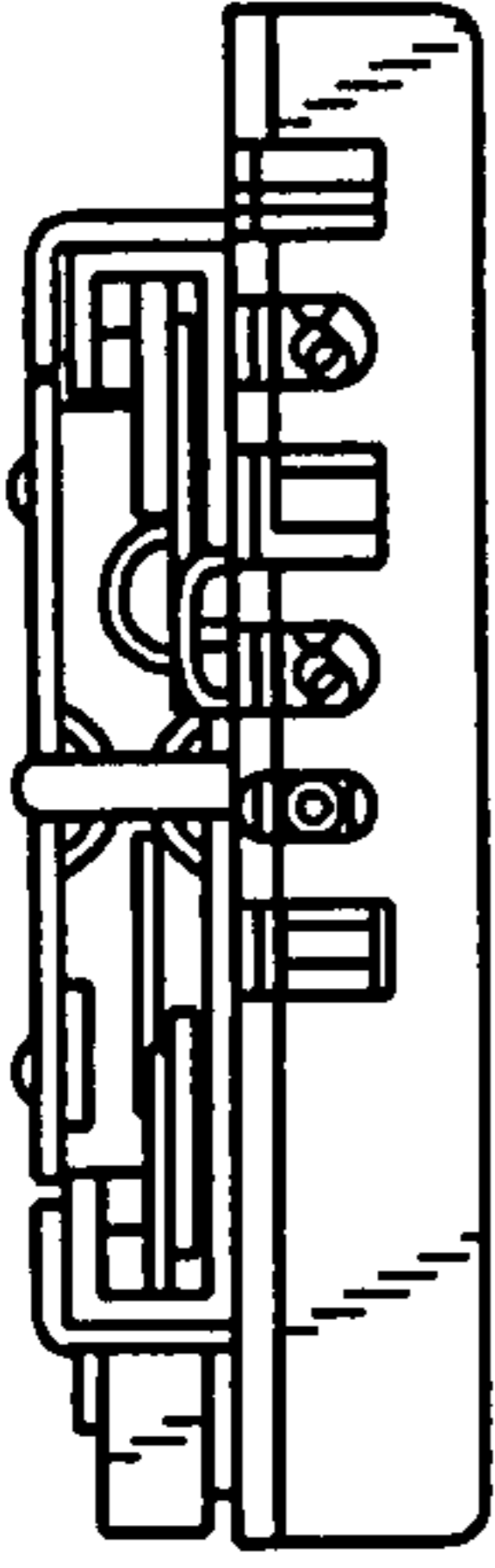

FIG. 10

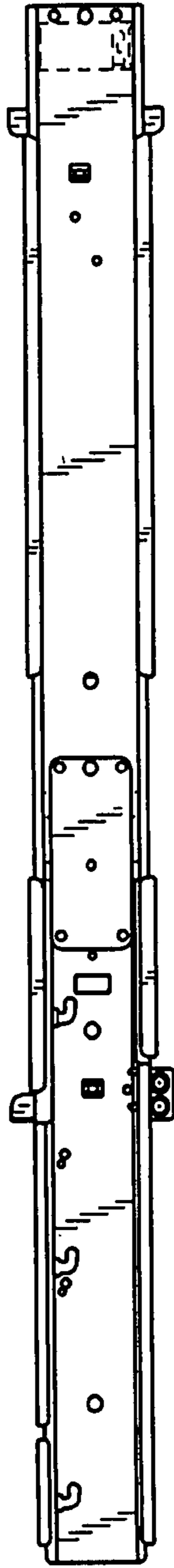

FIG. 11

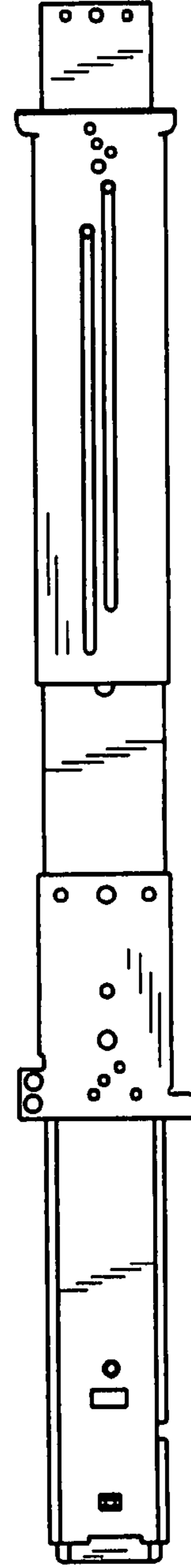

FIG. 12



FIG. 13

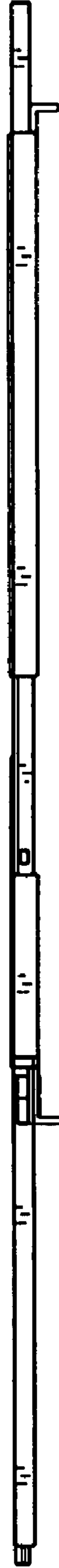

FIG. 14

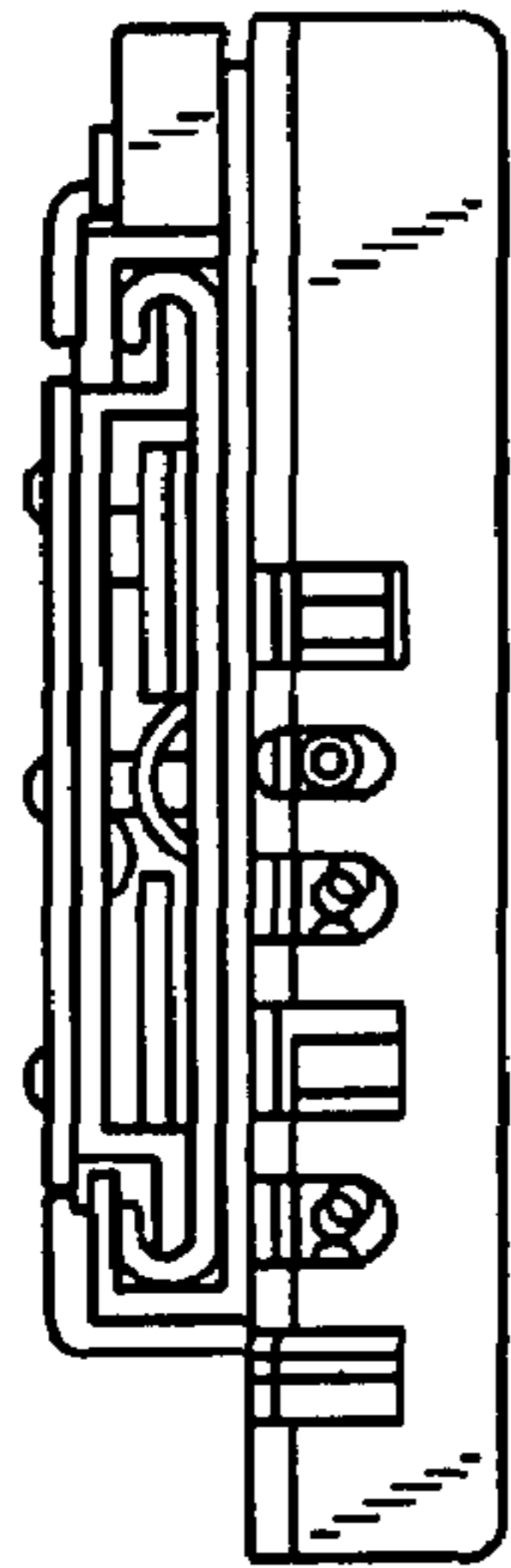

FIG. 16

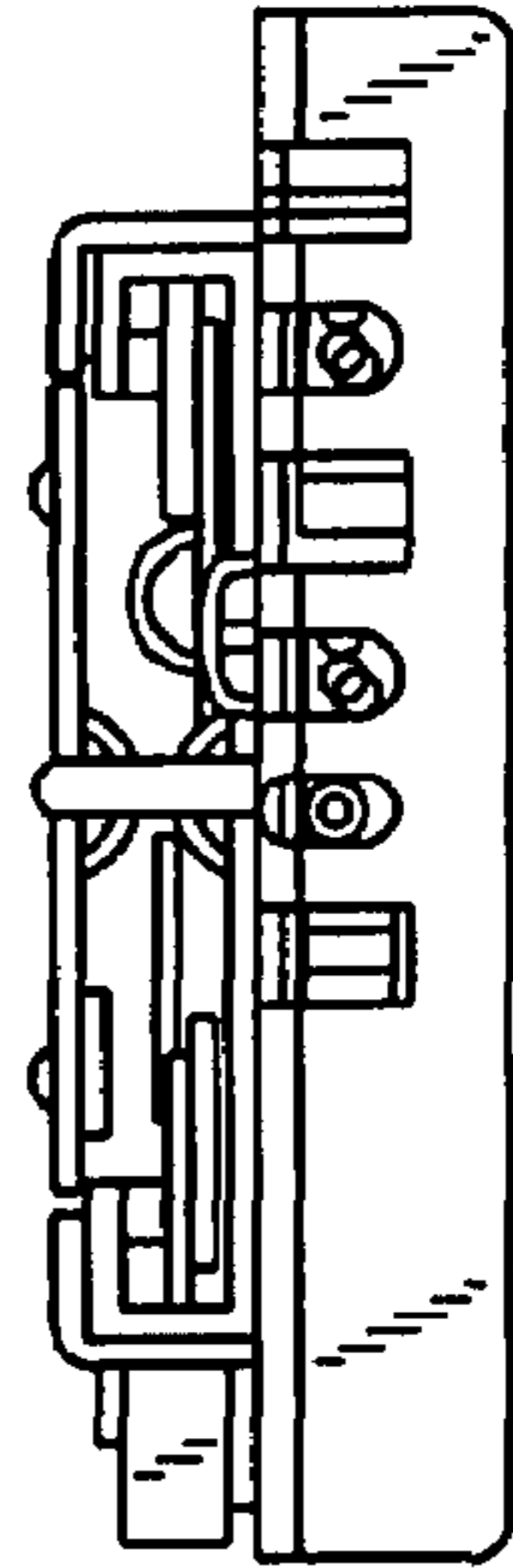

FIG. 17

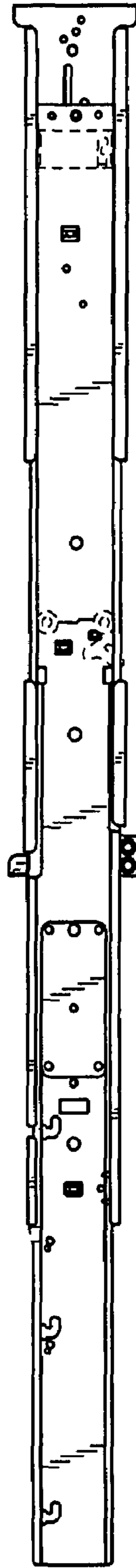

FIG. 18

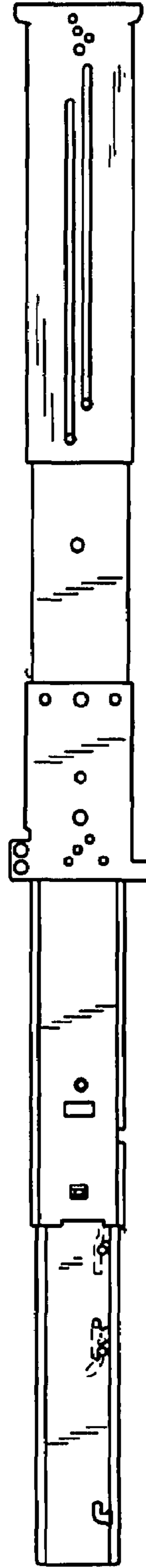

FIG. 19



FIG. 20

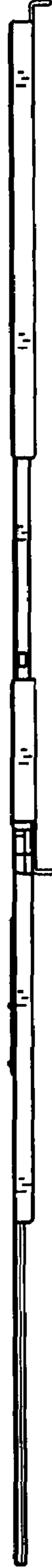

FIG. 21