



US00D554075S

(12) **United States Design Patent**  
**Tissot et al.**

(10) **Patent No.:** **US D554,075 S**

(45) **Date of Patent:** **\*\* Oct. 30, 2007**

(54) **TACTIL CONTROL OF WINDOW-LIFTS AND LATERAL REAR VIEW MIRRORS FOR AN AUTOMOTIVE VEHICLE**

(75) Inventors: **Jean Marc Tissot**, Viuz en Sallaz (FR);  
**Sheng Wang**, Ville-la-Grand (FR)

(73) Assignee: **DAV**, Creteil (FR)

(\*\*) Term: **14 Years**

(21) Appl. No.: **29/268,473**

(22) Filed: **Nov. 6, 2006**

(30) **Foreign Application Priority Data**

May 12, 2006 (EM) ..... 000527429-0001

(51) **LOC (8) Cl.** ..... **13-03**

(52) **U.S. Cl.** ..... **D13/164**

(58) **Field of Classification Search** ..... D13/168,  
D13/164, 162; D12/192-195; D14/388;  
D8/302, 315; 200/1 R, 5 R, 52 R, 315, 310,  
200/6 A, 302.1, 308, 314, 317; 296/153;  
297/411.21; 307/10.1; 362/501, 23, 276,  
362/29, 464, 802, 85

See application file for complete search history.

(56) **References Cited**

**U.S. PATENT DOCUMENTS**

D186,944 S \* 12/1959 Everett ..... D13/174  
D266,083 S \* 9/1982 Klaus ..... D13/164  
D266,415 S \* 10/1982 Cremer ..... D13/164  
4,463,234 A \* 7/1984 Bennowitz ..... 200/516  
D276,151 S \* 10/1984 Vitaloni ..... D13/171  
4,751,351 A \* 6/1988 Lambke ..... 200/409

D343,165 S \* 1/1994 Byar ..... D13/164  
5,550,339 A \* 8/1996 Haugh ..... 200/5 A  
D410,008 S \* 5/1999 Almqvist ..... D14/223  
D448,270 S \* 9/2001 Sekishiro et al. .... D8/302  
D457,862 S \* 5/2002 Falk et al. .... D13/162  
6,528,742 B2 \* 3/2003 Serizawa et al. .... 200/5 R  
6,608,399 B2 \* 8/2003 McConnell et al. .... 307/10.1  
6,646,217 B2 \* 11/2003 Omata ..... 200/406  
6,657,316 B1 \* 12/2003 Smith et al. .... 307/10.1  
D520,962 S \* 5/2006 Seal et al. .... D13/164  
D526,973 S \* 8/2006 Gates et al. .... D13/184  
D533,516 S \* 12/2006 Murata et al. .... D13/168  
7,215,321 B2 \* 5/2007 SanGiovanni ..... 345/156  
2003/0052514 A1 \* 3/2003 Schmidt et al. .... 296/153  
2003/0226745 A1 \* 12/2003 Sato et al. .... 200/5 R  
2005/0134116 A1 \* 6/2005 Hein et al. .... 307/10.1  
2006/0092038 A1 \* 5/2006 Unger ..... 340/825.25  
2007/0095633 A1 \* 5/2007 Sakai ..... 200/1 R

\* cited by examiner

*Primary Examiner*—Selina Sikder

*Assistant Examiner*—Thomas J Johannes

(74) *Attorney, Agent, or Firm*—Osha Liang LLP

(57) **CLAIM**

The ornamental design for tactil control of window-lifts and lateral rear view mirrors for an automotive vehicle, as shown and described.

**DESCRIPTION**

FIG. 1 is a perspective view of a design for tactil control of window-lifts and lateral rear view mirrors for an automotive vehicle showing our new design; and, FIG. 2 is a front view thereof.

**1 Claim, 1 Drawing Sheet**

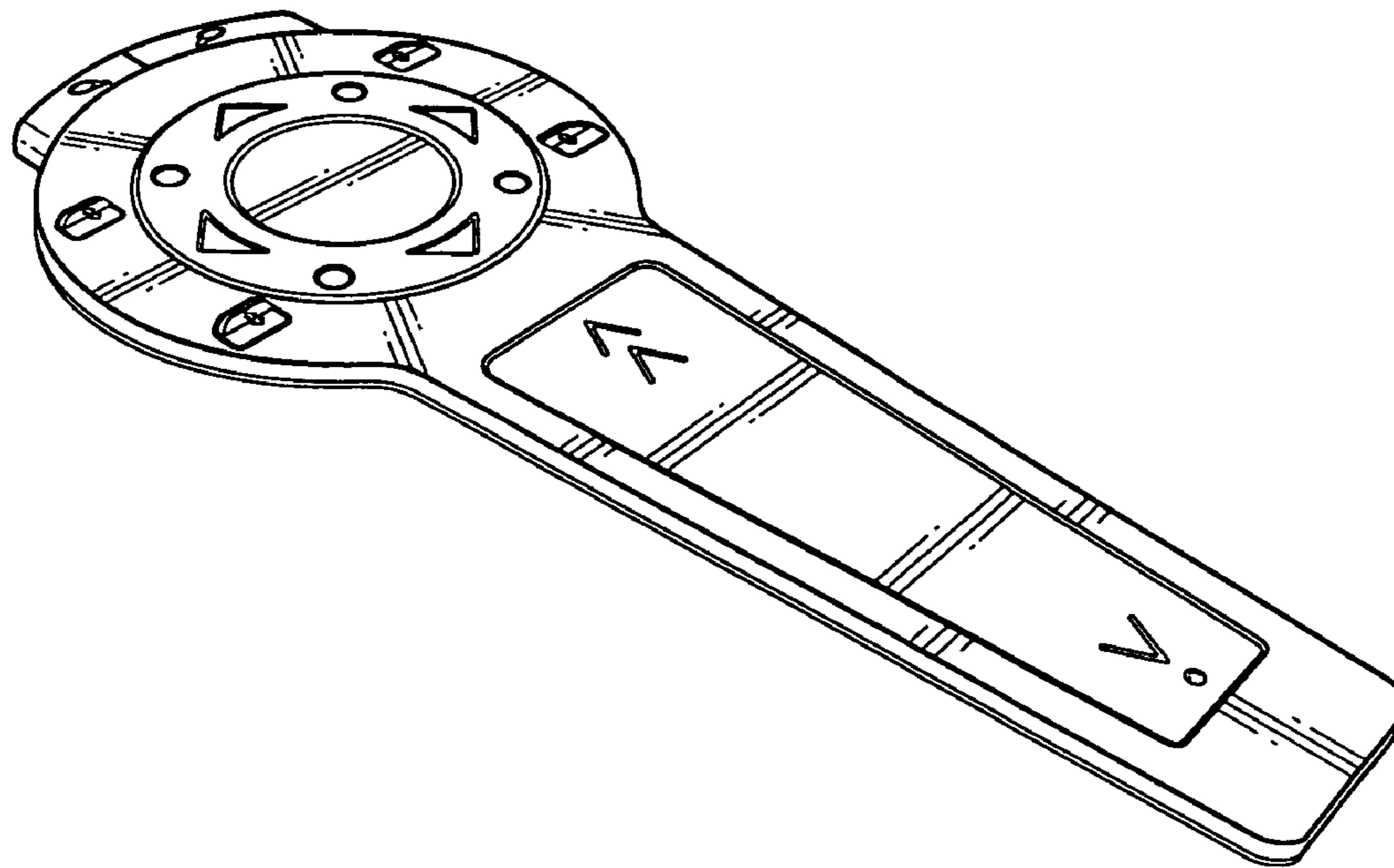

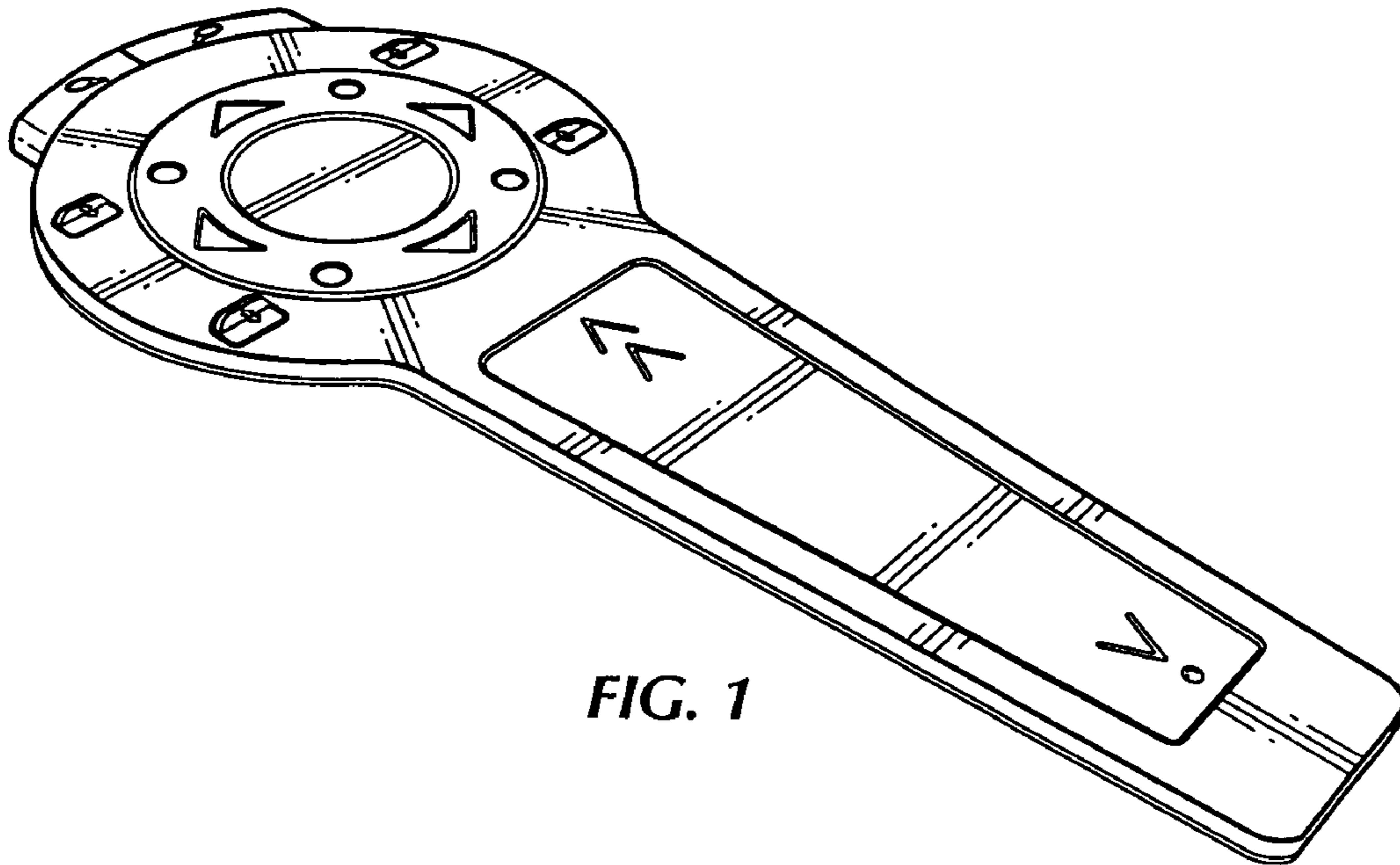

FIG. 1

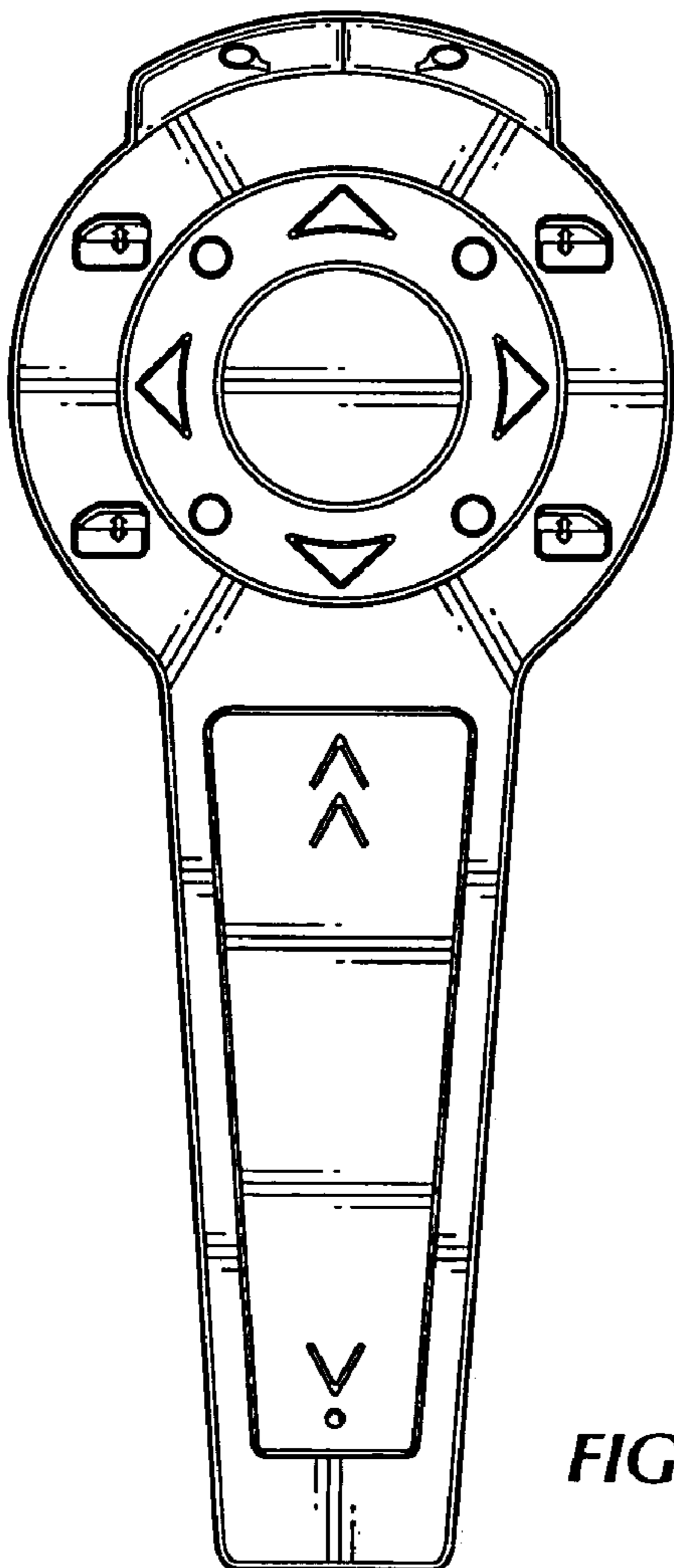

FIG. 2