



US00D553766S

(12) **United States Design Patent** (10) **Patent No.:** **US D553,766 S**  
**Golden et al.** (45) **Date of Patent:** **\*\* Oct. 23, 2007**

(54) **VEHICLE TAIL LIGHT LENS**

(75) Inventors: **Edward Golden**, Pinckney, MI (US); **Darrell Behmer**, Novi, MI (US); **Melvin Betancourt**, Shelby Township, MI (US); **Solomon Song**, Farmington Hills, MI (US); **Shawn Wehrly**, Royal Oak, MI (US); **Addam Ebel**, Dearborn, MI (US); **Sang Kim**, Canton, MI (US); **Garen Nicoghosian**, Beverly Hills, MI (US)

(73) Assignee: **Ford Global Technologies, LLC**, Dearborn, MI (US)

(\*\*) Term: **14 Years**

(21) Appl. No.: **29/241,541**

(22) Filed: **Oct. 27, 2005**

(51) **LOC (8) Cl.** ..... **26-06**

(52) **U.S. Cl.** ..... **D26/28**

(58) **Field of Classification Search** ..... D26/28-36;  
362/459-468, 475-478, 485-487  
See application file for complete search history.

(56) **References Cited**

**U.S. PATENT DOCUMENTS**

D494,294 S	*	8/2004	Pfeiffer	.....	D26/28
D502,561 S	*	3/2005	Metros et al.	.....	D26/28
D508,746 S	*	8/2005	Lai	.....	D26/28
D523,976 S	*	6/2006	Pfeiffer et al.	.....	D26/28

**OTHER PUBLICATIONS**

AutoWeek.com, *2007 Edge*, Jul. 6, 2005 <http://forums.autoweek.com/thread.jspa?forumID=2358&threadID=17785&messageID=388305>.

TheCarConnection.com, TCC Message Boards—*Concepts, Spy Shots and Future Cars—2007 Ford Edge*, Aug. 11, 2005 <http://forum.thecarconnection.com/showthread.php?t=2418>.

Chicago Tribune—Online Edition, *The 2007 Ford Edge crossover vehicle, derived from the Mazda6 sedan, will make its debut early next year.* Aug. 24, 2005 [http://www.chicagotribune.com/classified/automotive/chi-050824mateja-pix\\_1,5840997.photo?coll=chi-classifiedcars-hed](http://www.chicagotribune.com/classified/automotive/chi-050824mateja-pix_1,5840997.photo?coll=chi-classifiedcars-hed).

Popular Mechanics Online, *PM.com Exclusive: 2 Look-a-like Mules*, Sep. 8, 2005 [http://www.popularmechanics.com/automotive/spy\\_reports/1829262.html](http://www.popularmechanics.com/automotive/spy_reports/1829262.html).

Edmunds.com, *New Ford Edge Crossover Caught Testing*, Sep. 26, 2005 <http://www.edmunds.com/insideline/do/Features/articleId=107367>.

\* cited by examiner

*Primary Examiner*—Marcus A. Jackson

(74) *Attorney, Agent, or Firm*—Fredrick Owens

(57) **CLAIM**

The ornamental design for a vehicle tail light lens as shown and described in FIGS. 1-12.

**DESCRIPTION**

FIG. 1 is a frontal perspective view of a left vehicle tail light lens attached to a vehicle, no part of the vehicle is claimed; FIG. 2 is a perspective view of the left vehicle tail light lens; FIG. 3 is a front elevational view of the left vehicle tail light lens;

FIG. 4 is a left side elevational view of the left vehicle tail light lens;

FIG. 5 is a top plan view of the left vehicle tail light lens; FIG. 6 is a bottom plan view of the left vehicle tail light lens;

FIG. 7 is a frontal perspective view of an alternative embodiment of the vehicle tail light lens illustrated in FIGS. 1-6, showing a right vehicle tail light lens attached to a vehicle, no part of the vehicle is claimed;

FIG. 8 is a perspective view of the right vehicle tail light lens;

FIG. 9 is a front elevational view of the right vehicle tail light lens;

FIG. 10 is a right side elevational view of the right vehicle tail light lens;

FIG. 11 is a top plan view of the right vehicle tail light lens; and,

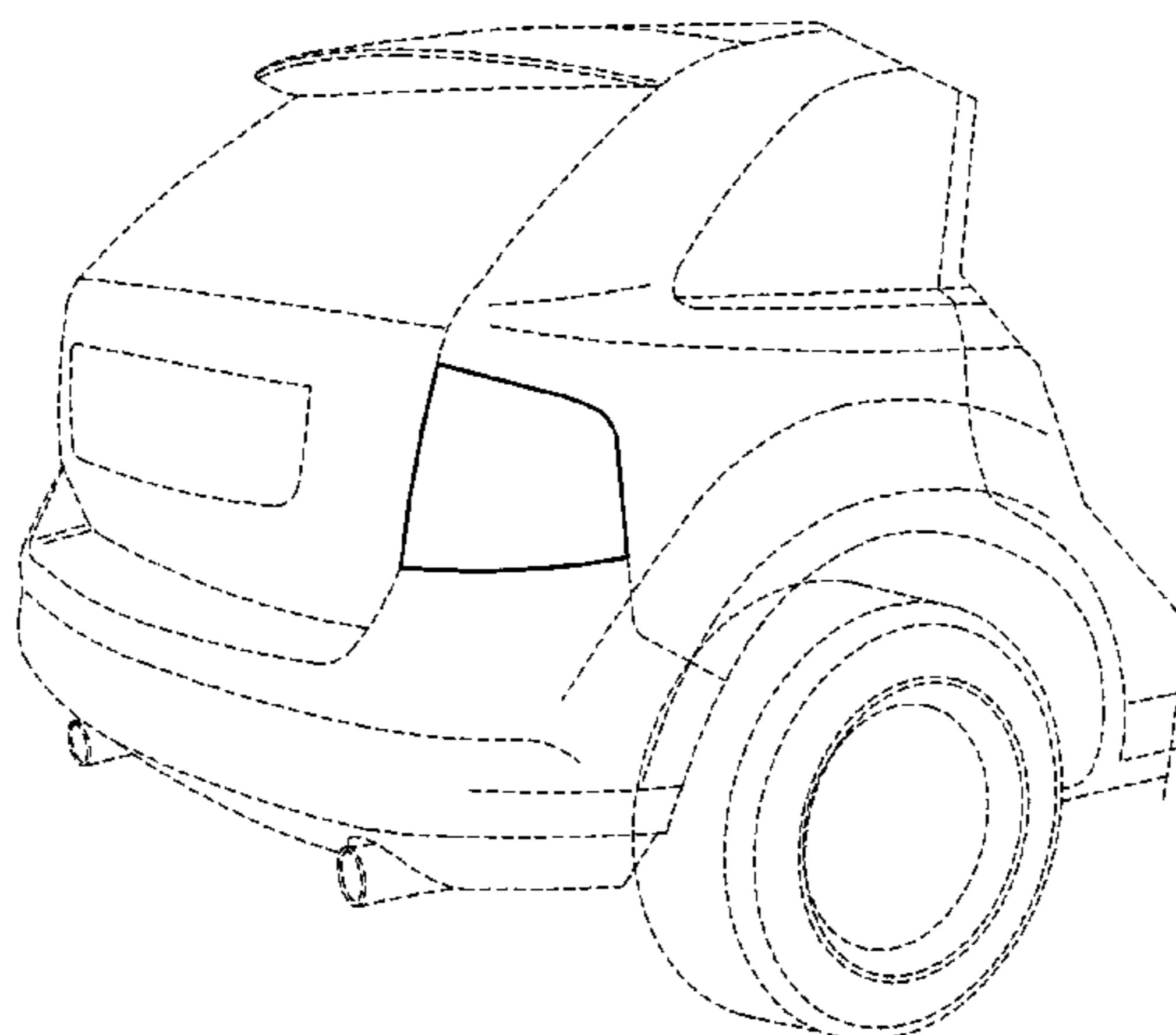
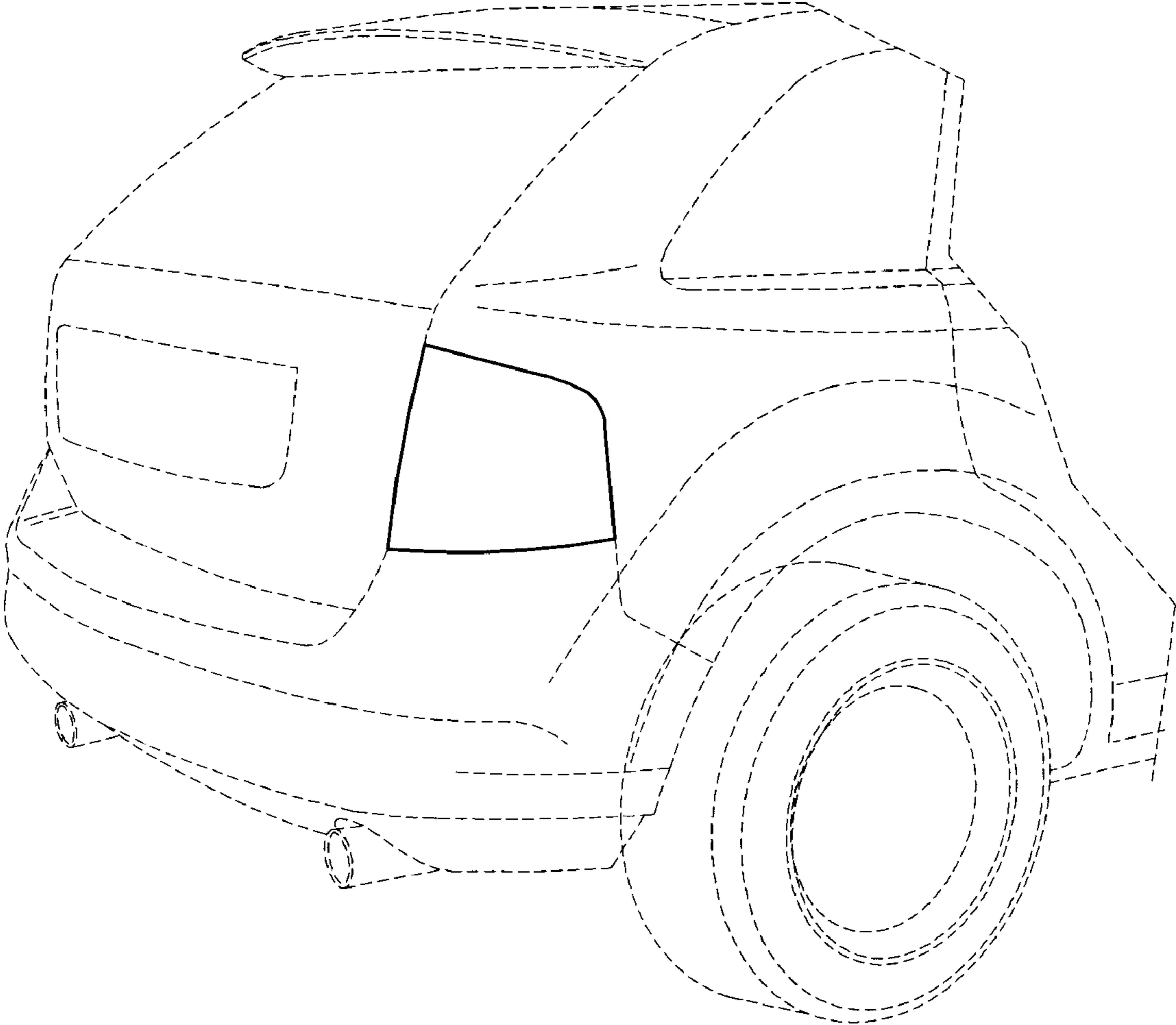


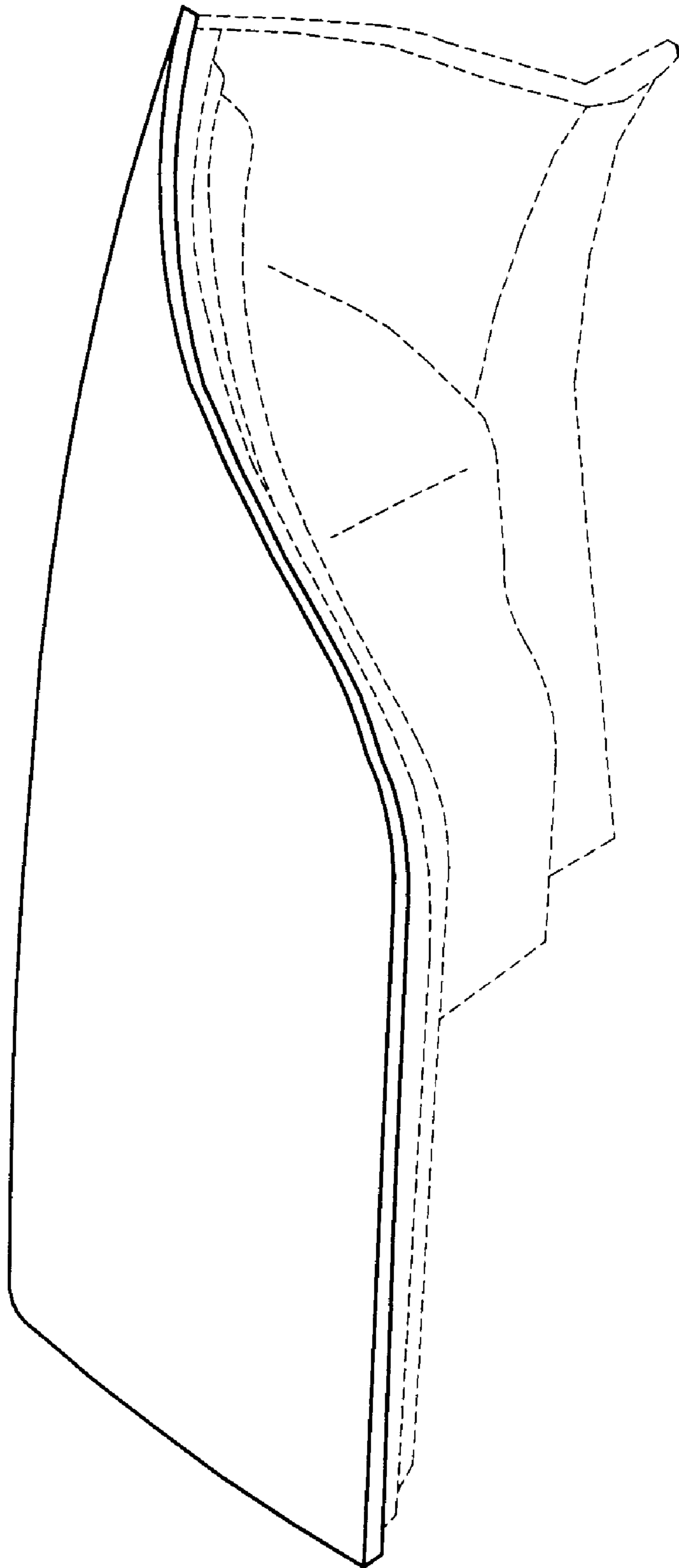
FIG. 12 is a bottom plan view of the right vehicle tail light lens.

The phantom lines are not a part of the claimed invention. The stippling indicates the curvature of the vehicle tail light lens.

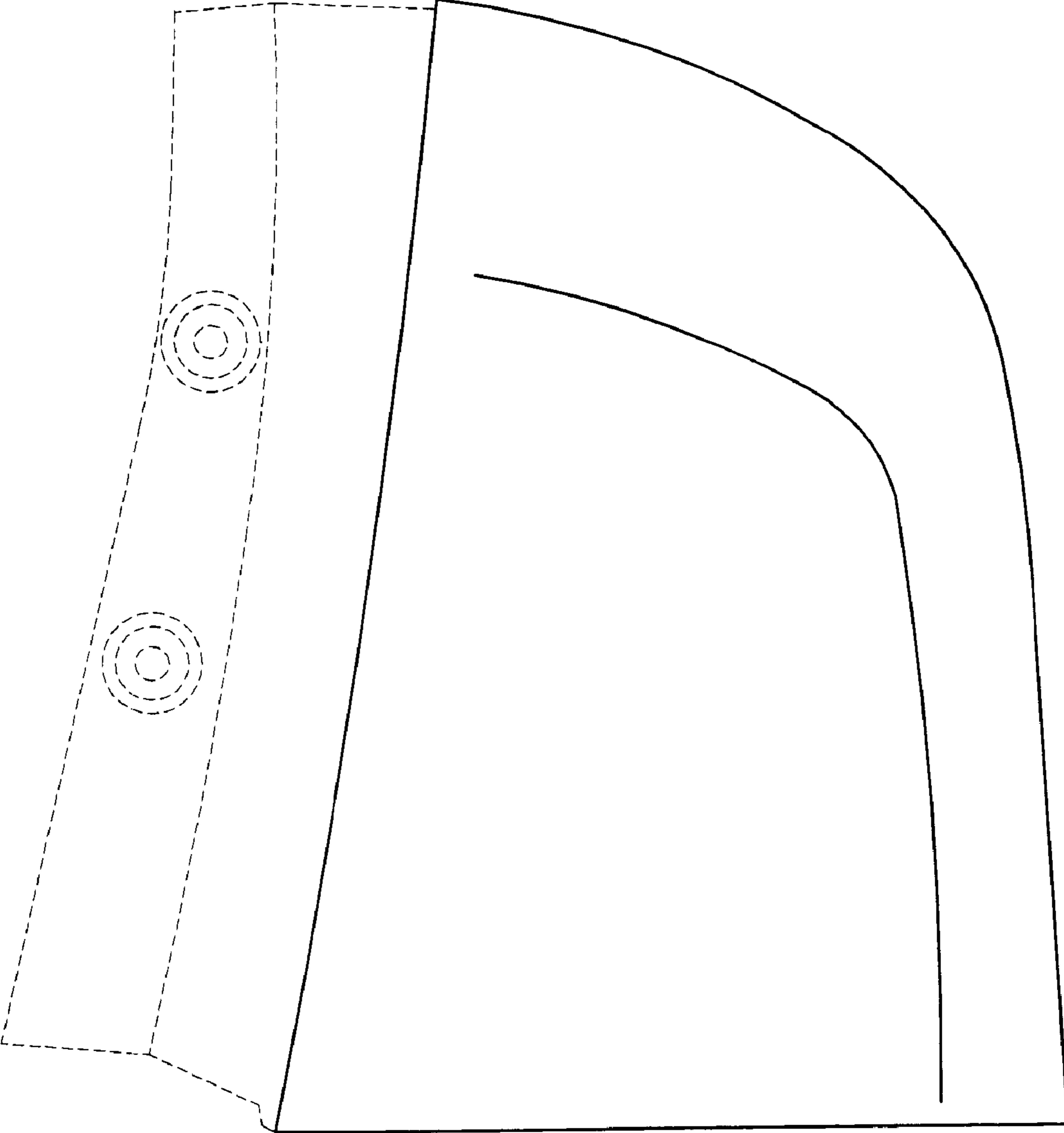
**1 Claim, 12 Drawing Sheets**



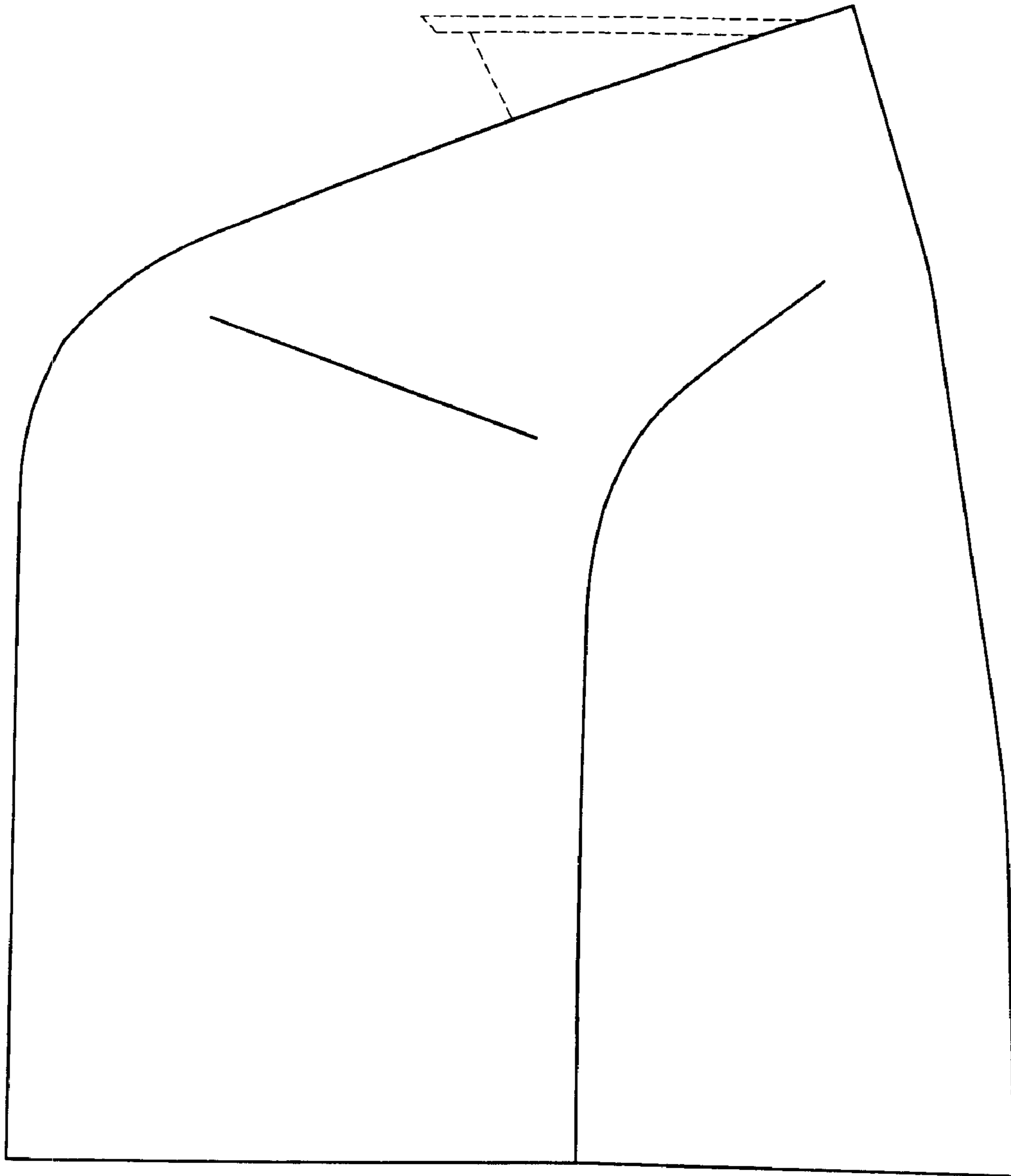
**FIG - 1**



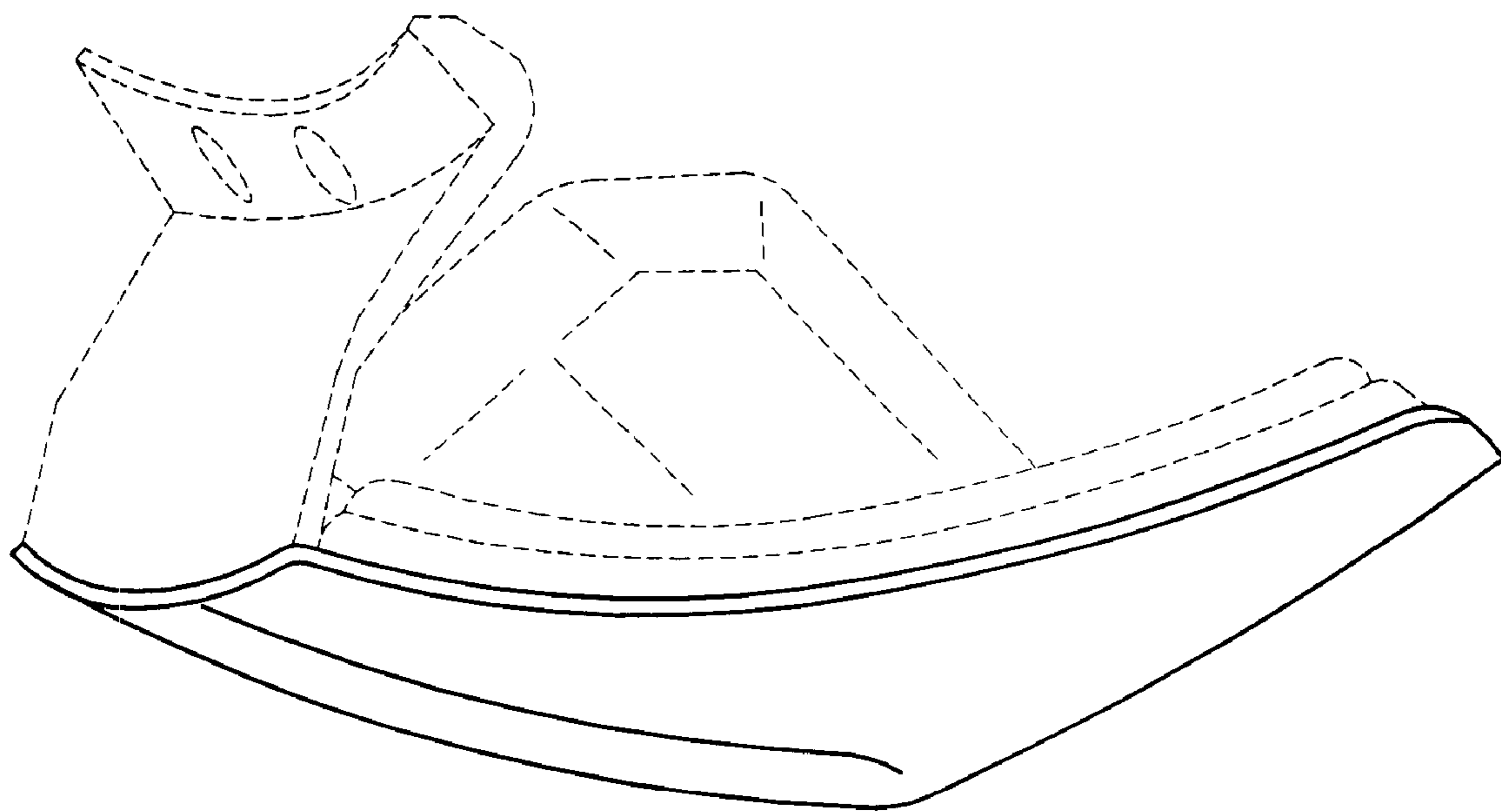
**FIG - 2**



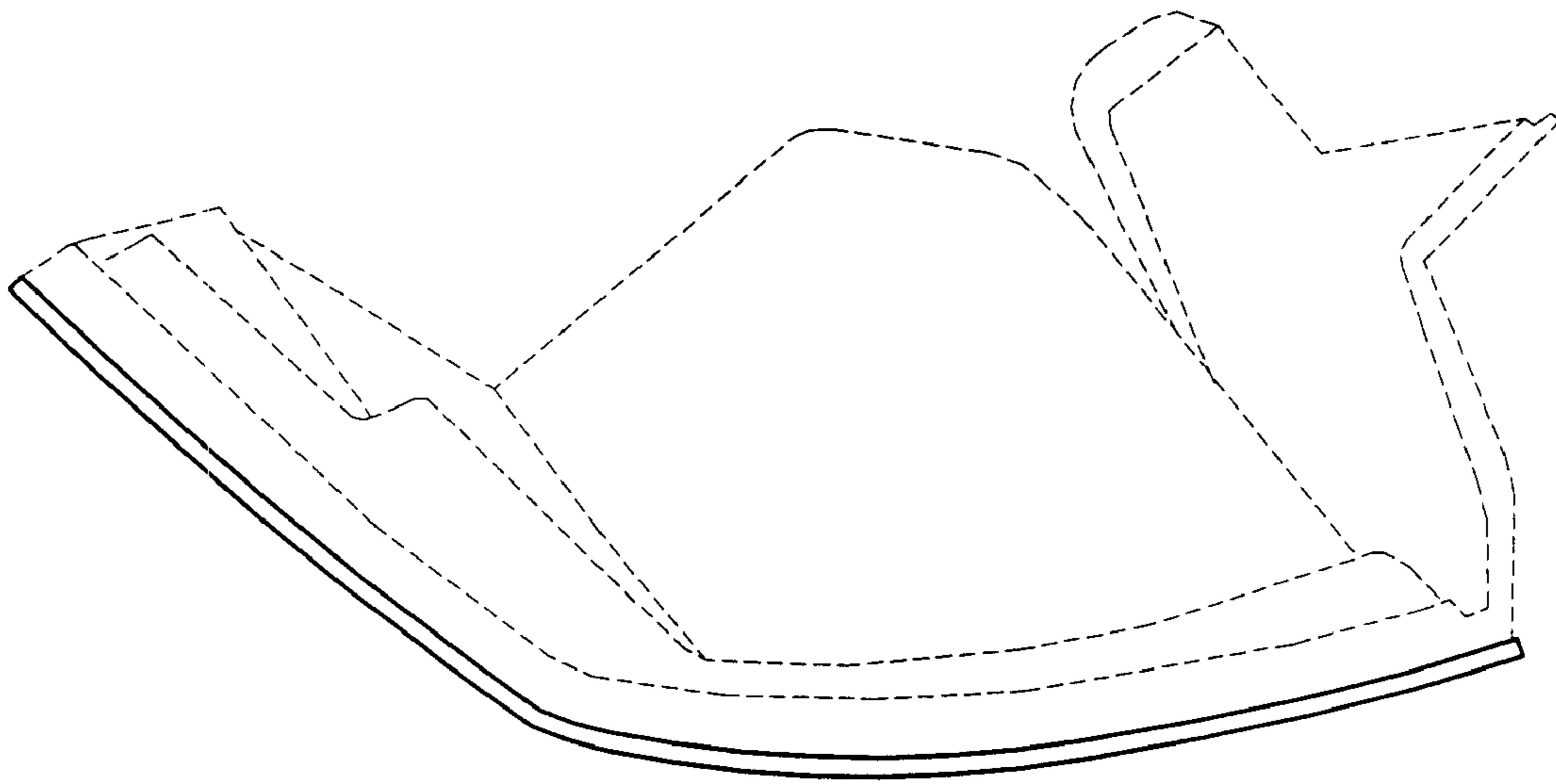
**FIG - 3**



**FIG - 4**

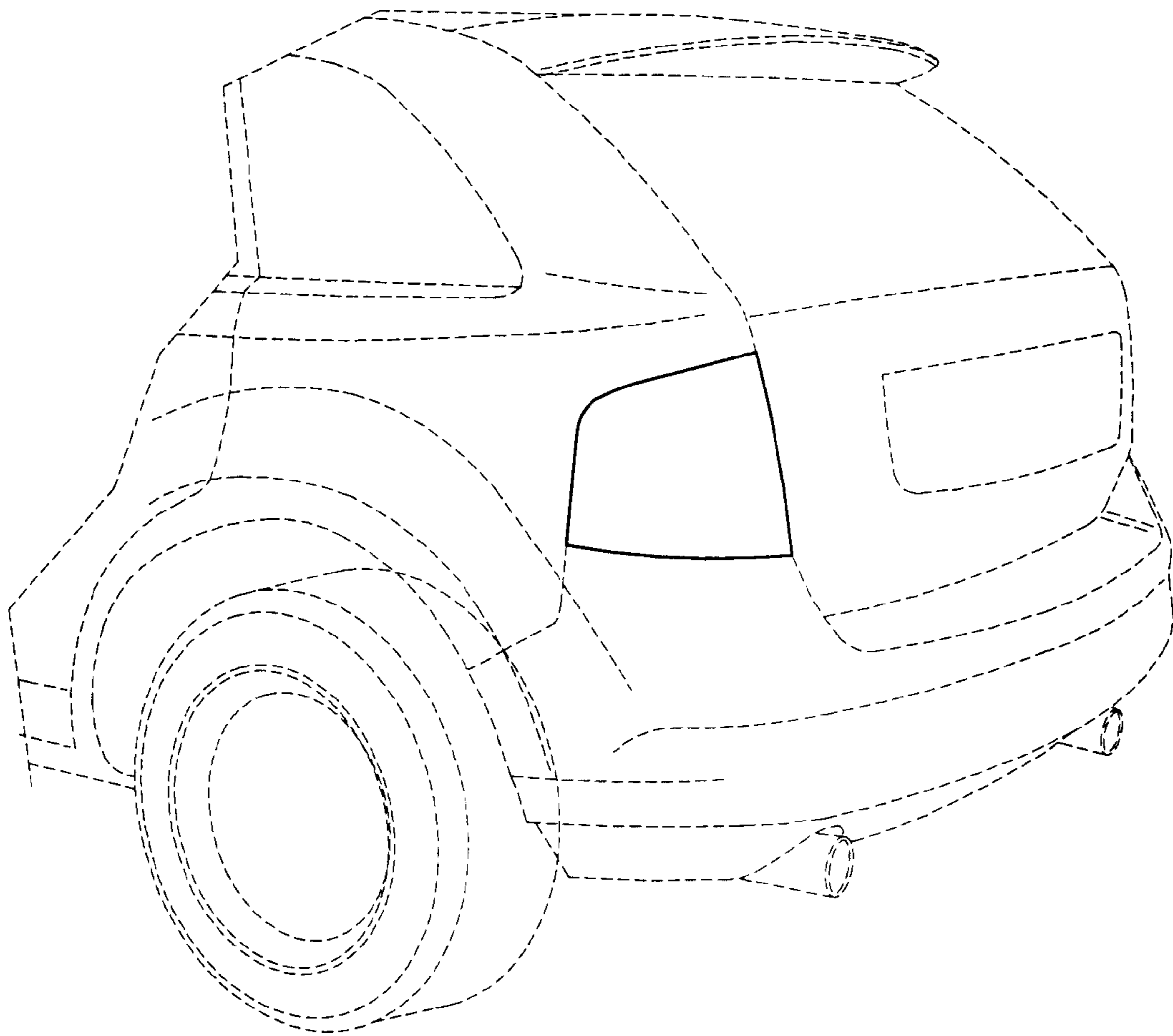


**FIG - 5**

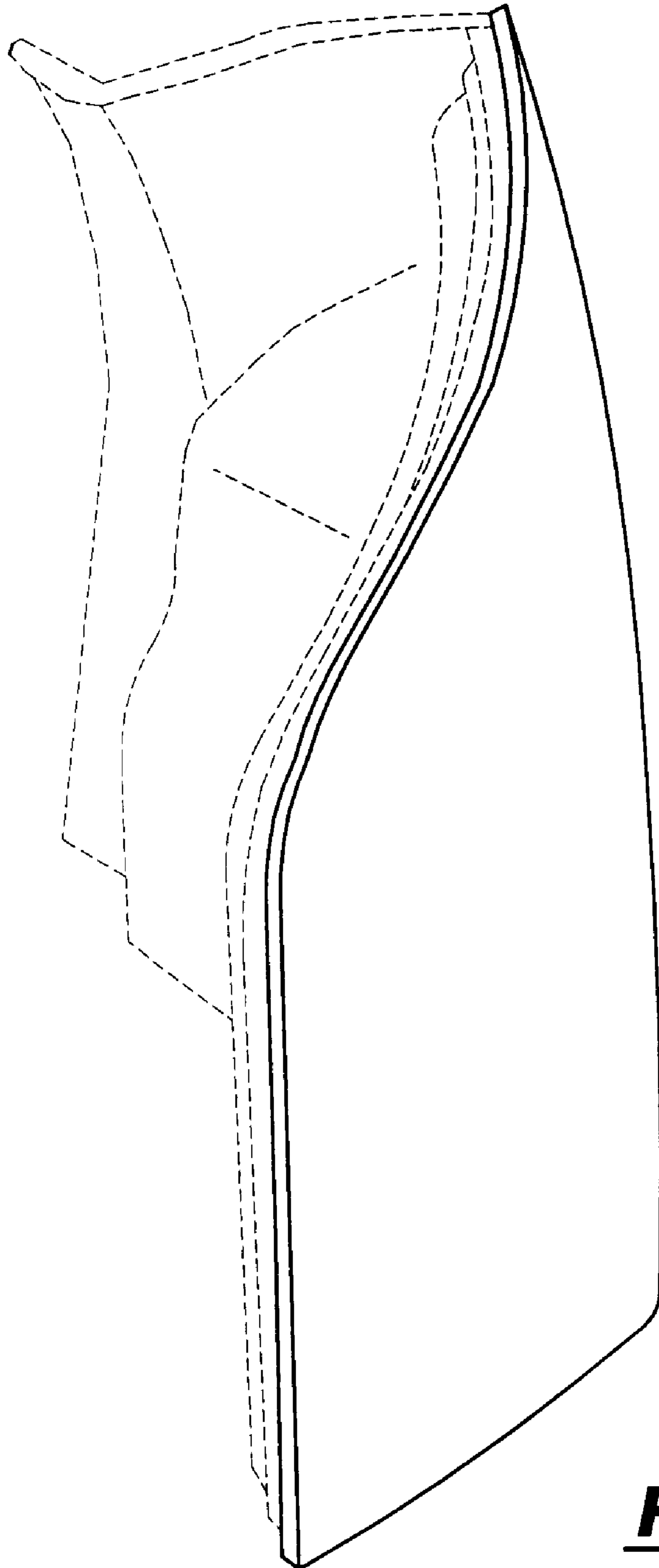


**FIG-6**

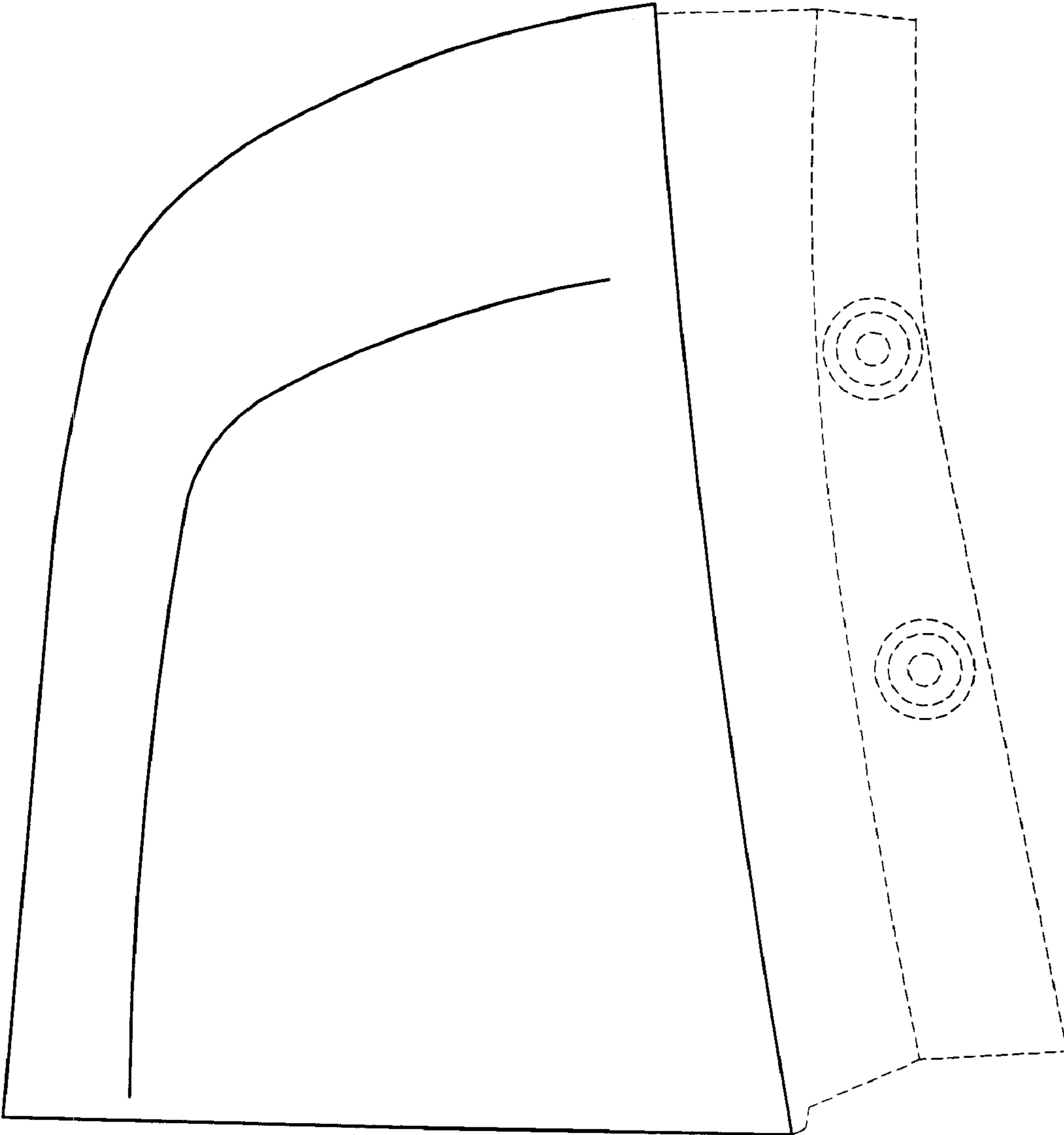




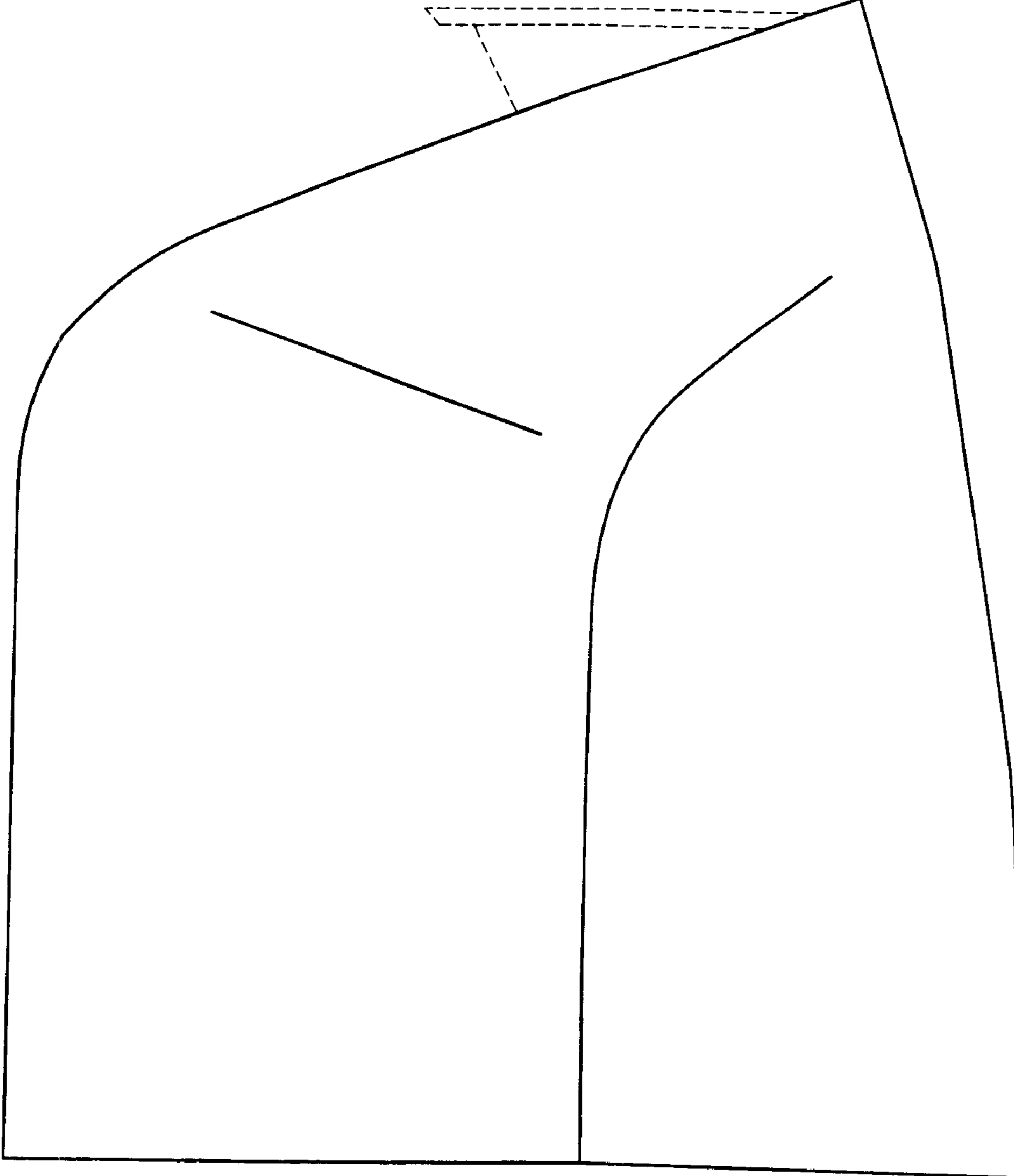
**FIG - 7**



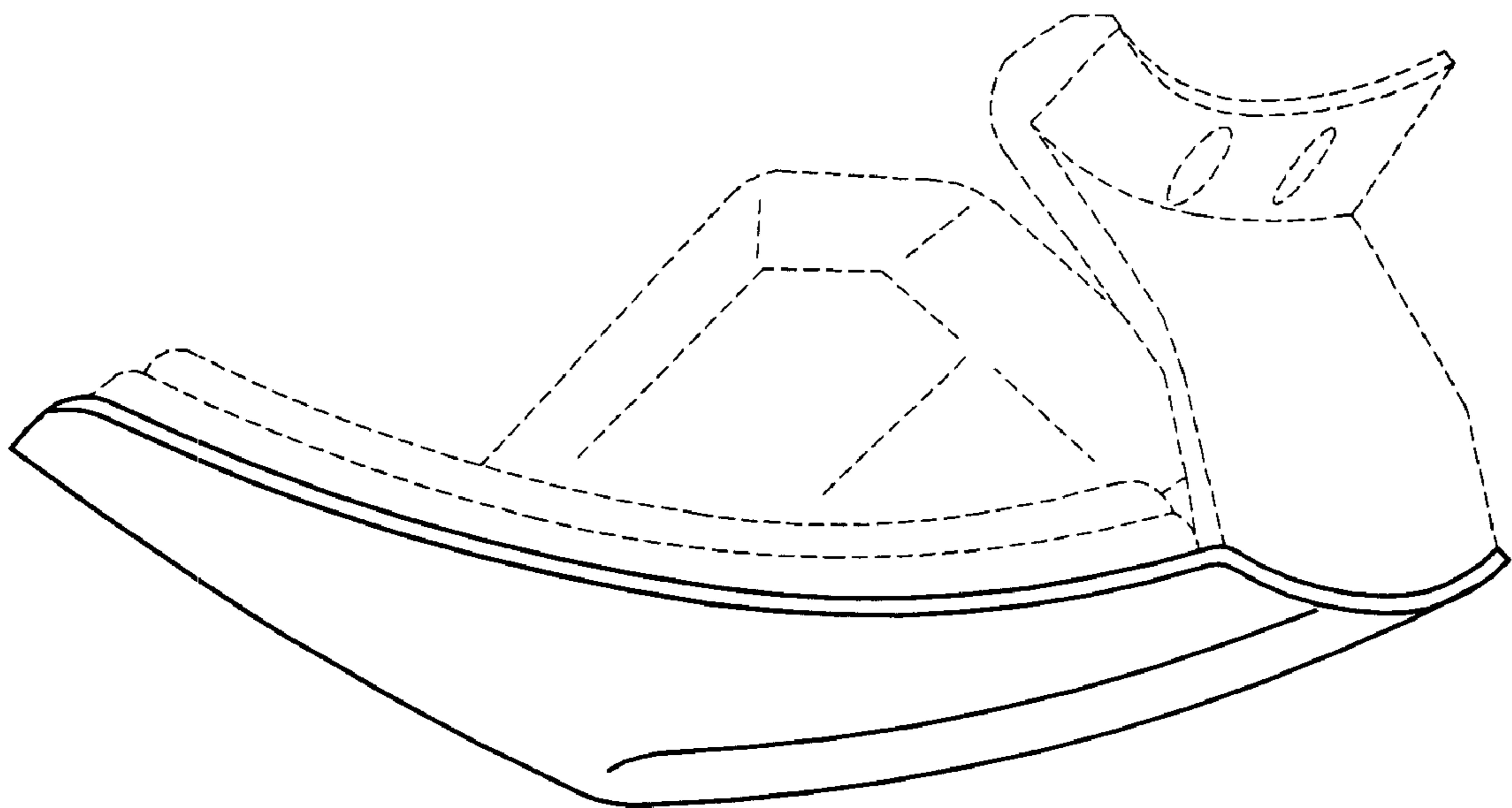
**FIG - 8**



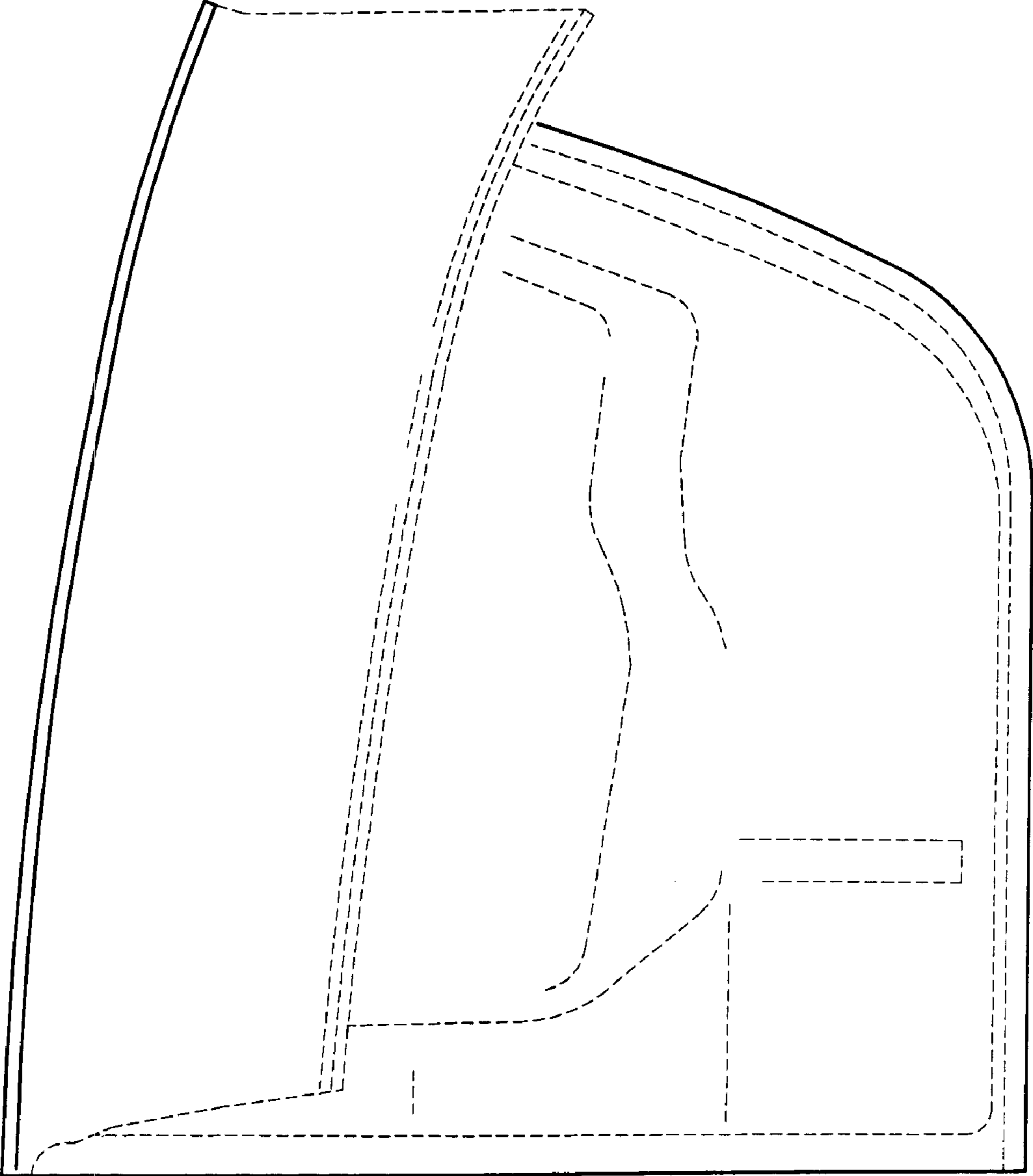
**FIG - 9**



**FIG-10**



**FIG - 11**



**FIG - 12**