



US00D553651S

(12) **United States Design Patent**
Morrison et al.

(10) **Patent No.: US D553,651 S**

(45) **Date of Patent: ** Oct. 23, 2007**

(54) **REFRIGERATOR**

(75) Inventors: **Jasper Morrison**, London (GB); **Jeong Min Kim**, Seoul (KR); **Yun Ho Yang**, Seoul (KR)

(73) Assignee: **Samsung Electronics Co., Ltd.**, Suwon, Kyungki-Do (KR)

(**) Term: **14 Years**

(21) Appl. No.: **29/267,339**

(22) Filed: **Oct. 12, 2006**

(51) **LOC (8) Cl.** **15-07**

(52) **U.S. Cl.** **D15/85**

(58) **Field of Classification Search** D15/79-82, D15/85-89; 62/3.1, 3.6, 3.63, 3.64, 389-400, 62/440, 441, 467, 531; 312/236, 352, 400-406
See application file for complete search history.

(56) **References Cited**

U.S. PATENT DOCUMENTS

D379,095 S *	5/1997	Sparks	D15/85
D477,336 S *	7/2003	Kwak et al.	D15/85
D477,340 S *	7/2003	Kim et al.	D15/85
D513,015 S *	12/2005	Doh et al.	D15/85
D518,076 S *	3/2006	Quinlan et al.	D15/89
D523,878 S *	6/2006	Quinlan et al.	D15/89

D524,832 S *	7/2006	Kim et al.	D15/85
D525,993 S *	8/2006	Kim et al.	D15/85
D527,396 S *	8/2006	Kim et al.	D15/85
D527,397 S *	8/2006	Kim et al.	D15/85
D527,746 S *	9/2006	Kim et al.	D15/85
D534,555 S *	1/2007	Kim et al.	D15/85
2003/0132689 A1 *	7/2003	Shin	312/405

* cited by examiner

Primary Examiner—Stella Reid

Assistant Examiner—Shanda C. Hill

(74) *Attorney, Agent, or Firm*—Ladas & Parry LLP

(57) **CLAIM**

We claim the ornamental design for a refrigerator, as shown.

DESCRIPTION

FIG. 1 is a perspective view as seen from the top, front, and left side of a refrigerator showing our new design;

FIG. 2 is a front elevational view thereof;

FIG. 3 is a rear elevational view thereof;

FIG. 4 is a left side elevational view thereof;

FIG. 5 is a right side elevational view thereof;

FIG. 6 is a top plan view thereof; and,

FIG. 7 is a bottom plan view thereof.

1 Claim, 6 Drawing Sheets

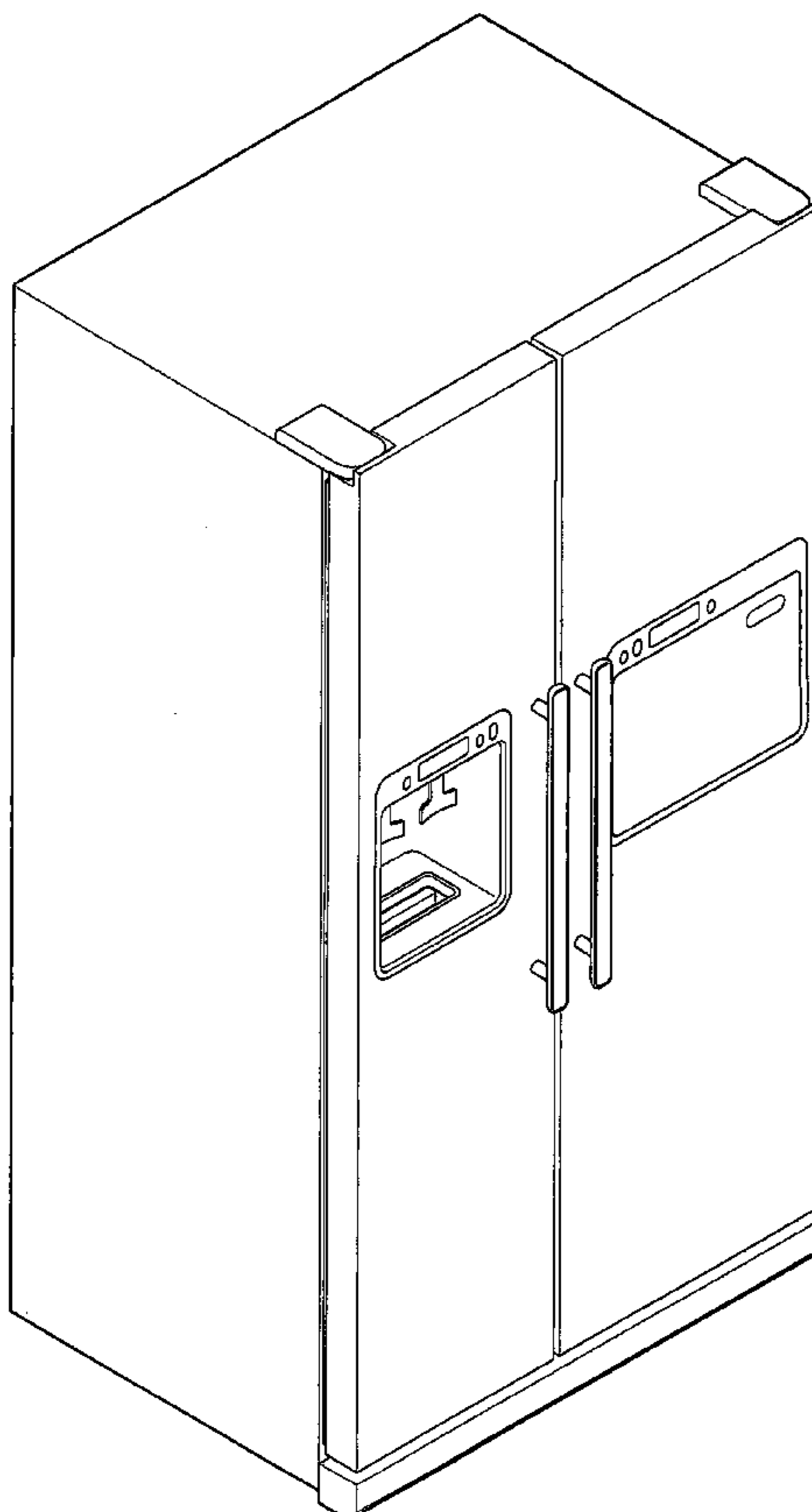

FIG. 1

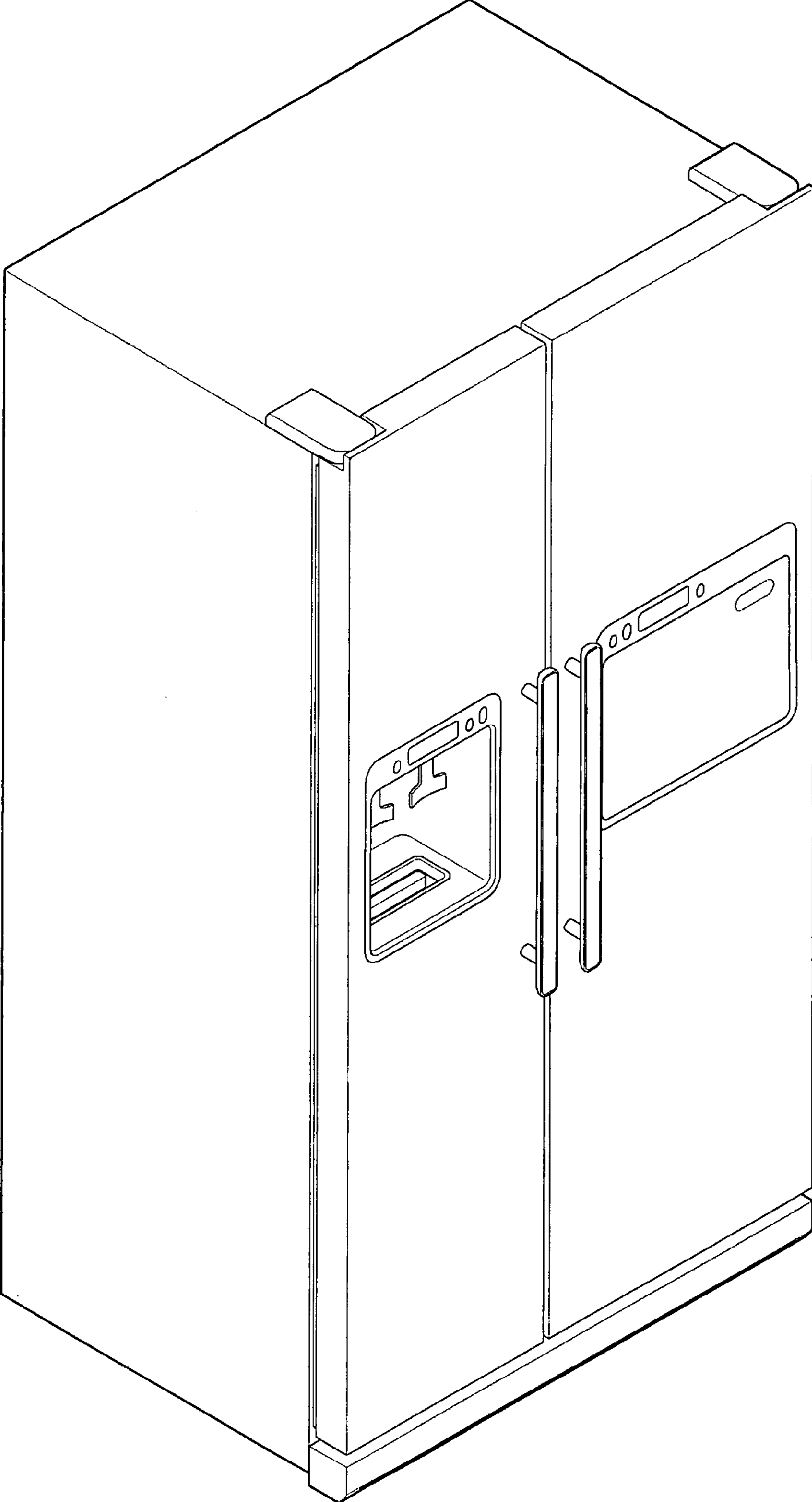

FIG. 2

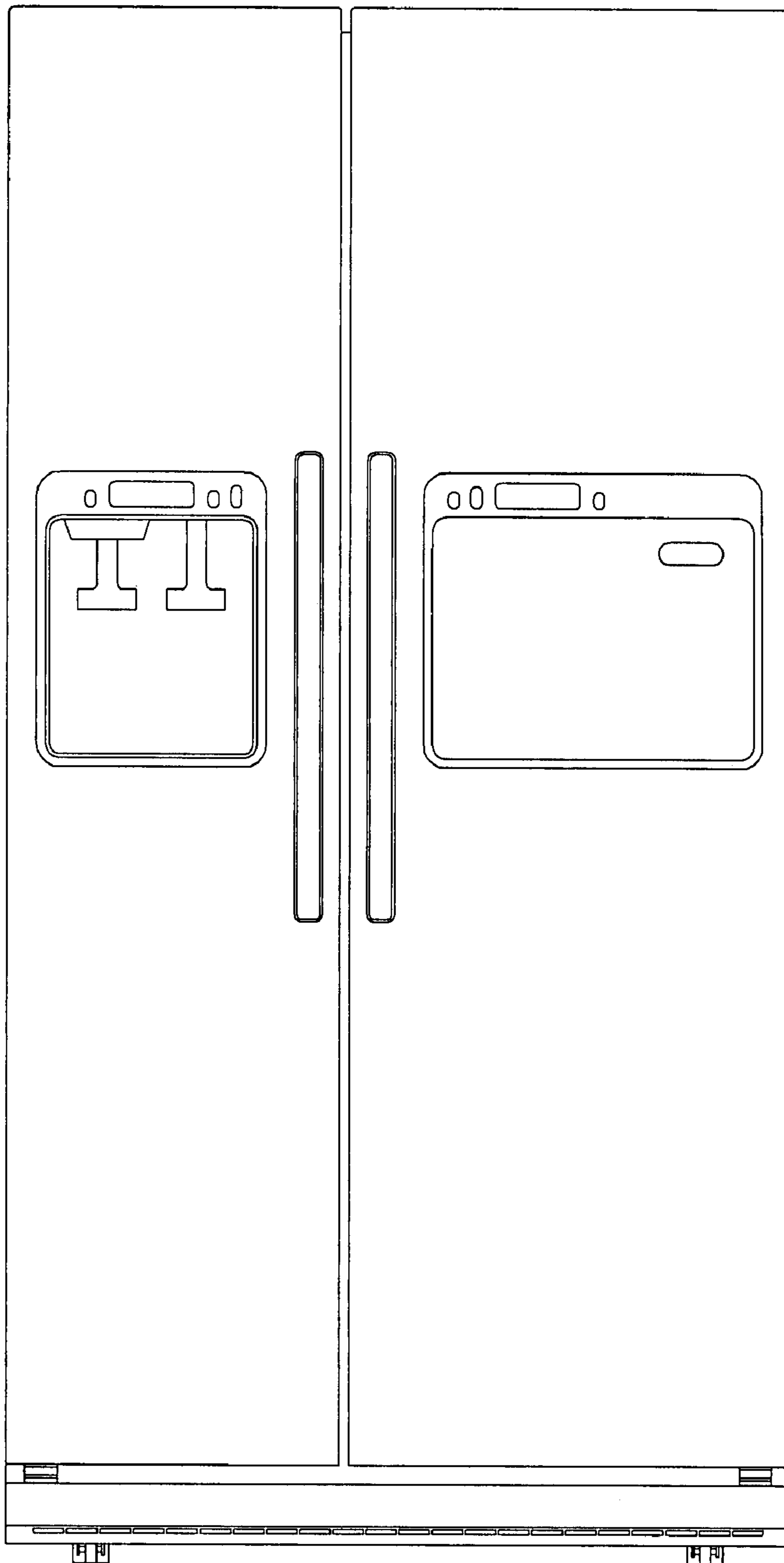

FIG. 3

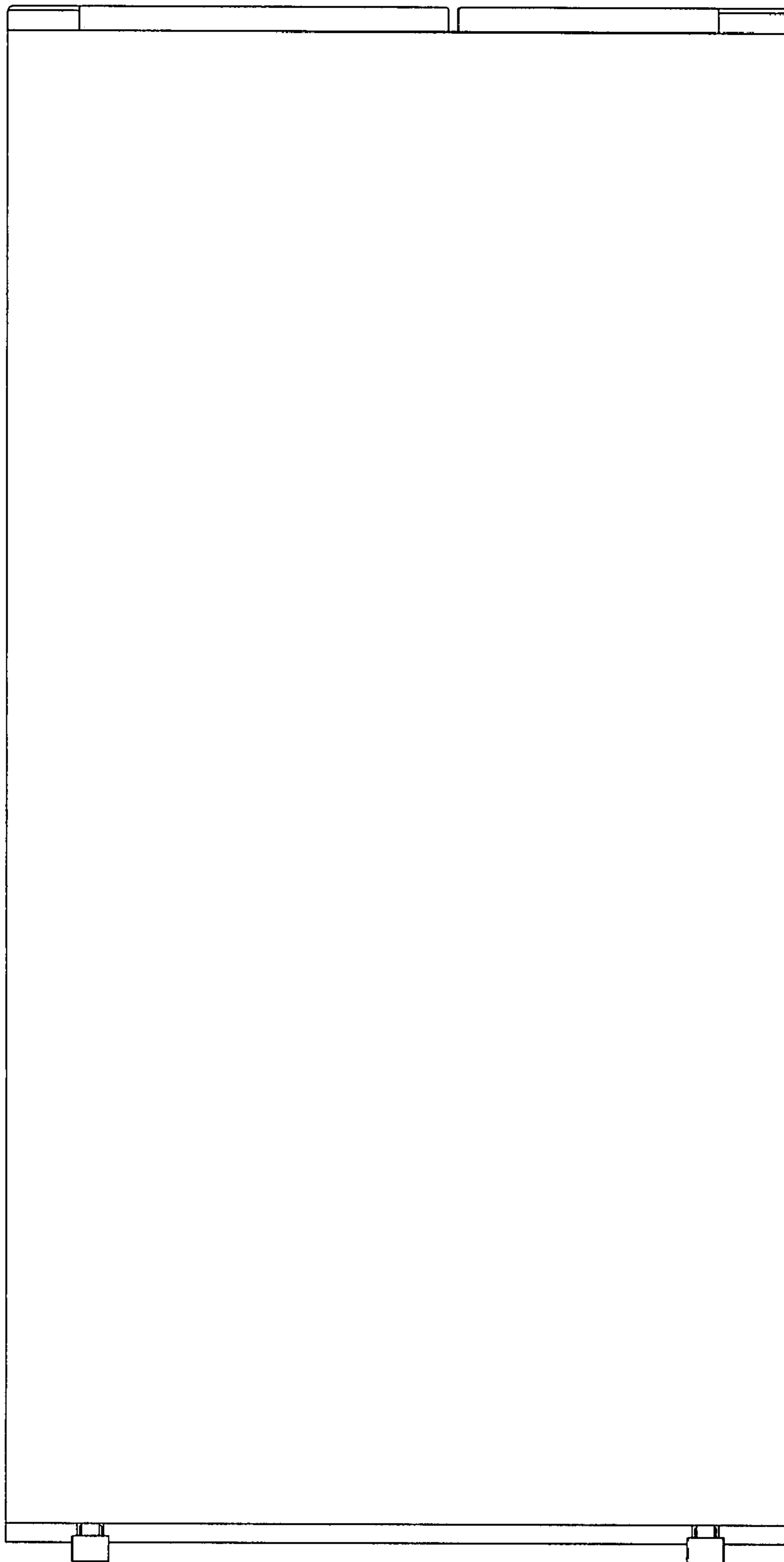

FIG. 4

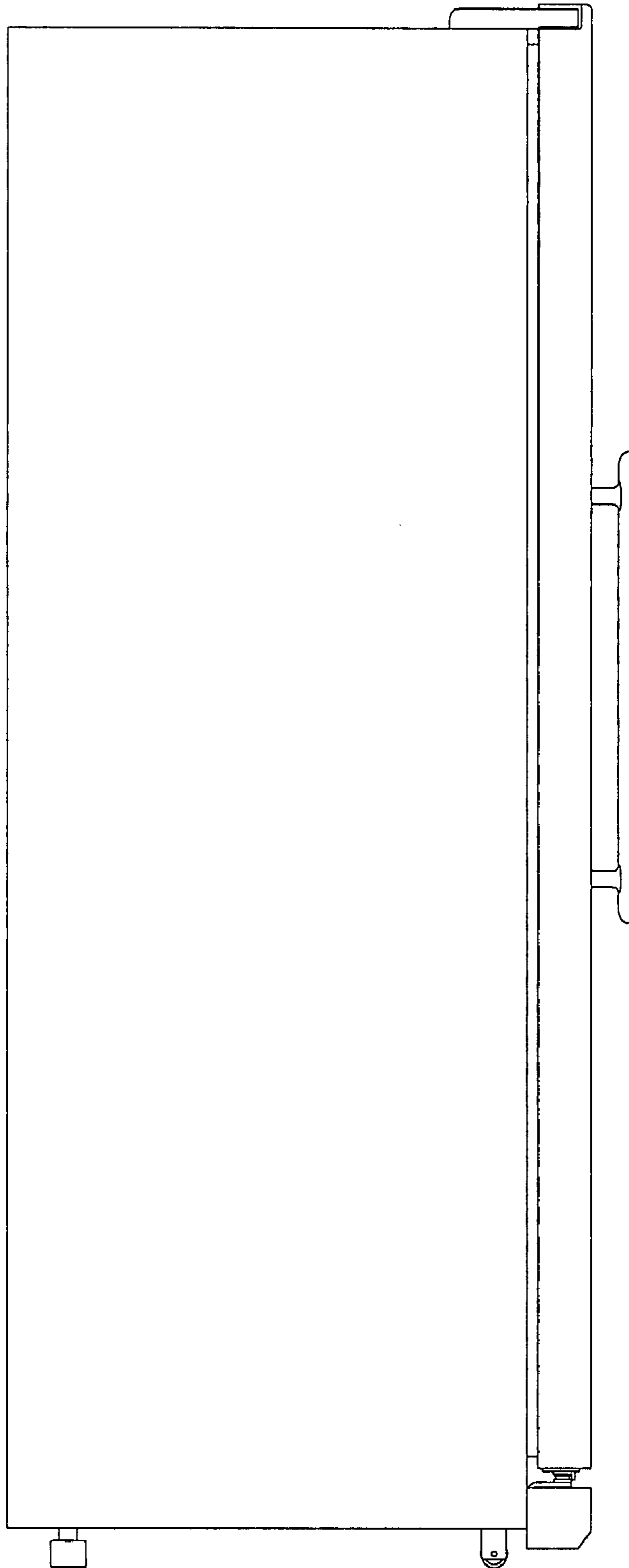

FIG. 5

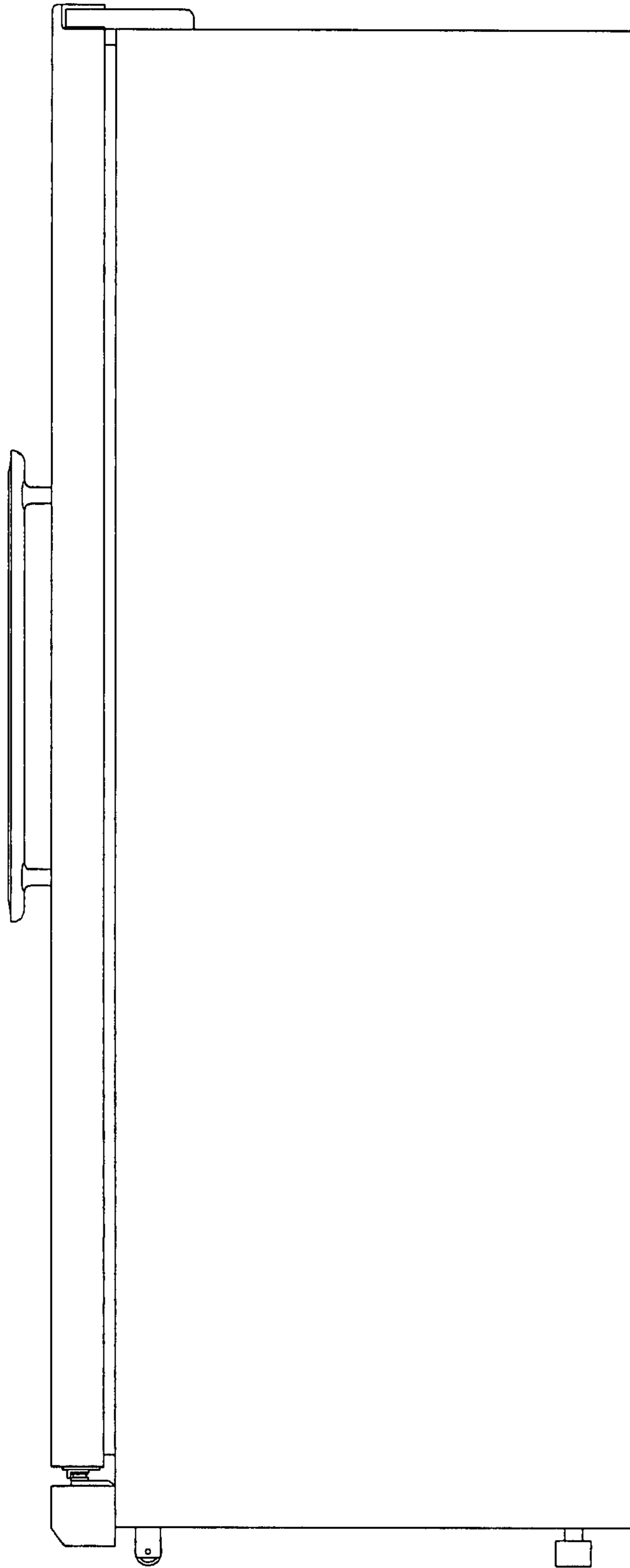

FIG. 6

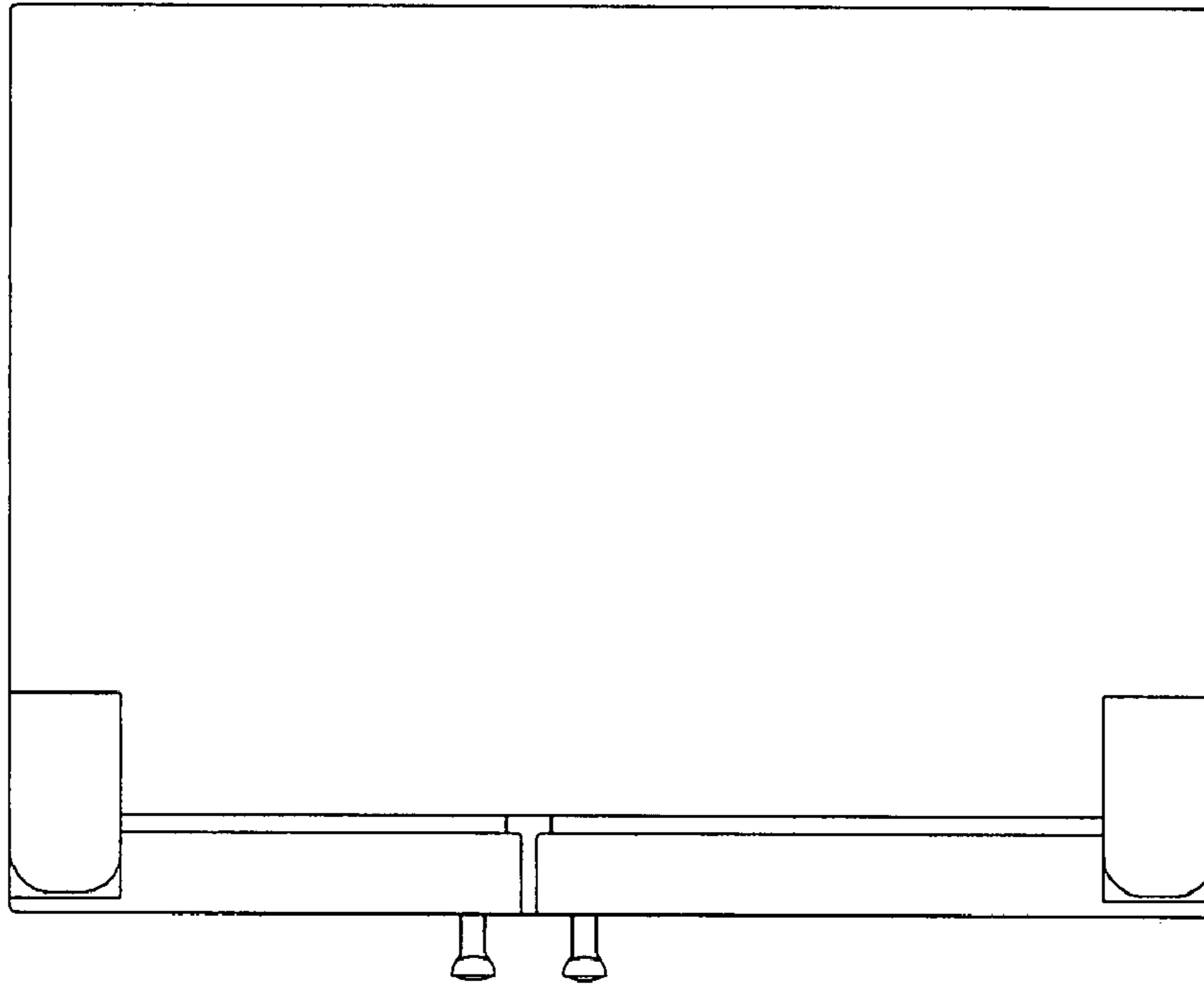

FIG. 7

