



US00D553249S

(12) **United States Design Patent**
Wakisaka et al.

(10) **Patent No.:** **US D553,249 S**
(45) **Date of Patent:** **** Oct. 16, 2007**

(54) **PROBE FOR AN ULTRASONIC DIAGNOSIS APPARATUS**

(75) Inventors: **Yoshinori Wakisaka**, Tokyo (JP);
Masahiko Kitayama, Mitaka (JP); **Kei Tomioka**, Tokyo (JP); **Hideki Kosaku**,
Nasushiobara (JP)

(73) Assignees: **Kabushiki Kaisha Toshiba** (JP);
Toshiba Medical Systems Corporation
(JP)

(**) Term: **14 Years**

(21) Appl. No.: **29/277,635**

(22) Filed: **Mar. 5, 2007**

(30) **Foreign Application Priority Data**

Nov. 9, 2006 (JP) 2006-030769

(51) **LOC (8) Cl.** **24-01**

(52) **U.S. Cl.** **D24/186**

(58) **Field of Classification Search** D24/186,
D24/187; D10/60; 128/660.01-660.09,
128/660.1, 662.03-662.06; 310/17, 334;
600/439, 443, 446, 459; 601/2, 4; 604/22;
606/169; 433/86, 119

See application file for complete search history.

(56) **References Cited**

U.S. PATENT DOCUMENTS

5,322,055 A * 6/1994 Davison et al. 601/2
5,582,588 A * 12/1996 Sakurai et al. 604/22

5,776,155 A * 7/1998 Beaupre et al. 604/22
5,957,943 A * 9/1999 Vaitekunas 604/22
6,117,152 A * 9/2000 Huitema 606/169
6,139,561 A * 10/2000 Shibata et al. 606/169
6,206,844 B1 * 3/2001 Reichel et al. 601/2
6,328,703 B1 * 12/2001 Murakami 601/4
6,416,525 B1 * 7/2002 Shibata 604/22
6,761,698 B2 * 7/2004 Shibata et al. 601/2
6,811,399 B2 * 11/2004 Rahman et al. 433/119
7,011,520 B2 * 3/2006 Rahman et al. 433/86
7,131,983 B2 * 11/2006 Murakami 606/169

* cited by examiner

Primary Examiner—Catherine R. Oliver

Assistant Examiner—Mark Cavanna

(74) *Attorney, Agent, or Firm*—Banner & Witcoff, Ltd.

(57) **CLAIM**

The ornamental design for a probe for an ultrasonic diagnosis apparatus, as shown and described.

DESCRIPTION

FIG. 1 is a front, top and left side perspective view of a probe for an ultrasonic diagnosis apparatus, showing our new design;

FIG. 2 is a rear elevational view thereof;

FIG. 3 is a front elevational view thereof;

FIG. 4 is a top plan view thereof;

FIG. 5 is a bottom plan view thereof;

FIG. 6 is a left side elevational view thereof; and,

FIG. 7 is a right side elevational view thereof.

1 Claim, 2 Drawing Sheets

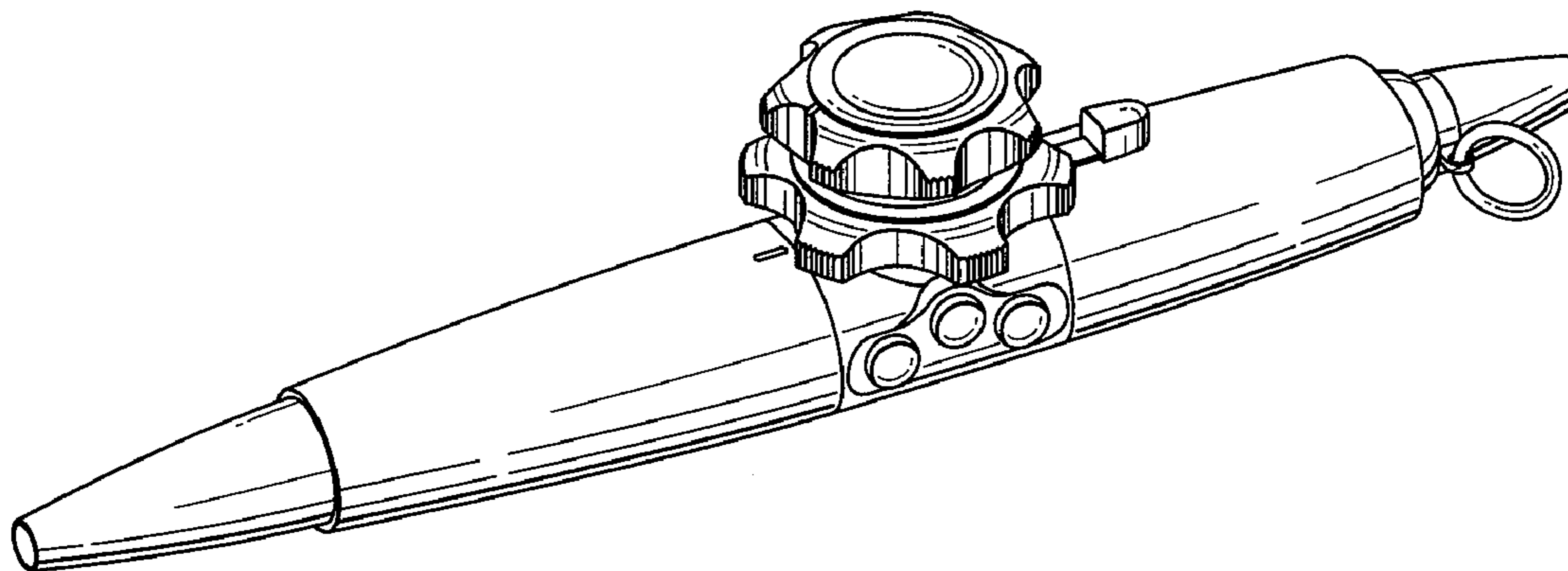

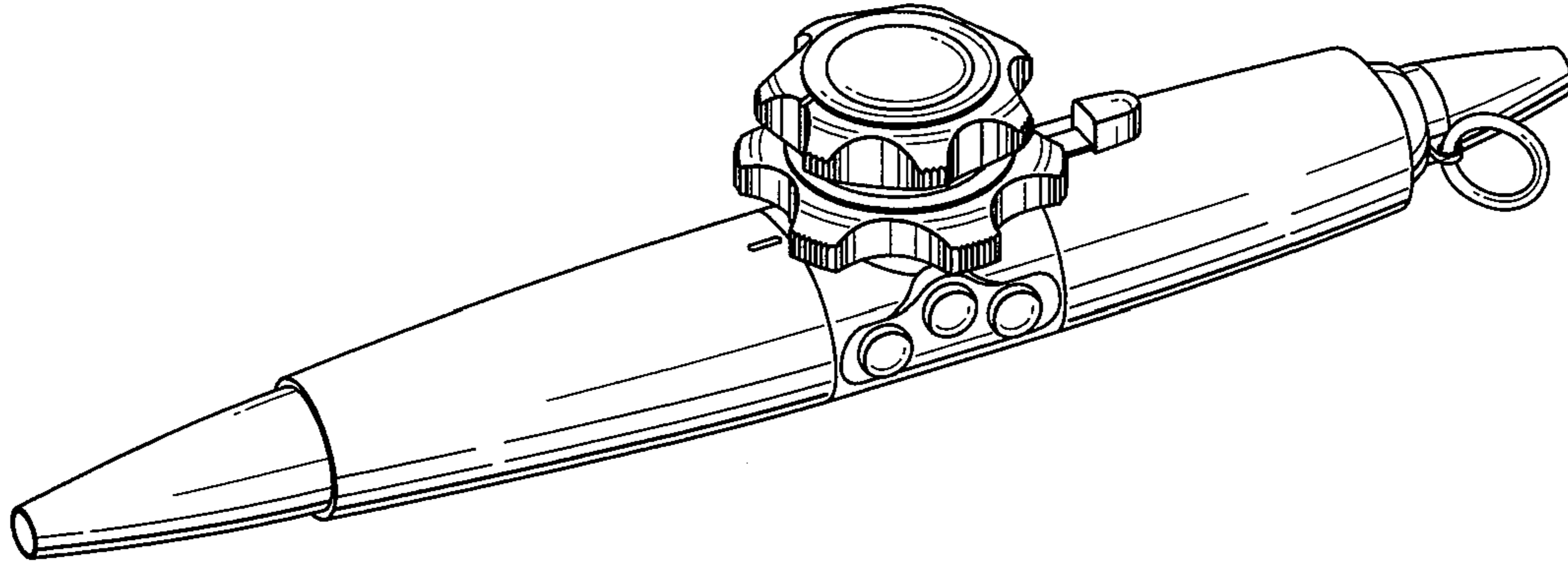

FIG. 1

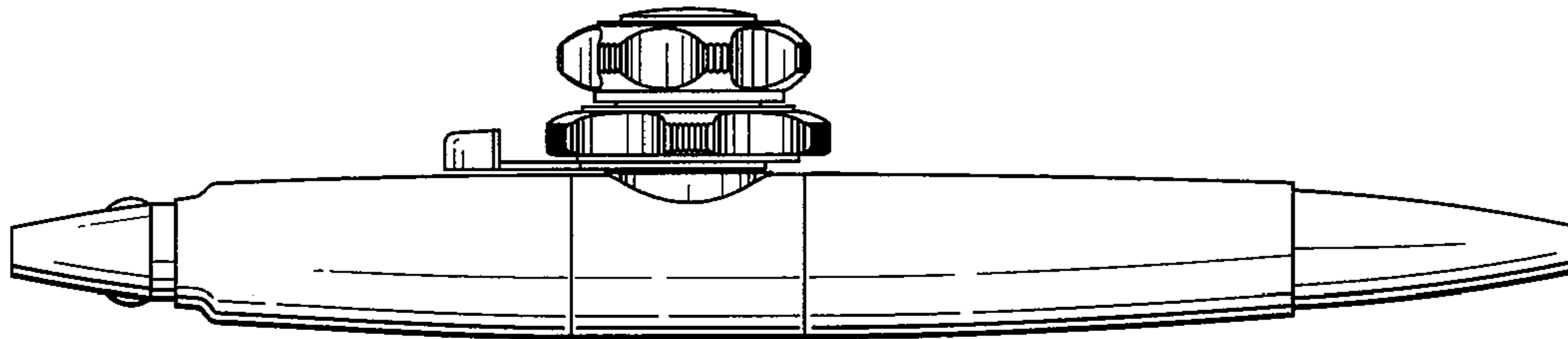

FIG. 2

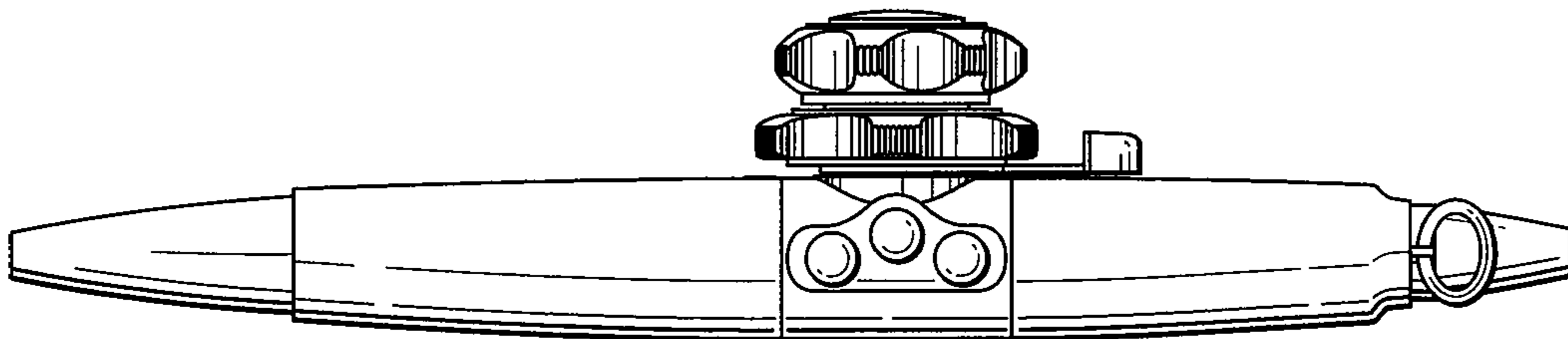

FIG. 3

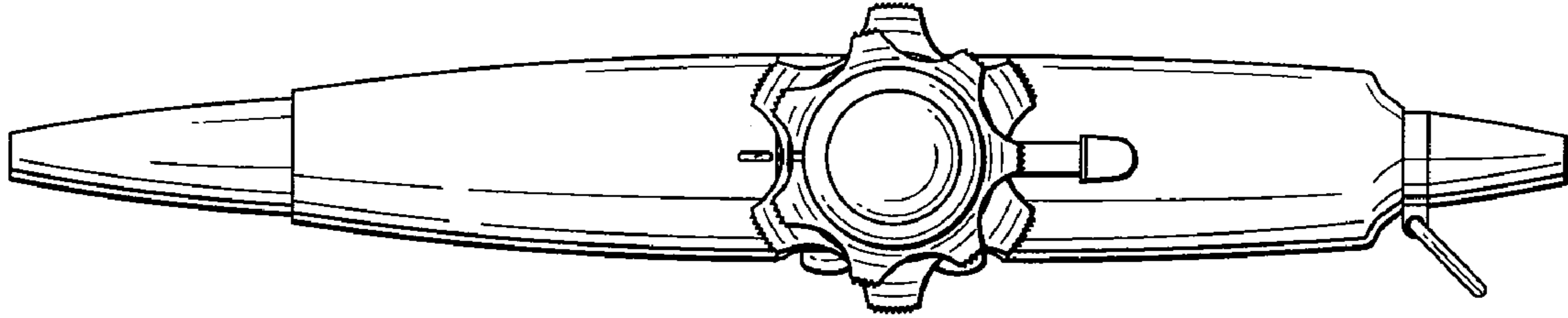

FIG. 4

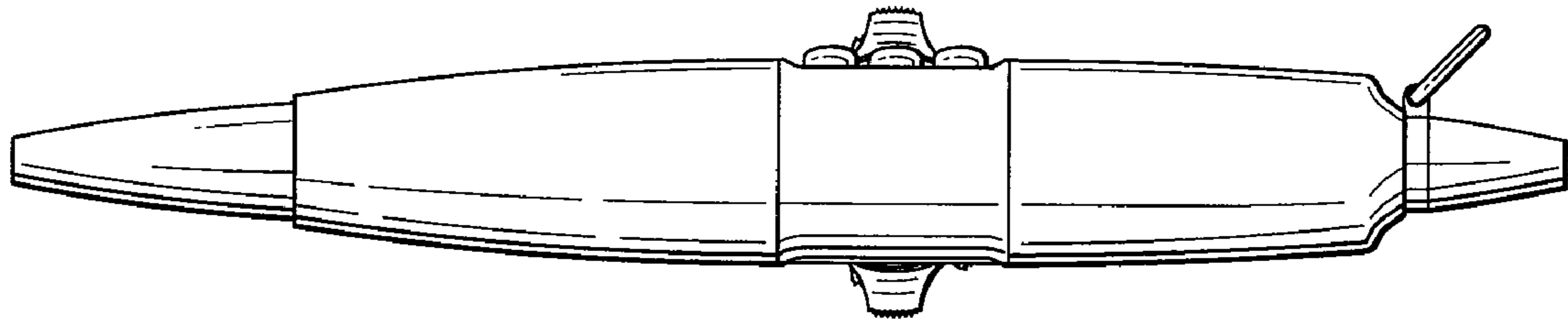

FIG. 5

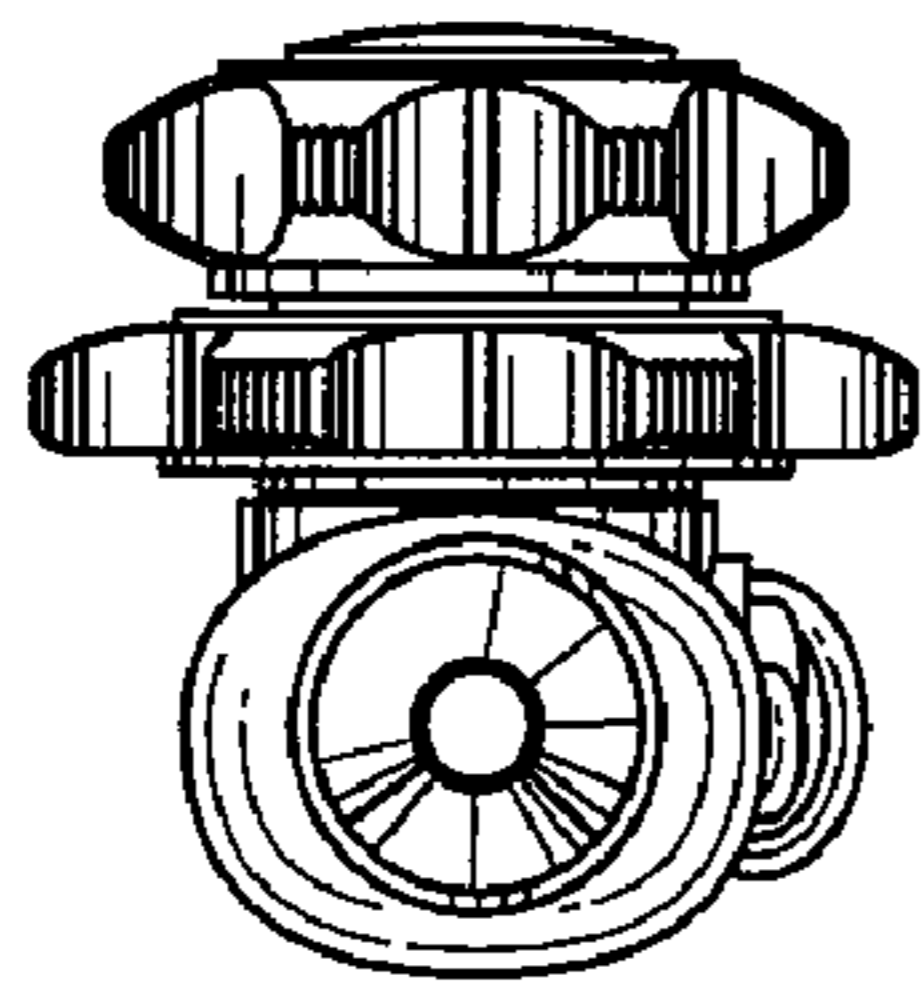

FIG. 6

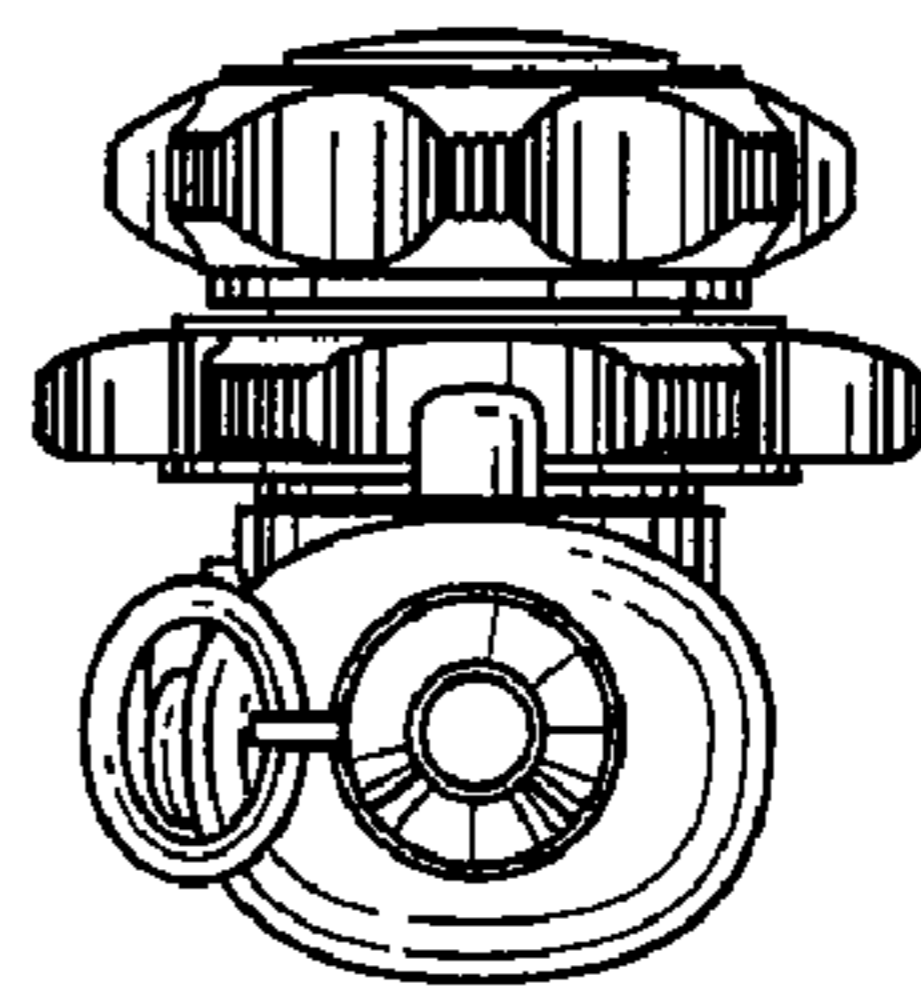

FIG. 7