



US00D553072S

(12) **United States Design Patent**
Smith

(10) **Patent No.:** **US D553,072 S**

(45) **Date of Patent:** **** Oct. 16, 2007**

(54) **TAILGATE CARGO ENCLOSURE**

(57) **CLAIM**

(75) Inventor: **Anthony Smith**, Costa Mesa, CA (US)

The ornamental design for a tailgate cargo enclosure, as shown and described.

(73) Assignee: **American Moto Products, Inc.**, Irvine, CA (US)

(**) Term: **14 Years**

DESCRIPTION

(21) Appl. No.: **29/250,210**

The claimed tailgate cargo enclosure is used to extend the cargo bed of a vehicle and could be mounted on a truck.

(22) Filed: **Nov. 6, 2006**

FIG. 1 is a perspective view of a tailgate cargo enclosure illustrating our new design mounted on a rear portion of a vehicle.

(51) **LOC (8) Cl.** **12-16**

(52) **U.S. Cl.** **D12/414**

(58) **Field of Classification Search** D12/400, D12/414, 414.1, 196, 221, 107; 224/402-405, 224/521, 526, 495-498, 502; 296/26.08-26.11, 296/37.1, 37.6, 26, 180.1, 50-51, 57.1
See application file for complete search history.

FIG. 2 is a front perspective view of the tailgate cargo enclosure of FIG. 1.

FIG. 3 is a rear elevational view of the tailgate cargo enclosure of FIG. 1.

(56) **References Cited**

U.S. PATENT DOCUMENTS

5,658,033	A *	8/1997	Delaune	296/26.08
5,700,047	A *	12/1997	Leitner et al.	296/26.11
D417,859	S *	12/1999	Leitner et al.	D12/414
D418,106	S *	12/1999	Leitner et al.	D12/414
6,113,173	A *	9/2000	Leitner et al.	296/26.11
6,425,618	B1 *	7/2002	Garland et al.	296/3
6,719,345	B2 *	4/2004	Ootsuka et al.	296/26.08
6,994,389	B1 *	2/2006	Graffy et al.	296/26.11
7,007,995	B1 *	3/2006	Scarberry et al.	296/26.11
7,121,604	B2 *	10/2006	Reed	296/26.11
7,159,918	B2 *	1/2007	Lussier	296/26.09

FIG. 4 is a front elevational view of the tailgate cargo enclosure of FIG. 1.

FIG. 5 is a top plan view of the tailgate cargo enclosure of FIG. 1.

FIG. 6 is a bottom plan view of the tailgate cargo enclosure of FIG. 1.

FIG. 7 is a left side view of the tailgate cargo enclosure of FIG. 1; and,

FIG. 8 is a right side view of the tailgate cargo enclosure of FIG. 1.

* cited by examiner

The broken line showing of environment is for illustrative purposes only and forms no part of the claimed design.

The tailgate cargo enclosure is shown on an enlarged scale in FIGS. 2-8.

Primary Examiner—Stacia Cadmus

(74) *Attorney, Agent, or Firm*—Knobbe, Martens, Olson & Bear LLP

1 Claim, 7 Drawing Sheets

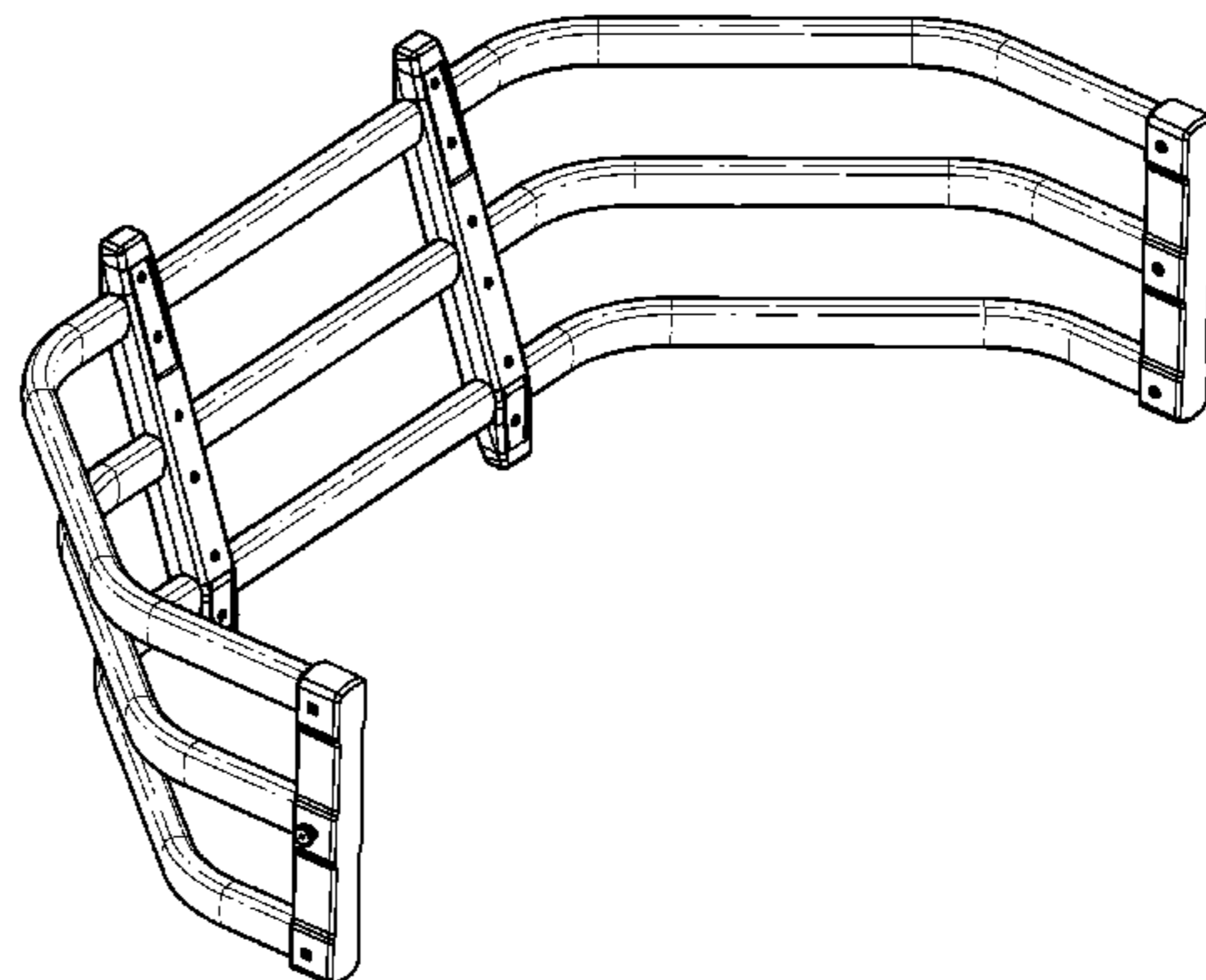
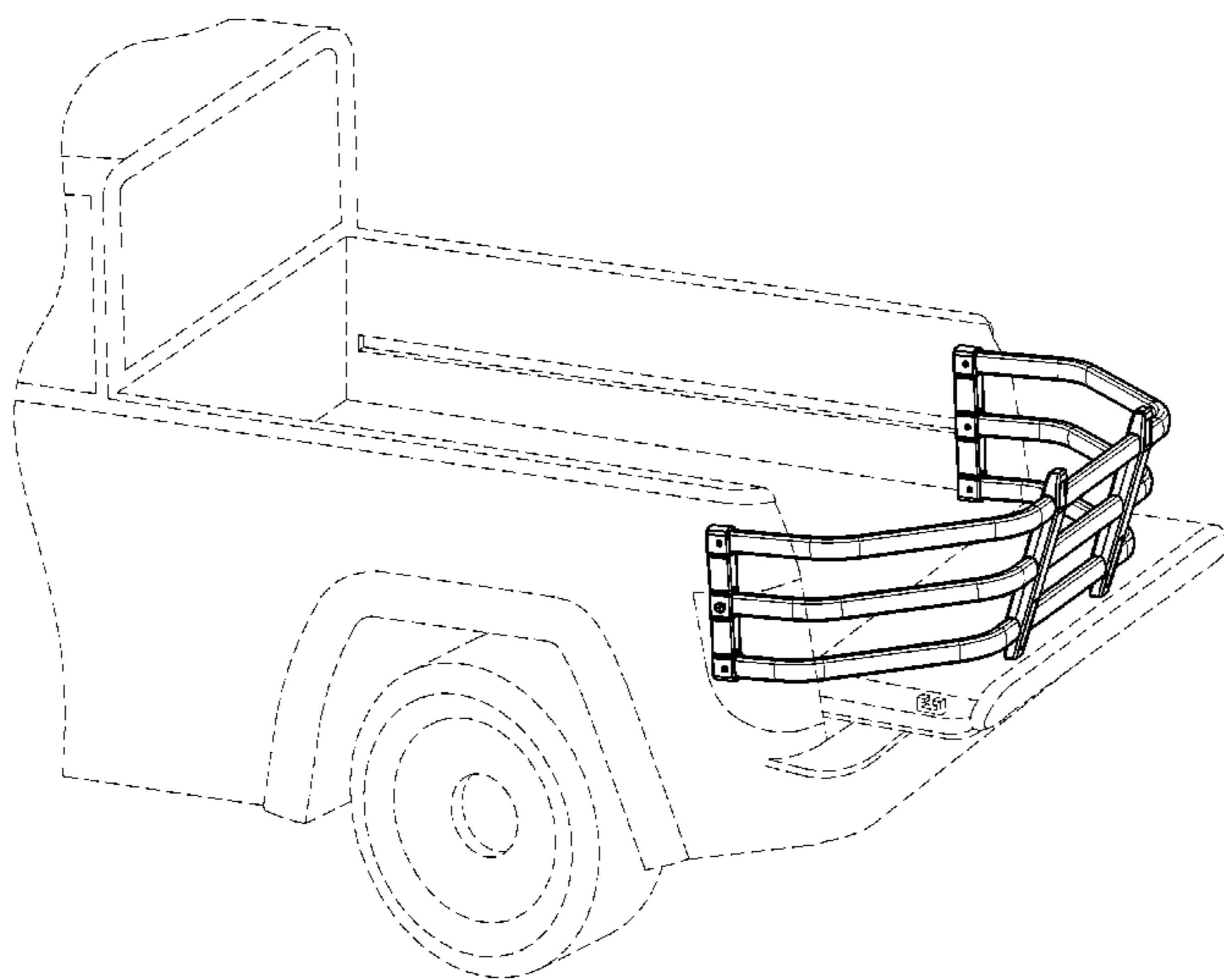

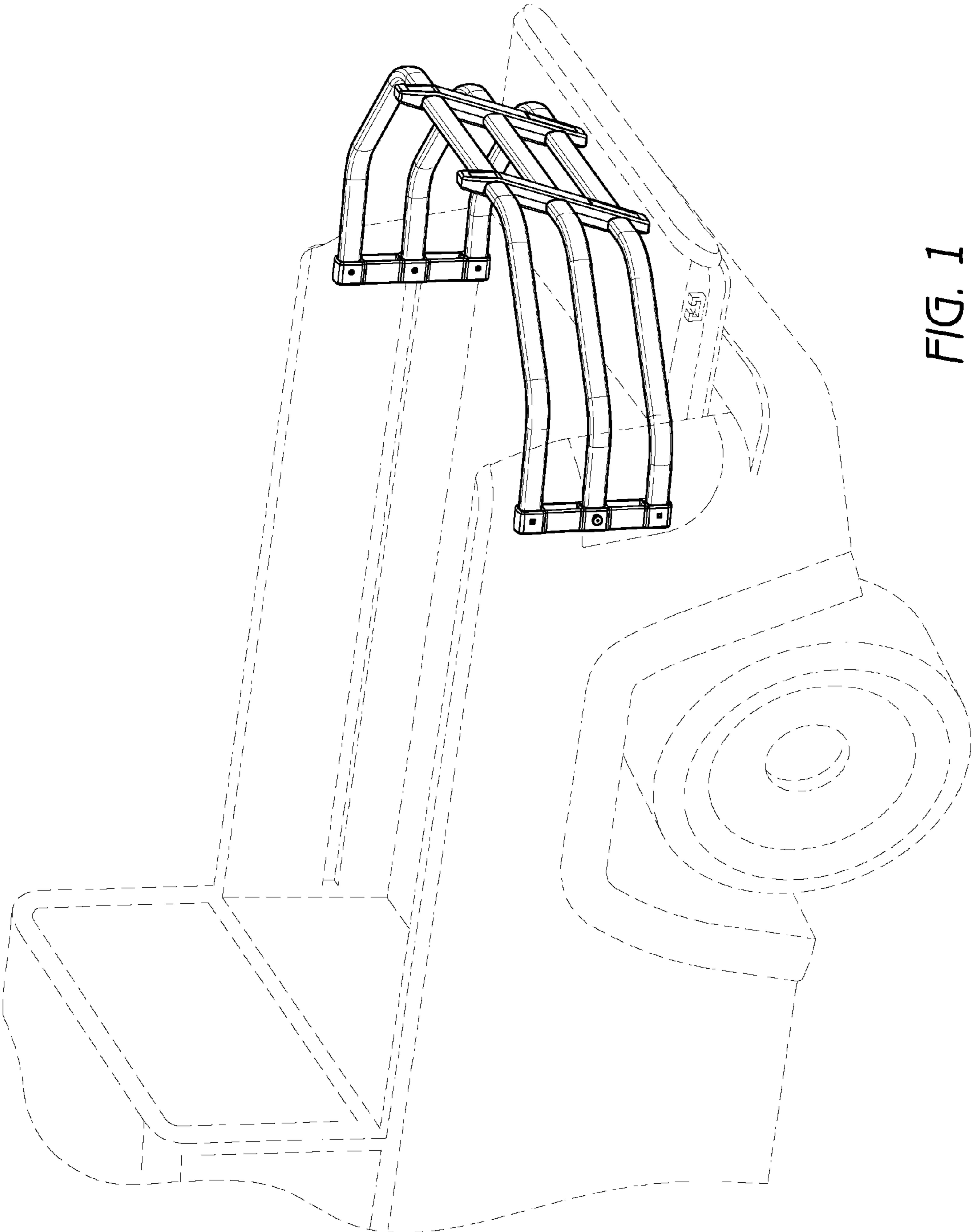

FIG. 1

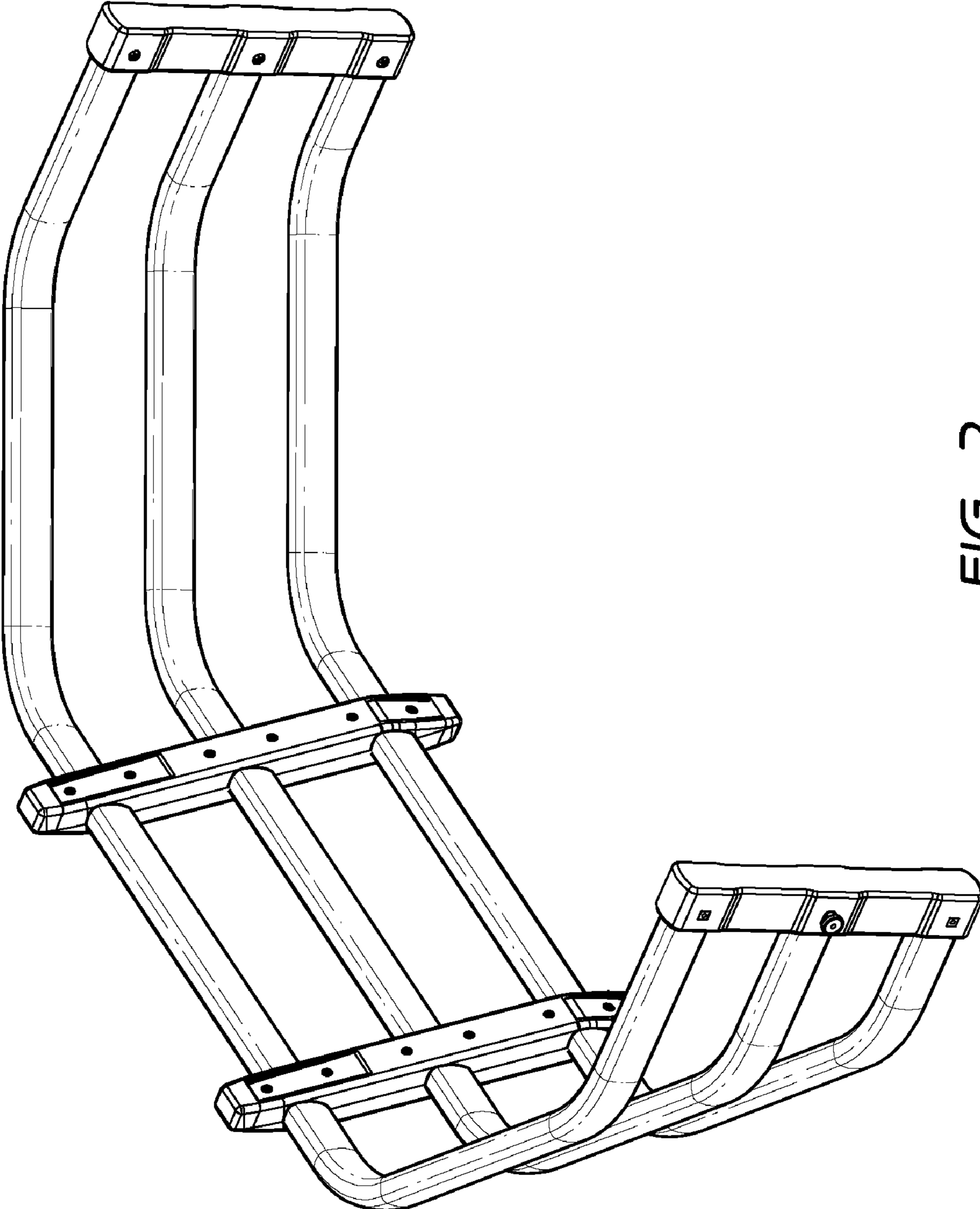

FIG. 2

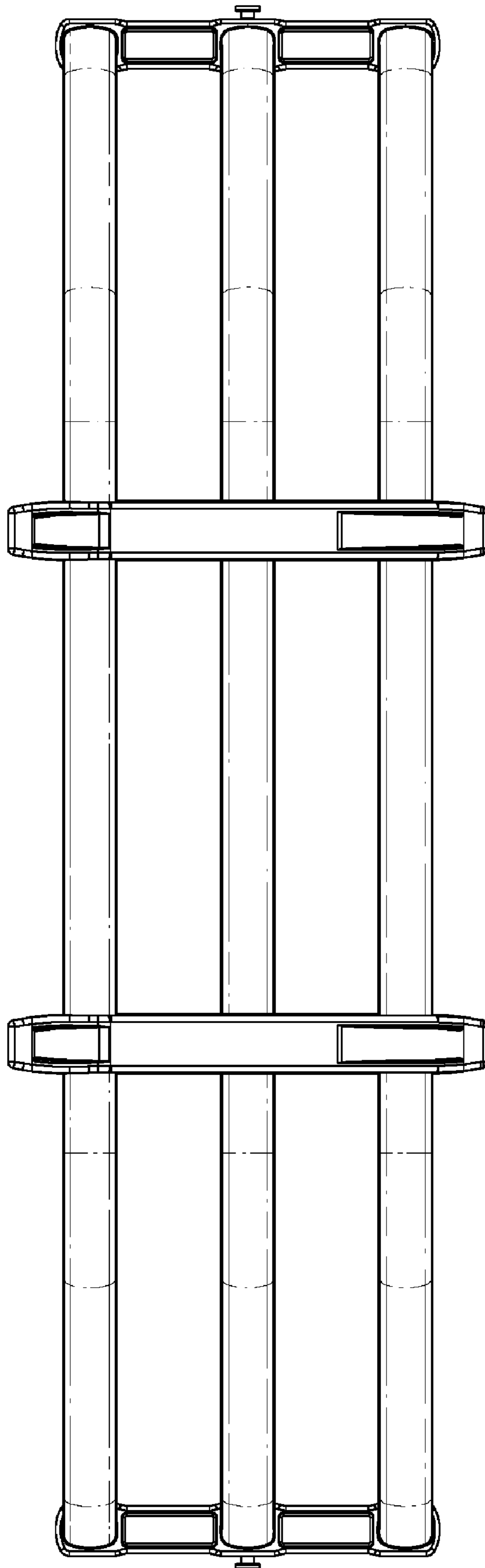

FIG. 3

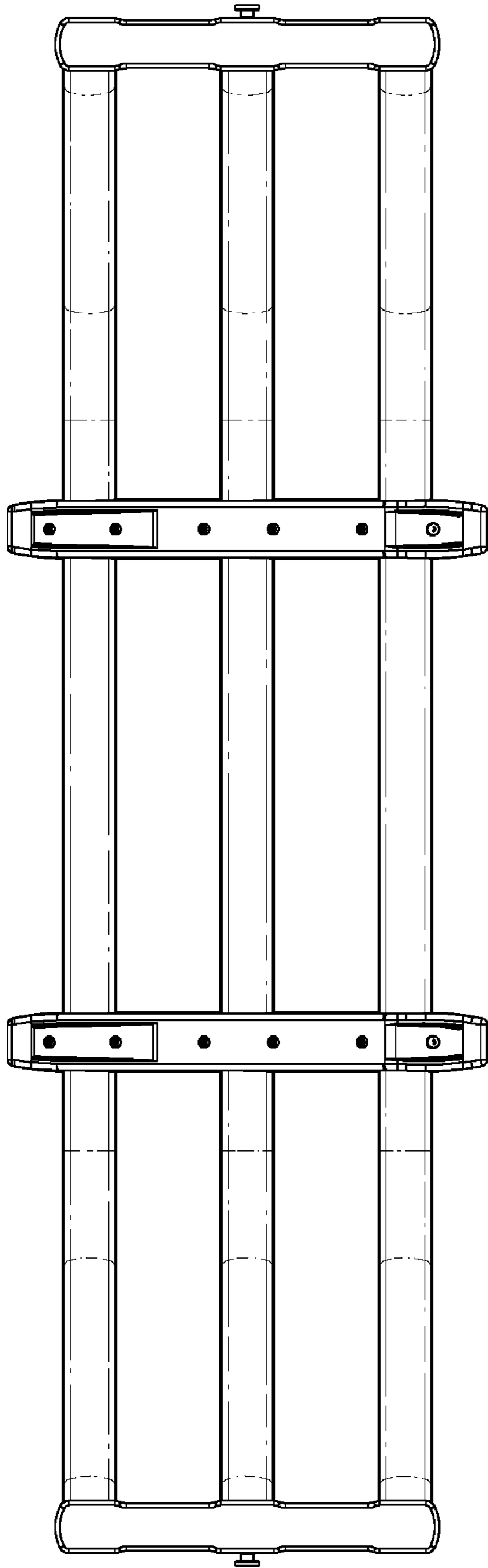

FIG. 4

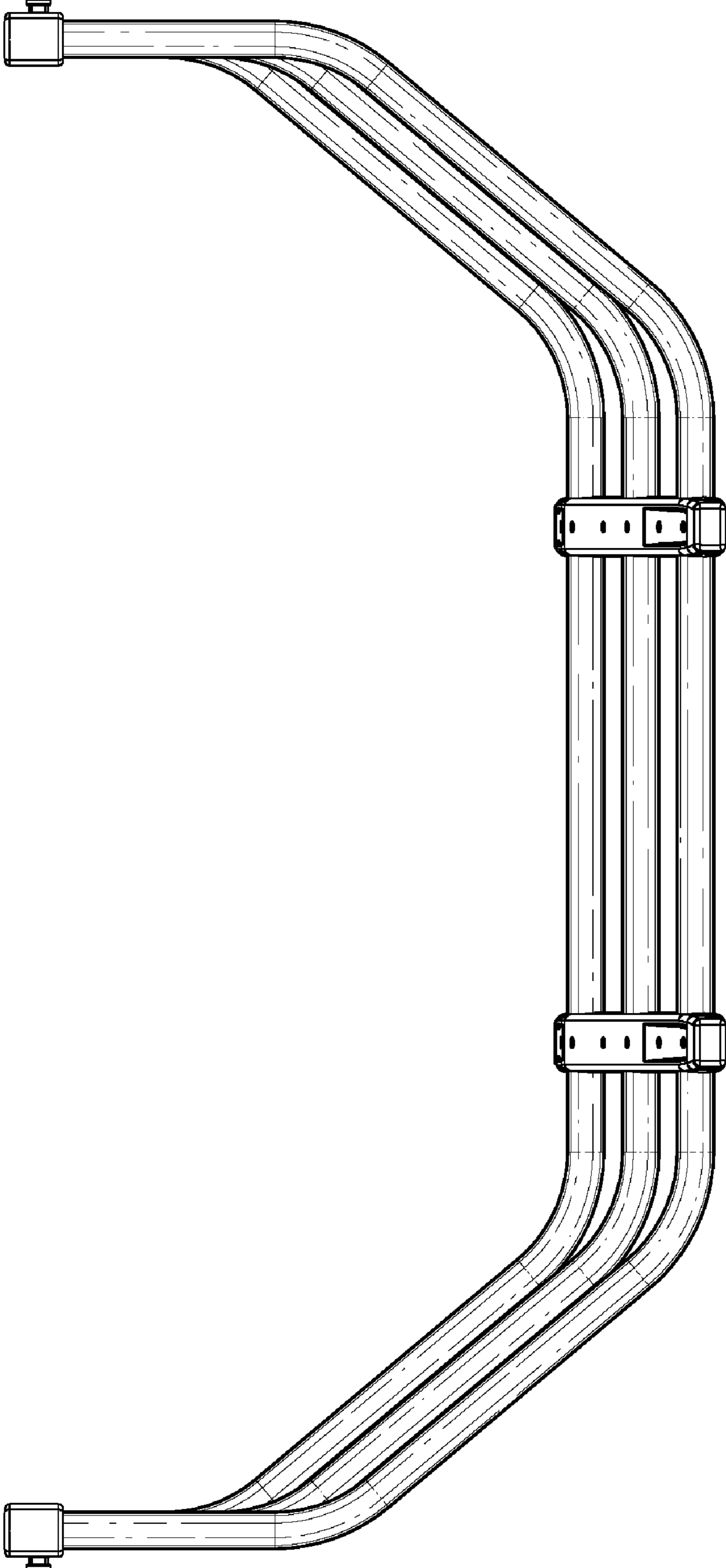

FIG. 5

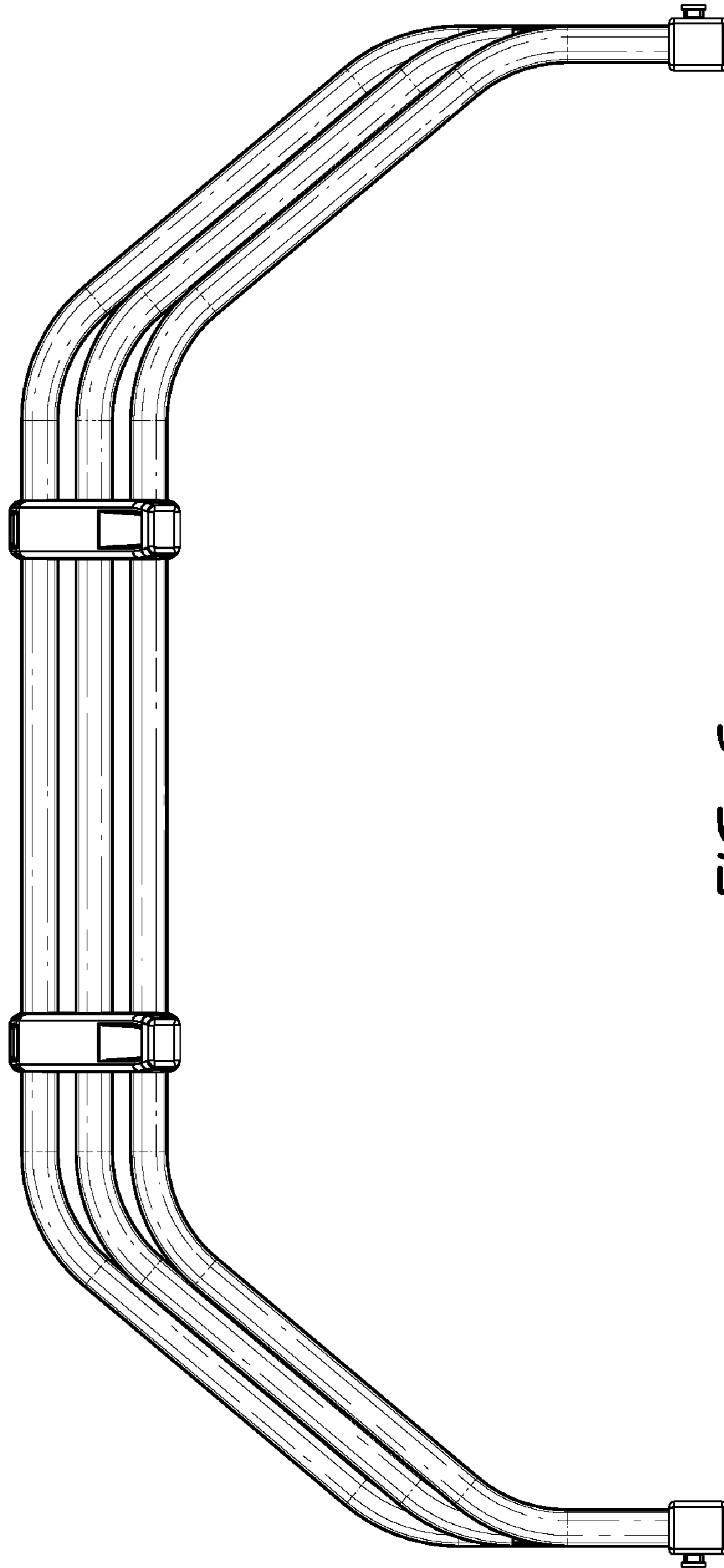

FIG. 6

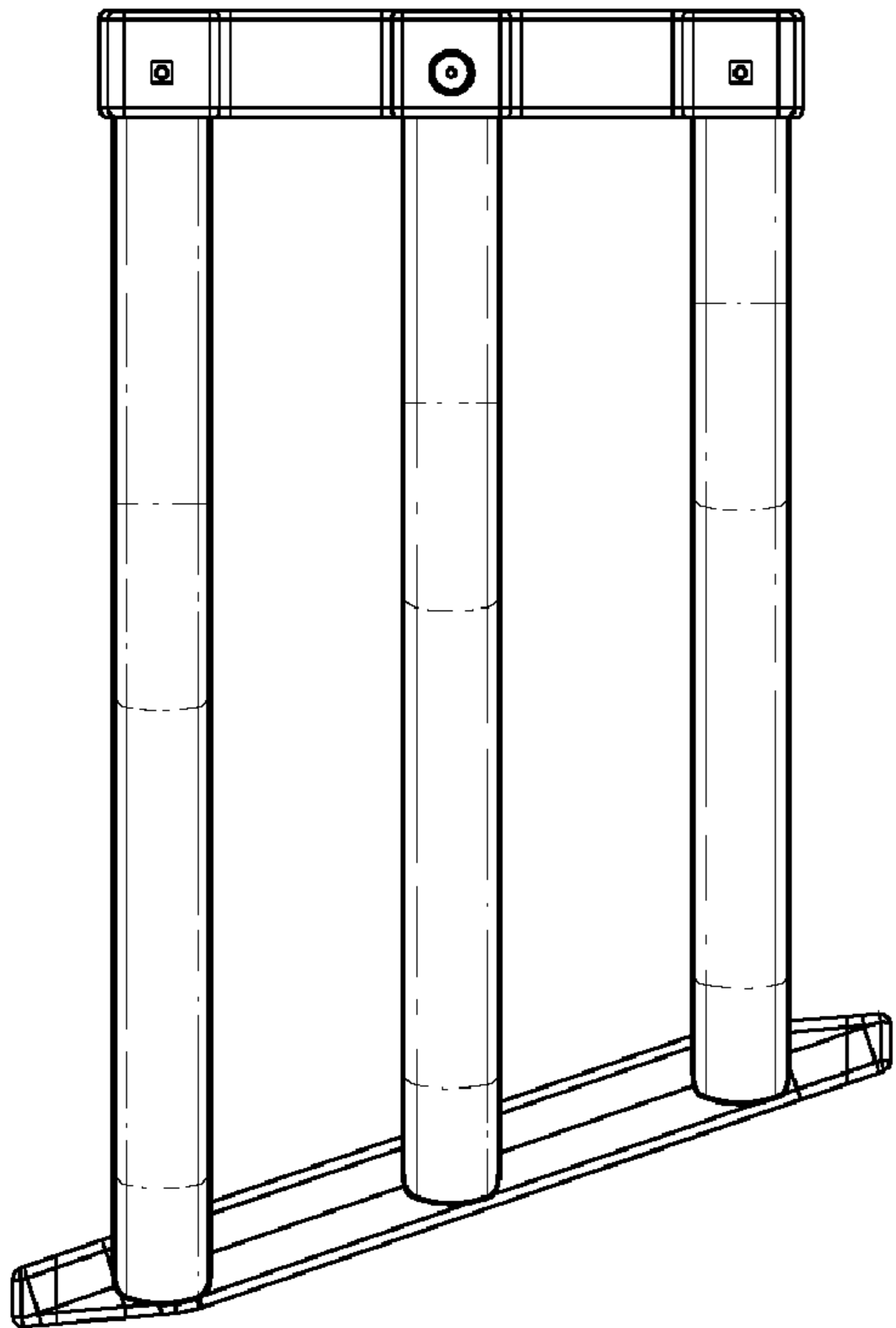

FIG. 7

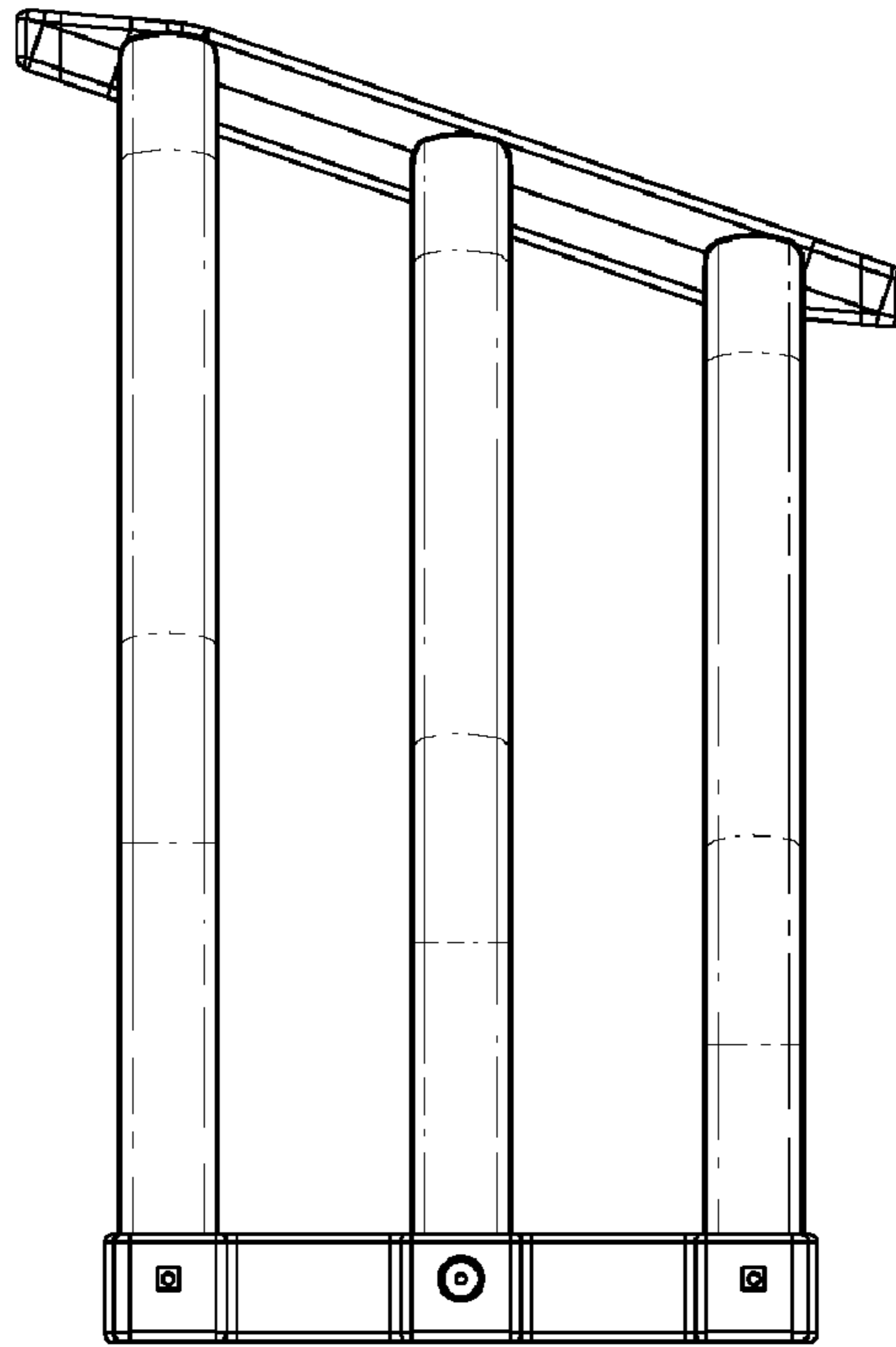

FIG. 8