



US00D553061S

(12) **United States Design Patent**  
**Schmidt et al.**

(10) **Patent No.:** **US D553,061 S**

(45) **Date of Patent:** **\*\* Oct. 16, 2007**

(54) **VEHICULAR MIRROR**

(75) Inventors: **William P. Schmidt**, Newport, MI (US); **Daniel M. Swain**, Wyandotte, MI (US)

(73) Assignee: **Mirror Lite**, Rockwood, MI (US)

(\*\*) Term: **14 Years**

(21) Appl. No.: **29/275,560**

(22) Filed: **Dec. 29, 2006**

**Related U.S. Application Data**

(63) Continuation of application No. 10/908,038, filed on Apr. 26, 2005, which is a continuation-in-part of application No. 10/708,123, filed on Feb. 10, 2004, now Pat. No. 7,134,759.

(51) **LOC (8) Cl.** ..... **12-16**

(52) **U.S. Cl.** ..... **D12/187**

(58) **Field of Classification Search** ..... D12/187-189;  
359/838-851, 855-868, 871-881, 603-604;  
248/475.1, 476, 479-484, 485-487; 350/629,  
350/632

See application file for complete search history.

(56) **References Cited**

**U.S. PATENT DOCUMENTS**

2,911,177	A *	11/1959	West	.....	248/484
3,063,344	A *	11/1962	Slate	.....	359/871
D214,619	S *	7/1969	Vitaioni	.....	D12/187
D234,760	S *	4/1975	Tanaka	.....	D12/187
D293,903	S *	1/1988	Kolenda et al.	.....	D12/187
4,822,157	A *	4/1989	Stout	.....	359/868
4,938,578	A *	7/1990	Schmidt et al.	.....	359/868

D320,591	S *	10/1991	Schmidt et al.	.....	D12/187
5,084,785	A *	1/1992	Albers et al.	.....	359/868
D346,356	S *	4/1994	Leu	.....	D12/187
D346,357	S *	4/1994	Englander	.....	D12/189
D401,200	S *	11/1998	Huang	.....	D12/187
D431,508	S *	10/2000	Matsumoto et al.	.....	D12/187
6,293,679	B1 *	9/2001	Schmidt et al.	.....	359/603
D456,330	S *	4/2002	Wade	.....	D12/187
D486,106	S *	2/2004	Huang	.....	D12/187
D499,678	S *	12/2004	Bradley	.....	D12/187
7,012,761	B1 *	3/2006	Schmidt et al.	.....	359/708
D528,484	S *	9/2006	Schmidt et al.	.....	D12/187

\* cited by examiner

*Primary Examiner*—Stacia Cadmus

(74) *Attorney, Agent, or Firm*—John A. Artz; DickinsonWright PLLC

(57) **CLAIM**

The ornamental design for the vehicular mirror, as shown and described.

**DESCRIPTION**

FIG. 1 is a perspective view of the vehicular mirror;

FIG. 2 is a front view of the vehicular mirror;

FIG. 3 is a rear view of the vehicular mirror;

FIG. 4 is a top view of the vehicular mirror;

FIG. 5 is a bottom view of the vehicular mirror;

FIG. 6 is a left side view of the vehicular mirror; and,

FIG. 7 is a right side view of the vehicular mirror.

Broken lines equal environment and not part of claimed design.

**1 Claim, 2 Drawing Sheets**

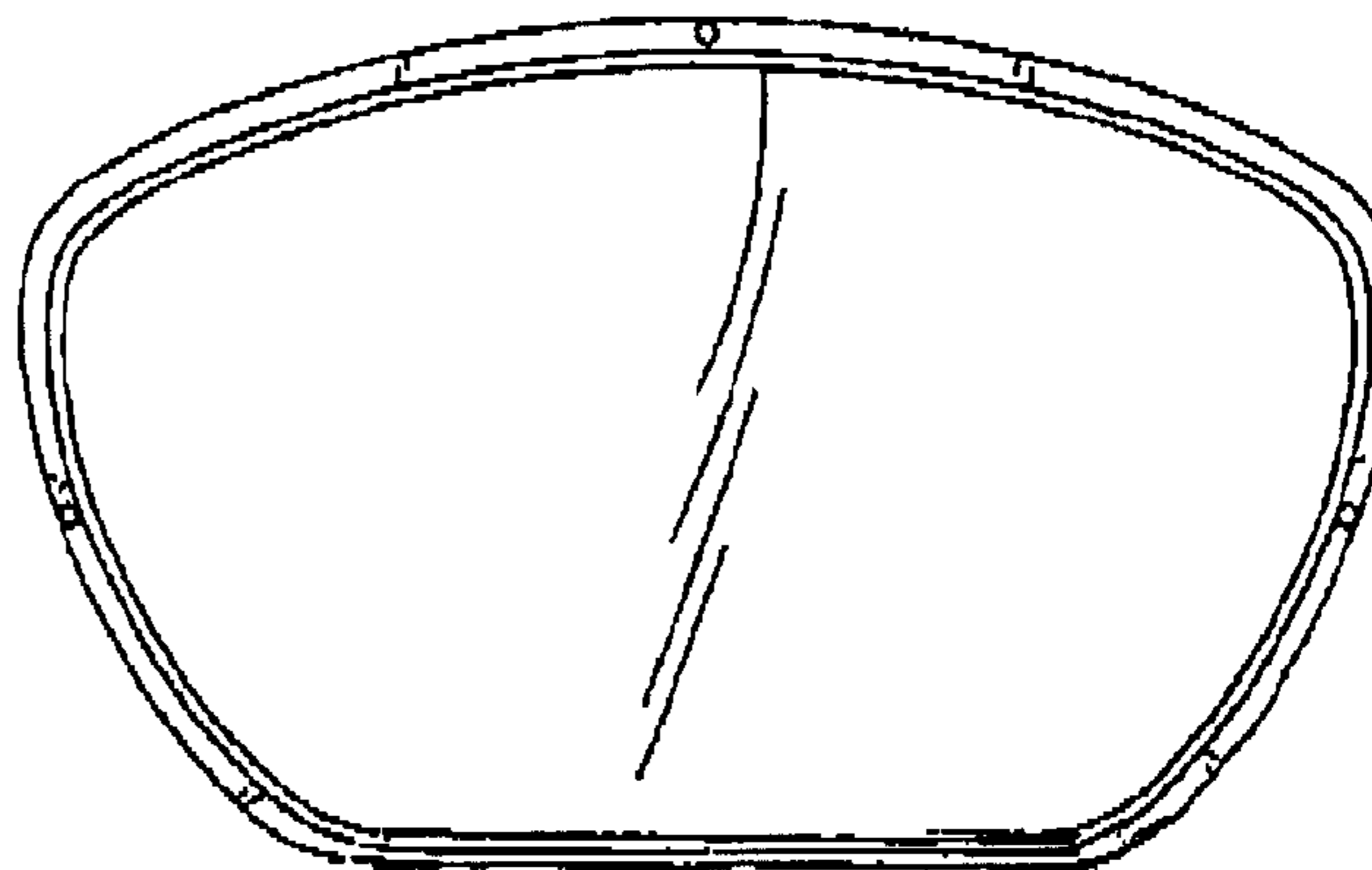
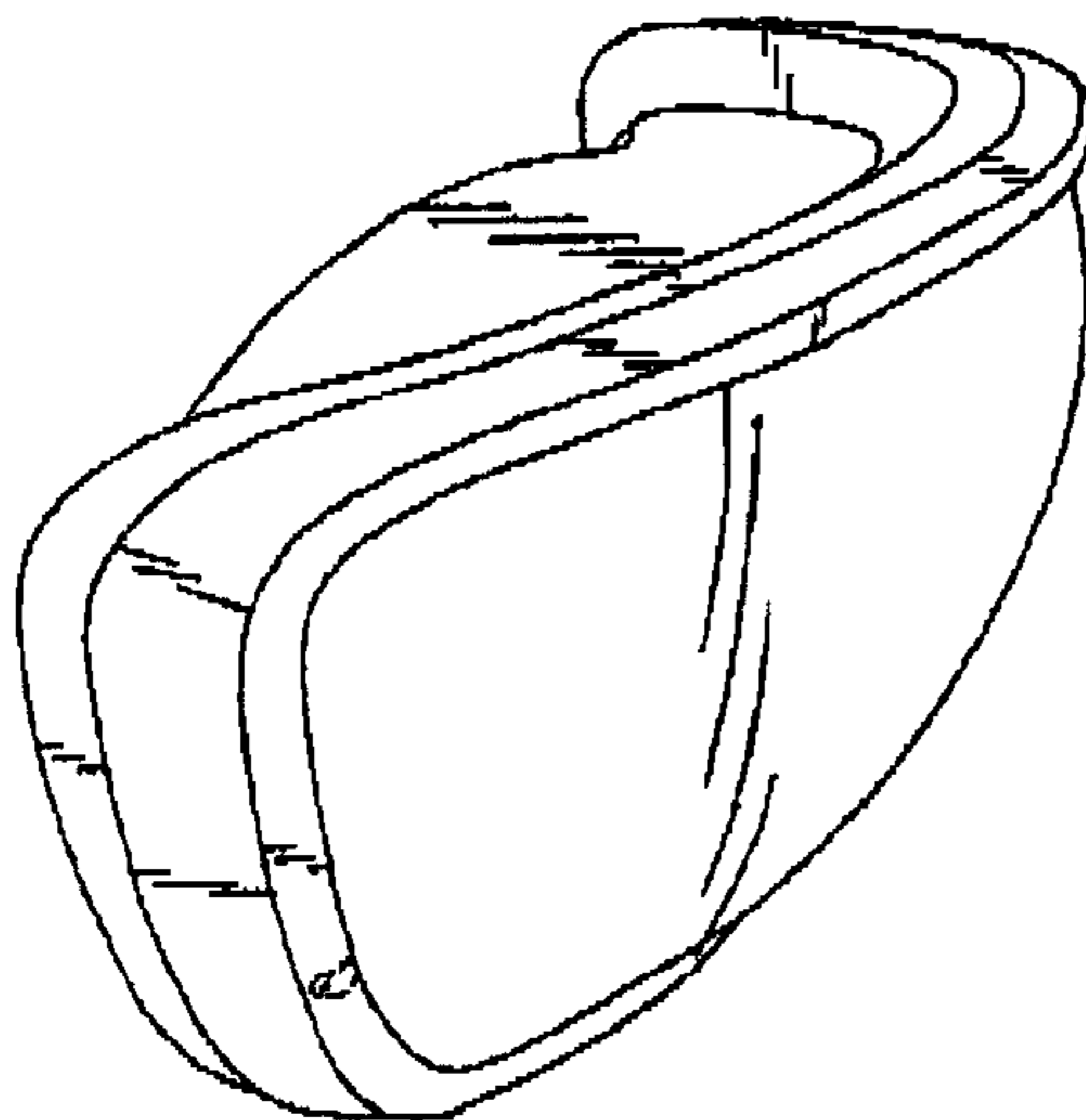

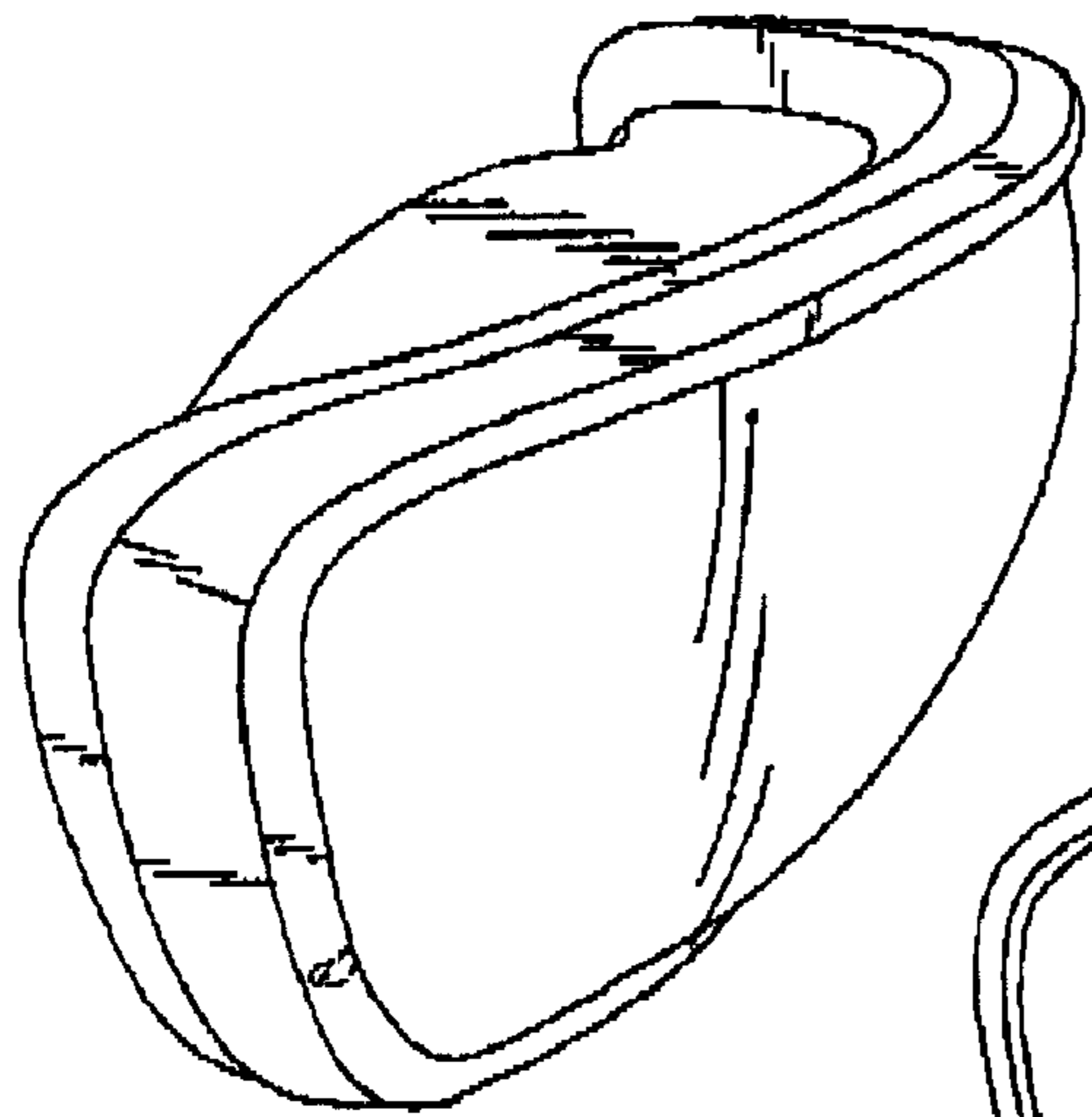

FIG. 1

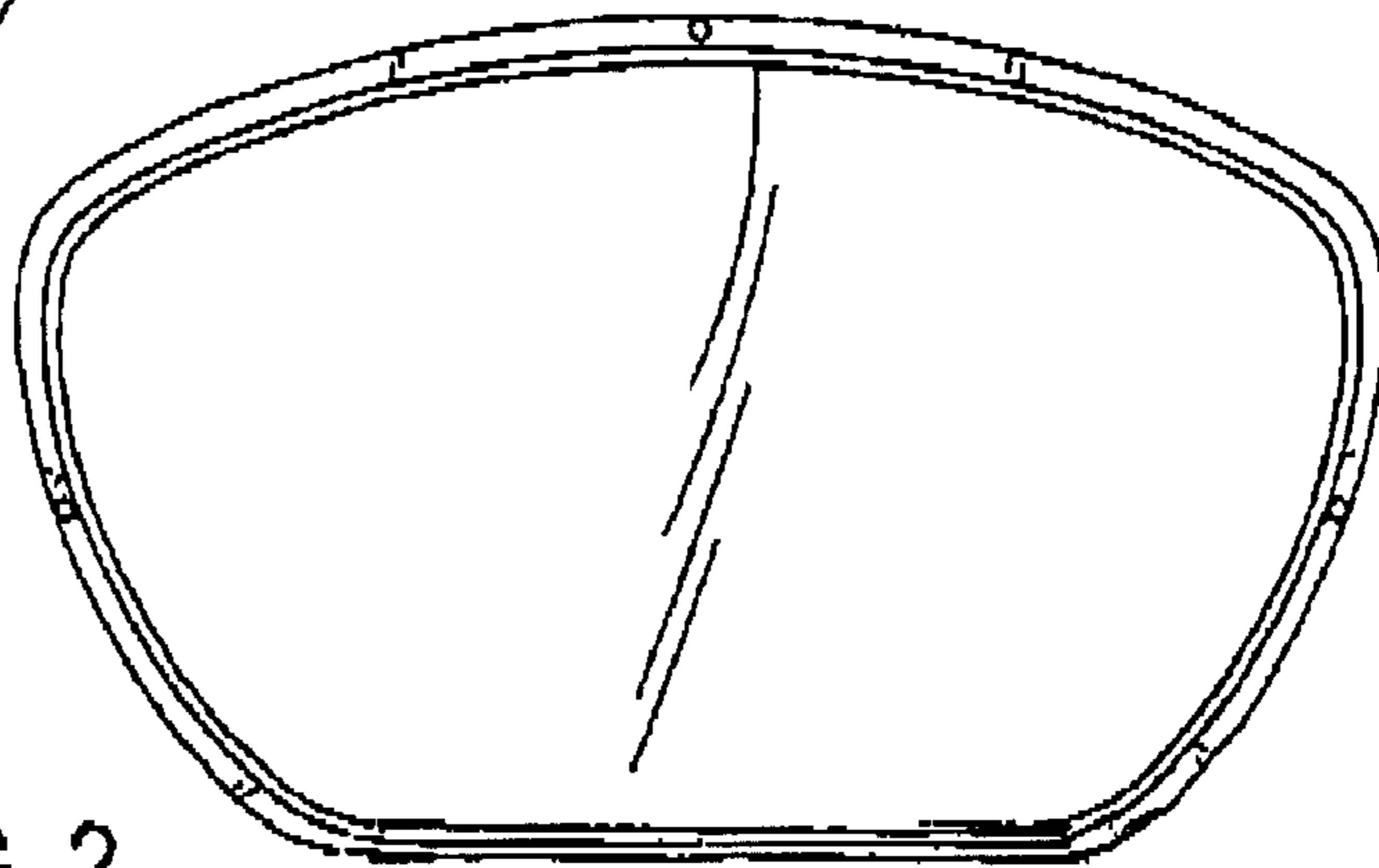

FIG. 2

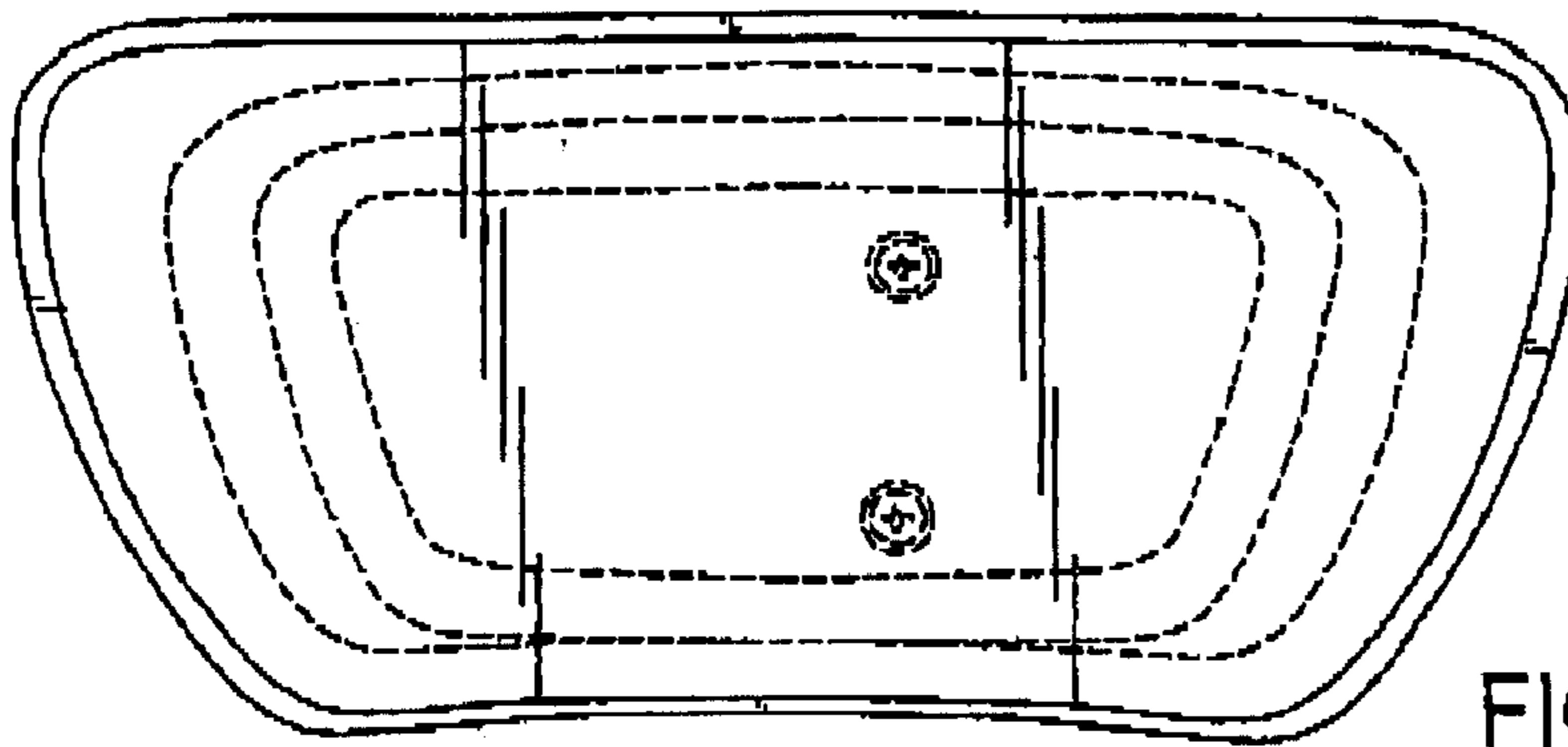

FIG. 3

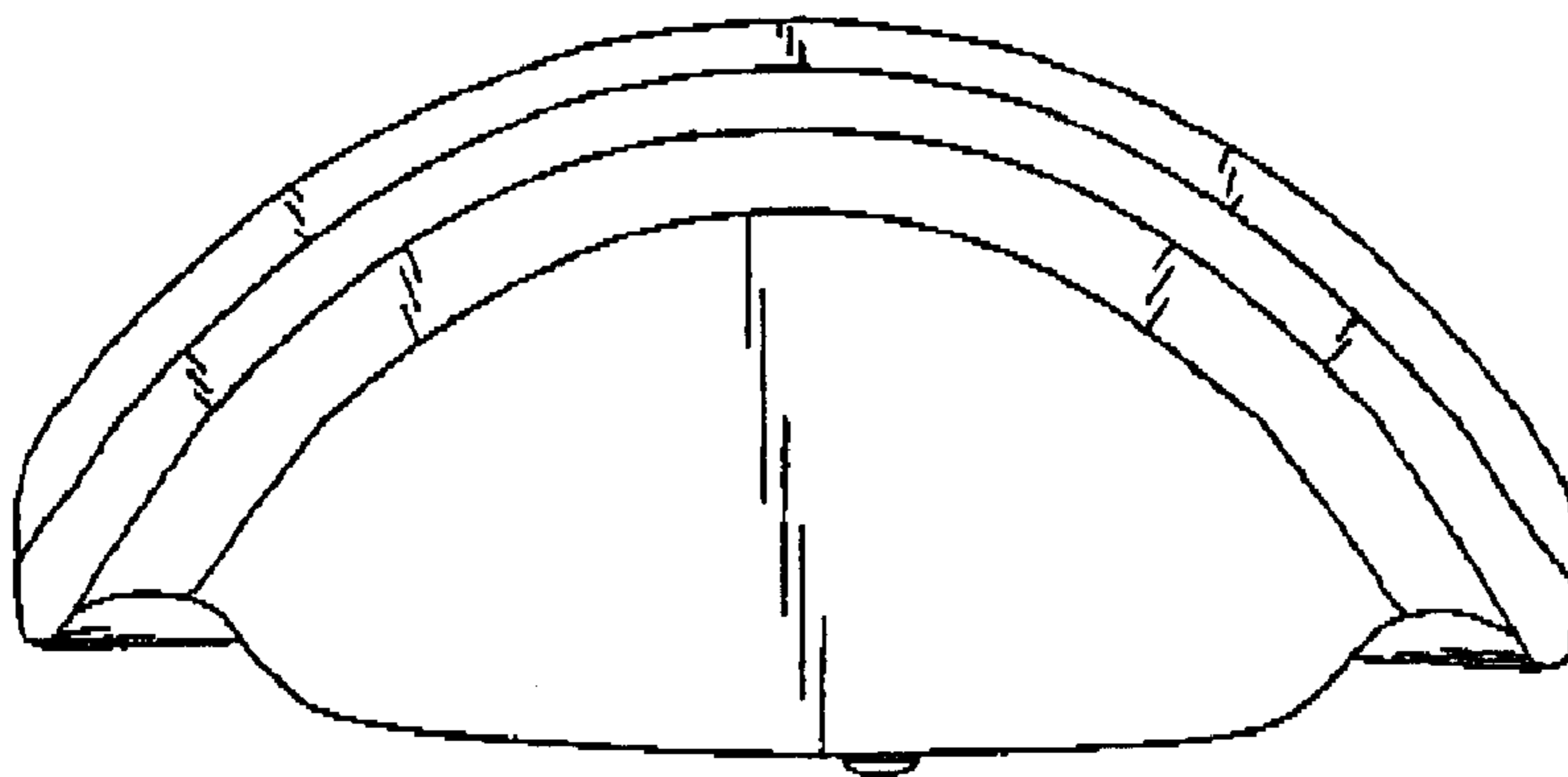

FIG. 4

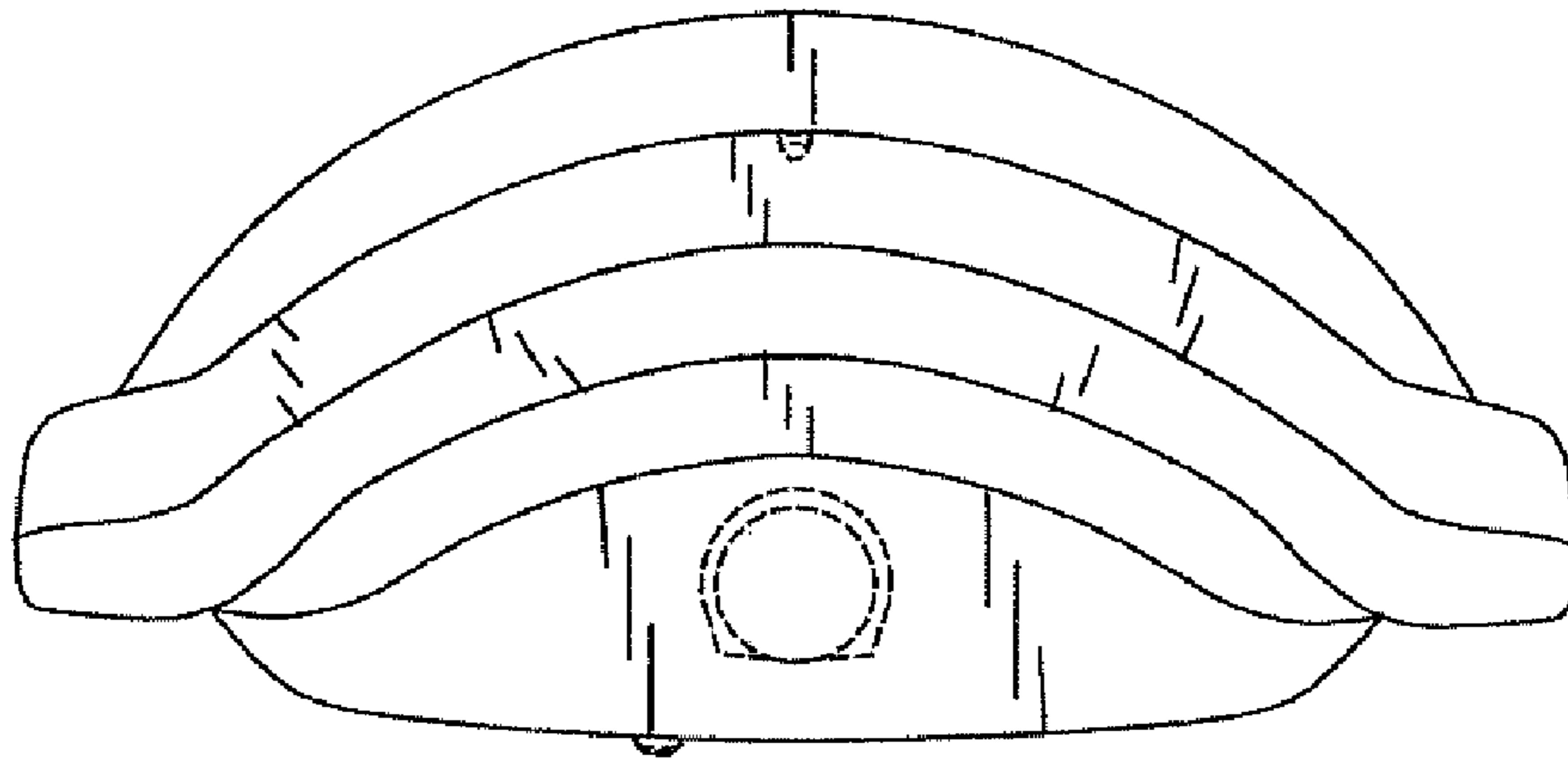

FIG. 5

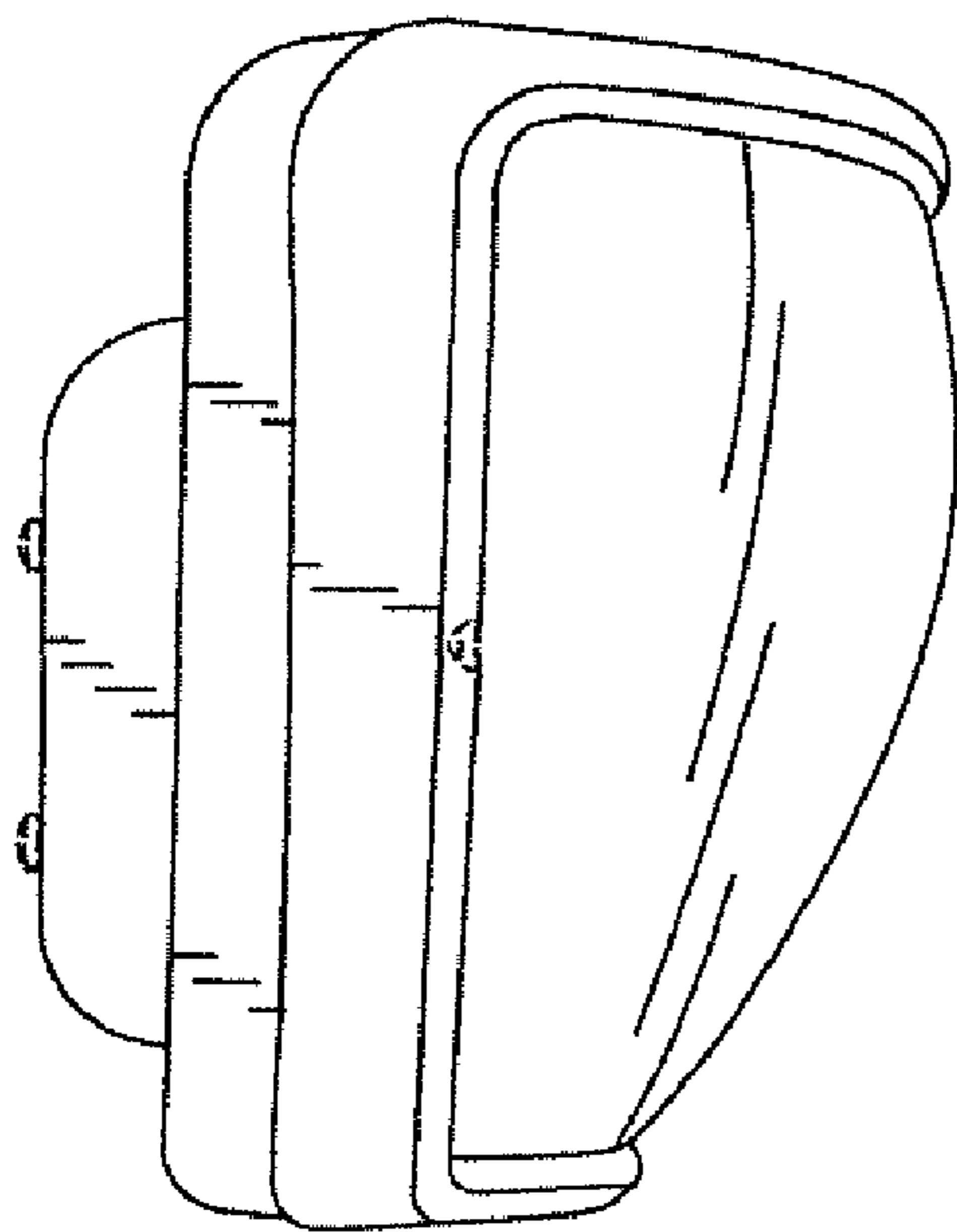

FIG. 6

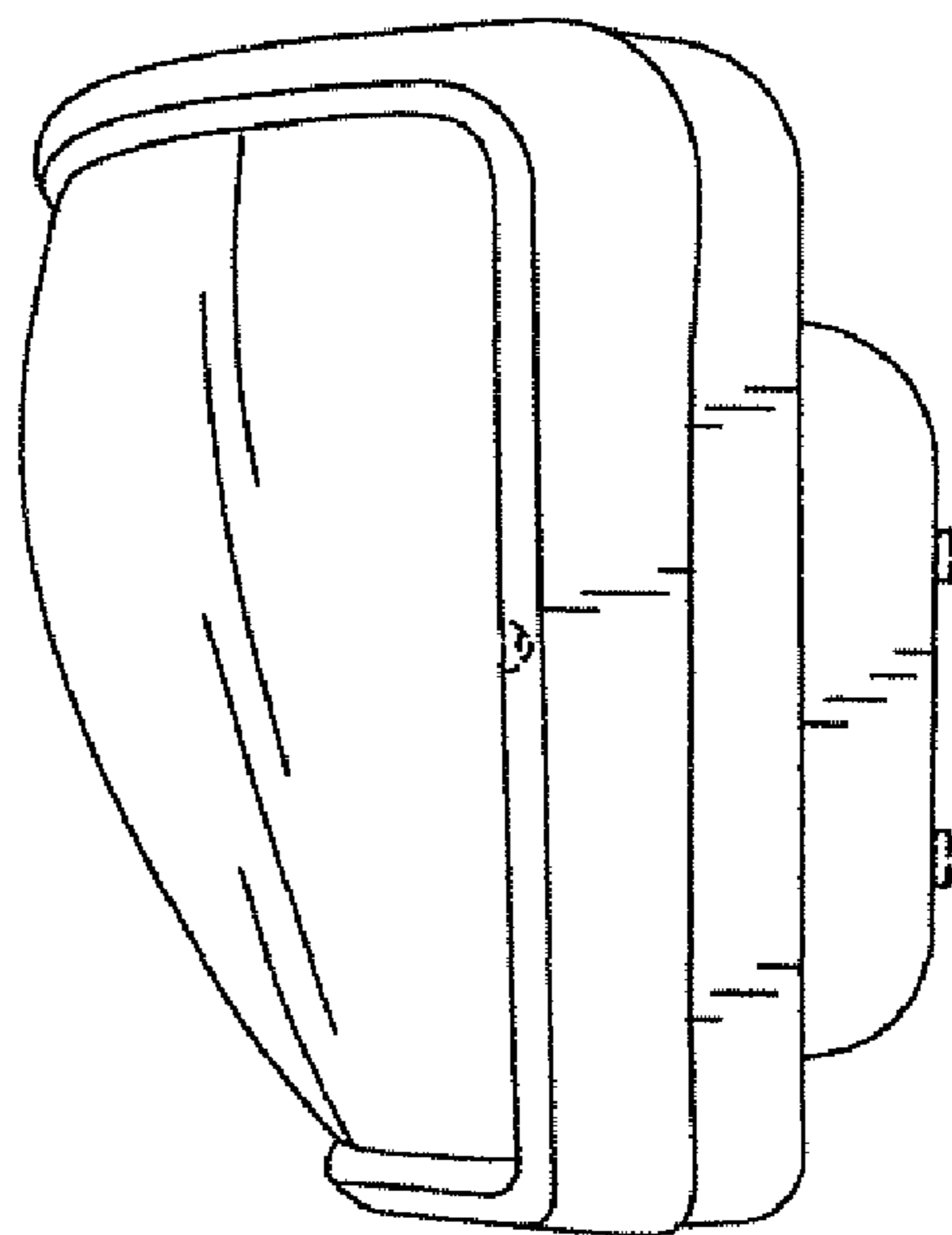

FIG. 7