



US00D553053S

(12) **United States Design Patent**
McChesney et al.

(10) **Patent No.:** **US D553,053 S**

(45) **Date of Patent:** **** Oct. 16, 2007**

(54) **AUTOMOTIVE EXTERIOR**

(57) **CLAIM**

(75) Inventors: **Mark McChesney**, Saline, MI (US);
James Kuo, Farmington Hills, MI
(US); **Patrick Schiavone**, Birmingham,
MI (US); **Chelsia Lau**, Ann Arbor, MI
(US)

The ornamental design for an automotive exterior, as shown
and described.

(73) Assignee: **Ford Global Technologies, LLC**,
Dearborn, MI (US)

DESCRIPTION

(**) Term: **14 Years**

FIG. 1 is a front end/right side perspective view of a first
embodiment automotive exterior in accordance with the
present invention, wherein a front end/left side perspective
view is a mirror image thereof;

(21) Appl. No.: **29/225,430**

FIG. 2 is a right side perspective view of the automotive
exterior of FIG. 1, wherein a left side perspective view is a
mirror image thereof;

(22) Filed: **Mar. 15, 2005**

(51) **LOC (8) Cl.** **12-08**

FIG. 3 is a rear end/right side perspective view of the
automotive exterior of FIG. 1, wherein a rear end/left side
perspective view is a mirror image thereof;

(52) **U.S. Cl.** **D12/98**

(58) **Field of Classification Search** D12/98,
D12/93; 296/181.2, 181.3
See application file for complete search history.

FIG. 4 is a rear end perspective view of the automotive
exterior of FIG. 1;

(56) **References Cited**

U.S. PATENT DOCUMENTS

D500,461 S * 1/2005 Noguchi et al. D12/98
D508,440 S * 8/2005 Hall et al. D12/98
D537,385 S * 2/2007 Shimoguchi et al. D12/98

FIG. 5 is a front end/right side perspective view of a second
embodiment automotive exterior in accordance with the
present invention, wherein a front end/left side perspective
view is a mirror image thereof, wherein a rear end perspec-
tive view thereof is illustrated in FIG. 4;

OTHER PUBLICATIONS

<http://www.fordvehicles.com/suvs/explorersporttrac/>, Ford
Vehicles: 2005 Ford Explorer Sport Trac—See pricing details, SUV
options, packages and more, 16 pages.

FIG. 6 is a right side perspective view of the automotive
exterior of FIG. 5, wherein a left side perspective view is a
mirror image thereof; and,

* cited by examiner

FIG. 7 is a rear end/right side perspective view of the
automotive exterior of FIG. 5, wherein a rear end/left side
perspective view is a mirror image thereof.

Primary Examiner—Melody N. Brown
(74) *Attorney, Agent, or Firm*—Frank A. MacKenzie;
Brooks Kushman P.C.

The broken lines are for illustrative purposes only and form
no part of the claimed design.

1 Claim, 7 Drawing Sheets

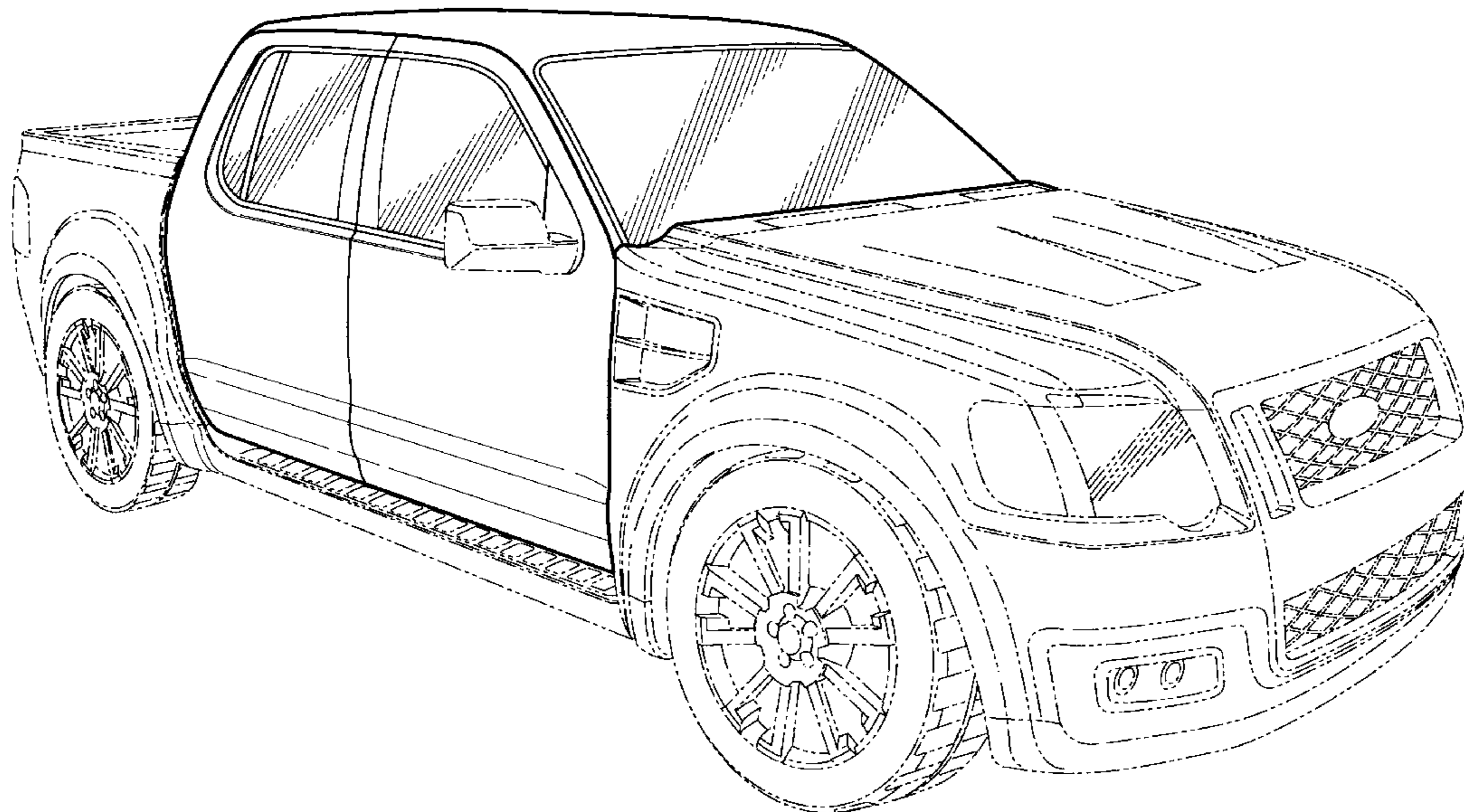

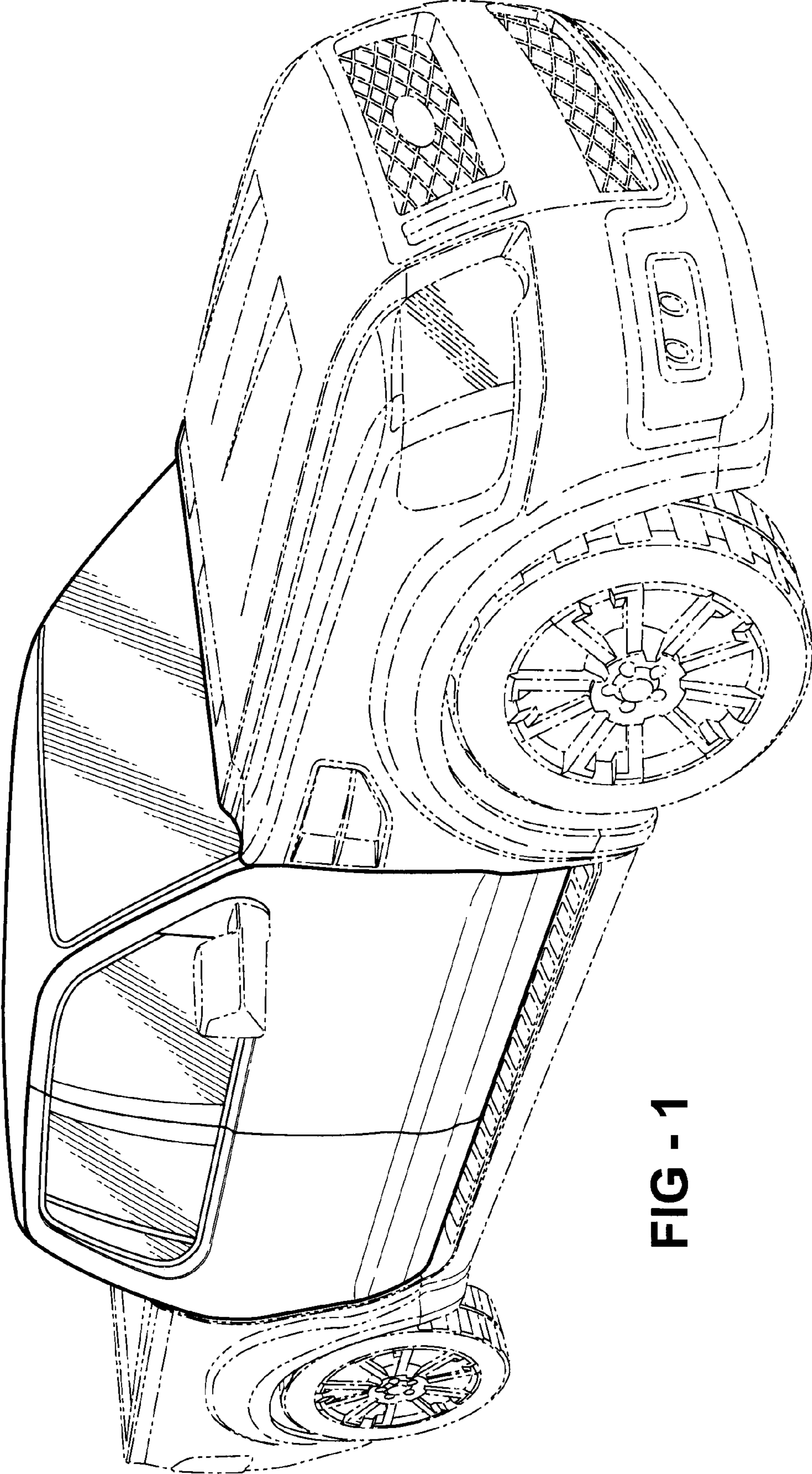

FIG - 1

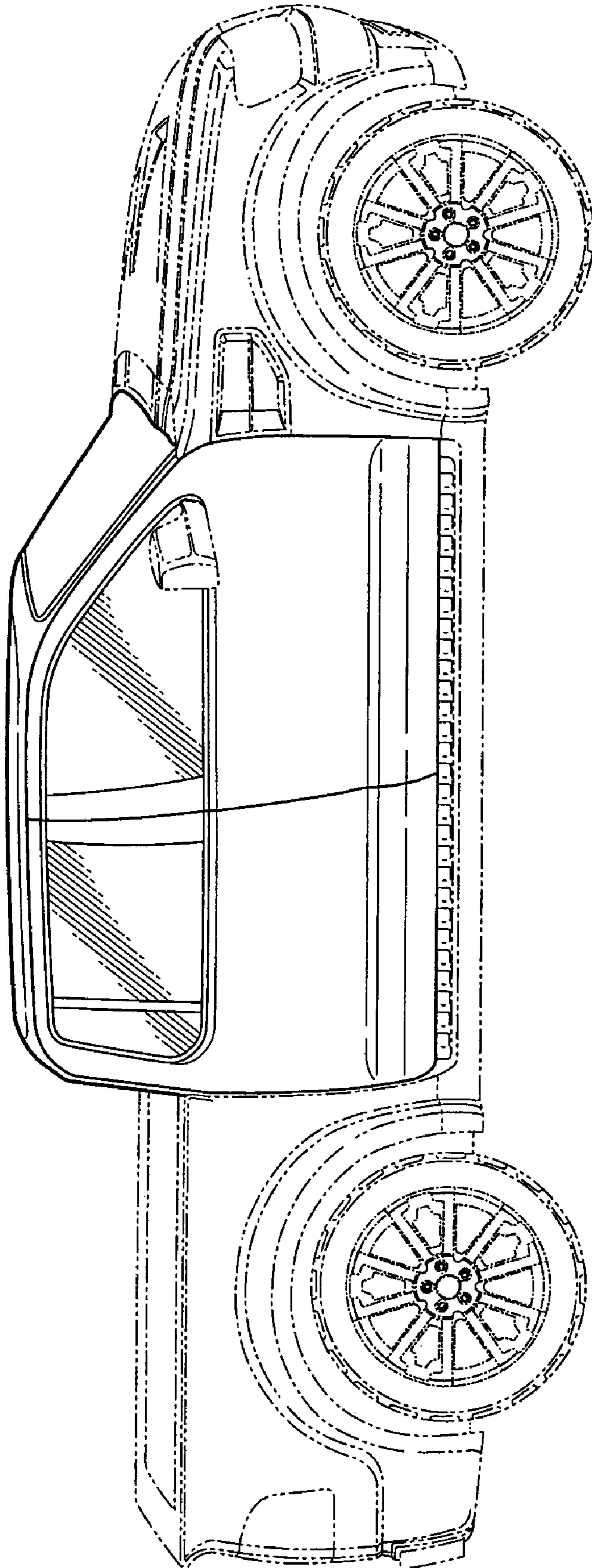

FIG - 2

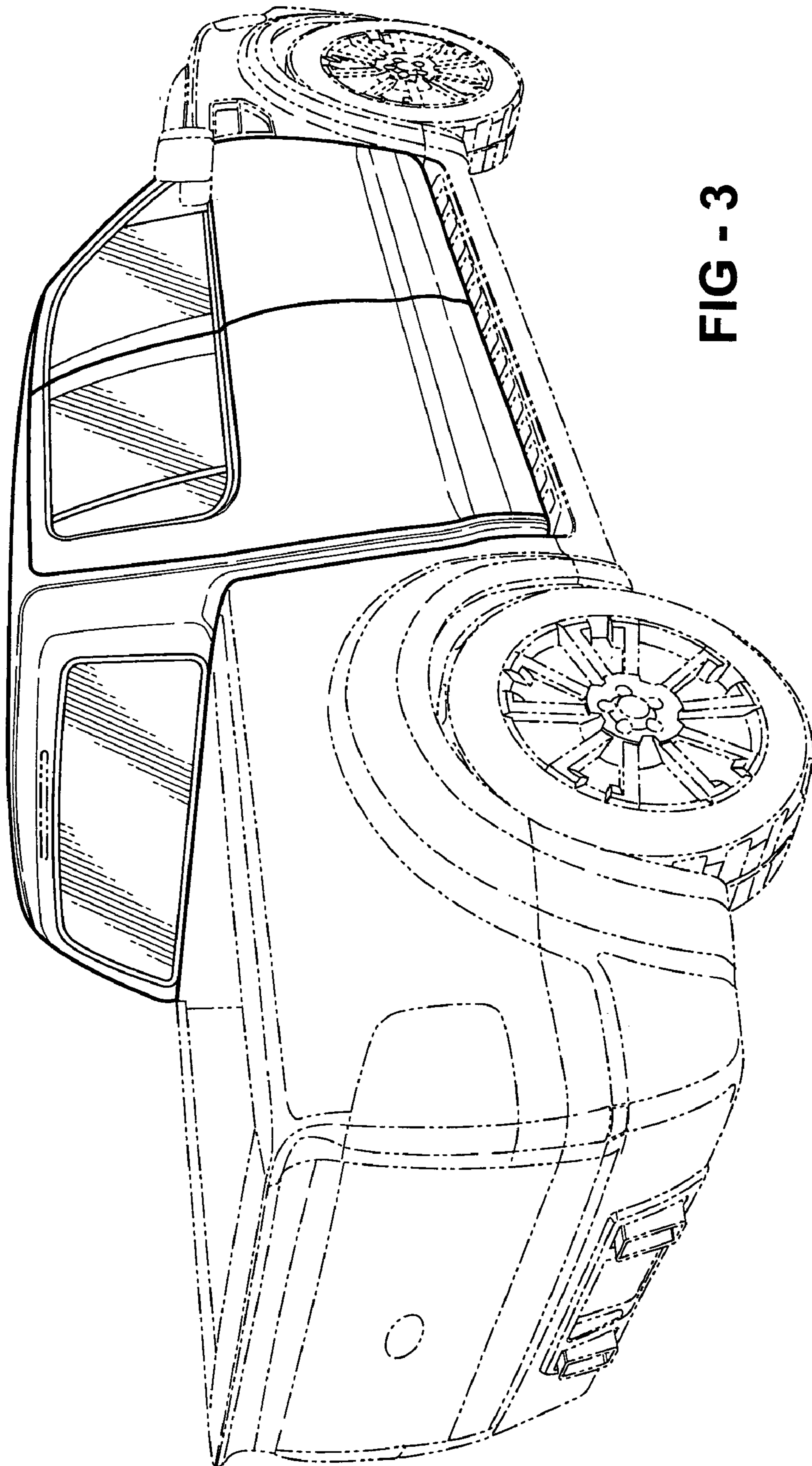

FIG - 3

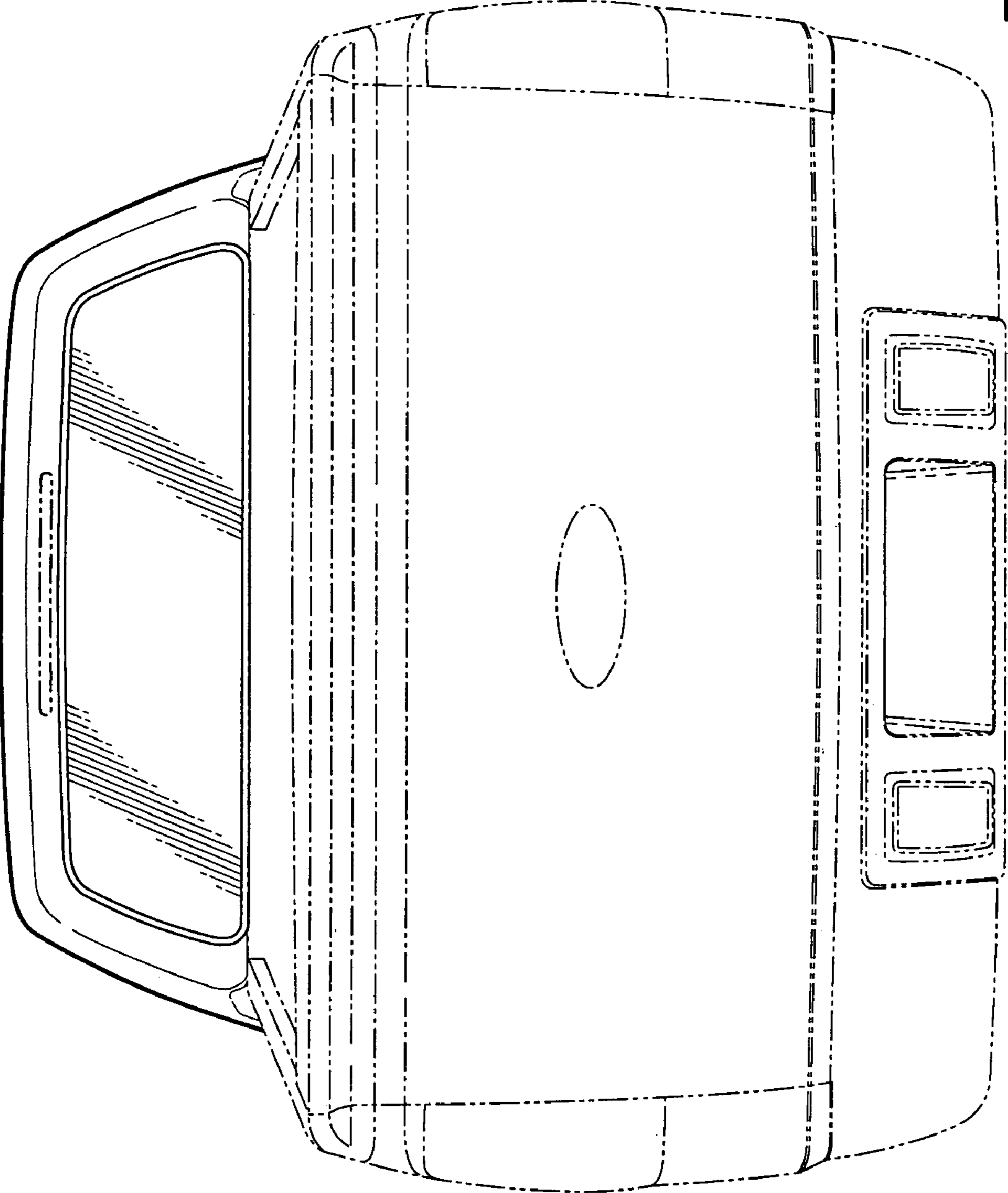

FIG - 4

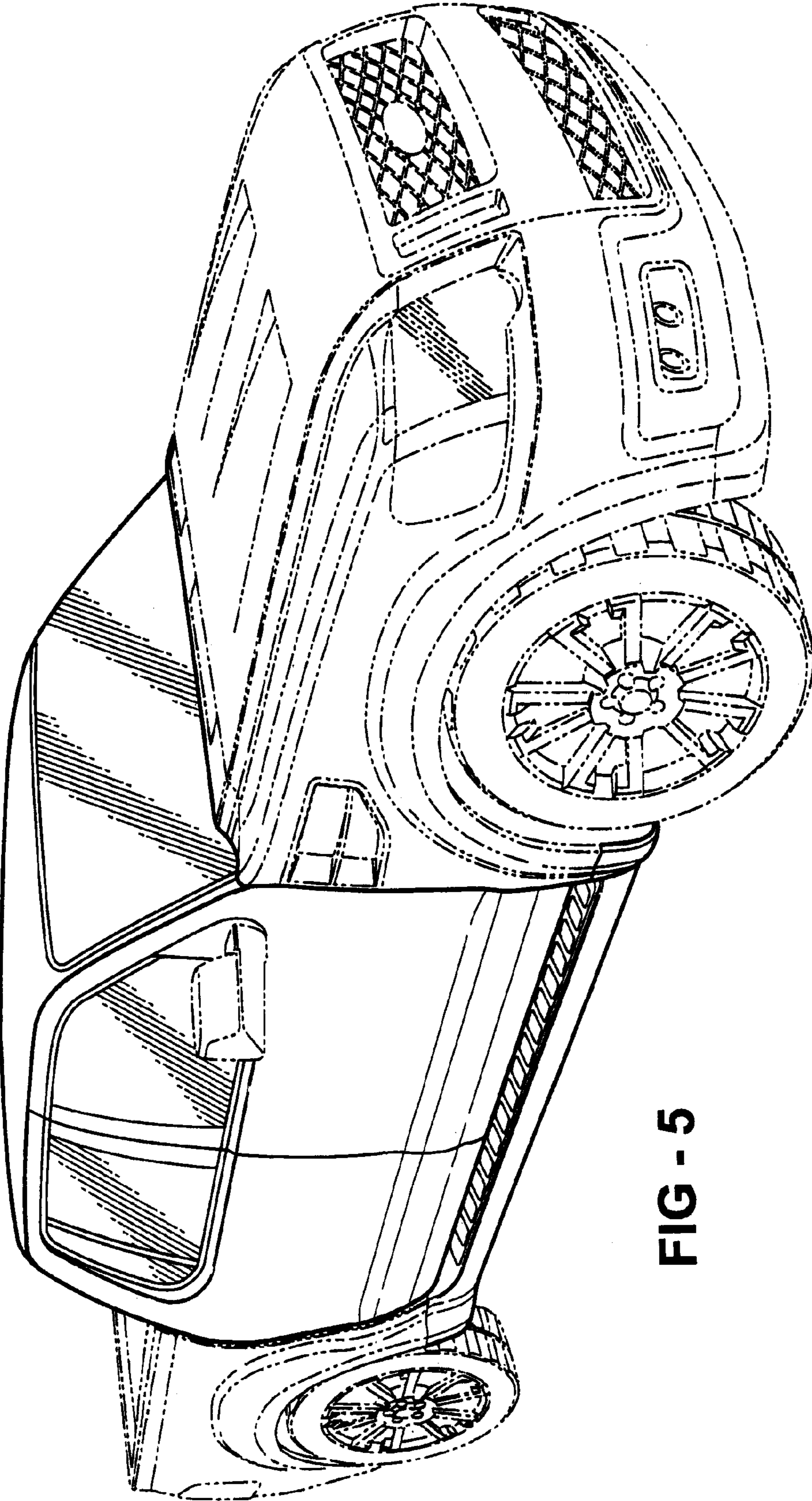

FIG - 5

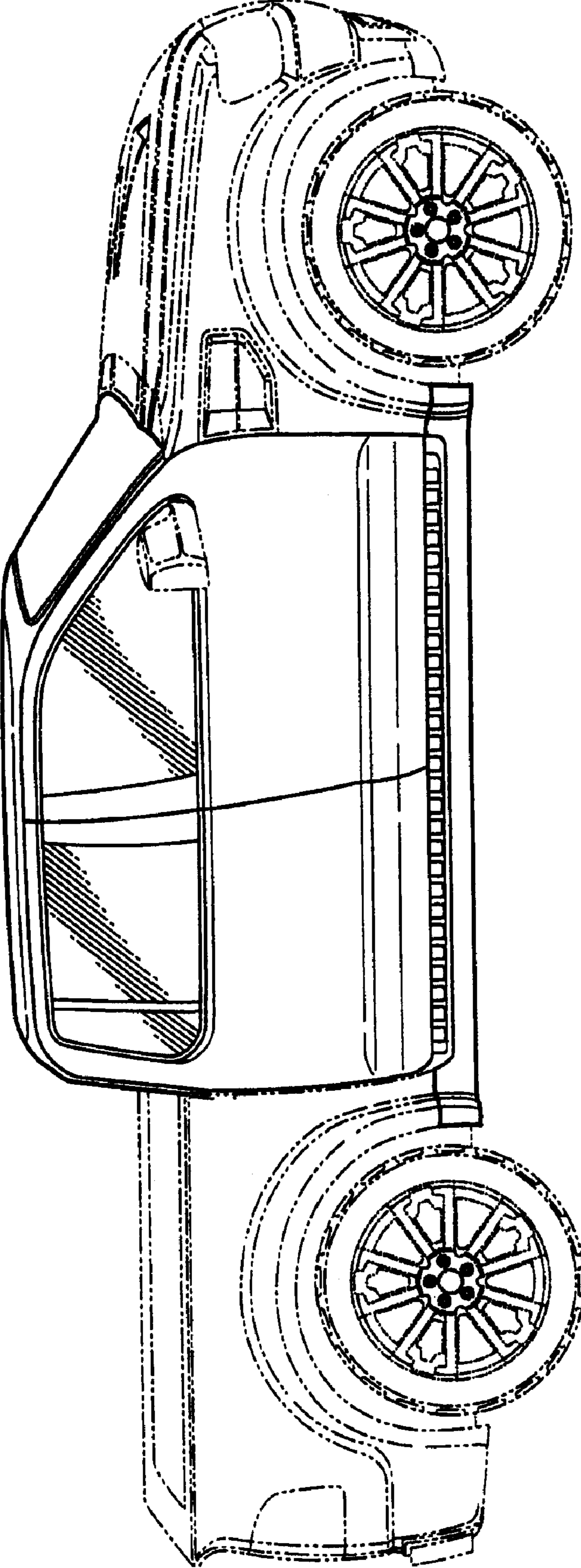

FIG - 6

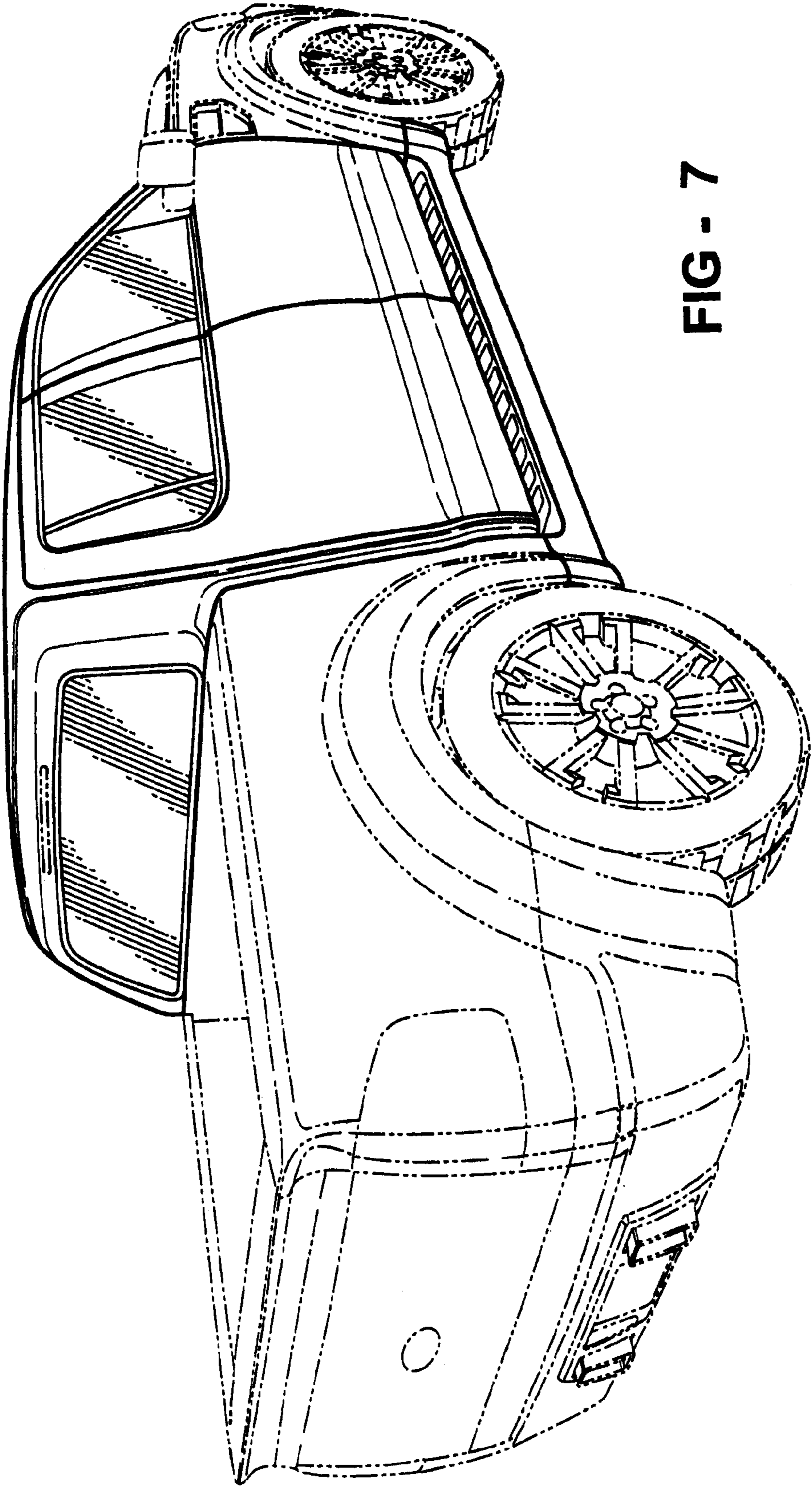

FIG - 7