



US00D552769S

(12) **United States Design Patent**
Leclercq

(10) **Patent No.:** **US D552,769 S**

(45) **Date of Patent:** **** Oct. 9, 2007**

(54) **SURFACE CONFIGURATION OF A
TAILLIGHT FOR A VEHICLE**

Primary Examiner—Marcus A. Jackson
(74) *Attorney, Agent, or Firm*—Crowell & Moring LLP

(75) Inventor: **Pierre Leclercq**, Munich (DE)

(57) **CLAIM**

(73) Assignee: **Bayerische Motoren Werke
Aktiengesellschaft**, Munich (DE)

The ornamental design for a surface configuration of a taillight for a vehicle, as shown and described.

(**) Term: **14 Years**

DESCRIPTION

(21) Appl. No.: **29/270,231**

This application is related to the following co-pending application, of the inventor, filed on even date herewith: Application Ser. No. 29/270,222, entitled “Surface Configuration of a Vehicle, Toy, and/or Other Replicas”.

(22) Filed: **Dec. 19, 2006**

(30) **Foreign Application Priority Data**

Jun. 20, 2006 (DE) 40603283

FIG. 1 is a right perspective view a first embodiment of a surface configuration of a taillight for a vehicle according to my novel design;

(51) **LOC (8) Cl.** **26-06**

(52) **U.S. Cl.** **D26/28**

FIG. 2 is a left perspective view thereof; and

(58) **Field of Classification Search** D26/28–36;
362/459–468, 475–478, 485–487

FIG. 3 is a front view thereof.

See application file for complete search history.

FIG. 4 is a left perspective view a second embodiment of a surface configuration of a taillight for a vehicle according to my novel design;

(56) **References Cited**

U.S. PATENT DOCUMENTS

D523,976 S	*	6/2006	Pfeiffer et al.	D26/28
D528,680 S	*	9/2006	Oda	D26/28
D538,452 S	*	3/2007	Pfeiffer	D26/28
D539,450 S	*	3/2007	Pfeiffer	D26/28
D540,480 S	*	4/2007	Pfeiffer	D26/28

FIG. 5 is a right perspective view thereof; and,

FIG. 6 is a front view thereof.

The broken lines are for illustrative purposes only and form no part of the claimed design. Also enclosed is a set of photographs of an embodiment of the invention.

* cited by examiner

1 Claim, 2 Drawing Sheets

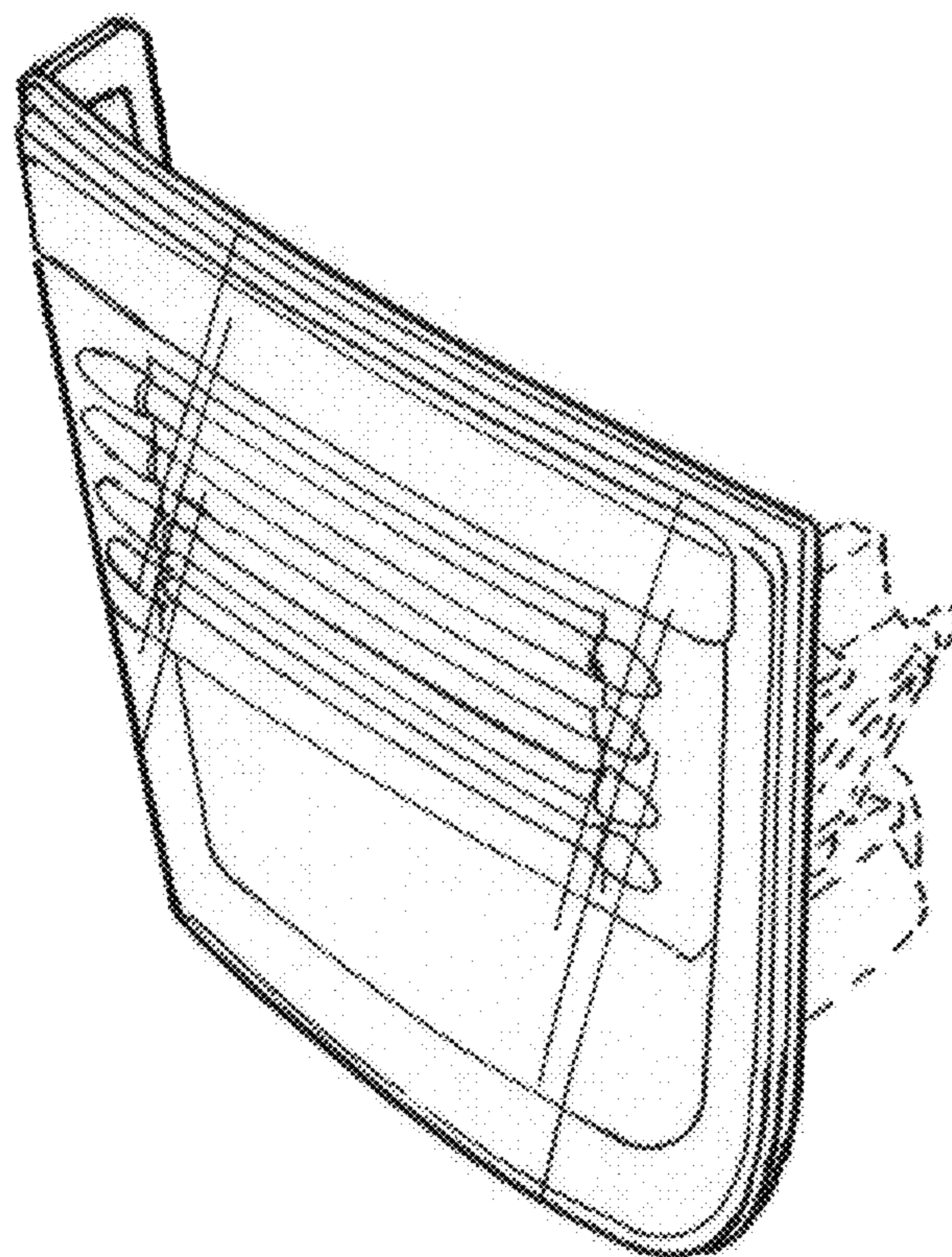

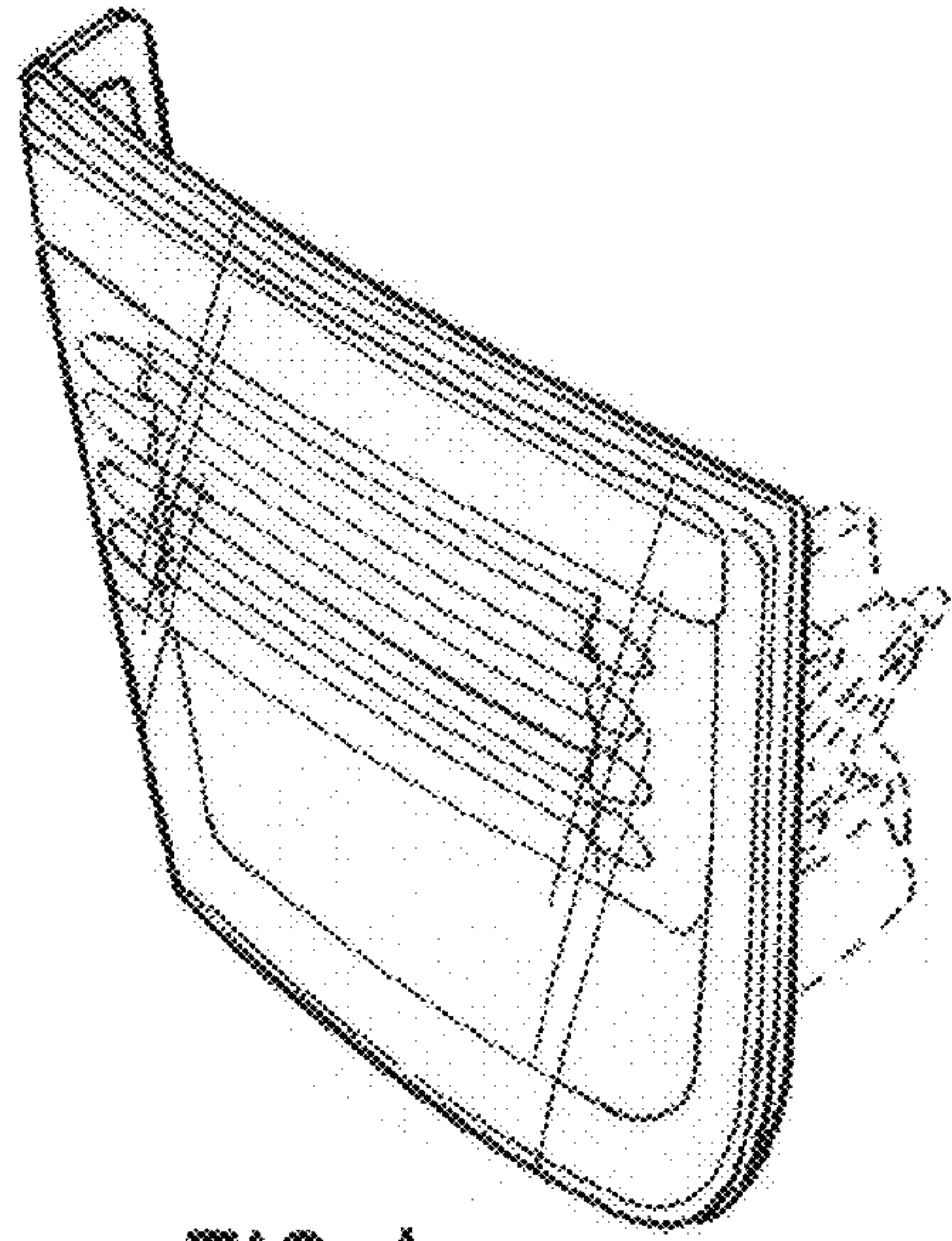

FIG. 1

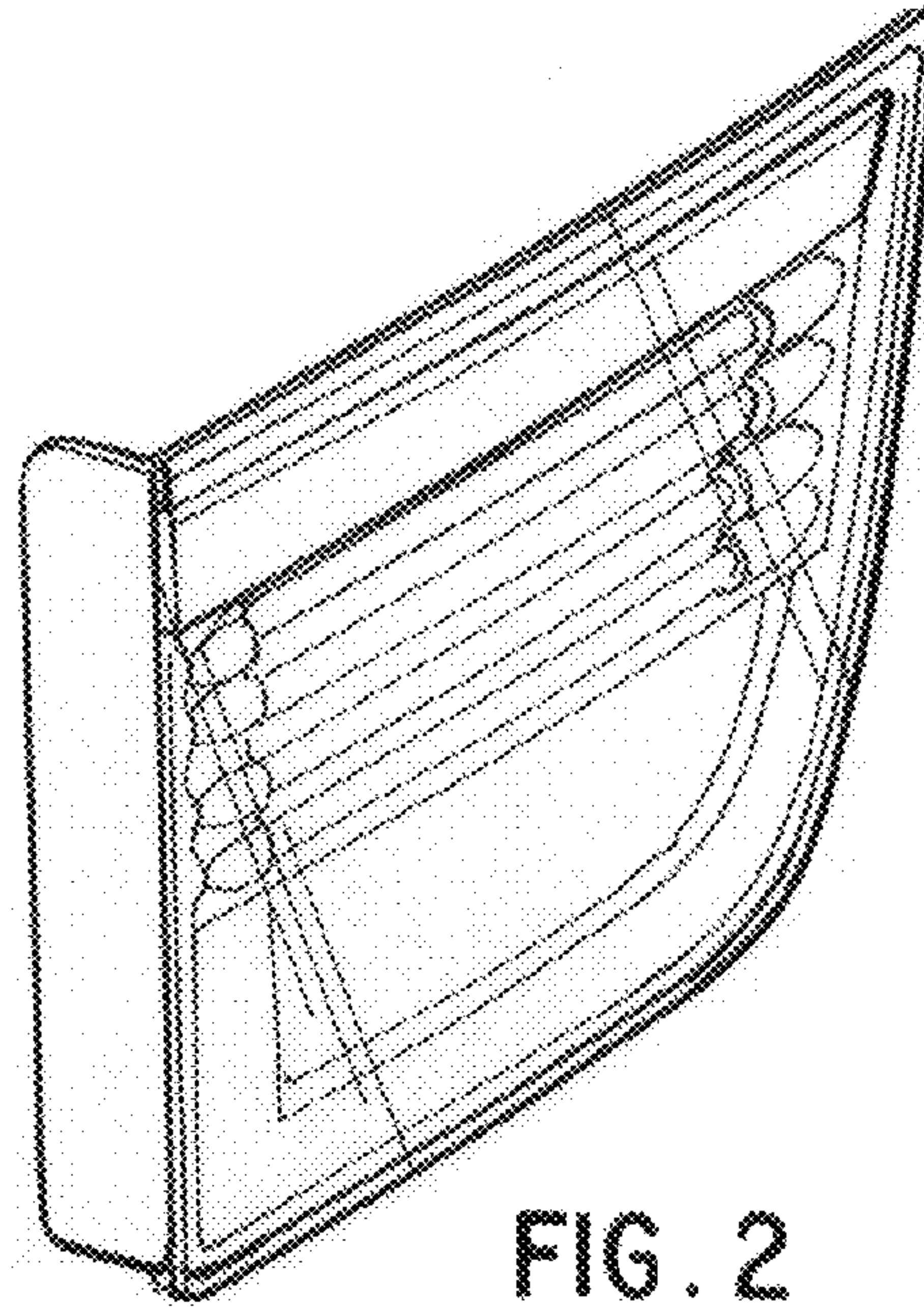

FIG. 2

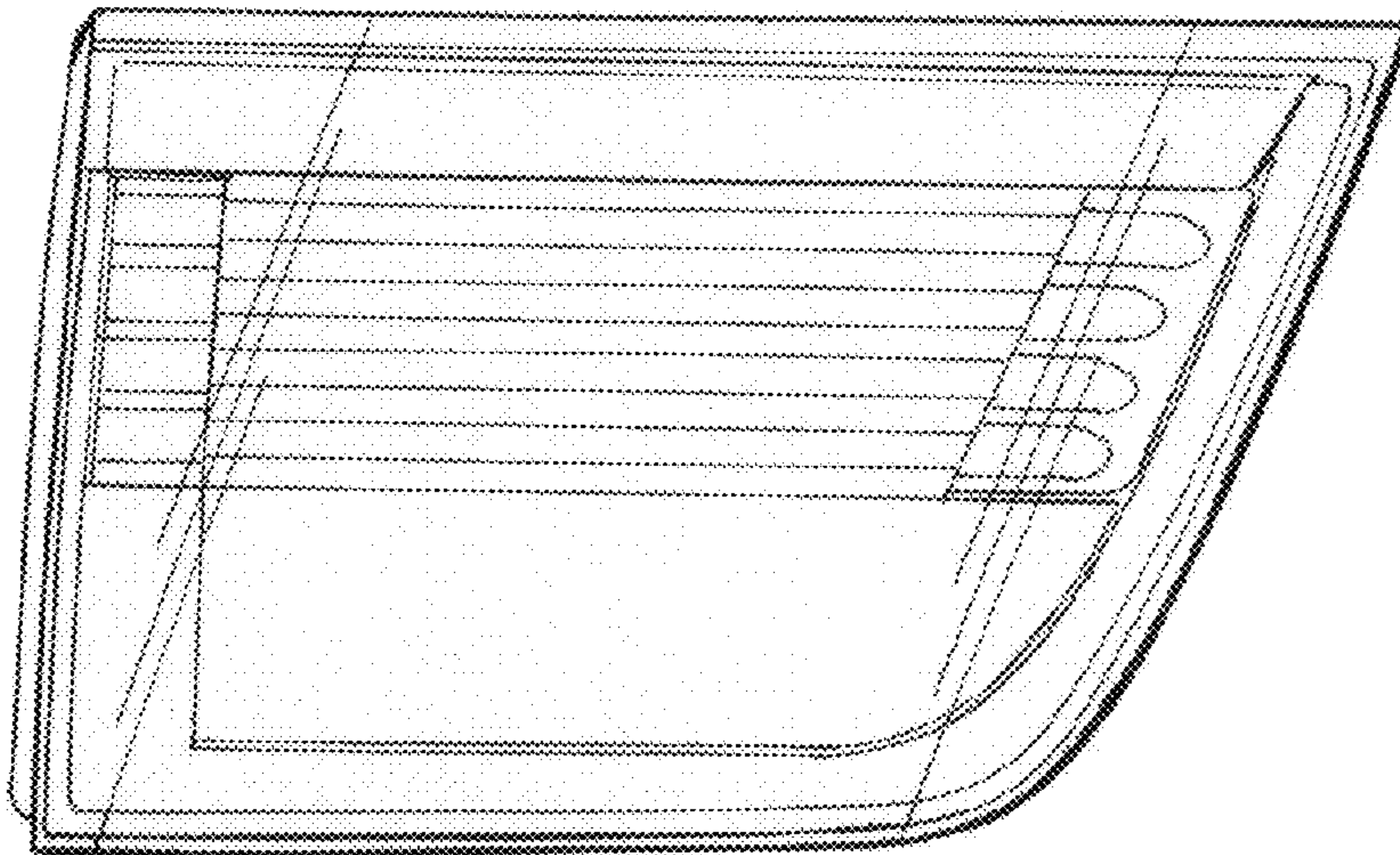

FIG. 3

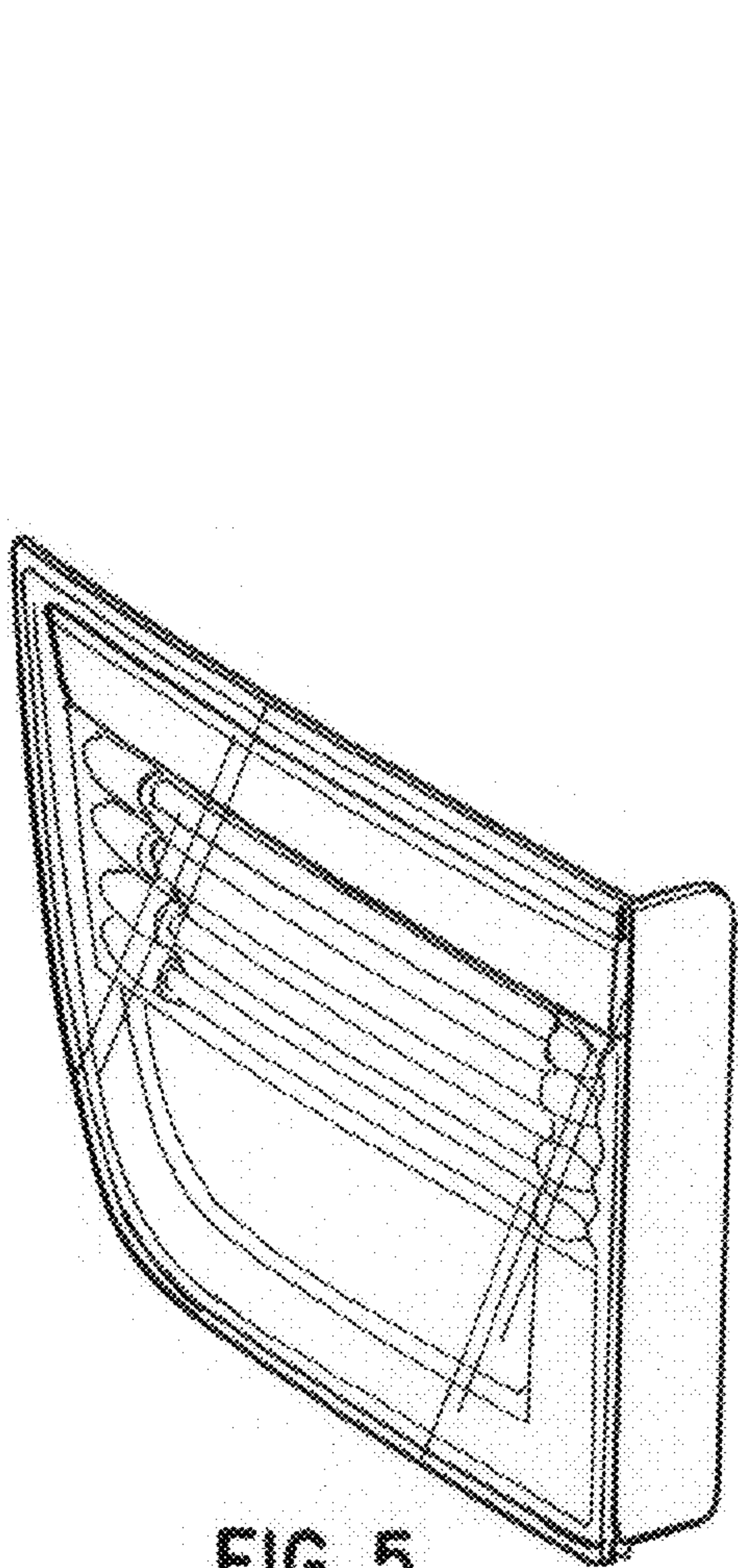

FIG. 5

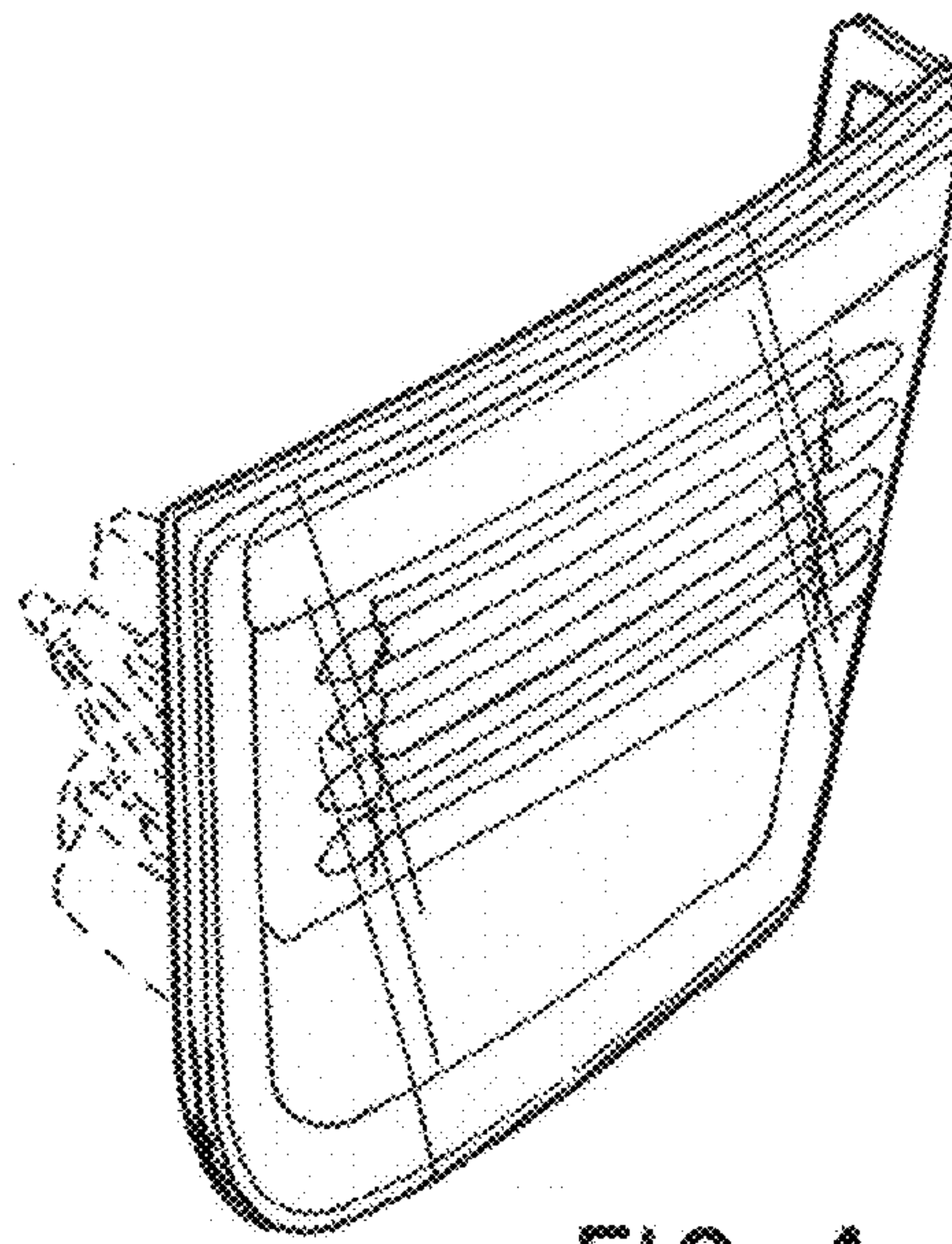

FIG. 4

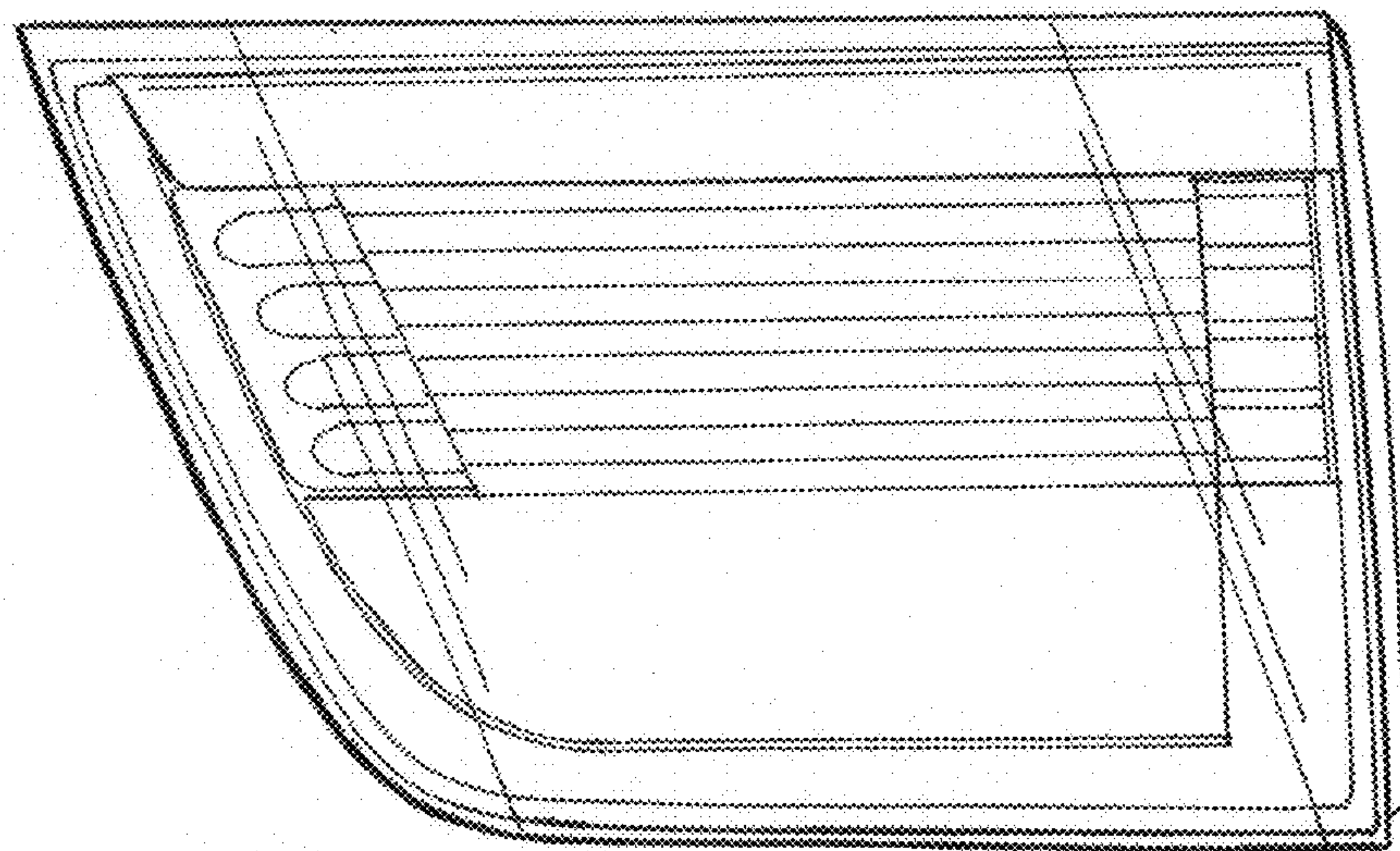

FIG. 6