



US00D552626S

(12) **United States Design Patent**
Suthmann

(10) **Patent No.:** **US D552,626 S**

(45) **Date of Patent:** **** Oct. 9, 2007**

(54) **COMPRESSOR UNIT**

D446,793 S * 8/2001 Matthew et al. D15/9

* cited by examiner

(75) Inventor: **Michael Suthmann**, Kranzberg (DE)

Primary Examiner—Ralf Seifert

(73) Assignee: **Kaeser Kompressoren GmbH**, Coburg (DE)

(74) *Attorney, Agent, or Firm*—Akerman Senterfitt; Jean C. Edwards, Esq.

(**) Term: **14 Years**

(57) **CLAIM**

(21) Appl. No.: **29/265,259**

The design for the compressor unit, as shown and described.

(22) Filed: **Aug. 29, 2006**

DESCRIPTION

(51) **LOC (8) Cl.** **15-02**

FIG. 1 is a perspective view of the front in one embodiment of my new design;

(52) **U.S. Cl.** **D15/9**

FIG. 2 is a front view thereof;

(58) **Field of Classification Search** D15/7-9;
D23/232, 231; 417/359, 414-416, 410.1,
417/321, 265, 405, 360

FIG. 3 is a rear view thereof;

FIG. 4 is a right side view thereof;

See application file for complete search history.

FIG. 5 is a left side view thereof;

FIG. 6 is a top view thereof; and,

FIG. 7 is a perspective view of the rear thereof.

It being understood that the broken lines are for illustrative purposes only and form no part of the claimed design.

(56) **References Cited**

U.S. PATENT DOCUMENTS

4,722,673 A * 2/1988 Grime et al. 417/360

D423,518 S * 4/2000 Milligan et al. D15/9

1 Claim, 7 Drawing Sheets

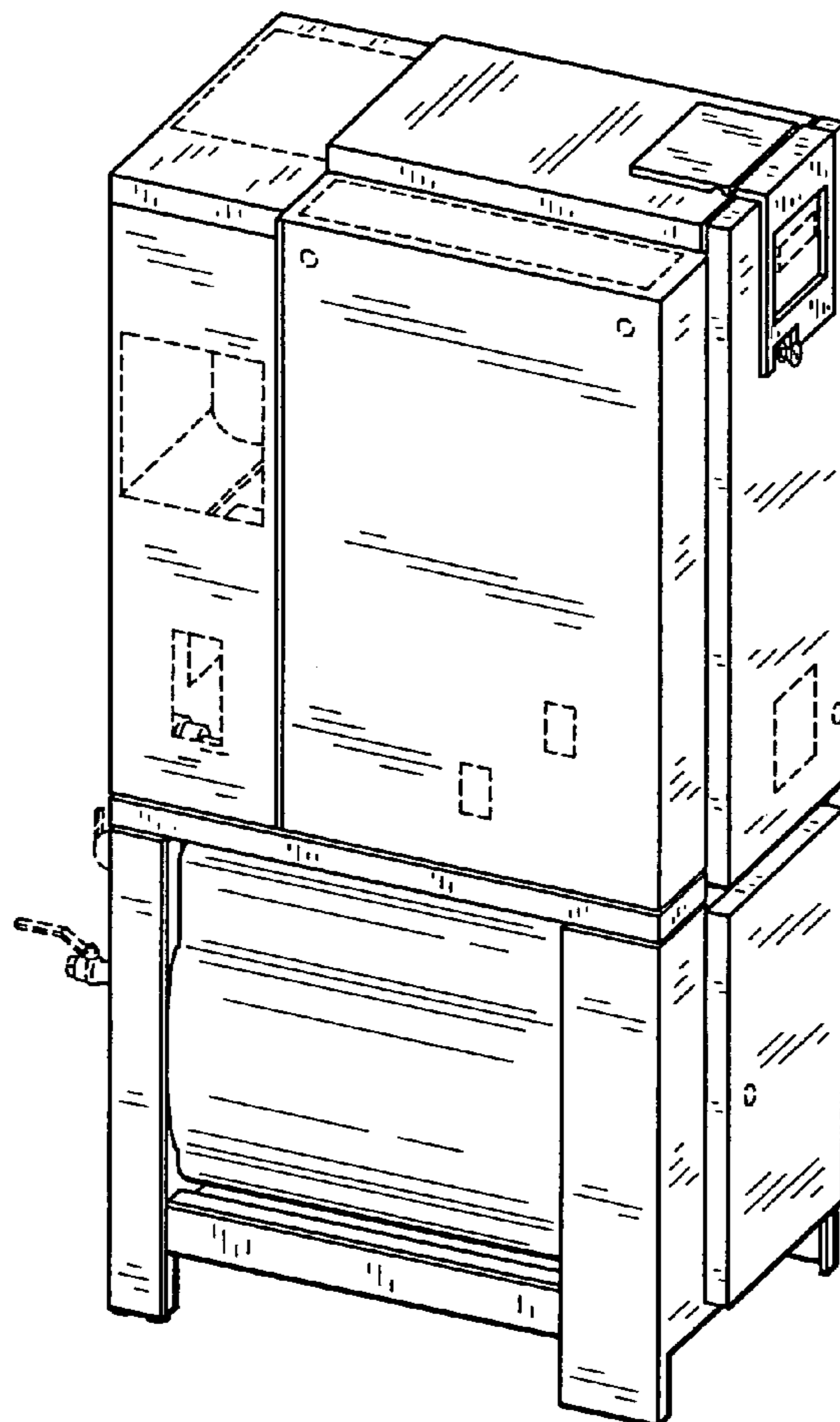

FIG. 1

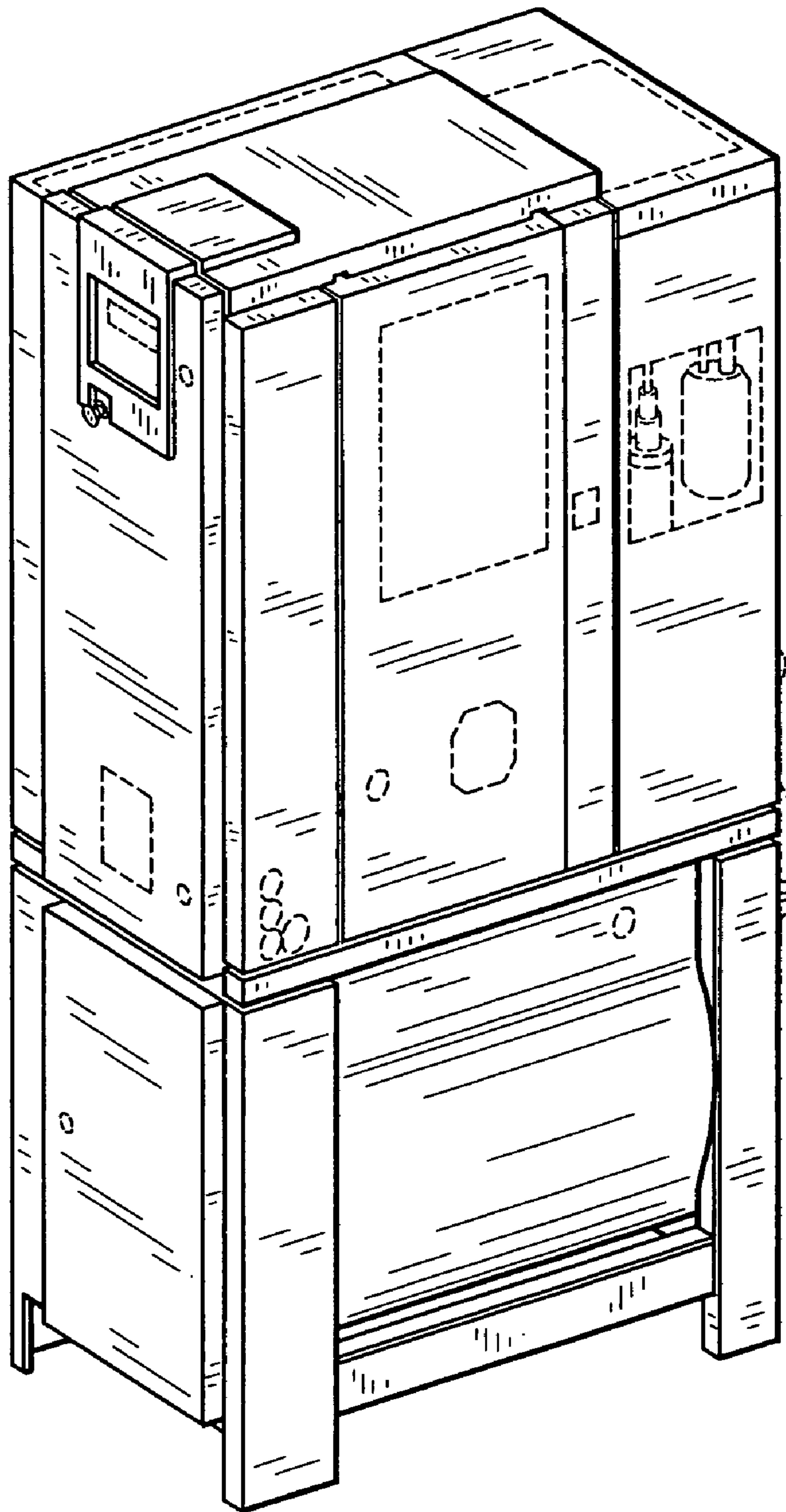

FIG. 2

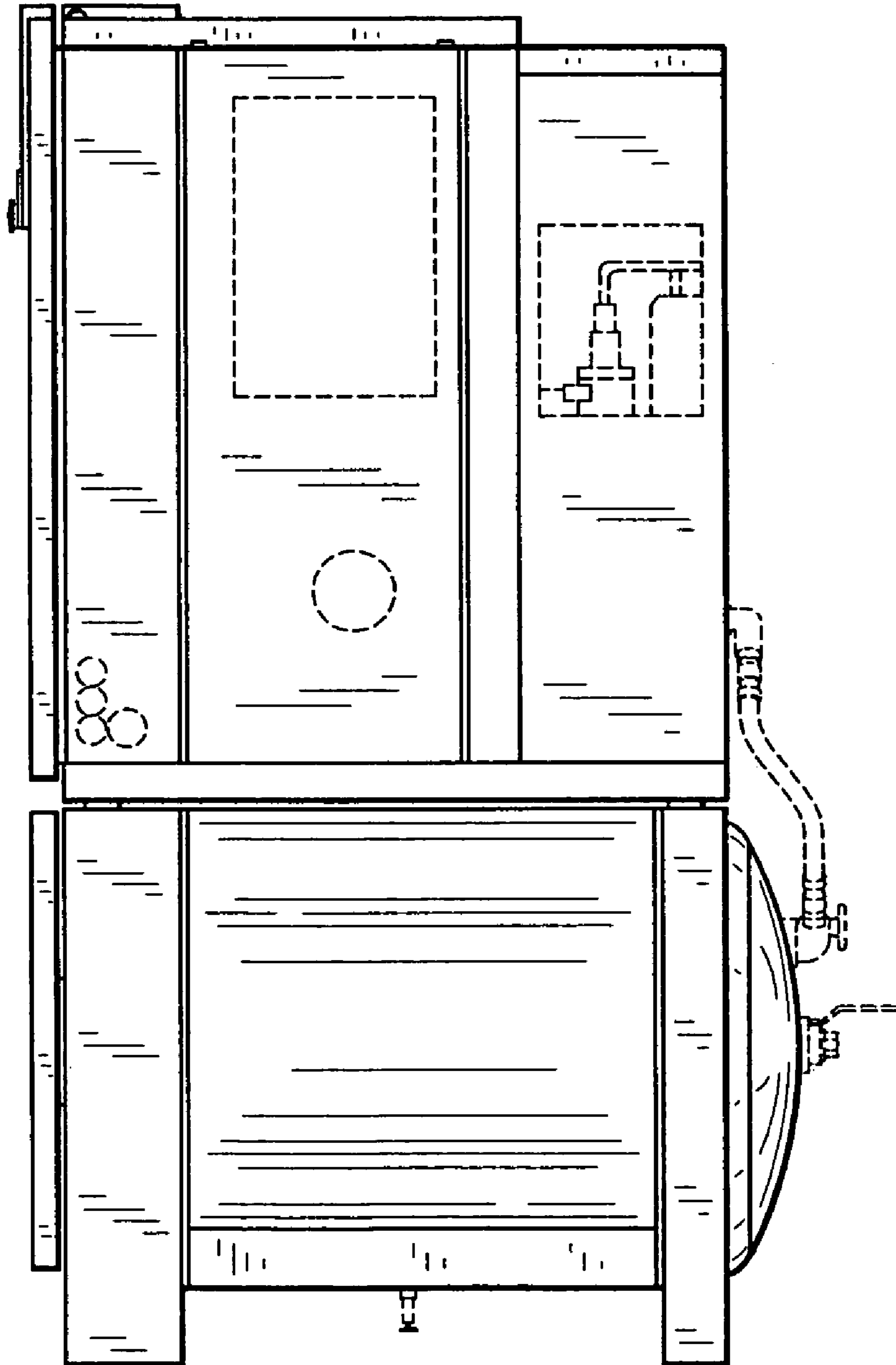

FIG. 3

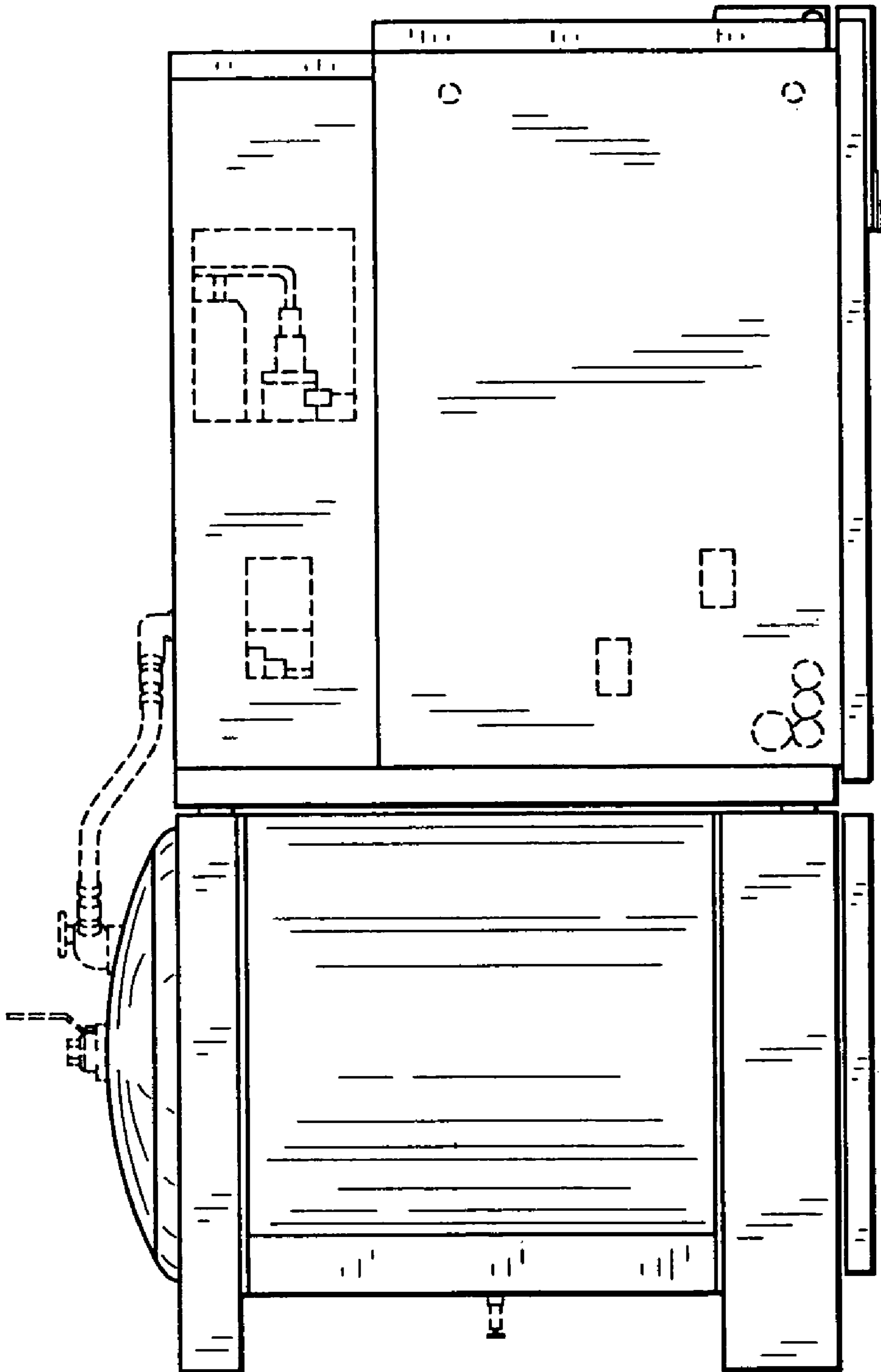

FIG. 4

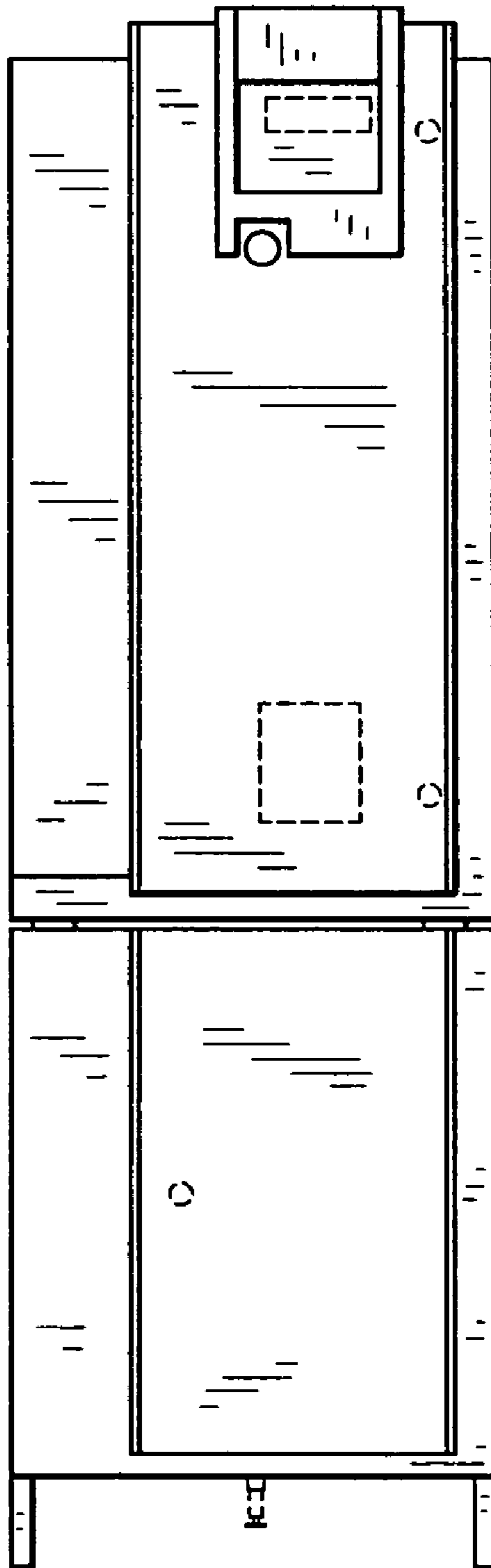

FIG. 5

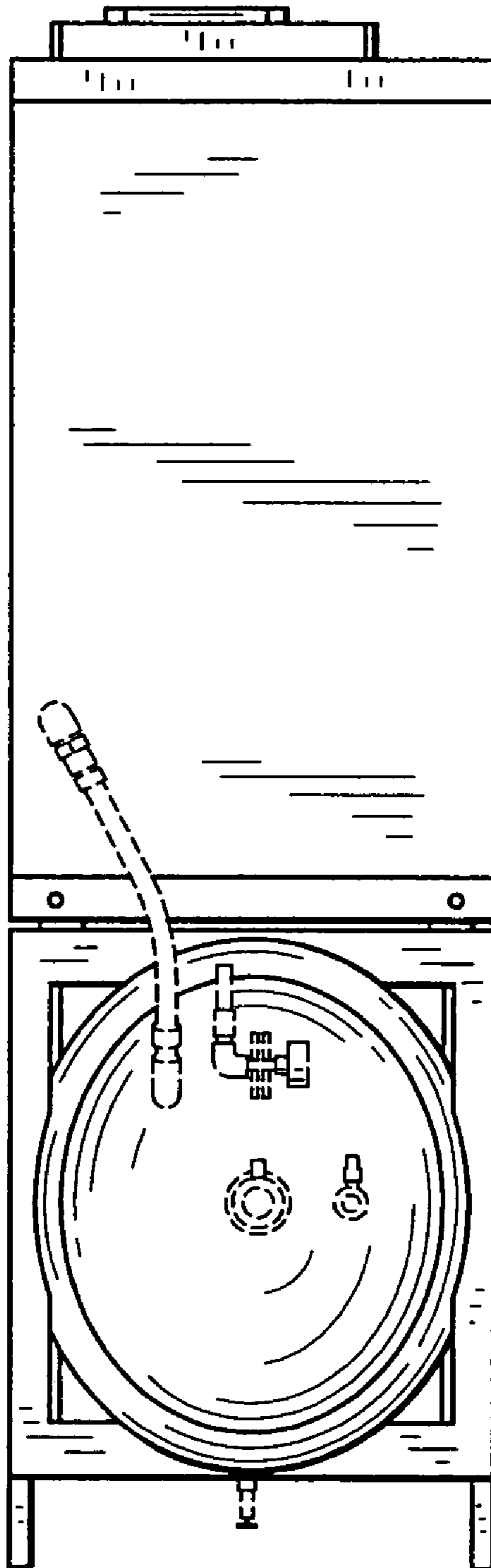

FIG. 6

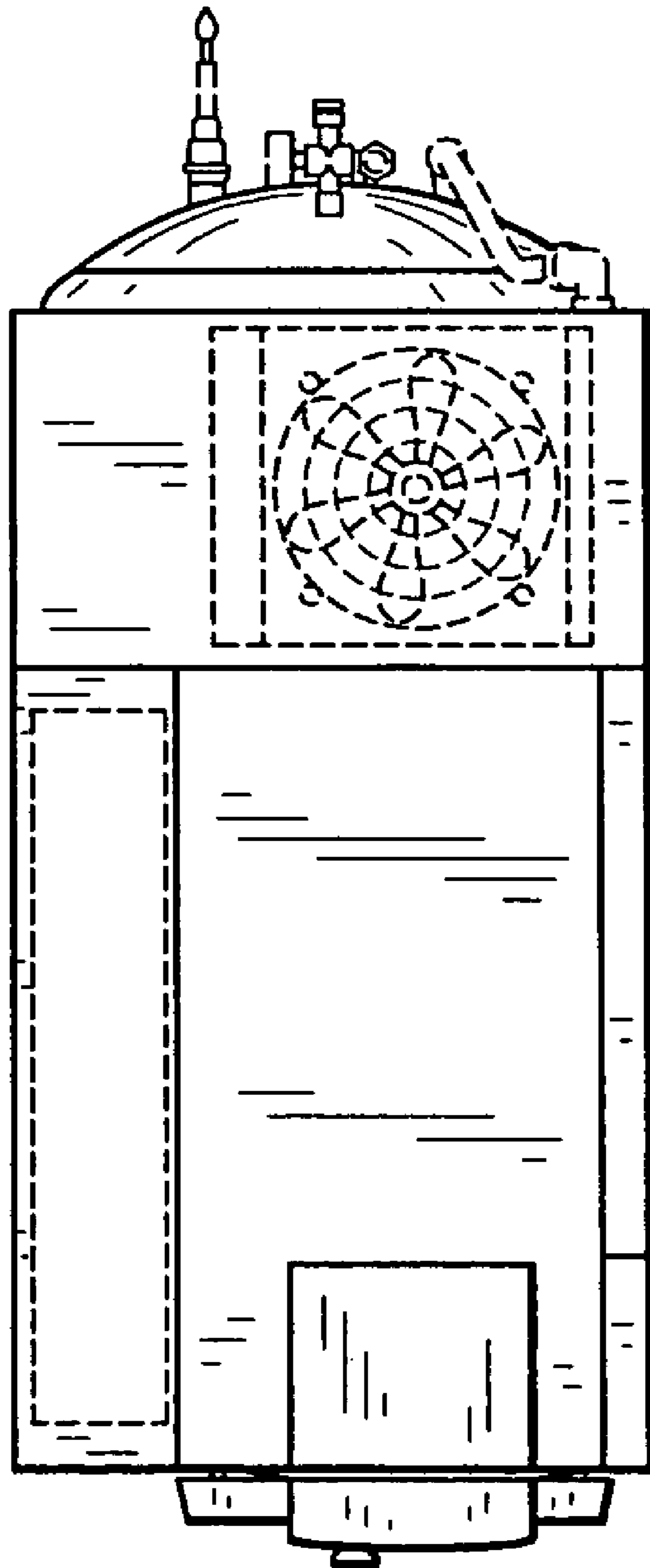

FIG. 7

