



US00D552540S

(12) **United States Design Patent**
Miyauchi et al.

(10) **Patent No.:** **US D552,540 S**

(45) **Date of Patent:** **** Oct. 9, 2007**

(54) **MOTOR FOR OPENING AND SHUTTING OF VEHICLE DOOR**

(75) Inventors: **Kazutoshi Miyauchi**, Yokohama (JP);
Kazutaka Sakonju, Yokohama (JP)

(73) Assignee: **Jidosha Denki Kogyo Co., Ltd.**,
Yokohama (JP)

(**) Term: **14 Years**

(21) Appl. No.: **29/201,488**

(22) Filed: **Mar. 17, 2004**

(30) **Foreign Application Priority Data**

Sep. 17, 2003 (JP) 2003-031244

(51) **LOC (8) Cl.** **13-01**

(52) **U.S. Cl.** **D13/112**

(58) **Field of Classification Search** D13/112,
D13/114, 122, 199; D15/199; 49/28, 139,
49/140, 339, 340, 360; 310/62, 80

See application file for complete search history.

(56) **References Cited**

U.S. PATENT DOCUMENTS

5,680,728 A * 10/1997 Moy 49/324
D386,744 S * 11/1997 Urvoy D13/112
5,768,942 A * 6/1998 Gruber et al. 74/89.14
6,055,775 A * 5/2000 Dering et al. 49/340

6,134,836 A * 10/2000 Kawanobe et al. 49/360
D453,140 S * 1/2002 Buzzard D13/112
6,425,206 B1 * 7/2002 Noda et al. 49/360
6,460,295 B1 * 10/2002 Johnson et al. 49/360

* cited by examiner

Primary Examiner—Prabhakar Deshmukh

Assistant Examiner—Derrick Holland

(74) *Attorney, Agent, or Firm*—Sughrue Mion. PLLC

(57) **CLAIM**

The ornamental design for a motor for opening and shutting of vehicle door, as shown.

DESCRIPTION

FIG. 1 is a perspective view of the top, front and right side of a motor for opening and shutting of vehicle door showing our new design;

FIG. 2 is a perspective view of the bottom, rear and left side thereof;

FIG. 3 is a right side view thereof;

FIG. 4 is a left side view thereof;

FIG. 5 is a front view thereof;

FIG. 6 is a rear view thereof;

FIG. 7 is a top view thereof; and,

FIG. 8 is a bottom view thereof.

1 Claim, 7 Drawing Sheets

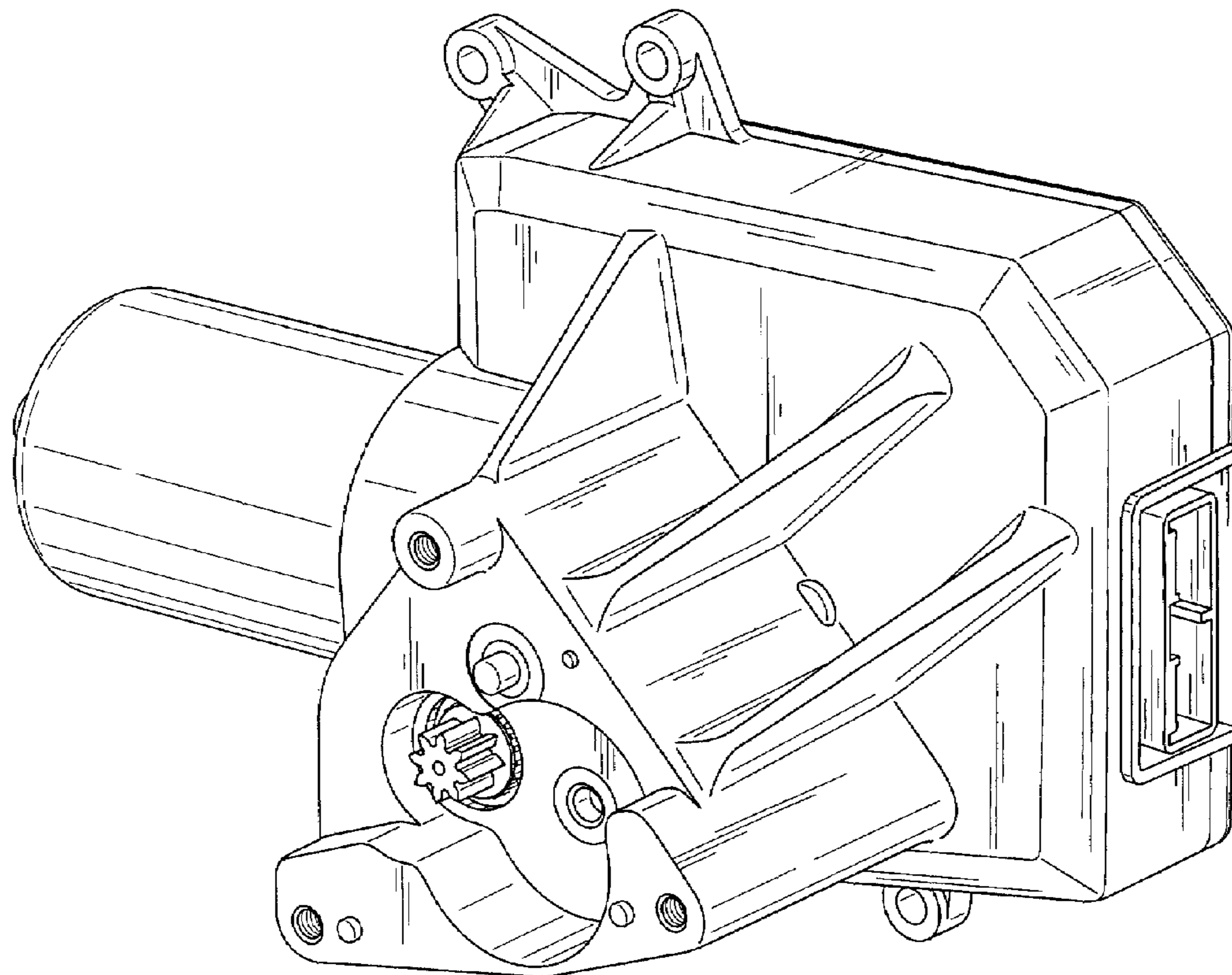

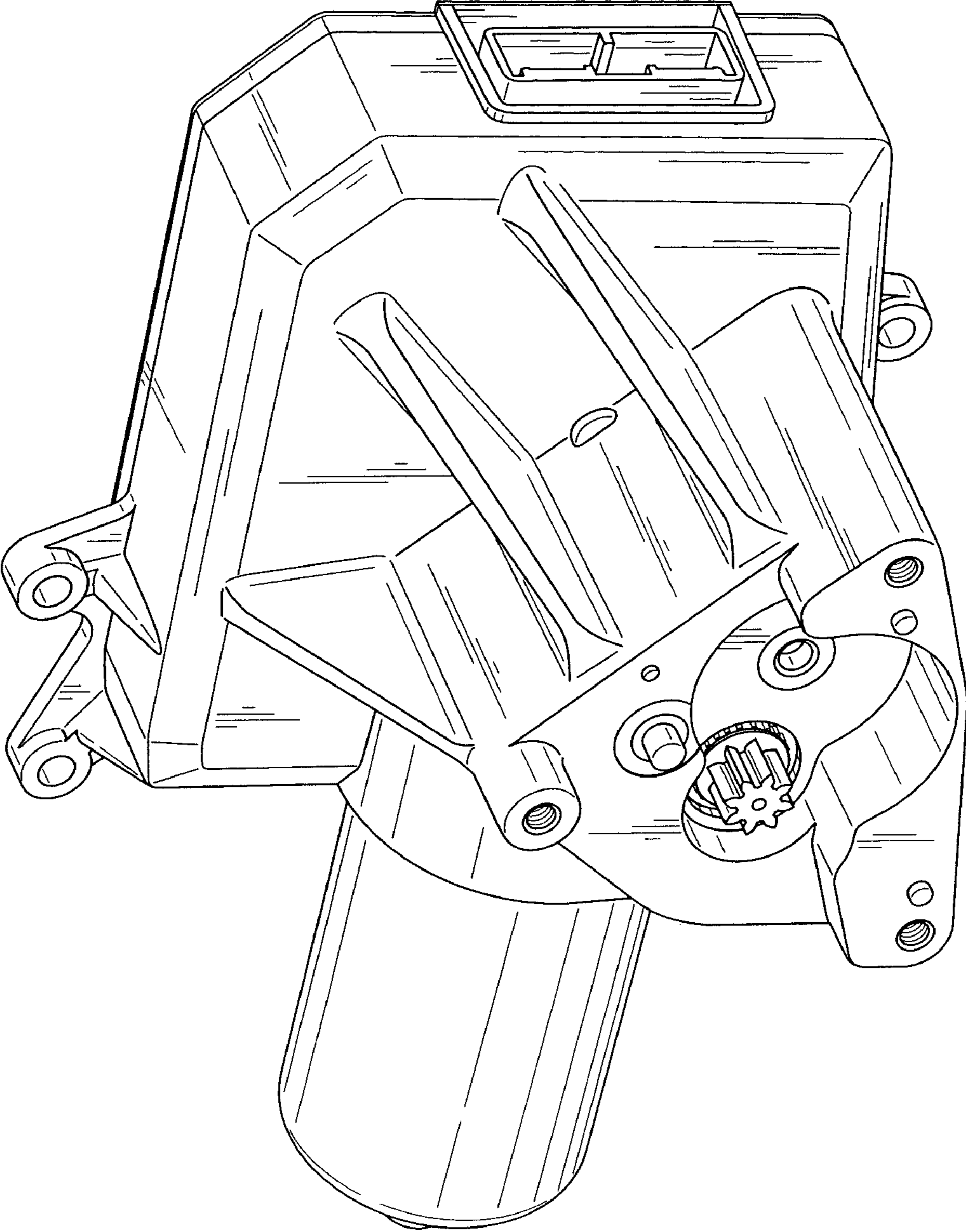

FIG. 1

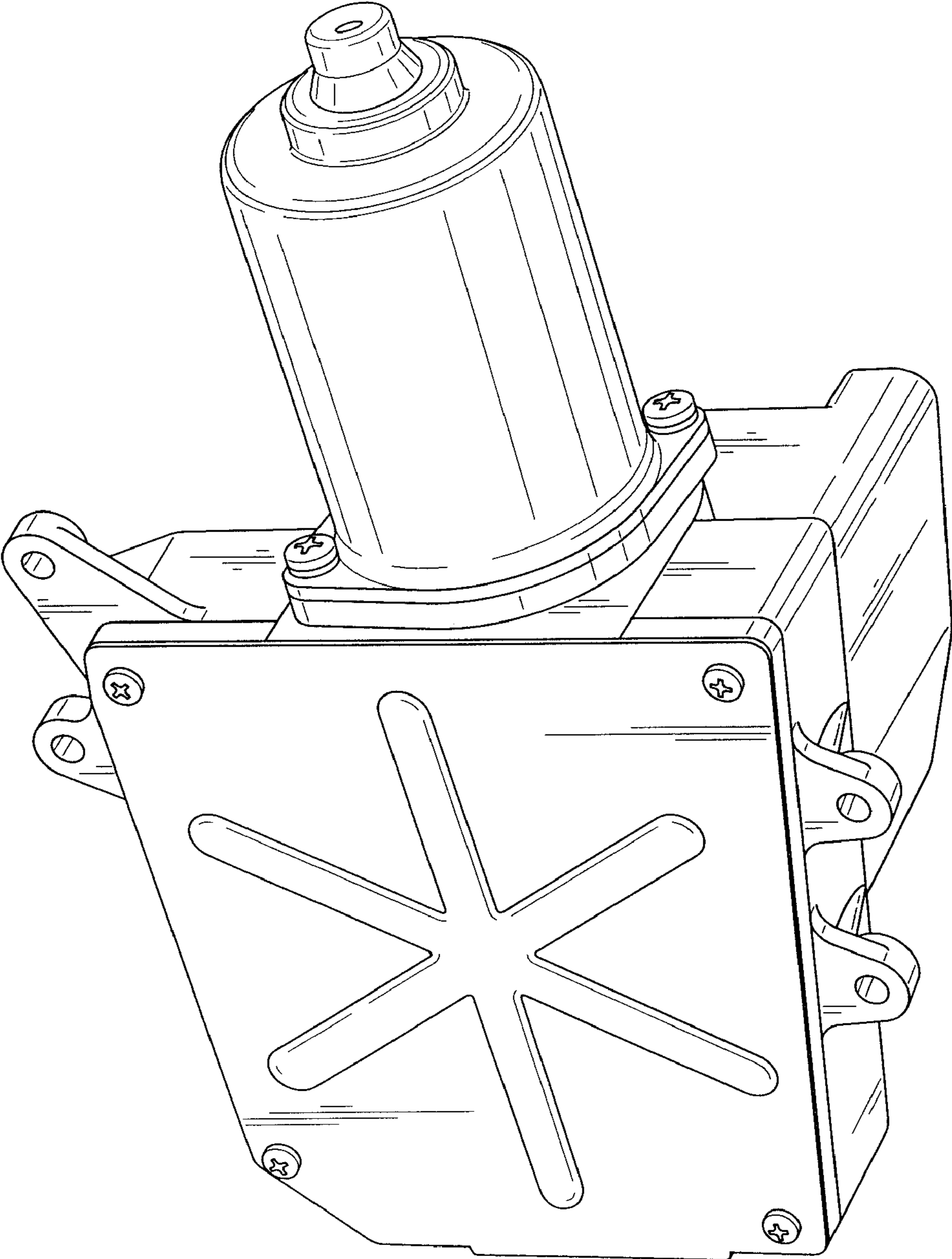

FIG. 2

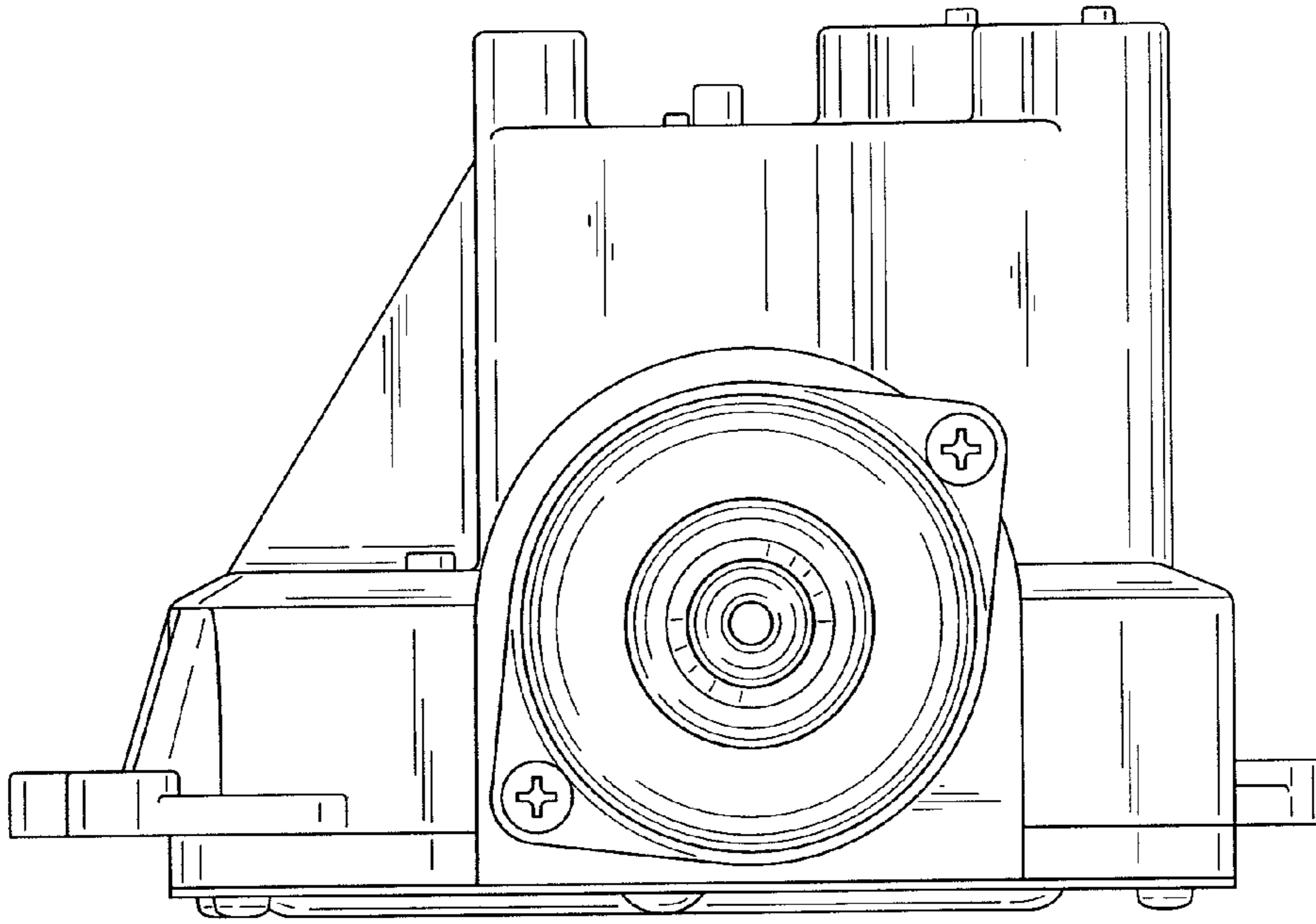

FIG. 4

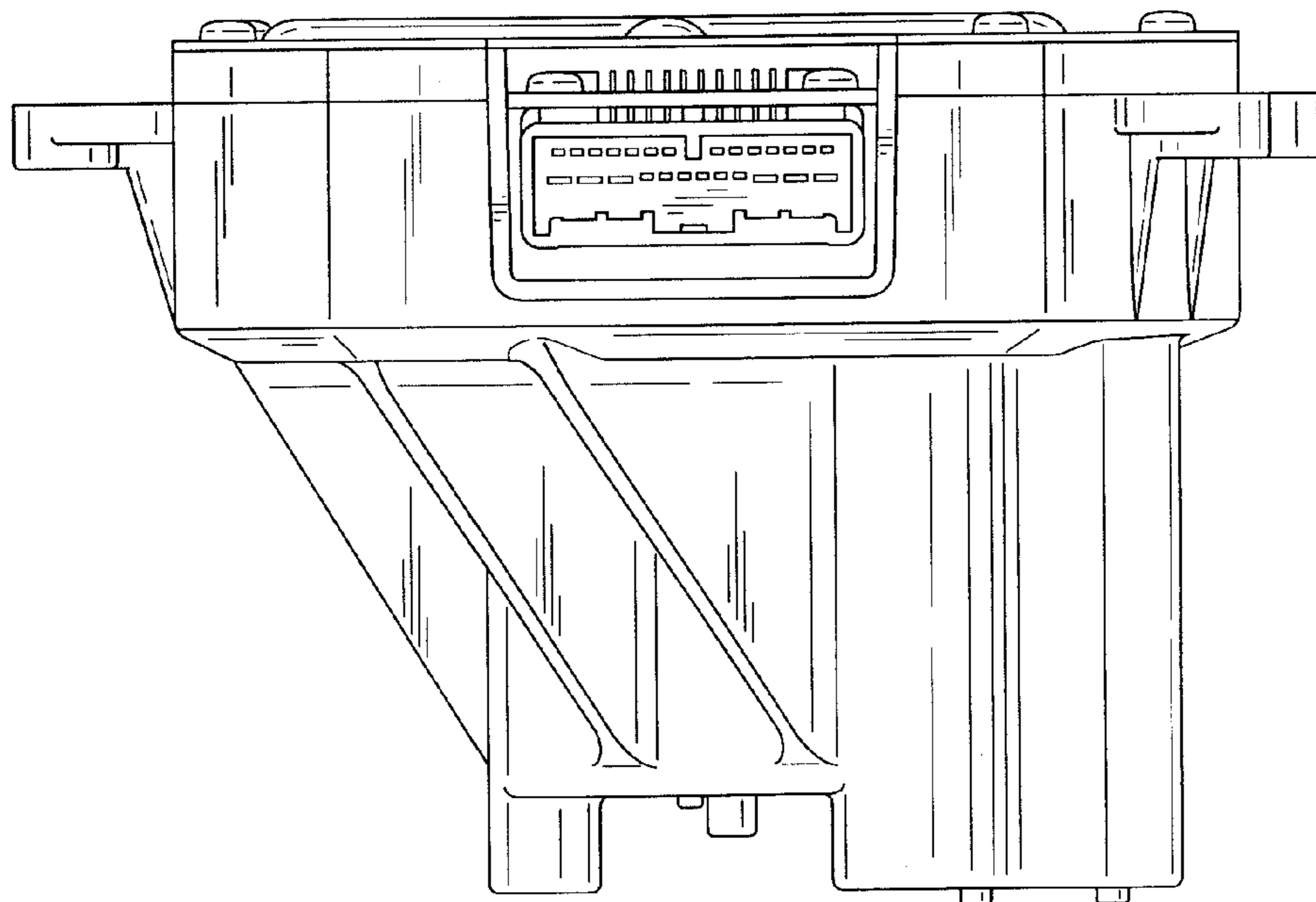

FIG. 3

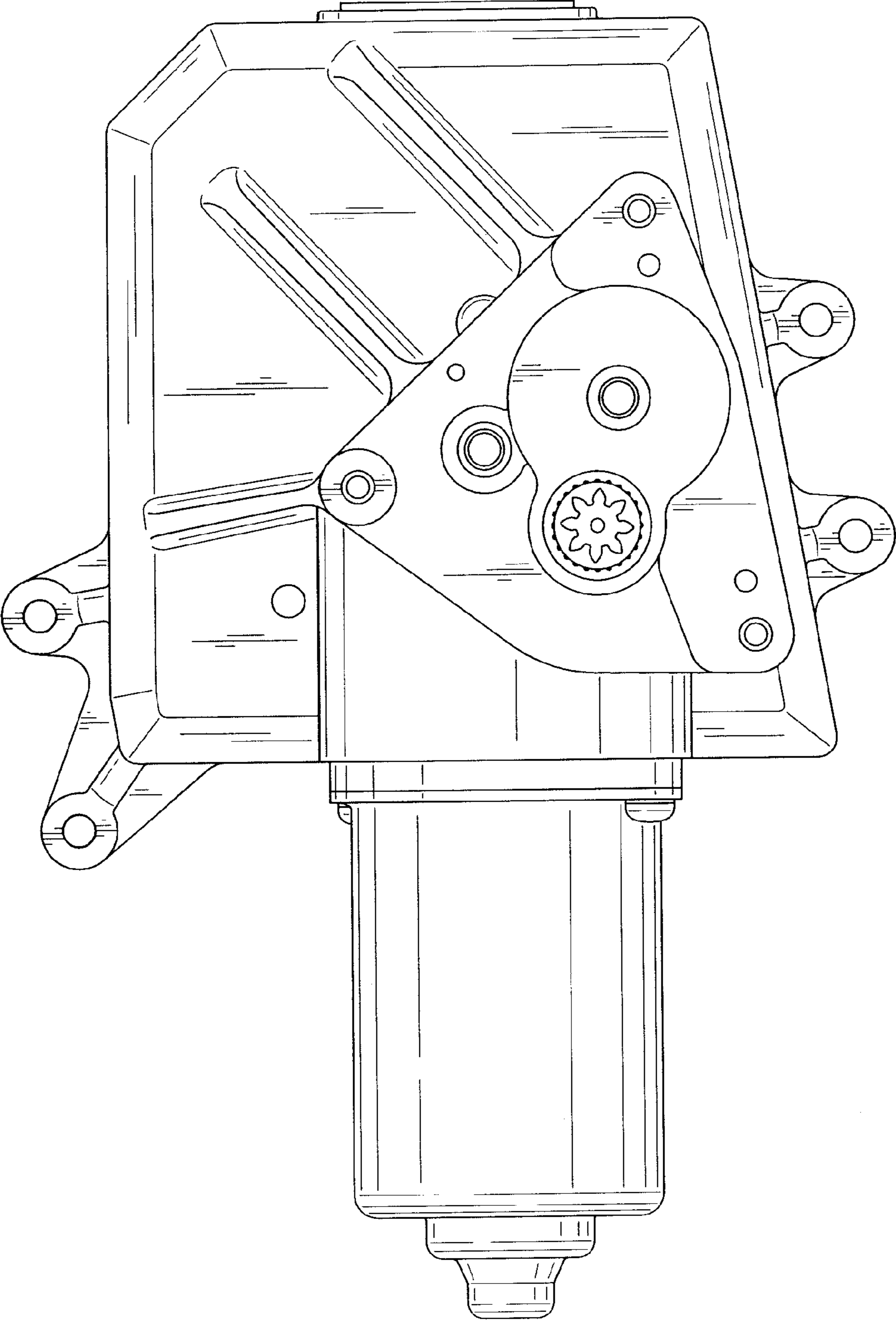

FIG. 5

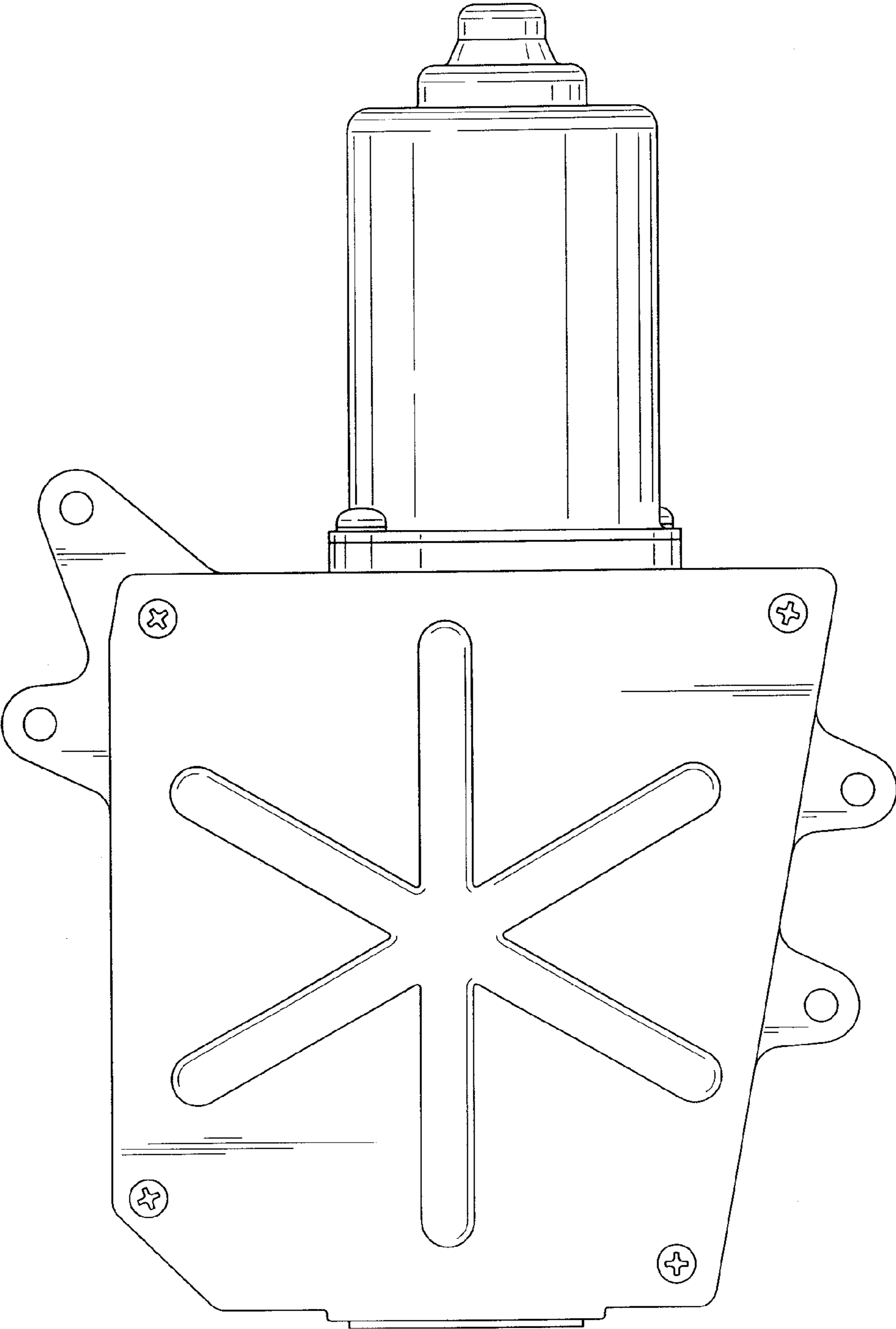

FIG. 6

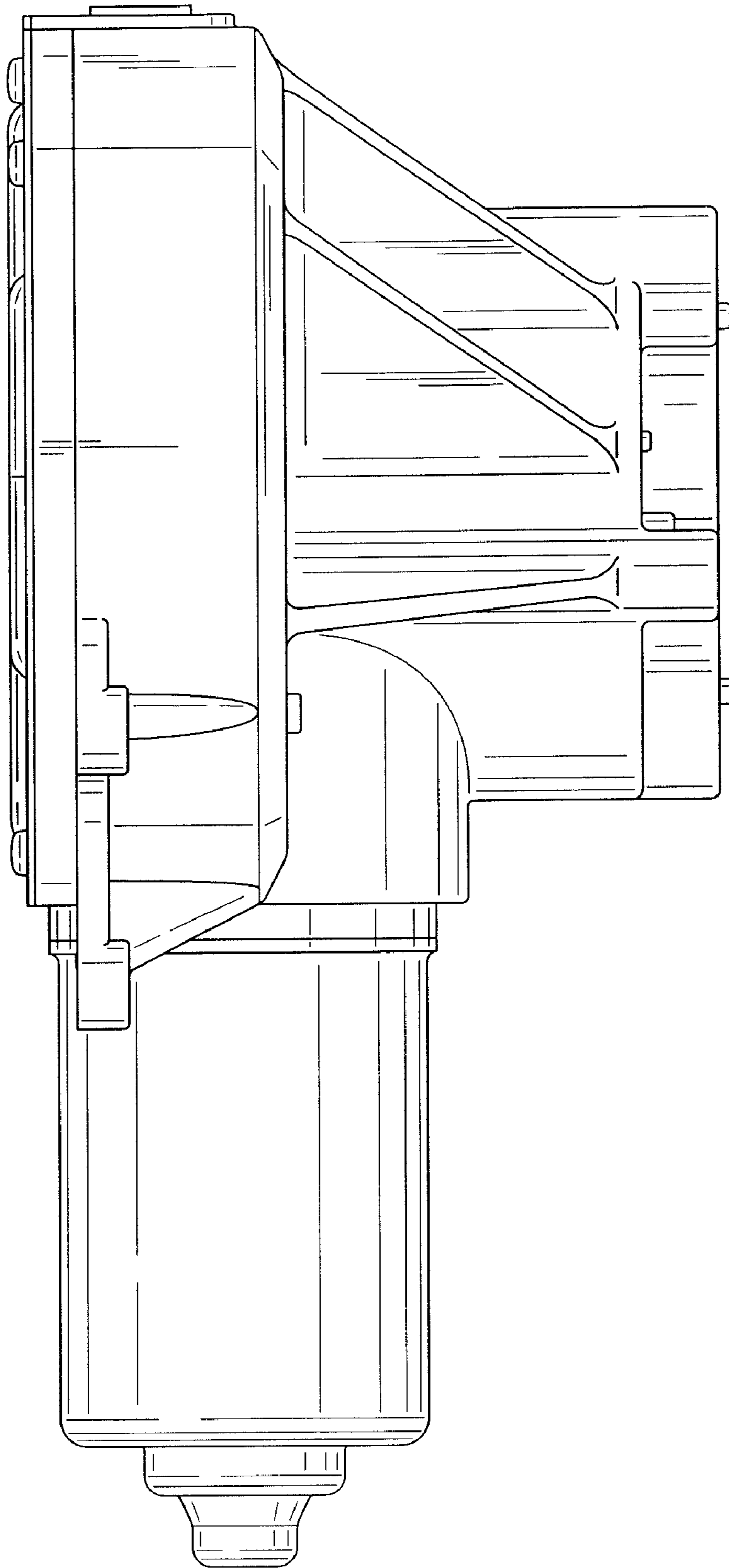

FIG. 7

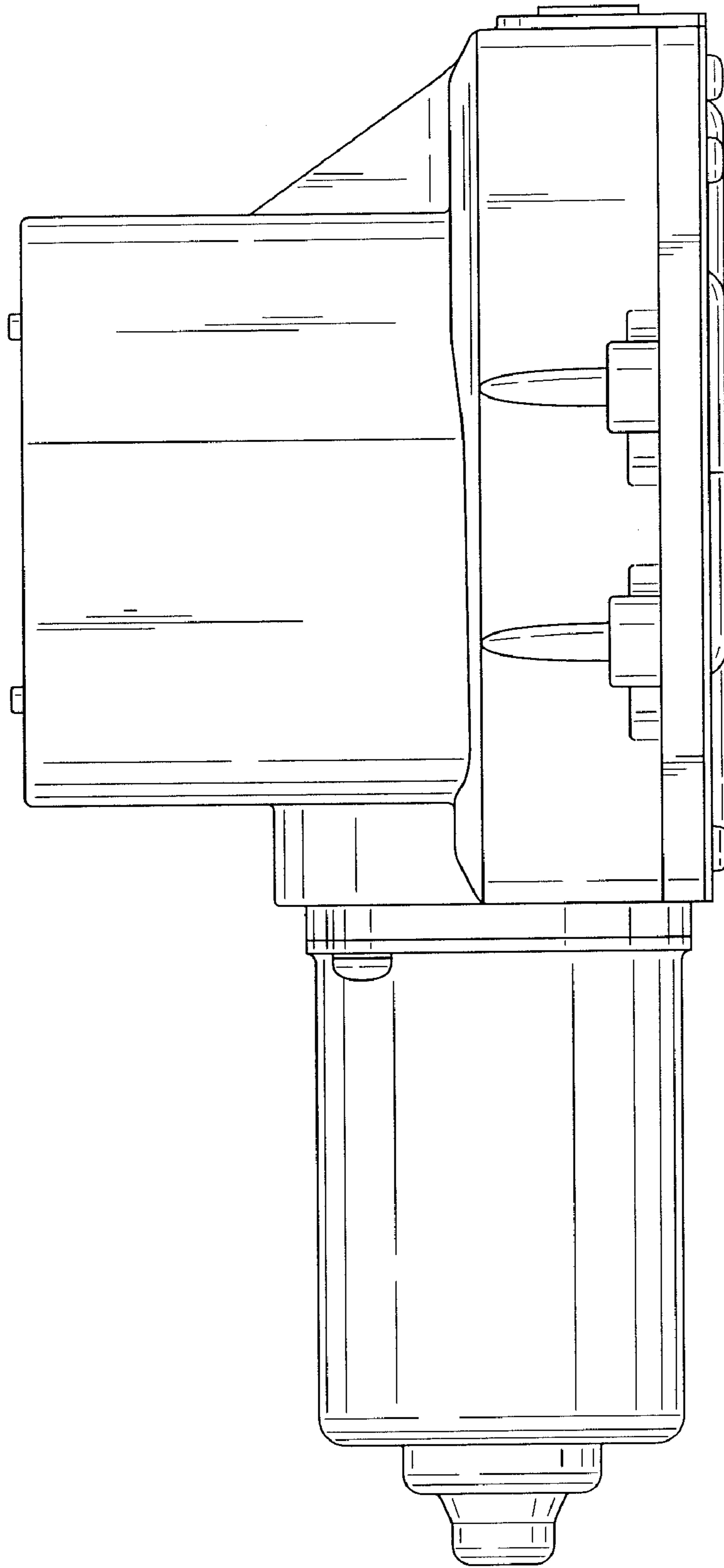

FIG. 8