



US00D552501S

(12) **United States Design Patent**
Lin et al.

(10) **Patent No.:** **US D552,501 S**

(45) **Date of Patent:** **** Oct. 9, 2007**

(54) **HOUSING FOR A SECURITY CAMERA**

(75) Inventors: **Chin-Ting Lin**, Xizhi (TW);
Chen-Shun Su, Keelung (TW)

(73) Assignee: **Cwell Vision Corporation**, Taipei
(TW)

(**) Term: **14 Years**

(21) Appl. No.: **29/244,926**

(22) Filed: **Dec. 16, 2005**

(30) **Foreign Application Priority Data**

Sep. 16, 2005 (TW) 94305557

(51) **LOC (8) Cl.** **10-05**

(52) **U.S. Cl.** **D10/104; D16/203**

(58) **Field of Classification Search** D10/104-121;
348/375, 781; 359/699; 396/427, 535-541;
D16/200-215

See application file for complete search history.

(56) **References Cited**

U.S. PATENT DOCUMENTS

D374,189 S *	10/1996	Hubben	D10/106
D412,924 S *	8/1999	Hiraguchi	D16/219
D416,273 S *	11/1999	Yamakawa et al.	D16/203
D449,630 S *	10/2001	Rak et al.	D16/203
D452,696 S *	1/2002	Fenton	D16/203
D473,888 S *	4/2003	Jones et al.	D16/203
6,678,001 B1 *	1/2004	Elberbaum	348/373

D491,968 S *	6/2004	Isshiki	D16/203
D494,992 S *	8/2004	Seo	D16/203
D497,927 S *	11/2004	Arbuckle et al.	D16/203
D499,125 S *	11/2004	Adachi et al.	D16/203
D499,126 S *	11/2004	Kato et al.	D16/203
6,896,423 B2 *	5/2005	Arbuckle et al.	396/427
D513,028 S *	12/2005	Maruyama	D16/203
7,011,460 B1 *	3/2006	Todd et al.	396/427
D525,231 S *	7/2006	McMillen et al.	D14/149
2003/0103161 A1 *	6/2003	Tatewaki et al.	348/375

* cited by examiner

Primary Examiner—Robert M. Spear

Assistant Examiner—George D. Kirschbaum

(74) *Attorney, Agent, or Firm*—Troxell Law Office, PLLC

(57) **CLAIM**

The ornamental design for a housing for a security camera, as shown and described.

DESCRIPTION

FIG. 1 is a perspective view of a housing for a security camera showing my design;

FIG. 2 is a front elevational view thereof;

FIG. 3 is a rear elevational view thereof;

FIG. 4 is a left side elevational view thereof;

FIG. 5 is a right side elevational view thereof; and,

FIG. 6 is a top plan view thereof.

1 Claim, 4 Drawing Sheets

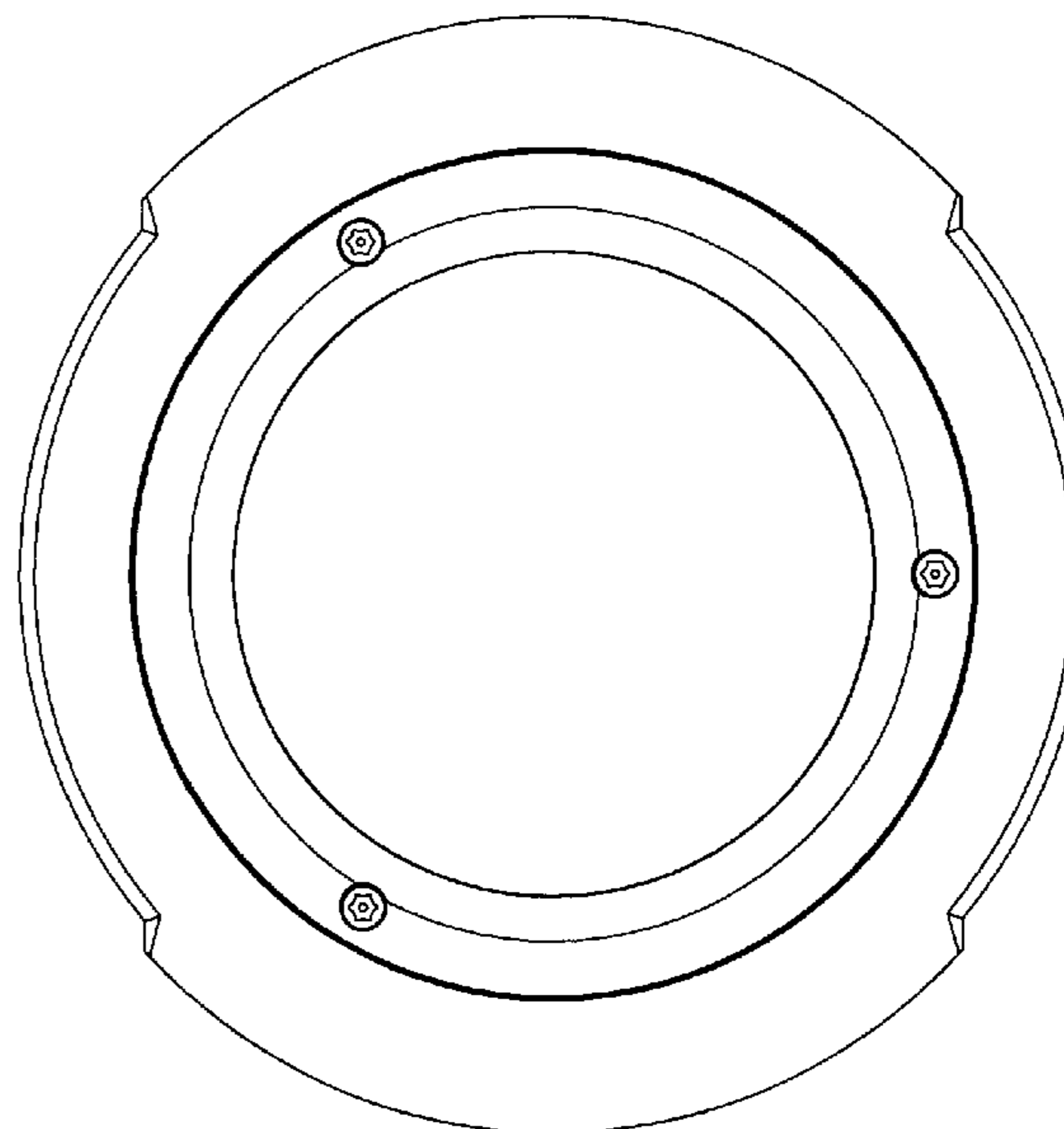
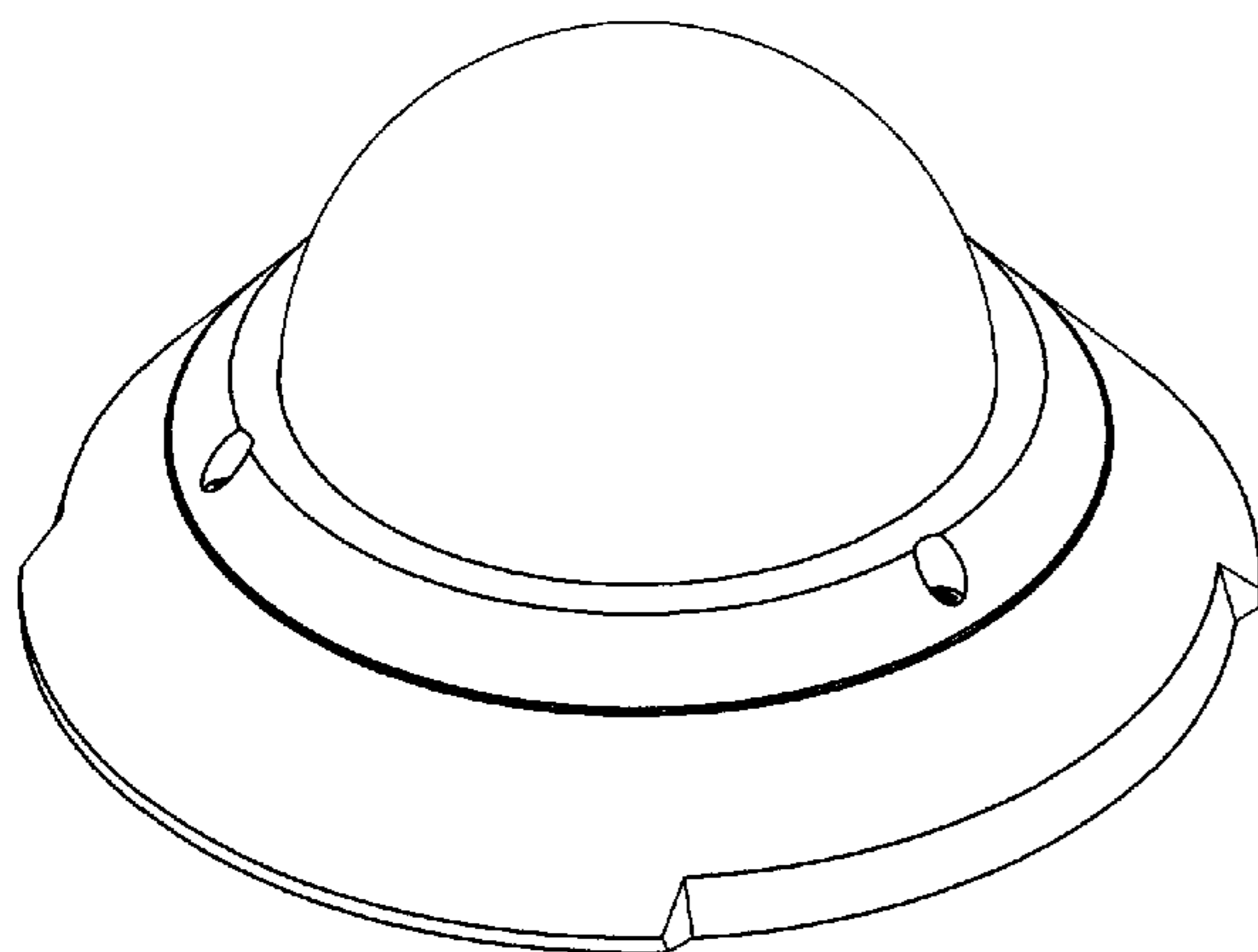

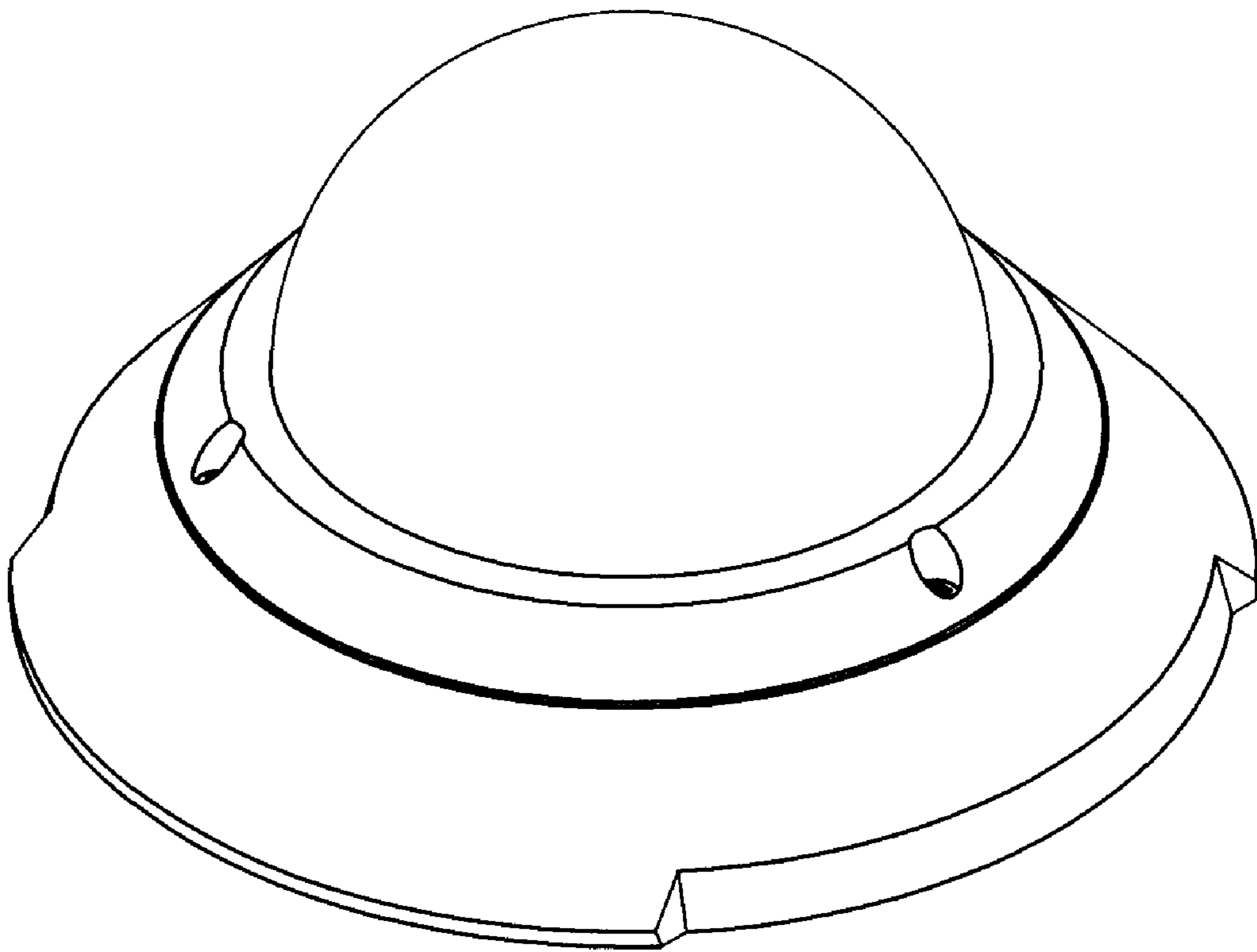

FIG. 1

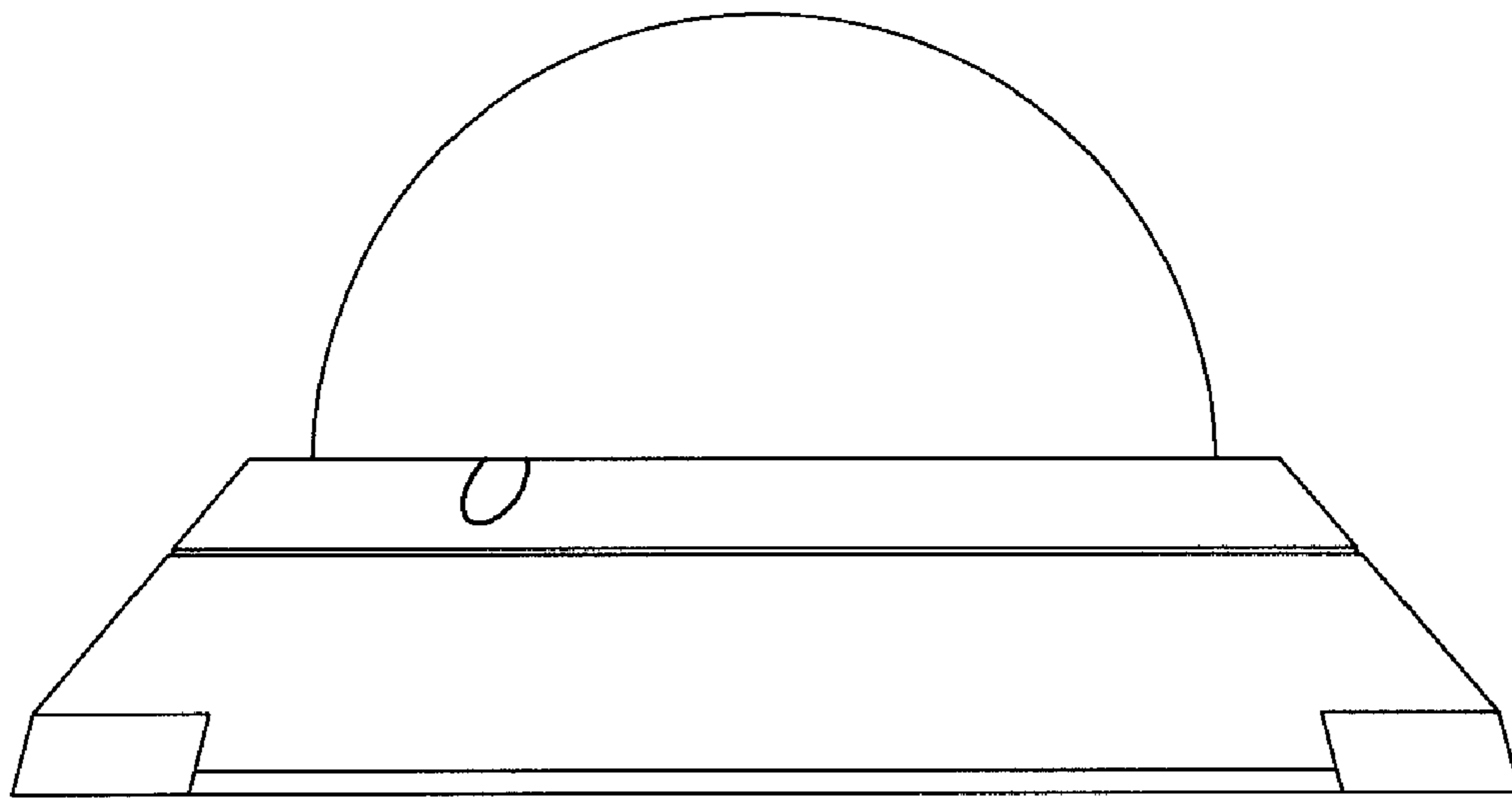

FIG. 2

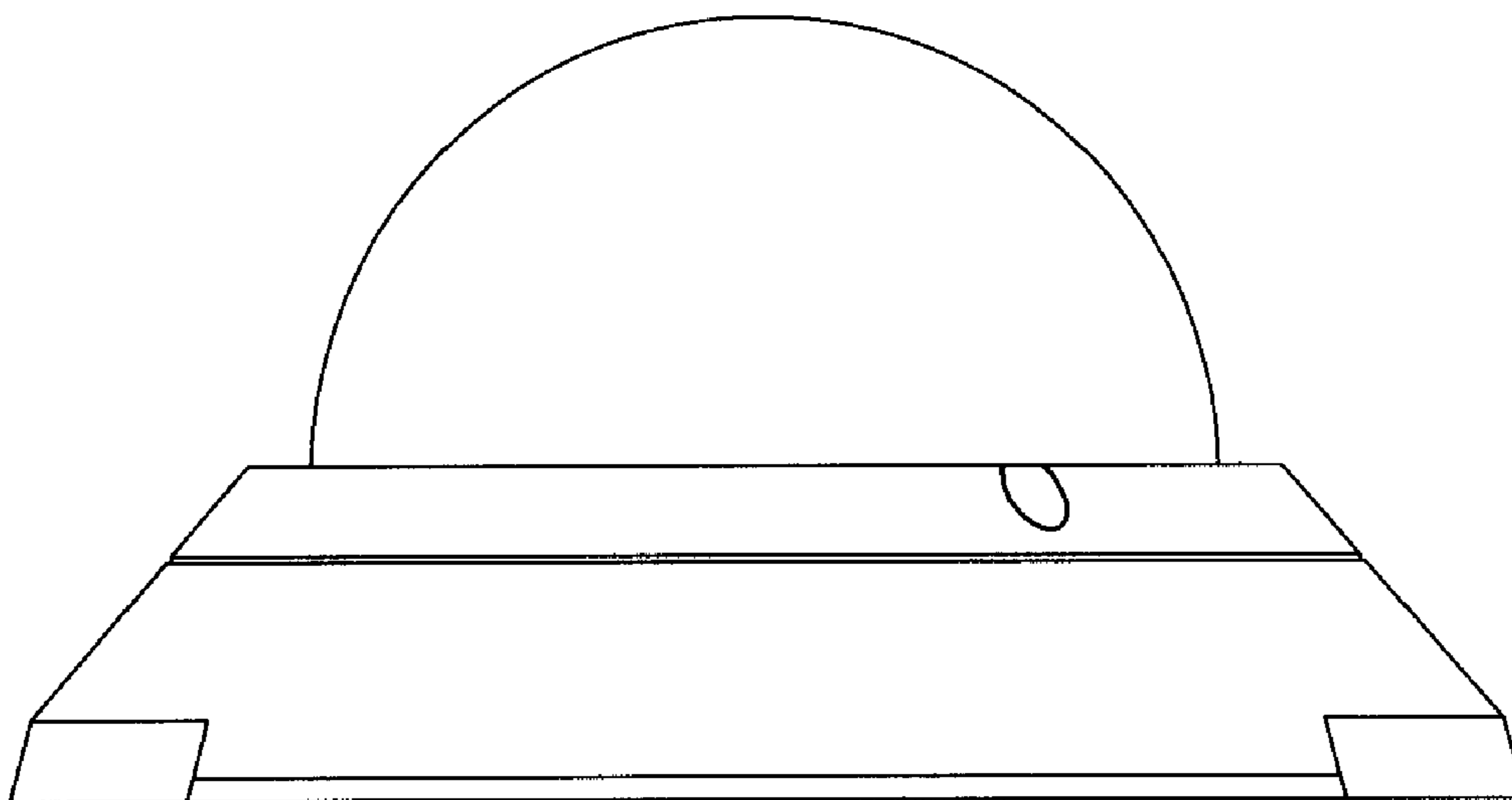

FIG. 3

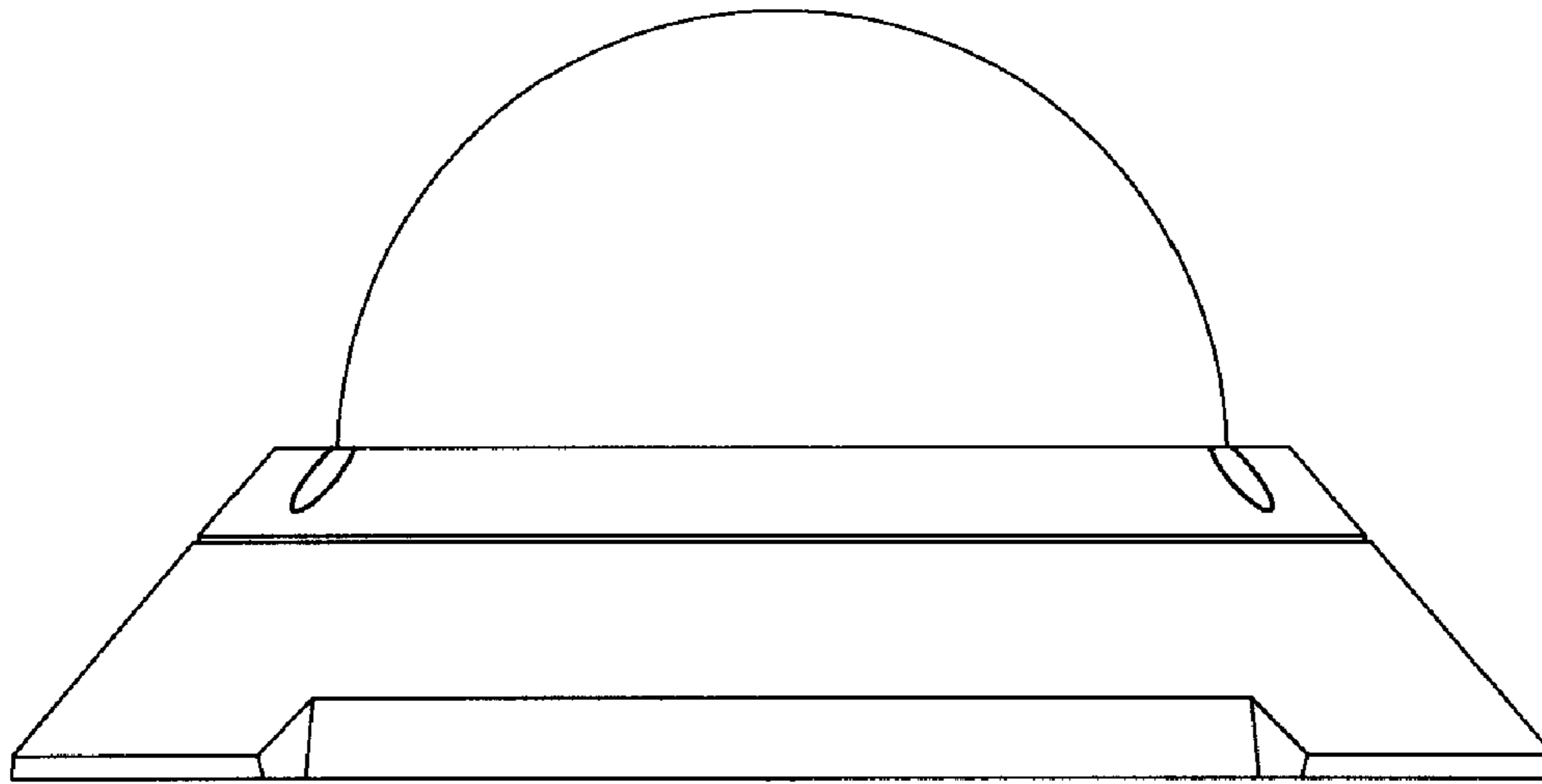

FIG. 4

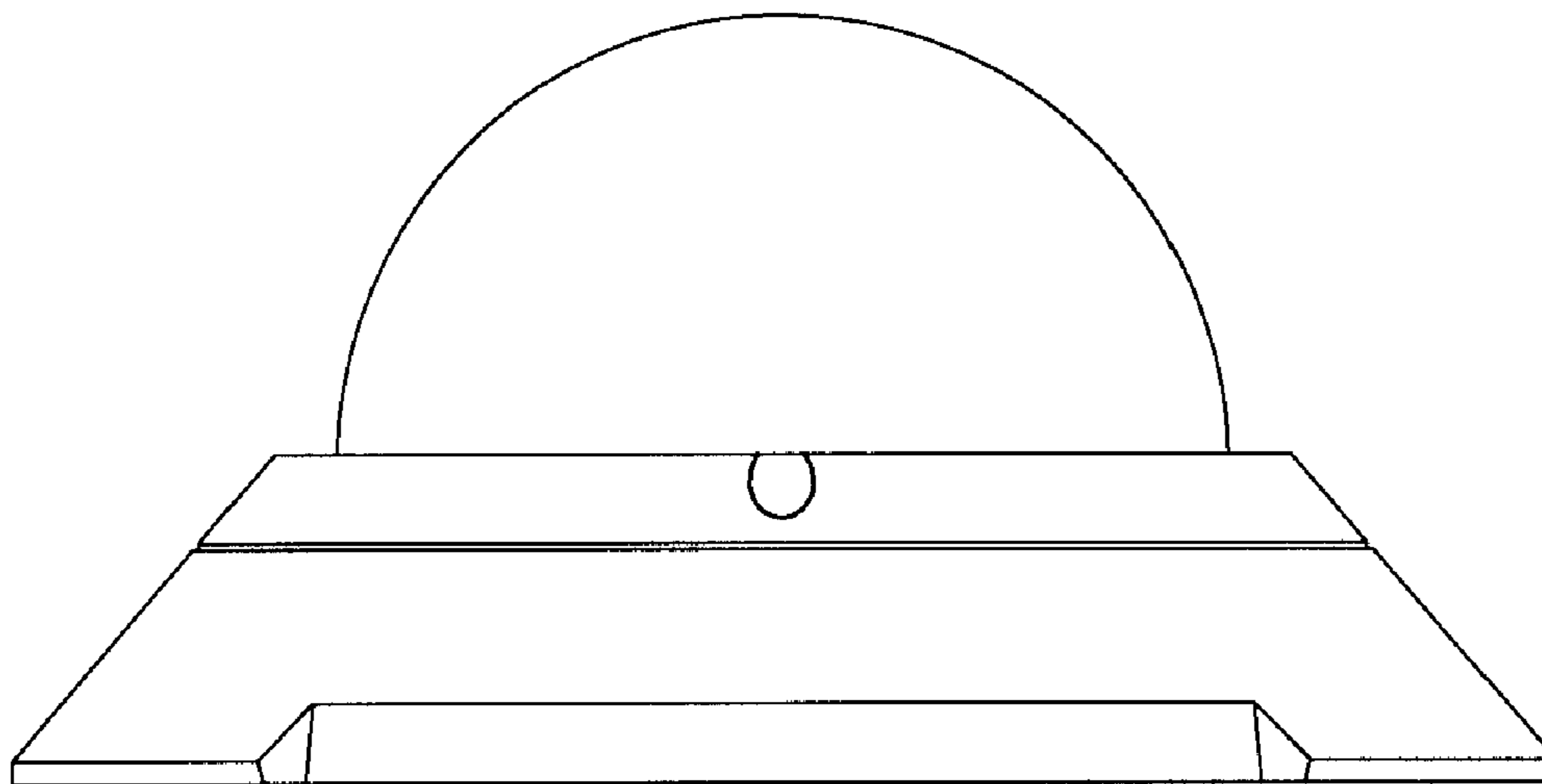

FIG. 5

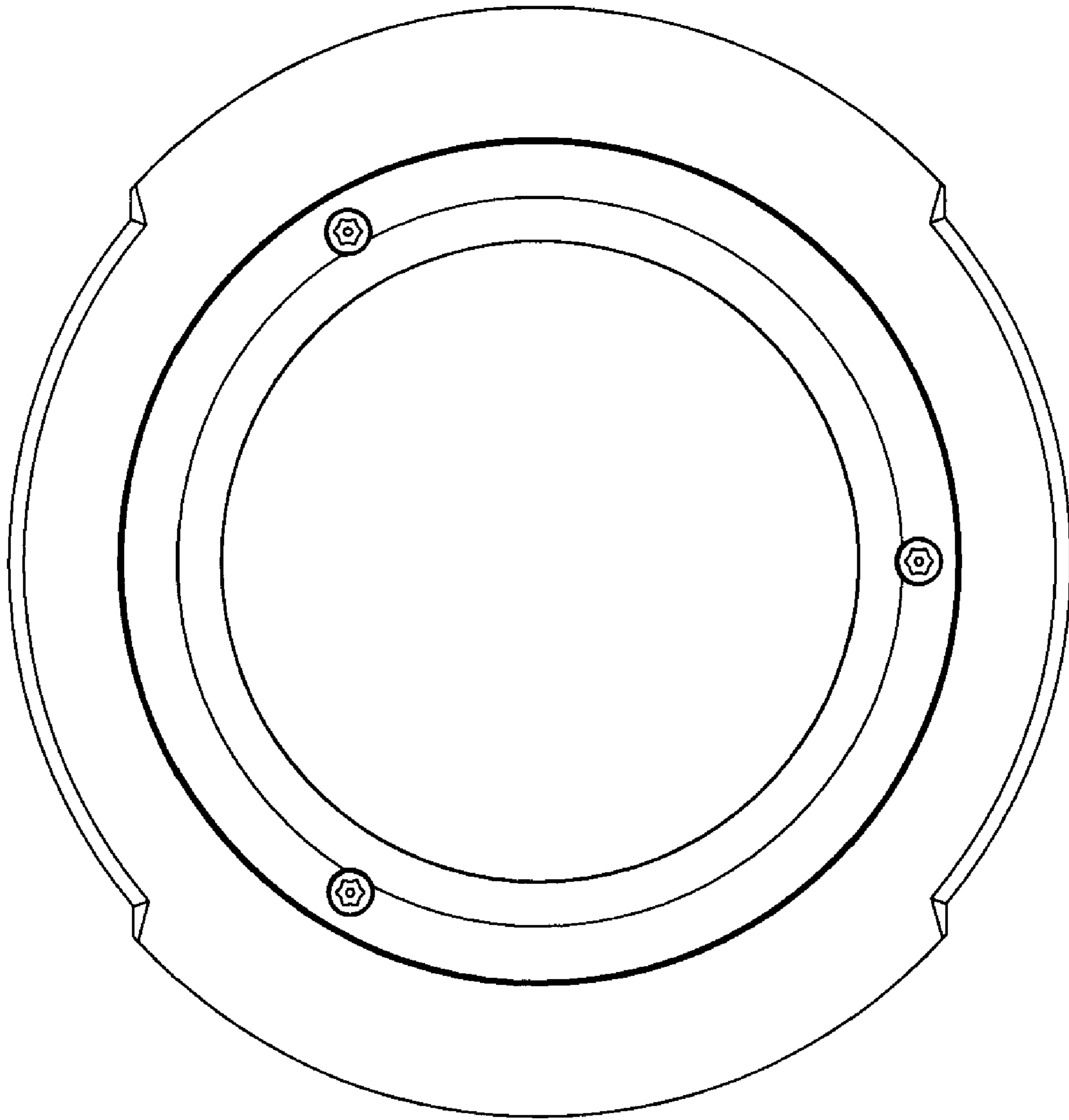

FIG. 6