



US00D552161S

(12) **United States Design Patent** (10) **Patent No.:** **US D552,161 S**
Wilcox (45) **Date of Patent:** **** Oct. 2, 2007**

(54) **BOW FOR STRINGED MUSICAL INSTRUMENTS**

(76) Inventor: **Edward B. Wilcox**, 25 Triangle La., #37C, Batesville, AR (US) 72501

(**) Term: **14 Years**

(21) Appl. No.: **29/224,983**

(22) Filed: **Mar. 10, 2005**

(51) **LOC (8) Cl.** **17-03**

(52) **U.S. Cl.** **D17/20**

(58) **Field of Classification Search** D17/20, D17/99; 84/10, 256, 257, 282-325
See application file for complete search history.

(56) **References Cited**

U.S. PATENT DOCUMENTS

1,646,118	A *	10/1927	Stadniczek	84/282
2,333,013	A *	10/1943	Kaston	84/282
D322,449	S *	12/1991	Hunt	D17/20
D367,668	S *	3/1996	Lindauer	D17/20
5,670,727	A *	9/1997	Xiao	84/283
5,783,762	A *	7/1998	Lindauer	84/282

FOREIGN PATENT DOCUMENTS

DE 3707067 A1 * 9/1988

OTHER PUBLICATIONS

The Early Music Shop. <http://www.e-m-s.com/cat/stringinstruments/bows/bows.htm>. Date Unknown: Viewed Apr. 2007. Waidler Early Bows: center of page.*

Edinburgh University Collection of Historic Musical Instruments. <http://www.music.ed.ac.uk/euchmi/ucj/ucjtc.html>. Sep. 2004. Bow for Bass: left of page.*

* cited by examiner

Primary Examiner—A. Aronovich

Assistant Examiner—R. Johnson

(74) *Attorney, Agent, or Firm*—Stephen D. Carver

(57) **CLAIM**

The ornamental design for a bow for stringed musical instruments, as shown and described.

DESCRIPTION

FIG. 1 is a front isometric view of a bow for stringed musical instruments showing my new design;

FIG. 2 is a bottom isometric view thereof;

FIG. 3 is a top isometric view thereof;

FIG. 4 is an enlarged, fragmentary, top isometric view thereof;

FIG. 5 is an enlarged, fragmentary, bottom isometric view thereof;

FIG. 6 is a top plan view thereof;

FIG. 7 is a side elevational view thereof; the undisclosed opposite side being a mirror image;

FIG. 8 is an enlarged, fragmentary, bottom plan view thereof;

FIG. 9 is and enlarged end view, taken generally from a position to the right of FIG. 4; and,

FIG. 10 is and enlarged end view, taken generally from a position to the left of FIG. 4.

The broken lines shown in FIG. 5 represent an indeterminate length and form no part of the claimed design.

1 Claim, 8 Drawing Sheets

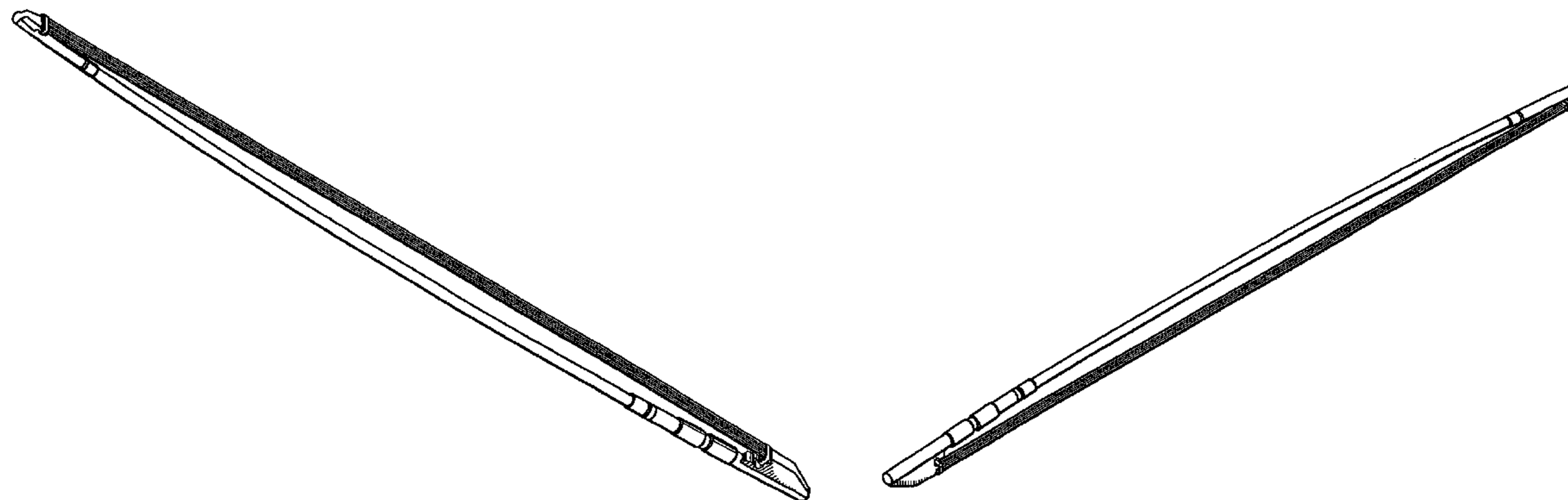

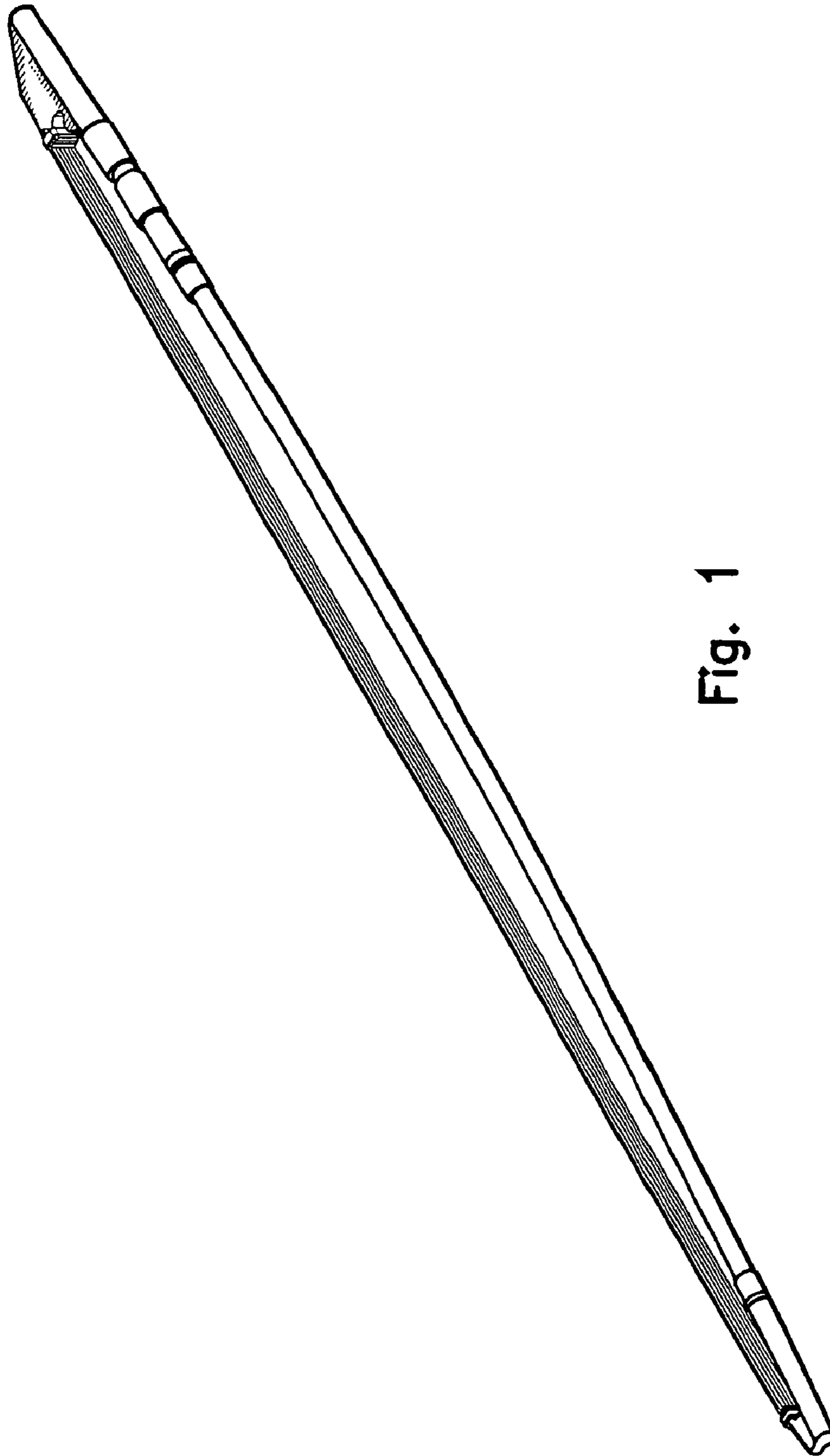

Fig. 1

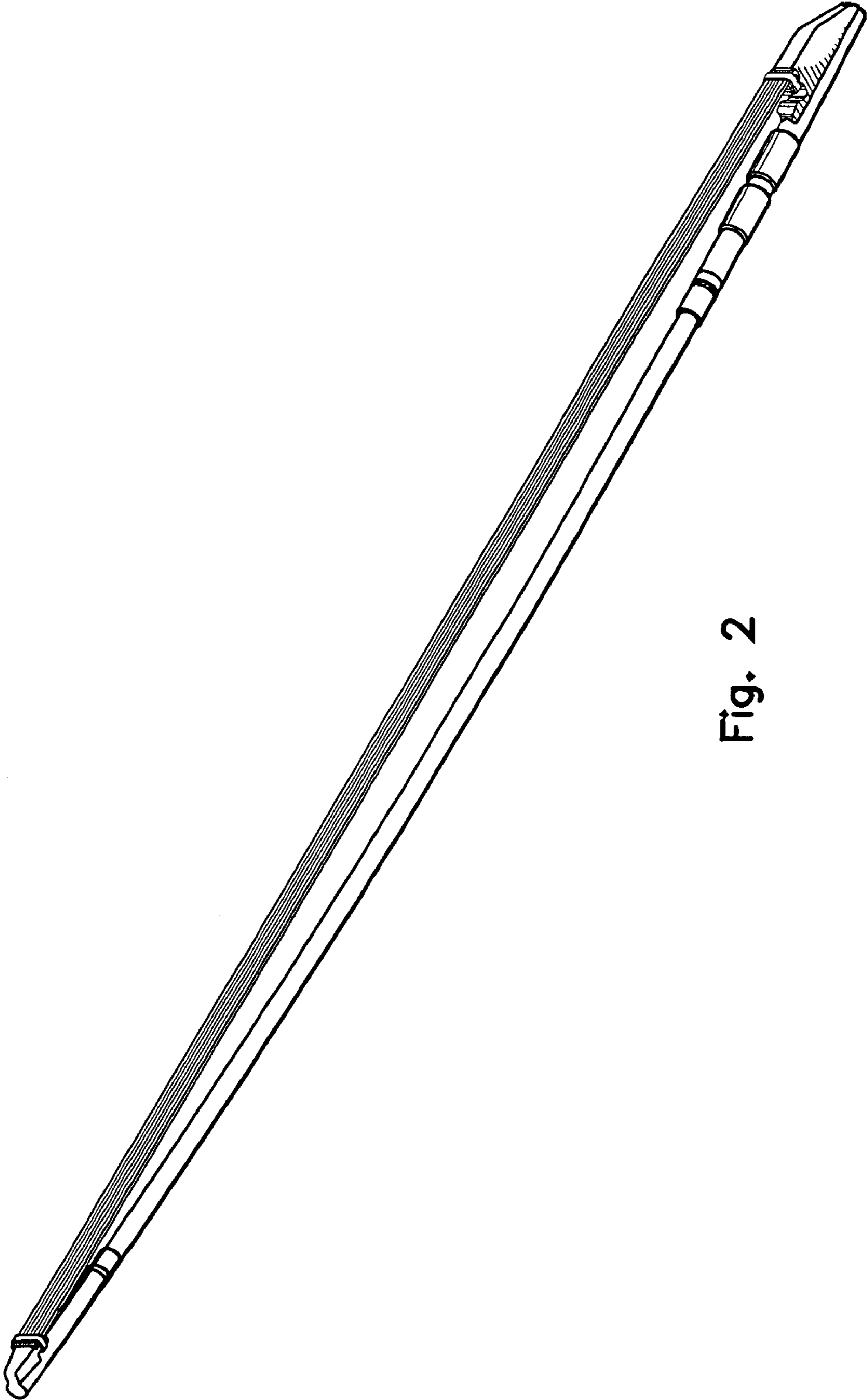

Fig. 2

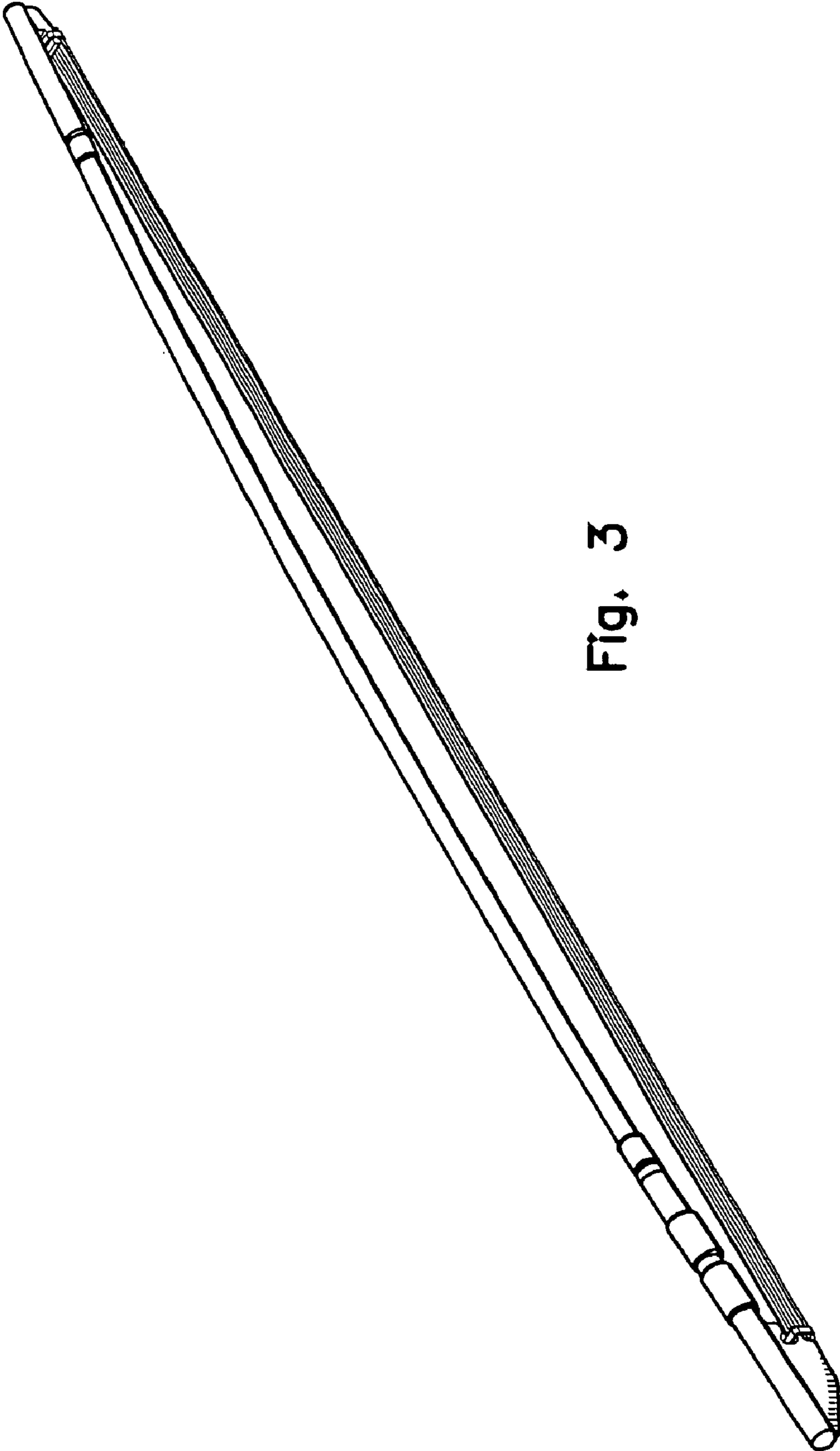

Fig. 3

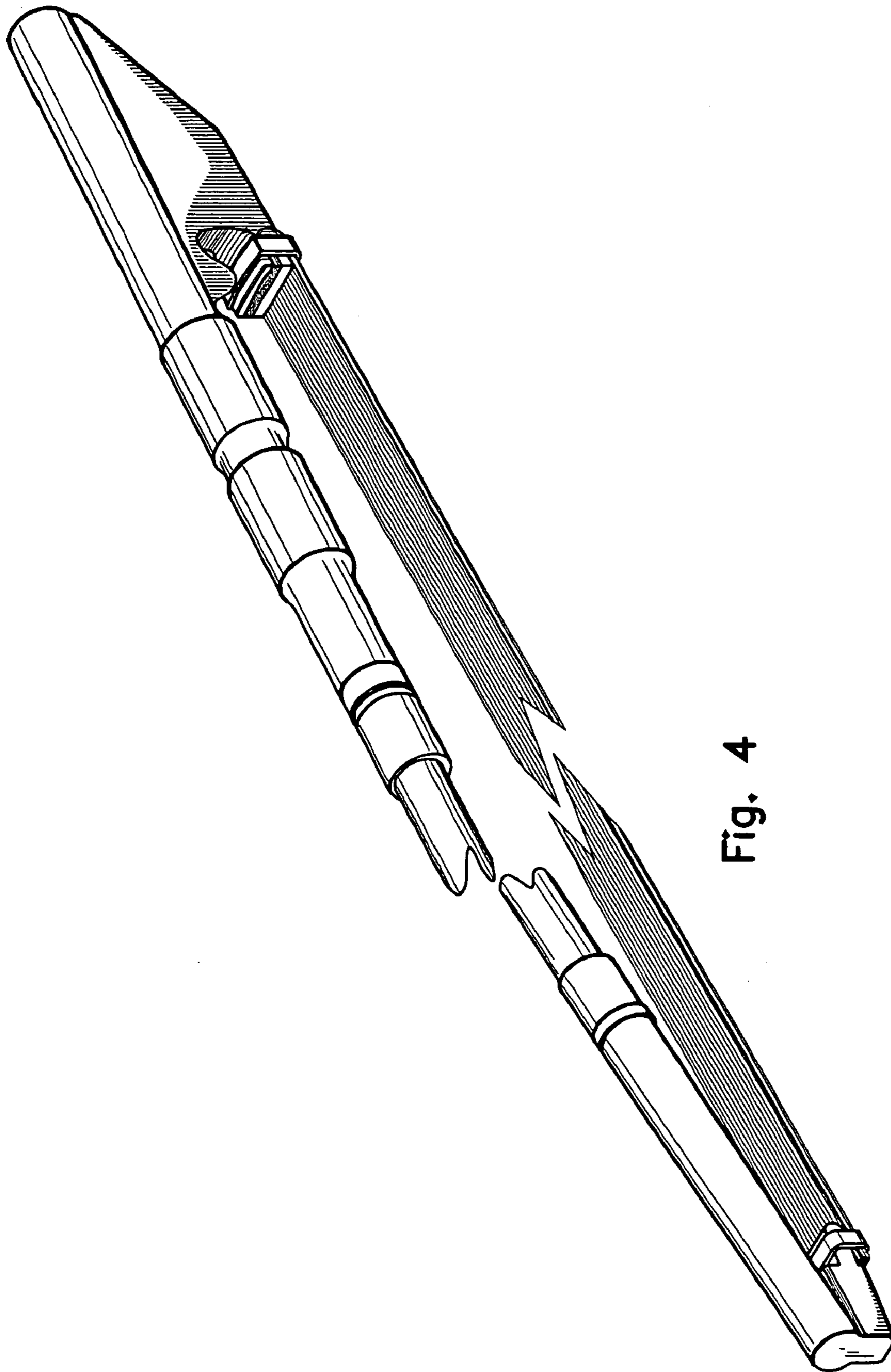

Fig. 4

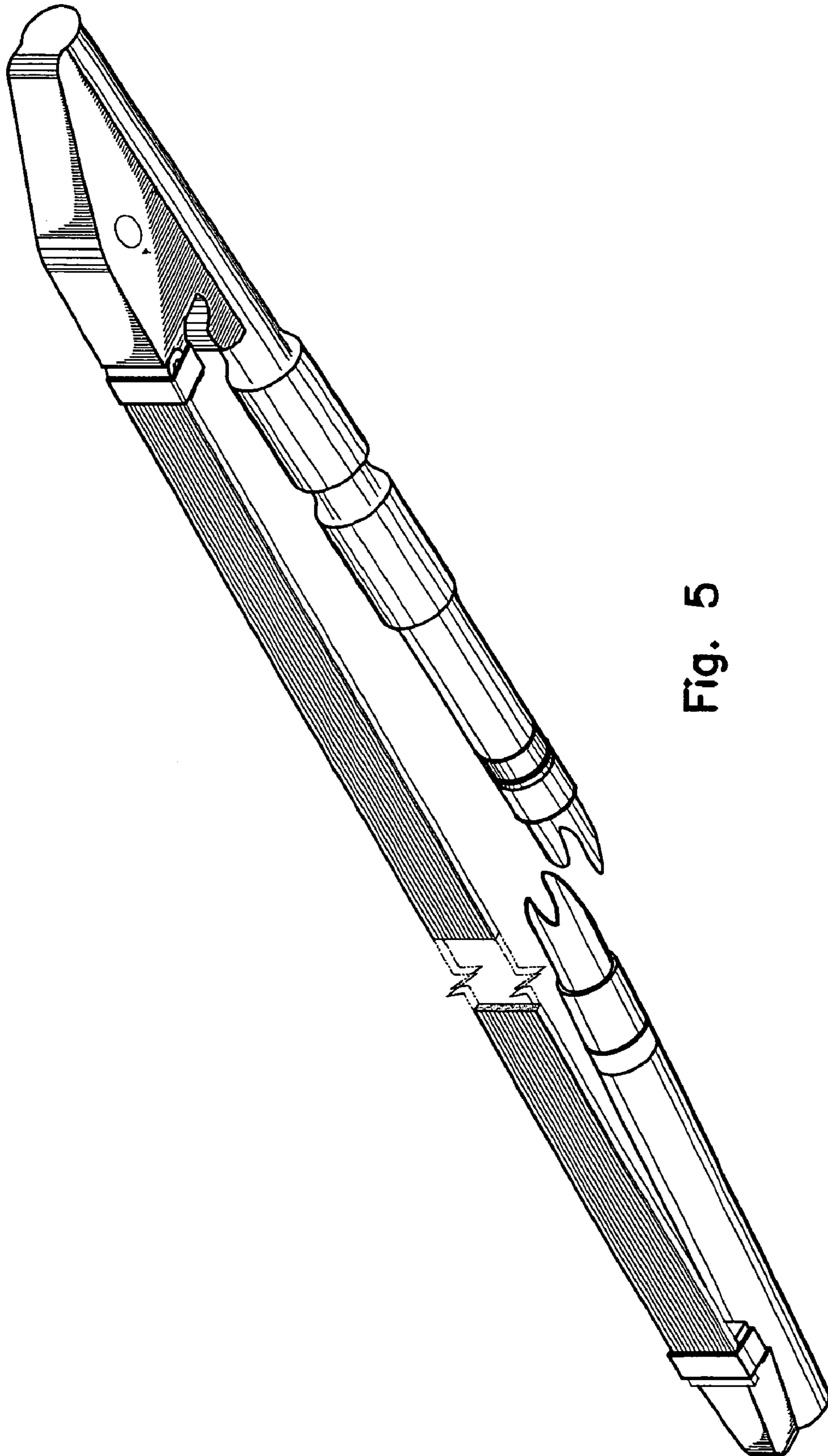

Fig. 5



Fig. 6

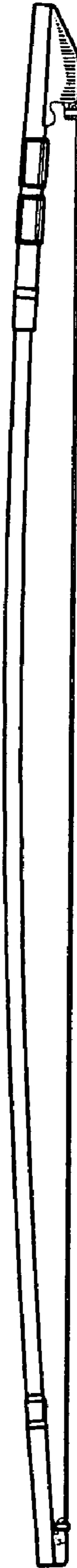

Fig. 7

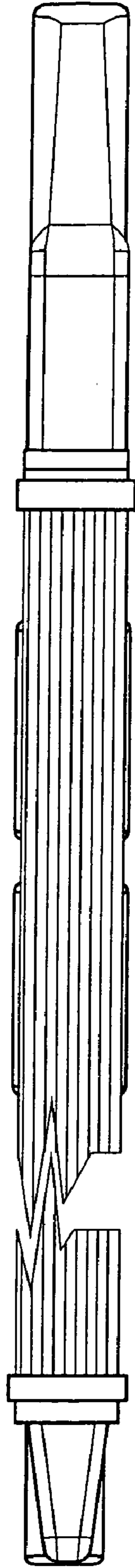

Fig. 8

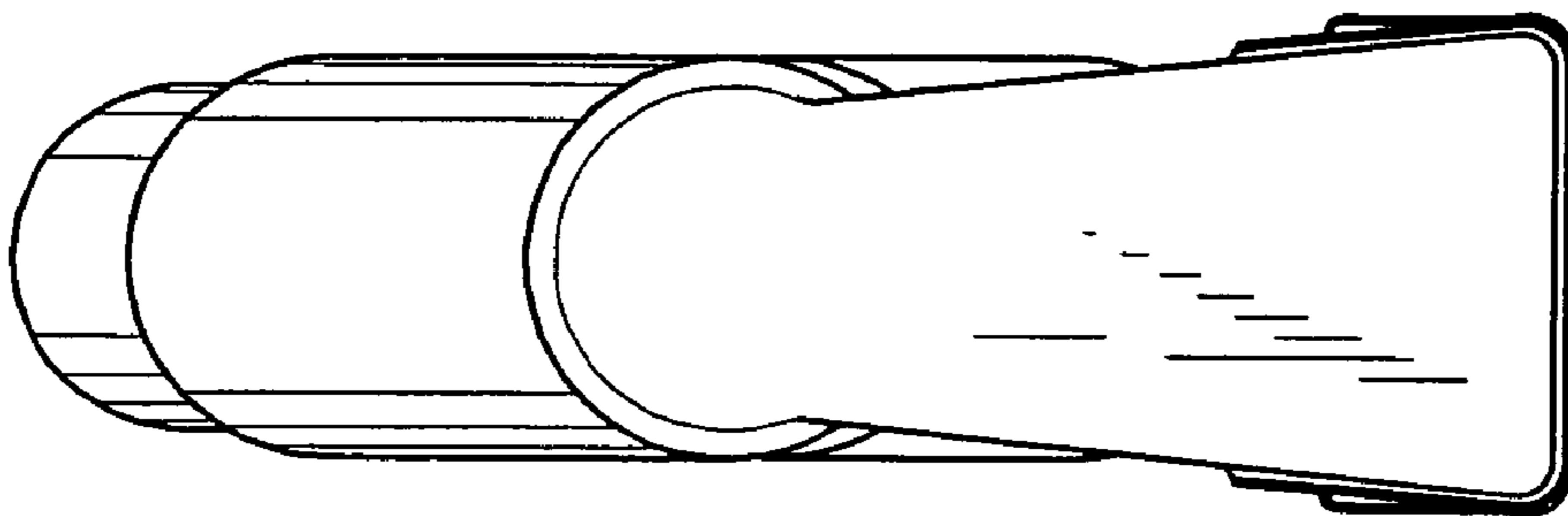

Fig. 9

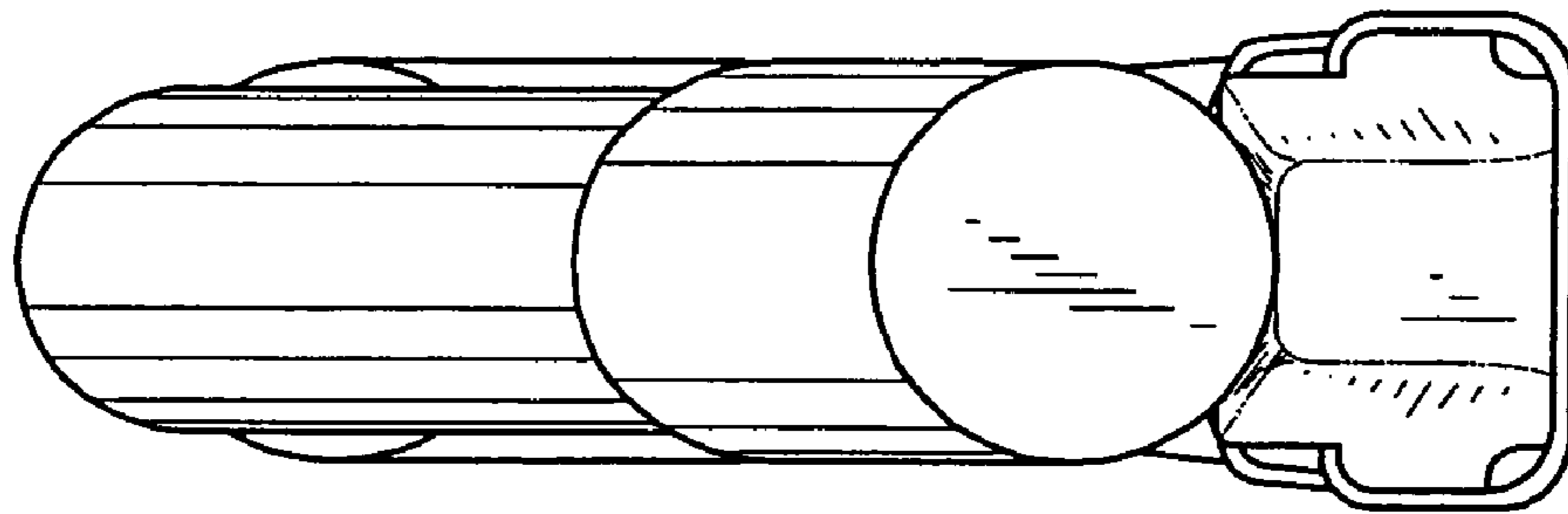

Fig. 10