



US00D552149S

(12) **United States Design Patent**  
**Sakai et al.**

(10) **Patent No.:** **US D552,149 S**  
(45) **Date of Patent:** **\*\* Oct. 2, 2007**

(54) **PROJECTOR**  
(75) Inventors: **Shigenori Sakai**, Tokyo (JP); **Susumu Ogawa**, Tokyo (JP); **Yasushi Itou**, Tokyo (JP); **Masayuki Ageishi**, Tokyo (JP); **Naoto Fukasawa**, Tokyo (JP)  
(73) Assignee: **NEC Display Solutions, Ltd.**, Tokyo (JP)  
(\*\*) Term: **14 Years**

JP	1010484	3/1998
JP	1072526	3/2000
JP	1072527	3/2000
JP	1081587	5/2000
JP	1201237	2/2004
JP	1220158	9/2004
JP	1239431	3/2005
JP	1239447	3/2005
JP	2005-014263	5/2005
JP	2005-014275	5/2005
JP	2005-015361	5/2005

(21) Appl. No.: **29/238,356**

\* cited by examiner

(22) Filed: **Sep. 14, 2005**

*Primary Examiner*—Adir Aronovich  
*Assistant Examiner*—Wan Laymon

(30) **Foreign Application Priority Data**

(74) *Attorney, Agent, or Firm*—Seyfarth Shaw LLP

May 18, 2005 (JP) ..... 2005-014274

(57) **CLAIM**

(51) **LOC (8) Cl.** ..... **16-02**  
(52) **U.S. Cl.** ..... **D16/230; D16/225**  
(58) **Field of Classification Search** ..... D16/205,  
D16/208, 213, 221, 225, 230, 231, 234, 235;  
D21/514; 353/115, 119, 122, 39; 352/34,  
352/242; 349/5, 7, 8, 9  
See application file for complete search history.

The ornamental design for a projector, as shown and described.

**DESCRIPTION**

(56) **References Cited**

FIG. 1 is a perspective view of a projector showing our new design.

**U.S. PATENT DOCUMENTS**

FIG. 2 is a front elevational view thereof;

D429,270 S \* 8/2000 Ishibashi et al. .... D16/231  
D442,983 S \* 5/2001 Goto et al. .... D16/230  
D449,331 S \* 10/2001 Kawahara et al. .... D16/230  
6,334,686 B1 \* 1/2002 Shiraishi et al. .... 353/119  
D473,253 S \* 4/2003 Shimamoto ..... D16/231  
D504,453 S \* 4/2005 Junsi et al. .... D16/231

FIG. 3 is a rear elevational view thereof;

**FOREIGN PATENT DOCUMENTS**

JP 1010459 3/1998

FIG. 4 is a left-side elevational view thereof;

FIG. 5 is a right-side elevational view thereof;

FIG. 6 is a top plan view thereof; and,

FIG. 7 is a bottom plan view thereof.

The broken lines in the FIG. 3 are for illustrative purposes only and form no part of the claimed design.

**1 Claim, 5 Drawing Sheets**

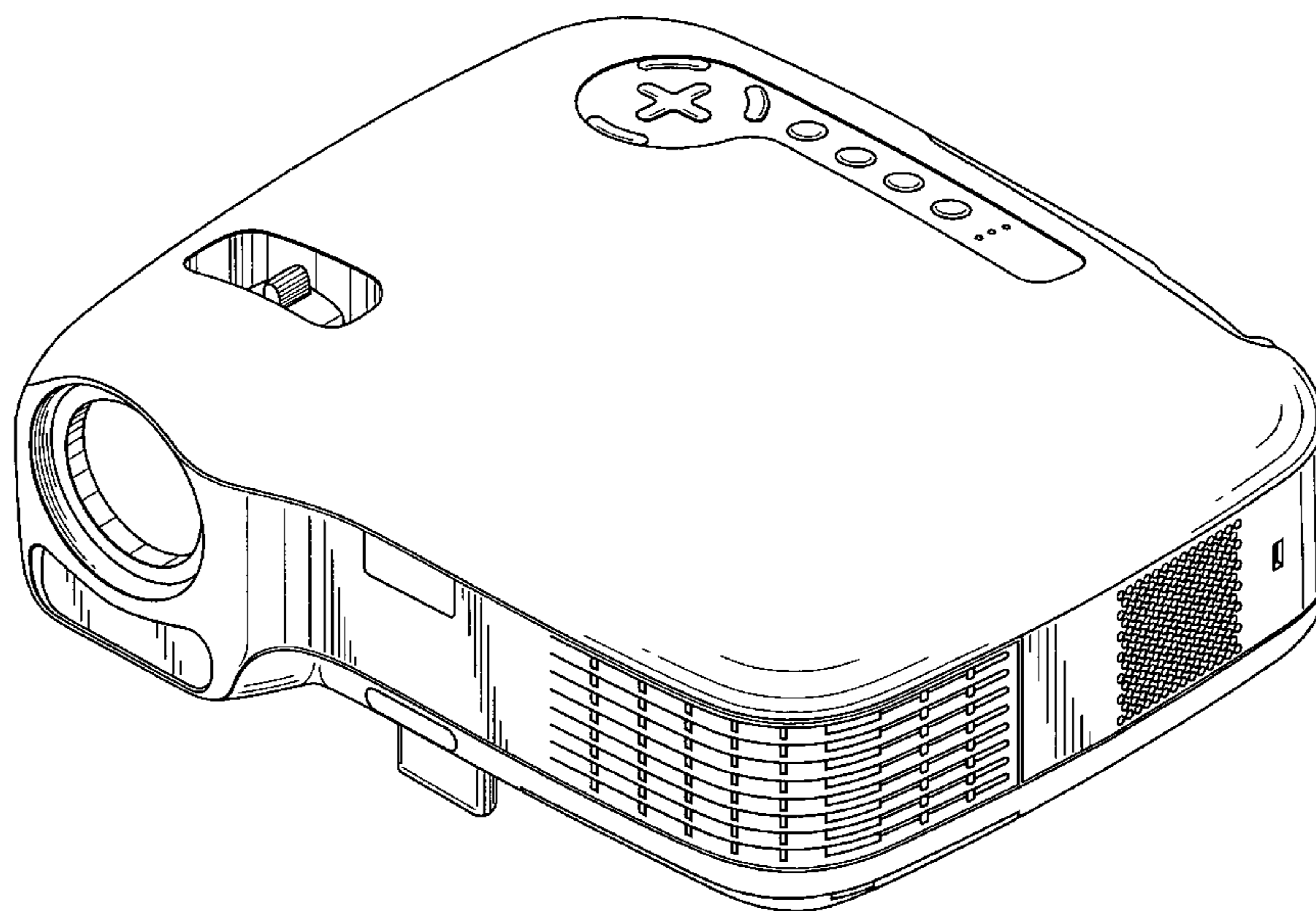

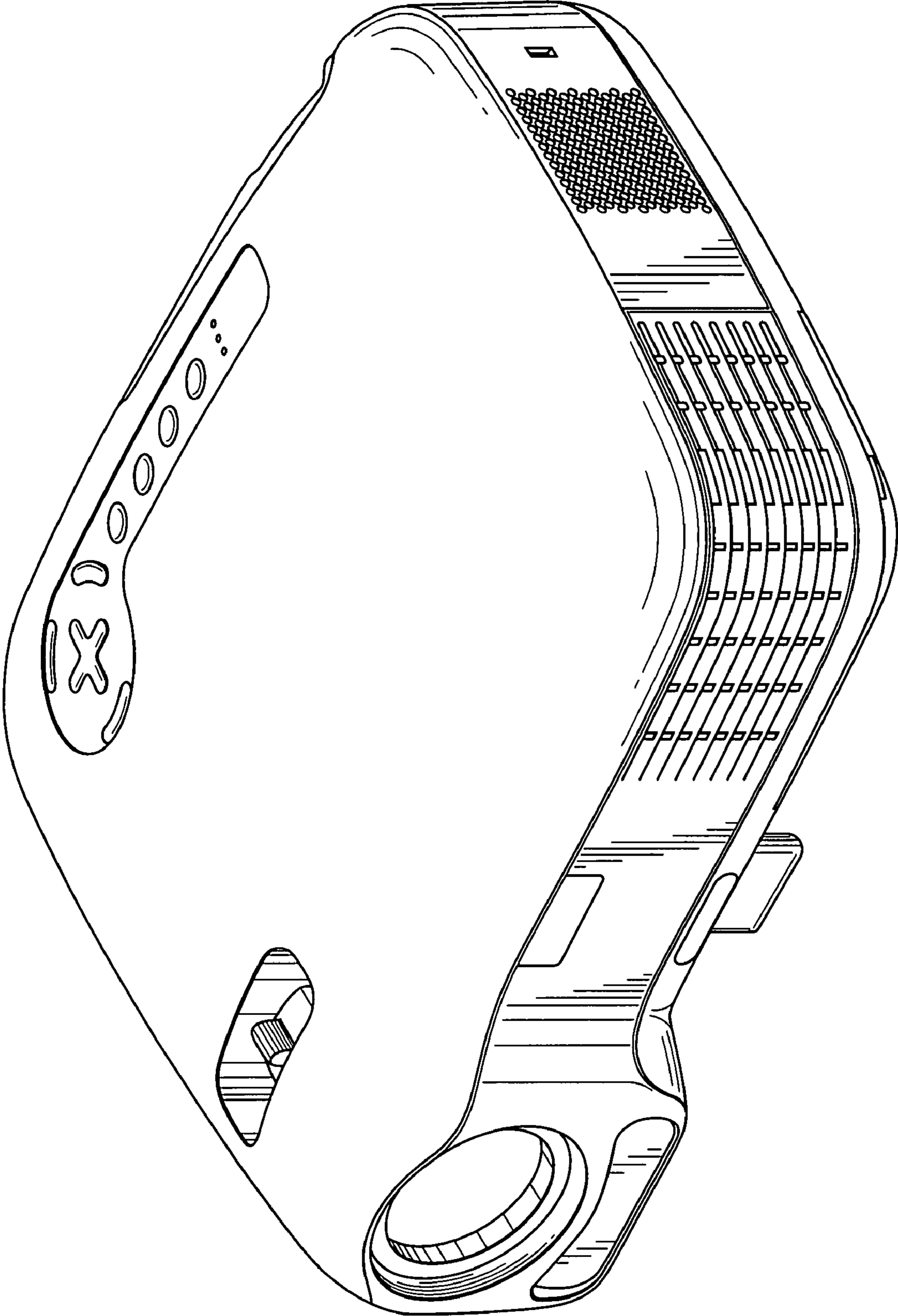

Fig. 1

Fig. 2

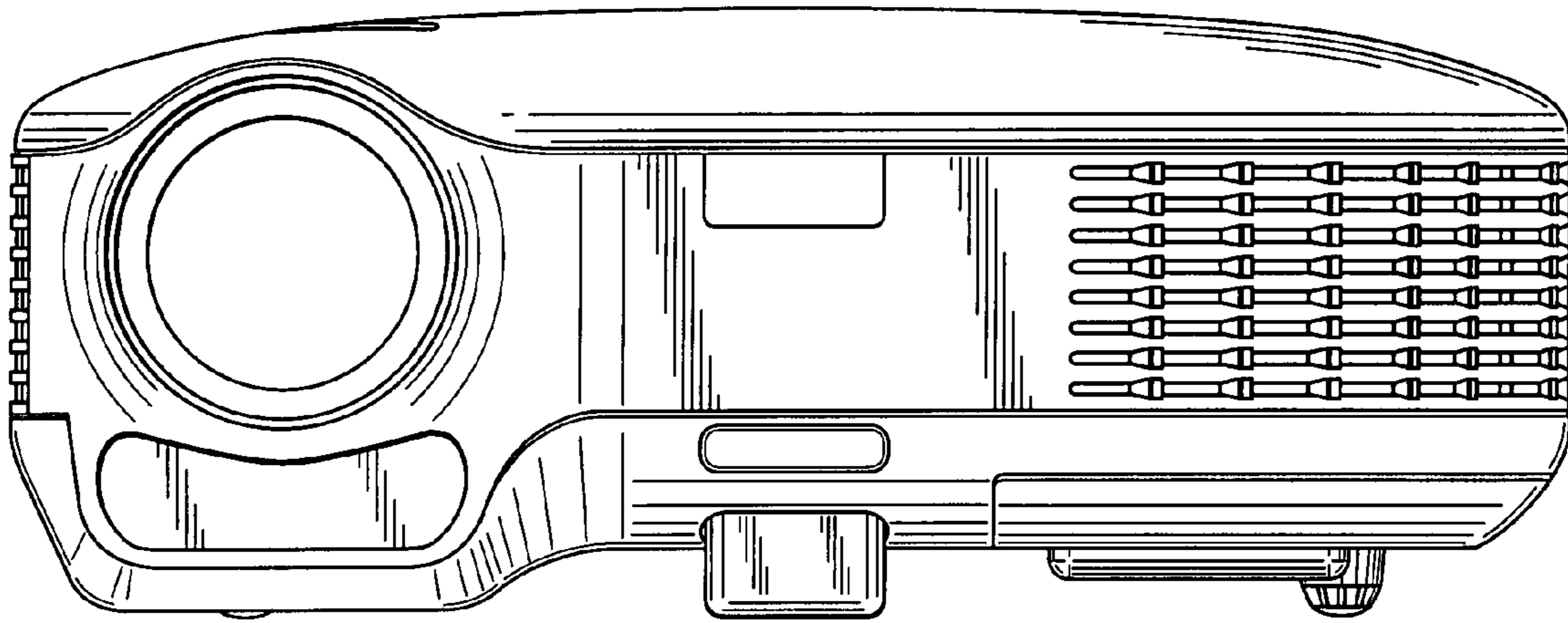
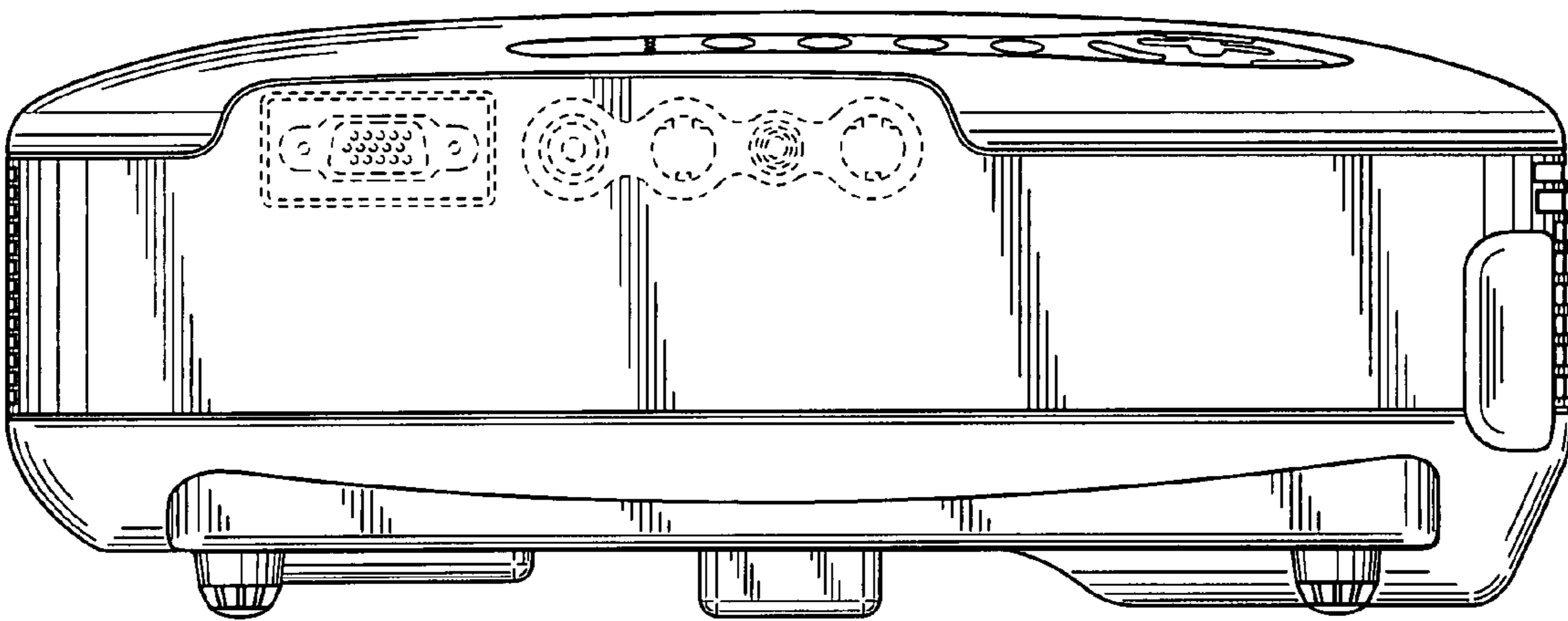
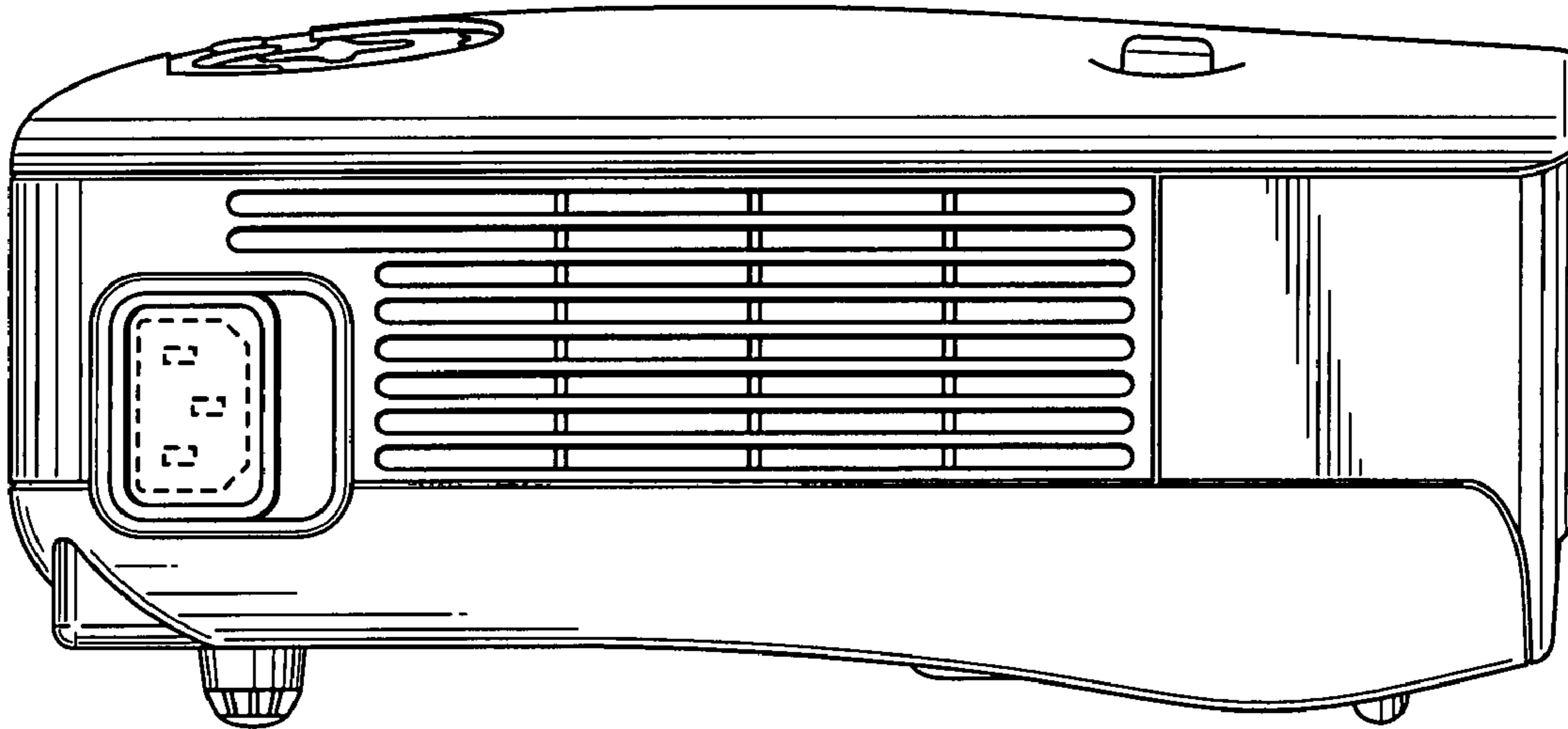

Fig. 3



**Fig. 4**



**Fig. 5**

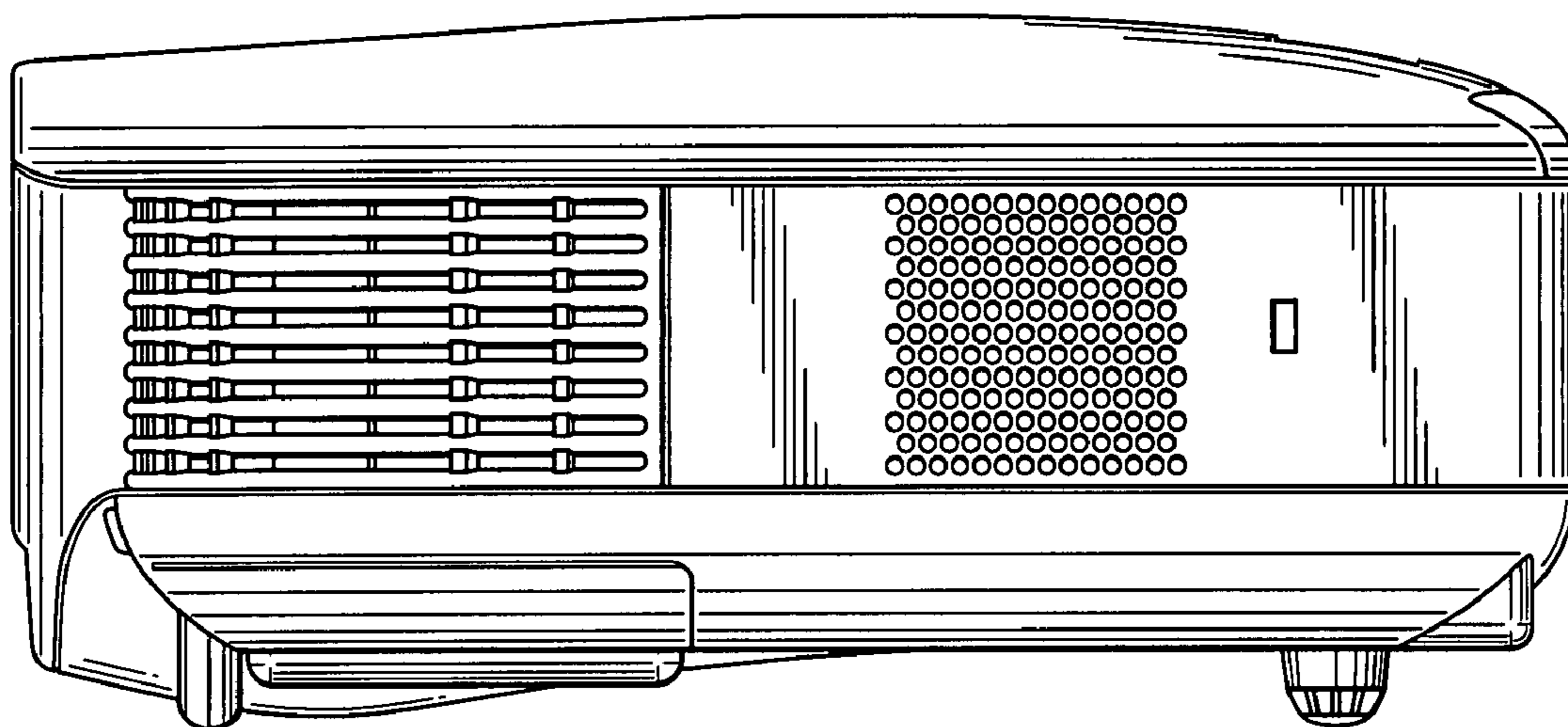

Fig. 6

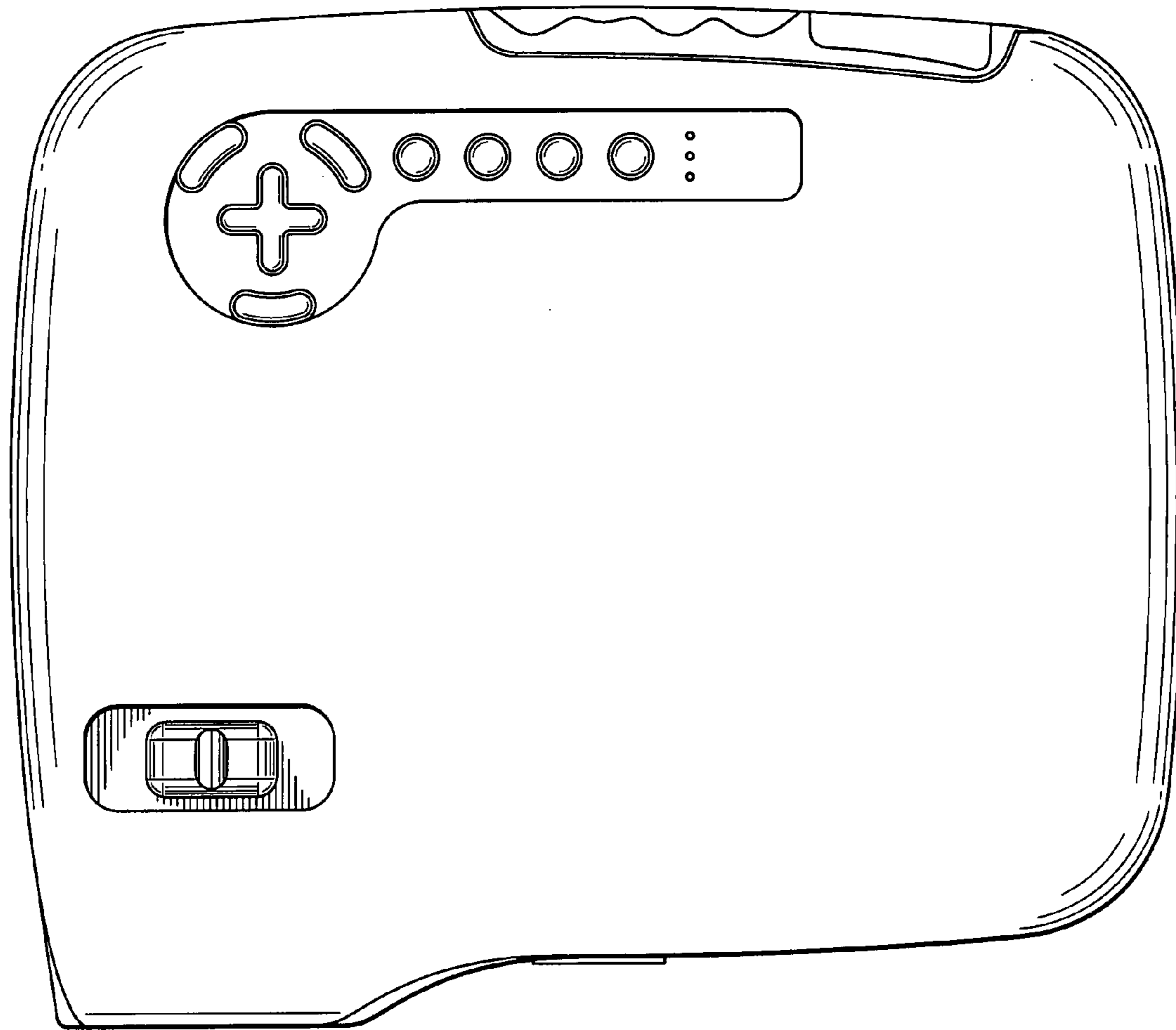

Fig. 7

