



US00D551960S

(12) **United States Design Patent**  
**Shinjo**

(10) **Patent No.:** **US D551,960 S**

(45) **Date of Patent:** **\*\* Oct. 2, 2007**

(54) **SELF-PIERCING NUT**

(75) **Inventor:** **Tadashi Shinjo**, Osaka (JP)

(73) **Assignee:** **Shinjo Manufacturing Co., Ltd.**,  
Osaka (JP)

(\*\*) **Term:** **14 Years**

(21) **Appl. No.:** **29/255,416**

(22) **Filed:** **Mar. 9, 2006**

(30) **Foreign Application Priority Data**

Sep. 15, 2005 (JP) ..... 2005-026692

(51) **LOC (8) Cl.** ..... **08-08**

(52) **U.S. Cl.** ..... **D8/397**

(58) **Field of Classification Search** ..... D8/382,  
D8/387, 397, 398, 399; 411/81, 88, 90-93,  
411/96-98, 103, 114, 106-108, 132-165,  
411/172-189, 197, 204, 248, 337, 338, 366.1,  
411/366.2, 366.3, 368-369, 371.2, 371.5,  
411/418, 427, 429-432, 436, 437, 526, 531-538,  
411/542, 544; 70/229; 301/35.623, 111.01  
See application file for complete search history.

(56) **References Cited**

**U.S. PATENT DOCUMENTS**

2,138,409	A *	11/1938	Salter	.....	411/183
2,486,769	A *	11/1949	Watson, Jr.	.....	411/180
3,314,138	A *	4/1967	Double	.....	29/432.2
3,736,969	A *	6/1973	Warn et al.	.....	411/179
4,690,599	A *	9/1987	Shinjo	.....	411/180
D364,178	S *	11/1995	Hansson et al.	.....	D15/139
D367,002	S *	2/1996	Grey	.....	D8/397

D450,236	S *	11/2001	Shinjo et al.	.....	D8/397
D451,375	S *	12/2001	Shinjo et al.	.....	D8/397
D451,376	S *	12/2001	Shinjo et al.	.....	D8/397
D451,791	S *	12/2001	Shinjo et al.	.....	D8/397
D452,140	S *	12/2001	Shinjo et al.	.....	D8/397
D487,281	S *	3/2004	Roman et al.	.....	D15/139
D522,025	S *	5/2006	Niebauer et al.	.....	D15/139
D523,039	S *	6/2006	Niebauer et al.	.....	D15/139
2005/0186046	A1 *	8/2005	Shinjo	.....	411/180

\* cited by examiner

*Primary Examiner*—T. Chase Nelson

*Assistant Examiner*—Karen Acker

(74) *Attorney, Agent, or Firm*—Antonelli, Terry, Stout & Kraus, LLP.

(57) **CLAIM**

The ornamental design for a self-piercing nut, as shown and described.

**DESCRIPTION**

FIG. 1 is a perspective view of the self-piercing nut;

FIG. 2 is a top plan view thereof;

FIG. 3 is a front elevation thereof, the rear elevation being identical;

FIG. 4 is a right-side elevation thereof, the left side elevation being identical;

FIG. 5 is a bottom plan view thereof;

FIG. 6 is a cross section taken along the line 6—6 in FIG. 2; and,

FIG. 7 is a cross section taken along the line 7—7 in FIG. 2.

**1 Claim, 2 Drawing Sheets**

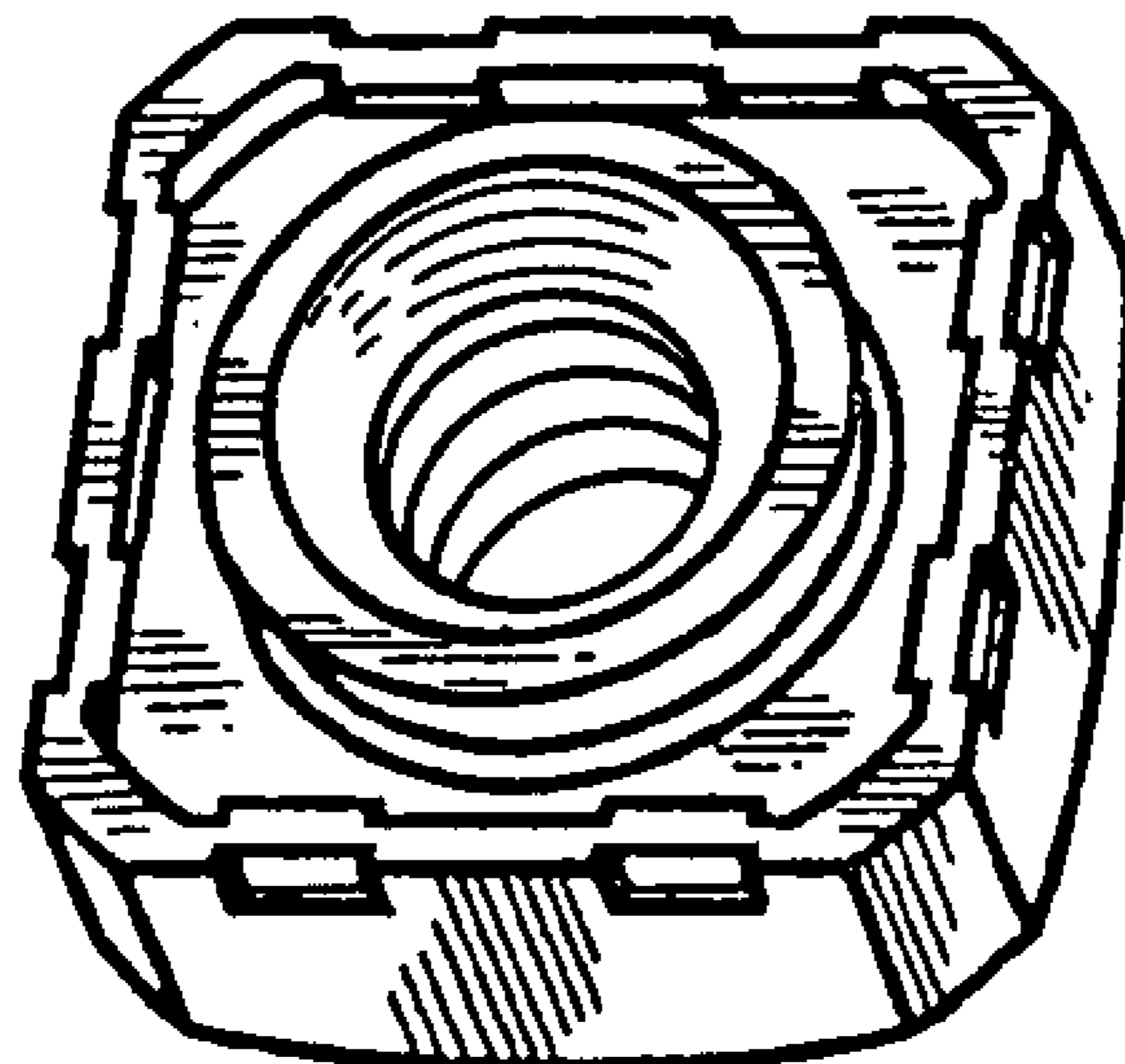

**Fig. 1**

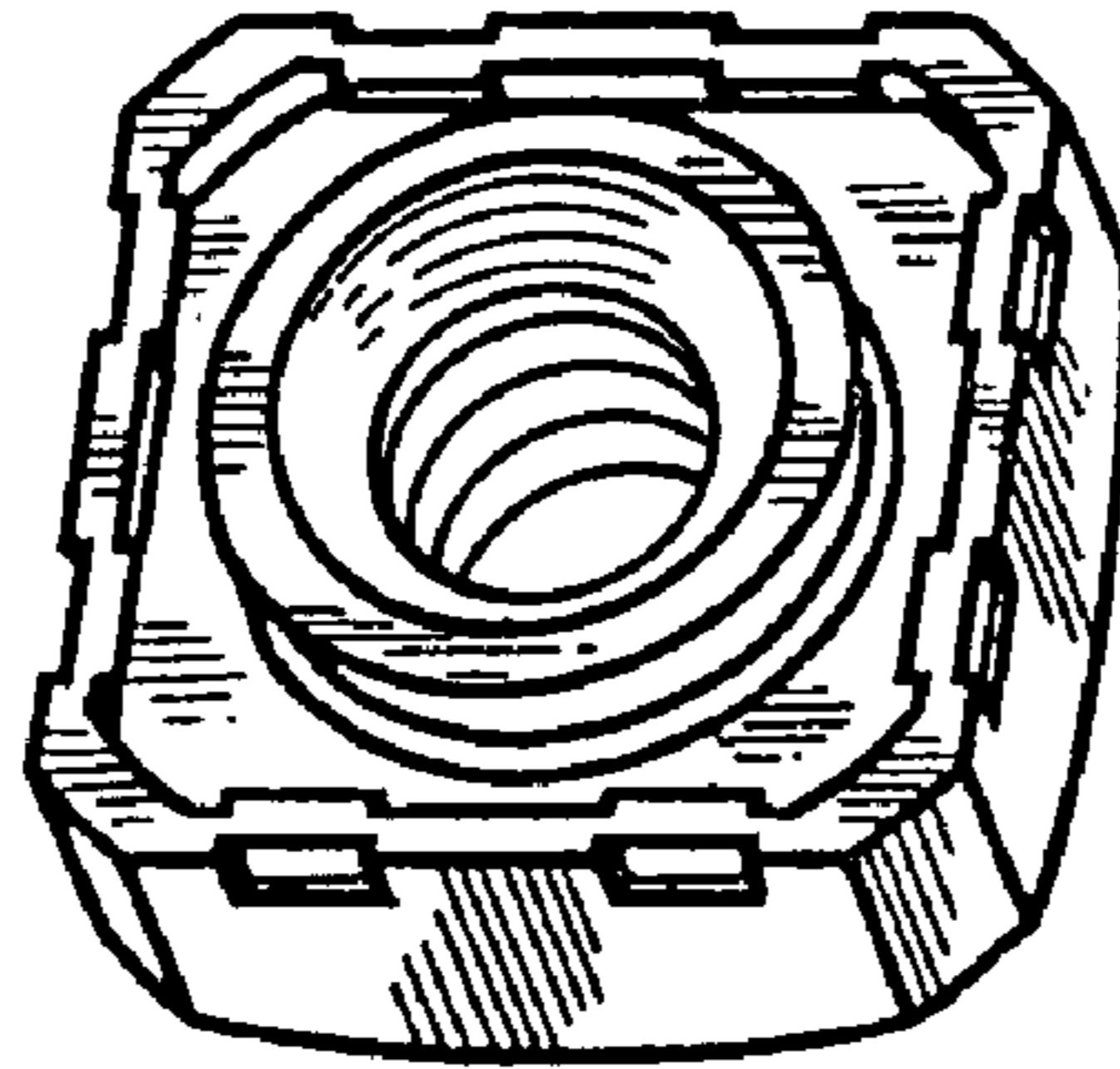

**Fig. 2**

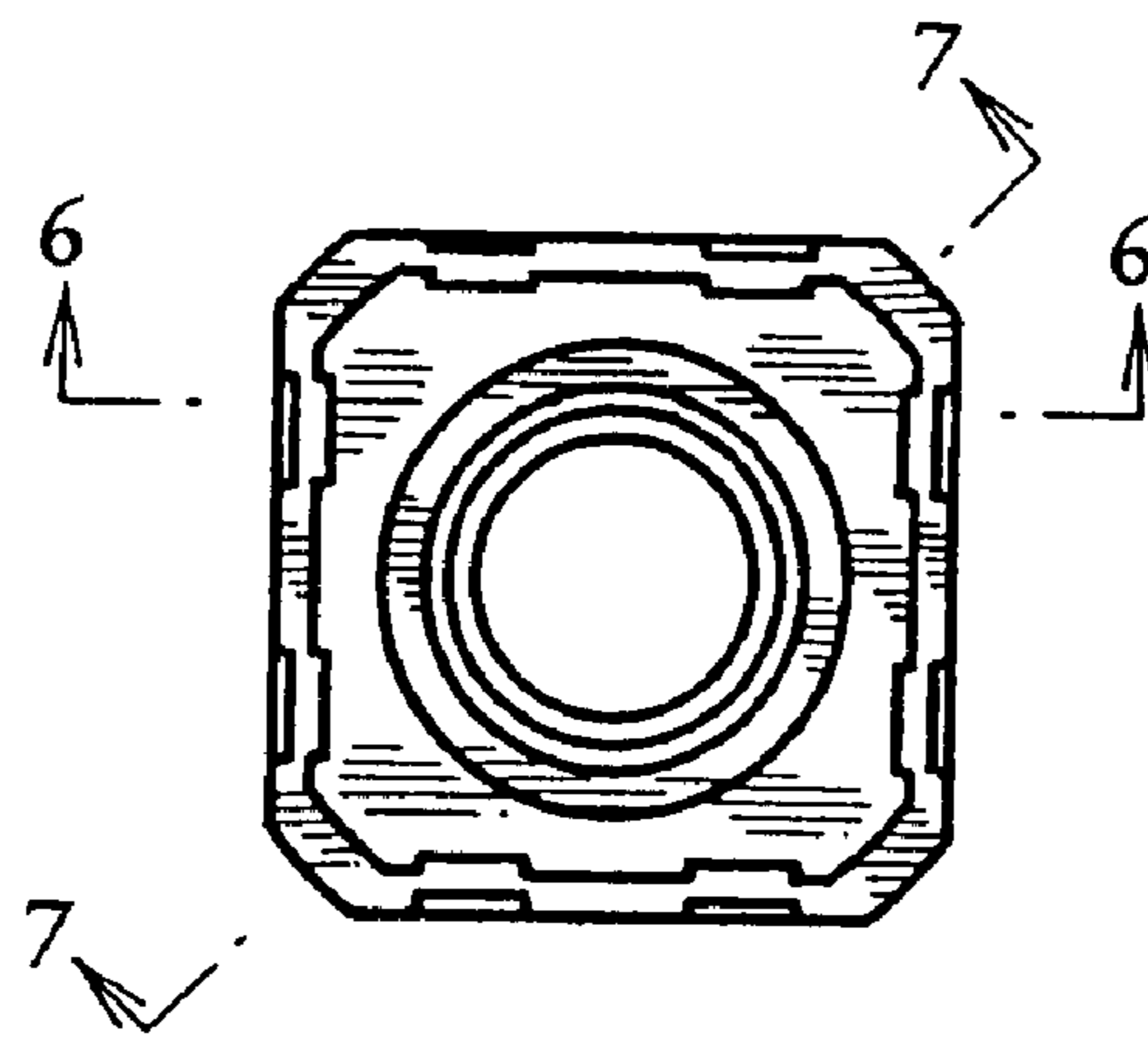

**Fig. 3**

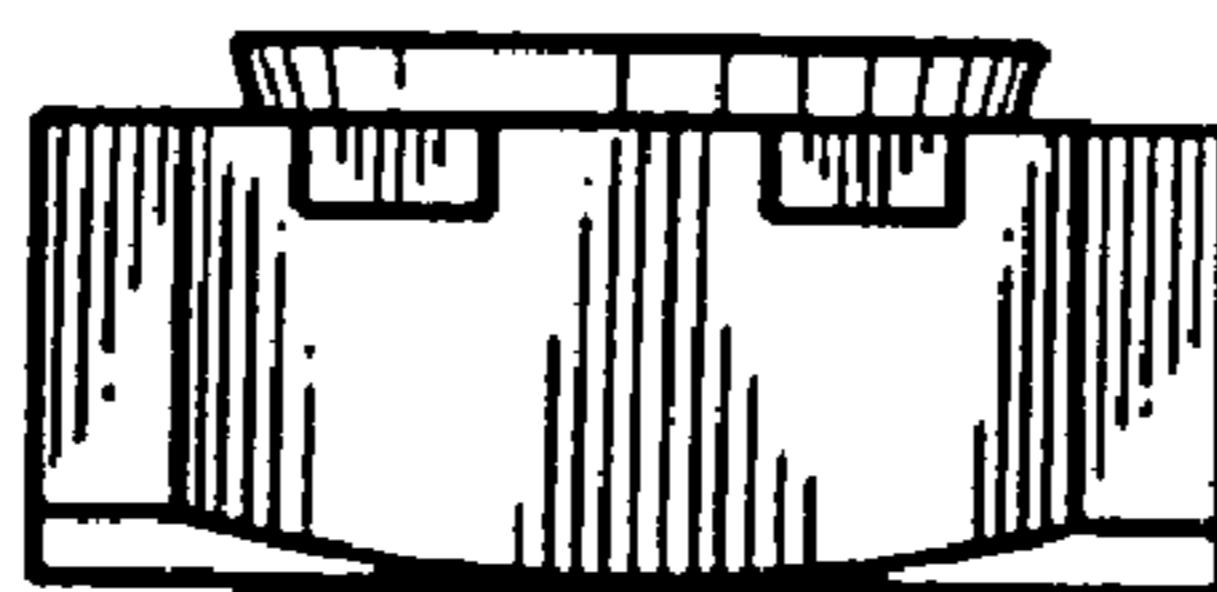

**Fig. 4**



**Fig. 5**

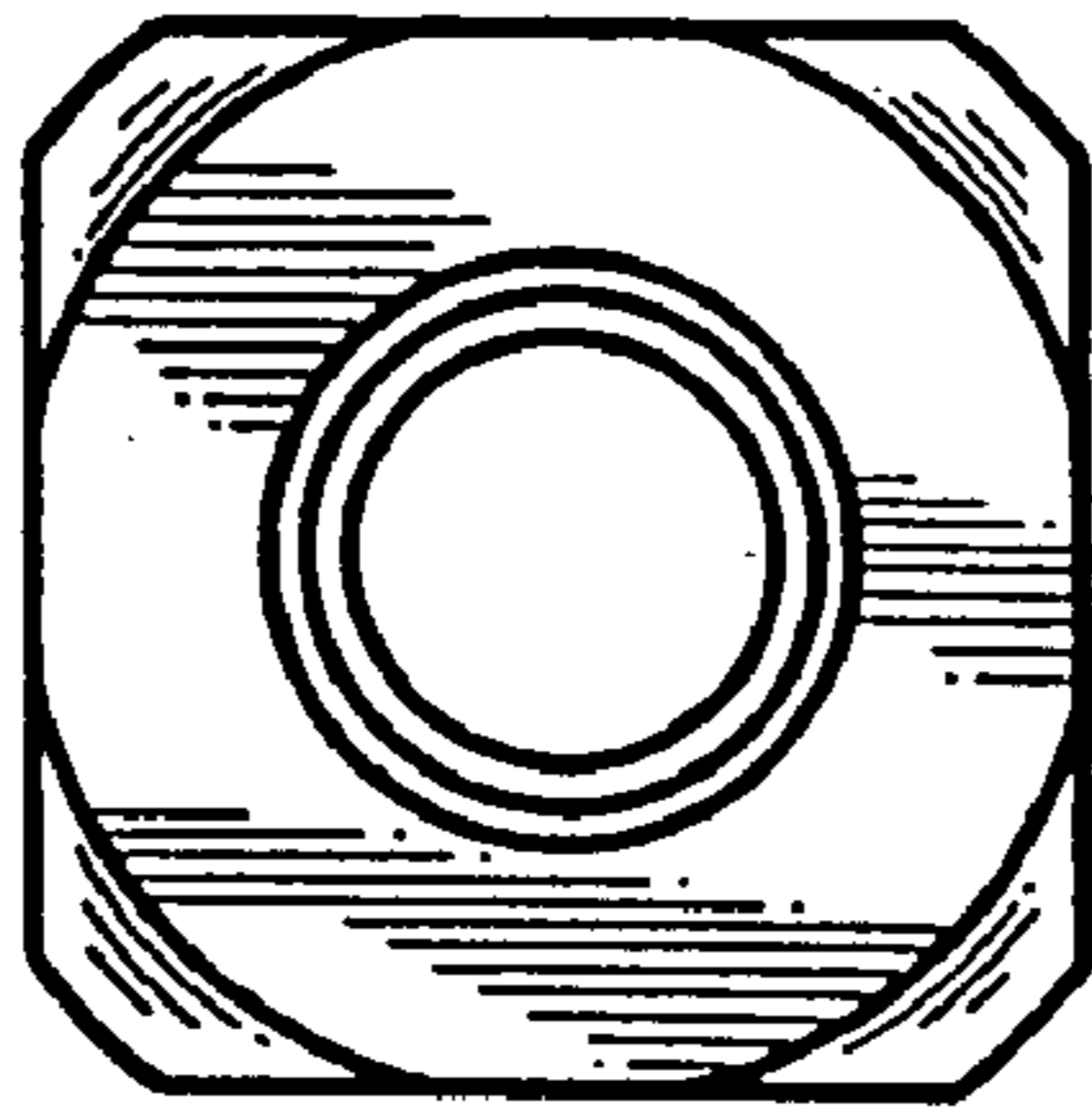

**Fig. 6**

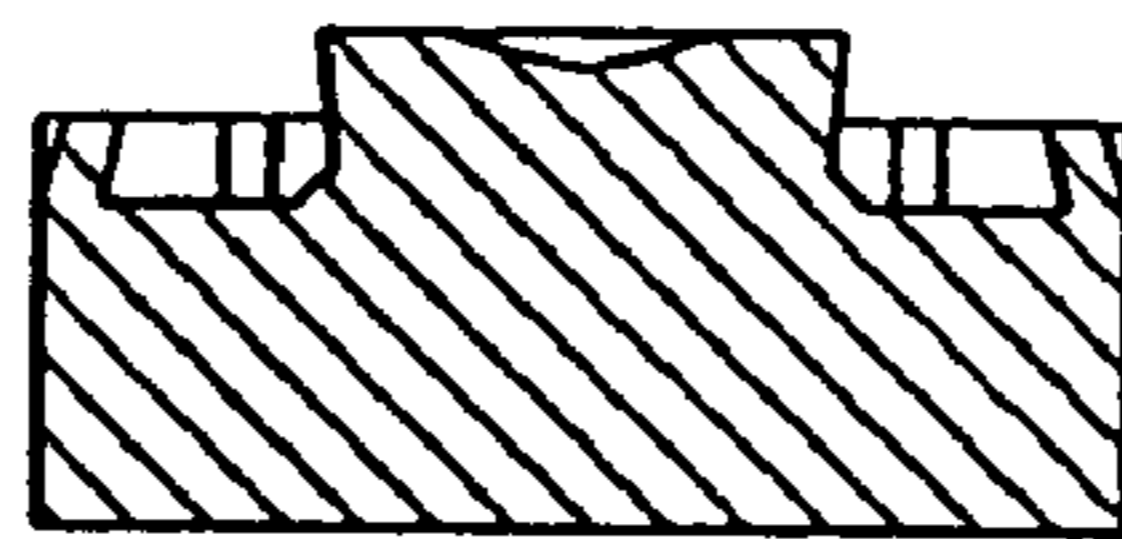

**Fig. 7**

